

I. SHONE & E. AULT.
EJECTOR FOR RAISING SEWAGE OR OTHER LIQUIDS.

(Application filed May 26, 1899.)

(No Model.)

7 Sheets—Sheet 1.

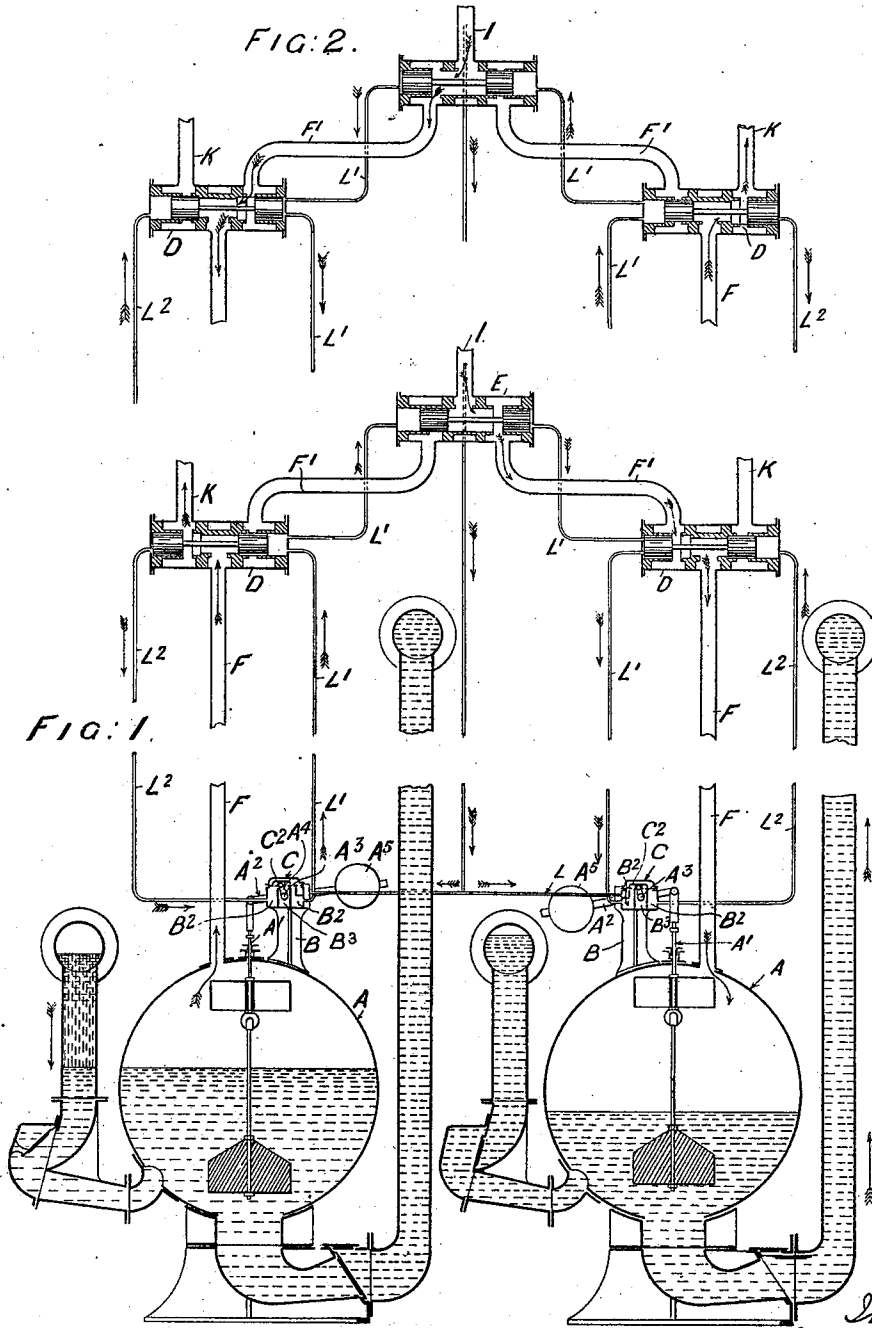

Witnesses
Edwin Ault
W. Sommers

Inventors,
 Isaac Shone
 Edwin Ault
 by *Henry M. [Signature]*

I. SHONE & E. AULT.
EJECTOR FOR RAISING SEWAGE OR OTHER LIQUIDS.

(Application filed May 26, 1899.)

(No Model.)

7 Sheets—Sheet 2.

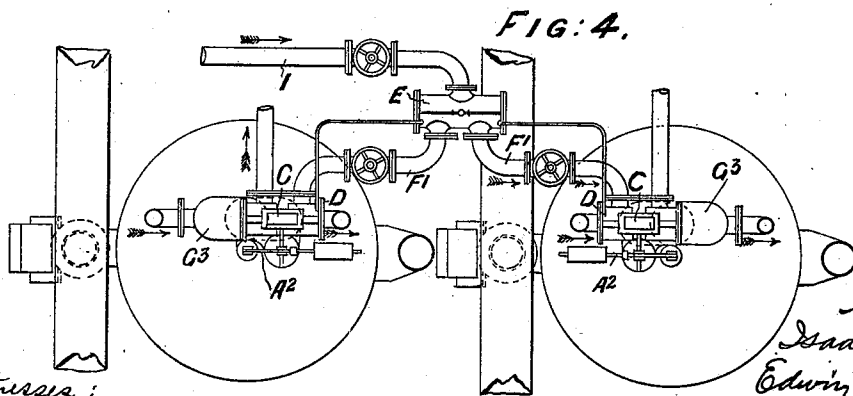
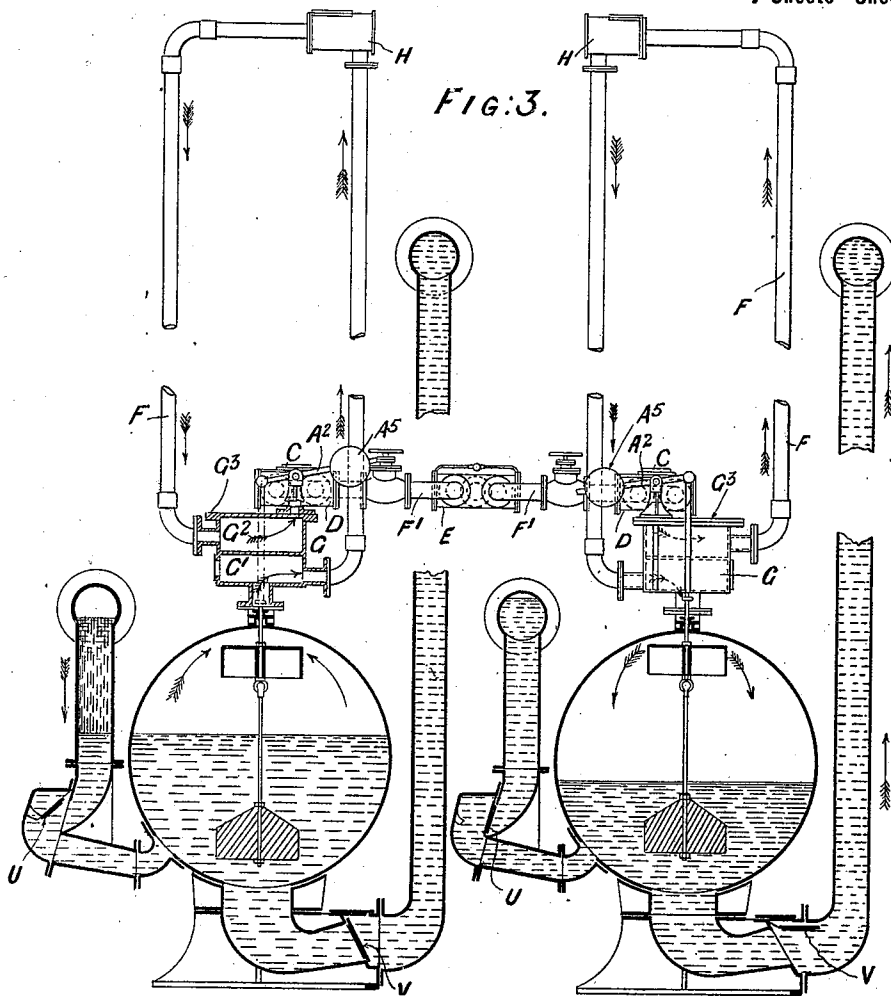

Witnesses:
Wm. B. Summers

Inventors
 Isaac Shone
 Edwin Ault.

by *Henry O. M. Dale*

I. SHONE & E. AULT.
EJECTOR FOR RAISING SEWAGE OR OTHER LIQUIDS.

(Application filed May 26, 1899.)

7 Sheets—Sheet 3.

(No Model.)

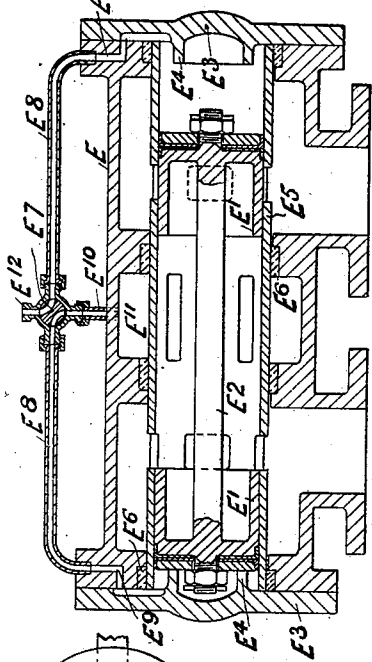

FIG. 9.

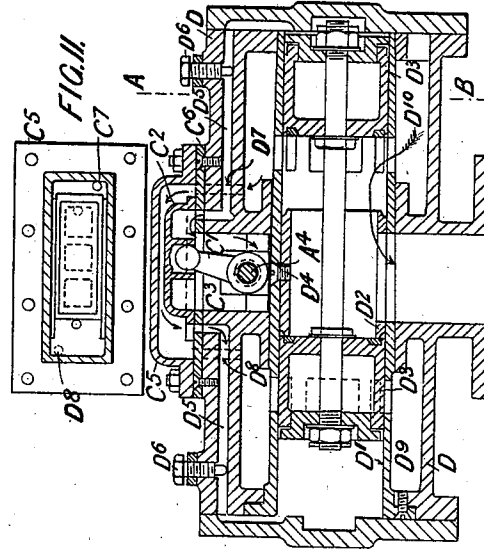

FIG. 10.

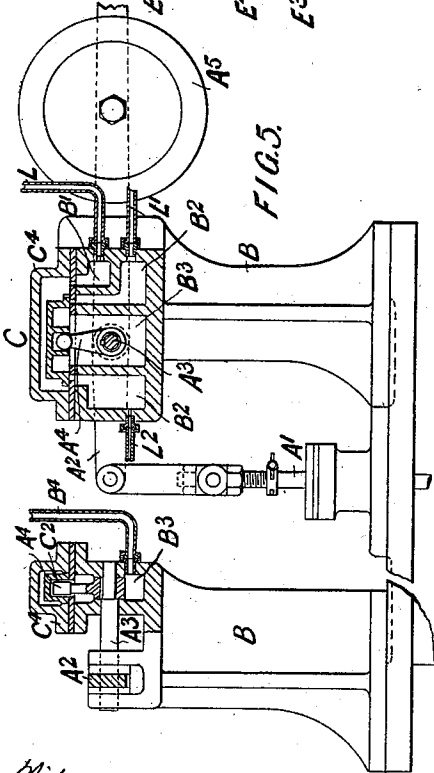

FIG. 5.

FIG. 6.

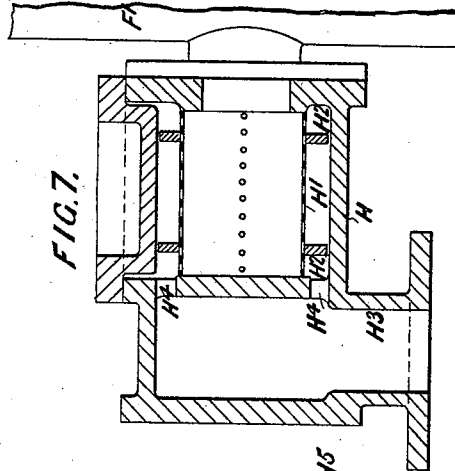
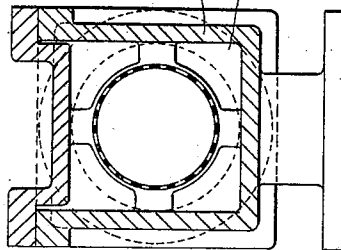

FIG. 7.

FIG. 8.



Witnesses
 Attest
 B. Sommers

Inventors
 Isaac Shone
 Edwin Ault.
 by *[Signature]*

I. SHONE & E. AULT.

EJECTOR FOR RAISING SEWAGE OR OTHER LIQUIDS.

(Application filed May 26, 1899.)

(No Model.)

7 Sheets—Sheet 4.

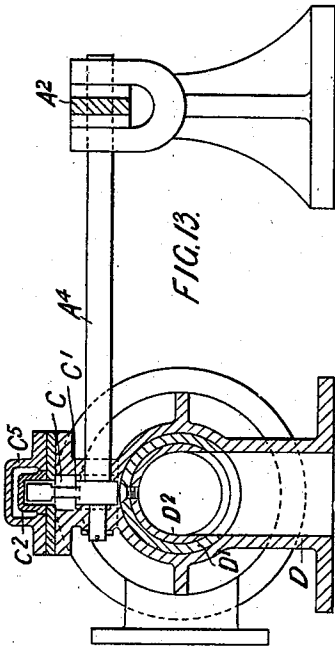

FIG. 13.

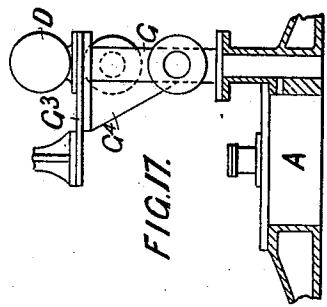

FIG. 17.

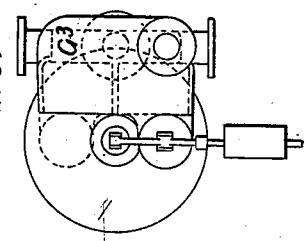

FIG. 16.

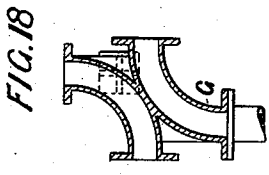

FIG. 18.

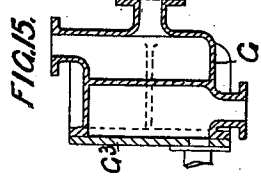

FIG. 15.

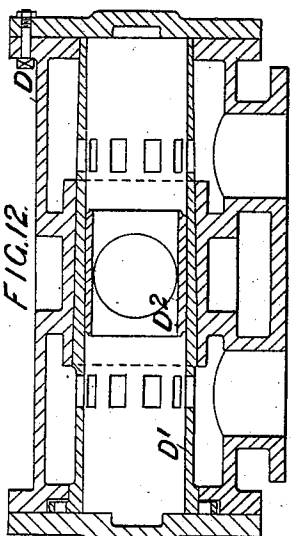

FIG. 12.

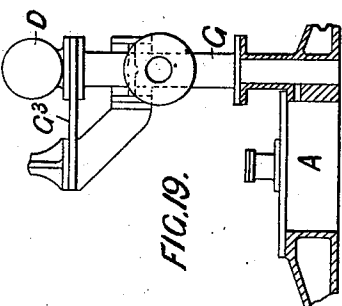

FIG. 19.

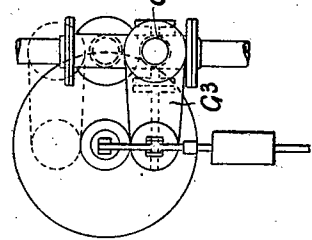

FIG. 20.

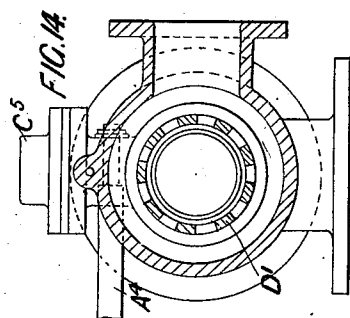

FIG. 14.

Witnesses
[Signature]
[Signature]
 W. Sommers

Inventors
 Isaac Shone
 Edwin Ault.

by
[Signature]
 Attorney

I. SHONE & E. AULT.

EJECTOR FOR RAISING SEWAGE OR OTHER LIQUIDS.

(Application filed May 26, 1899.)

(No Model.)

7 Sheets—Sheet 5.

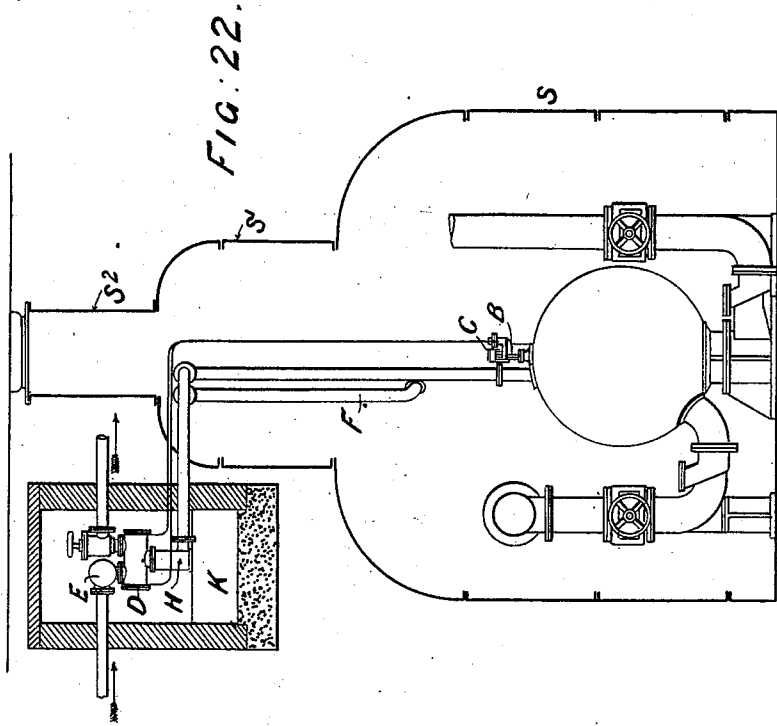

FIG. 22.

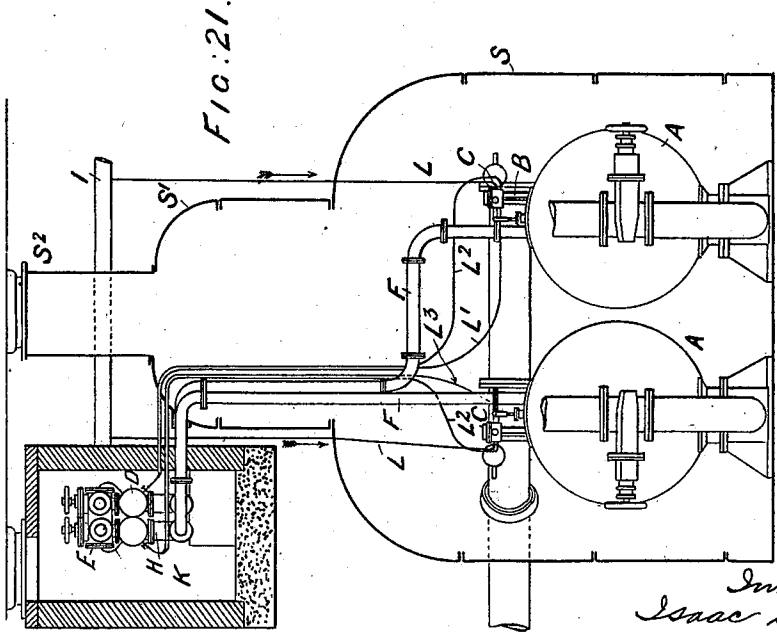

FIG. 21.

Witnesses.
 Attest
 W. Sommers

Inventors:
 Isaac Shone,
 Edwin Ault,
 by *Jerry M. [Signature]*

No. 664,183.

Patented Dec. 18, 1900.

I. SHONE & E. AULT.

EJECTOR FOR RAISING SEWAGE OR OTHER LIQUIDS.

(Application filed May 26, 1899.)

(No Model.)

7 Sheets—Sheet 6.

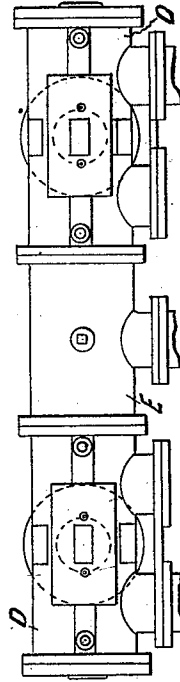
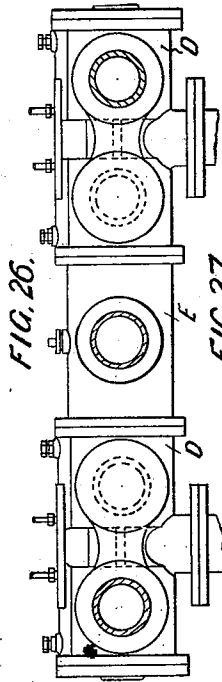
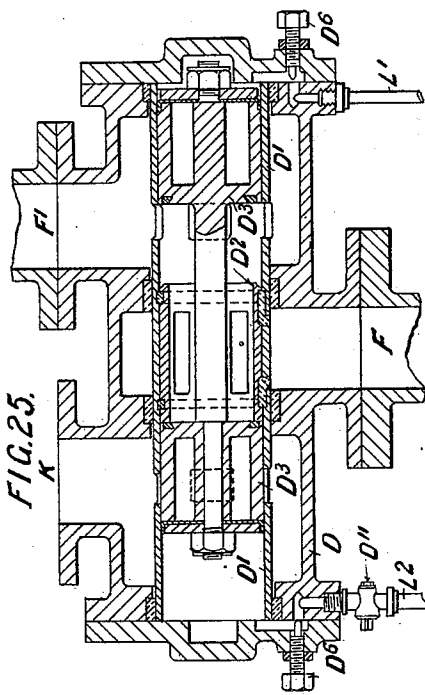

FIG. 23.

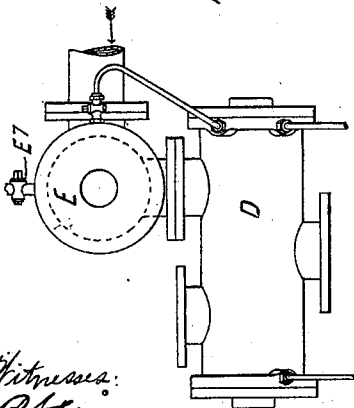
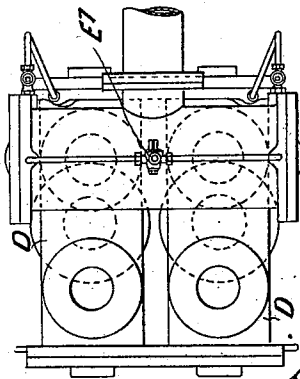

FIG. 24.



Witnesses:
C. P. ...
C. Sommers

Inventors:
 Isaac Shone
 Edwin Ault.
by [Signature]

No. 664,183.

Patented Dec. 18, 1900.

I. SHONE & E. AULT.

EJECTOR FOR RAISING SEWAGE OR OTHER LIQUIDS.

(Application filed May 26, 1899.)

(No Model.)

7 Sheets—Sheet 7.

FIG. 30.

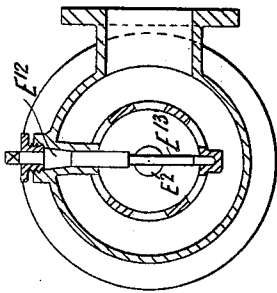

FIG. 31.

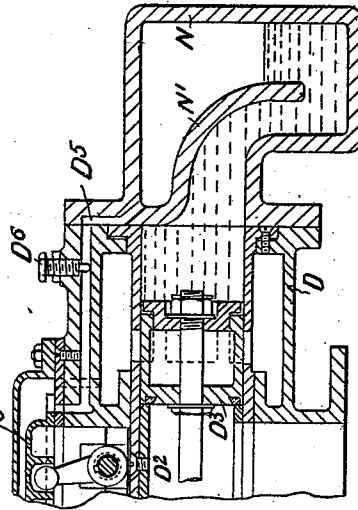

FIG. 28.

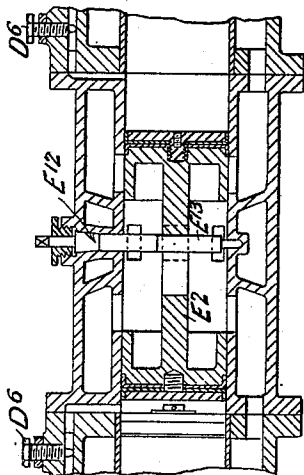
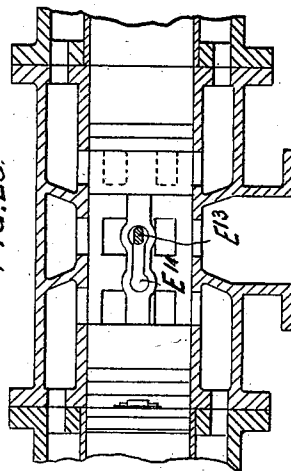

FIG. 29.



Witnesses:

H. H. ...
W. Sommers

Inventors

Isaac Shone
Edwin Ault

by J. W. ...

UNITED STATES PATENT OFFICE.

ISAAC SHONE AND EDWIN AULT, OF LONDON, ENGLAND.

EJECTOR FOR RAISING SEWAGE OR OTHER LIQUIDS.

SPECIFICATION forming part of Letters Patent No. 664,183, dated December 18, 1900.

Application filed May 26, 1899. Serial No. 718,387. (No model.)

To all whom it may concern:

Be it known that we, ISAAC SHONE and EDWIN AULT, subjects of the Queen of Great Britain and Ireland, and residents of 47 Victoria street, Westminster, London, England, have invented certain new and useful Improvements in and Relating to Ejectors for Raising Sewage or other Liquids, (for which we have applied for a patent in Great Britain, No. 23,305, dated November 5, 1898;) and we do hereby declare the following to be a full, clear, and exact description of the invention, such as will enable others skilled in the art to which it appertains to make and use the same, reference being had to the accompanying drawings, and to letters of reference marked thereon, which form a part of this specification.

The improvements in and relating to ejectors for raising sewage and other liquids have for their object to render their working more perfect and refer to our pneumatic system described in the specifications of our Patents No. 235,910, dated December 28, 1880, No. 485,714, dated November 8, 1892, and No. 417,100, dated December 10, 1889. Where it is required, for instance, in a low-lying district to raise ordinary town sewage to a higher level in order that it may acquire the necessary fall to run off into a river or into the sea or to outfall works, we in our pneumatic system employ a so-called "ejector" or usually a pair of ejectors, each comprising a sewage-receptacle whereinto the town sewage naturally gravitates, and a float therein operating automatically a valve device for admitting compressed air into the receptacle when the float has risen to a certain height. The compressed air then acting upon the surface of the sewage forces it up a pipe to the desired level, whence it can flow off into the river or into the sea. Certain other valves and pipes are also provided in this system for carrying it into effective operation.

Figure 1 is a diagrammatic view of an arrangement of two ejectors with the various valves, and Fig. 2 a similar view showing the valves in other positions. Fig. 3 is a part-sectional elevation of an arrangement of two ejectors with the various valves, and Fig. 4 is a plan view. Fig. 5 is a sectional elevation, and Fig. 6 a part-sectional end view, of

the slide-valve which is actuated by the float in the ejector. Fig. 7 is a sectional elevation, and Fig. 8 a sectional end view, of a strainer. Fig. 9 is a sectional elevation of a controlling-valve. Fig. 10 is a sectional elevation of a main or automatic valve with slide-valve. Fig. 11 is a sectional plan showing the slide-valve and the face whereon it works. Fig. 12 is a plan section of the main valve; Fig. 13, a sectional end view of same; and Fig. 14 a section on line A B, Fig. 10. Fig. 15 is a sectional elevation, Fig. 16 a plan view, and Fig. 17 an end elevation, of a standard or pedestal upon which the main valve is mounted. Fig. 18 is a sectional elevation, Fig. 19 an end elevation, and Fig. 20 a plan, of another form of standard. Fig. 21 is a sectional elevation, and Fig. 22 a sectional end elevation, of an ejector-station with two ejectors having their main valves and controlling-valve arranged together near the surface of the ground. Fig. 23 is an elevation, and Fig. 24 a plan, of a controlling-valve placed across two main valves. Fig. 25 is a sectional elevation of a main valve detached from the slide-valve and provided with a fixed liner. Fig. 26 is an elevation, and Fig. 27 a plan, of a controlling-valve fixed end for end between two main valves. Fig. 28 is a sectional elevation, Fig. 29 a plan section, and Fig. 30 a cross-section, of the controlling-valve shown in Figs. 26 and 27. Fig. 31 is a sectional elevation of a main valve with hollow cover containing liquid.

Hitherto in our aforesaid ejector system where two ejectors were acting in an installation, two being provided chiefly in order that one might be available while the other was being internally inspected or repaired, they worked independently of each other, although discharging into the same outlet-pipe, and usually both ejectors discharged together, which was economically a disadvantage, especially because the flow through the rising main was necessarily intermittent, which involved either that said main had to be of increased internal diameter than would be necessary for constant flow or that the friction of the sewage through such main became very high.

Now one important object of our present invention is to insure that the ejectors dis-

charge one at a time and when maximum flow of sewage occurs at regular alternate times, or nearly so. For this purpose we employ what we call an "automatic controlling-valve," and instead of, as heretofore, supplying compressed air direct to the main automatic valves of the two ejectors we supply the compressed air to the controlling-valve, which is preferably of the piston form and which we have found suitable for the main automatic valves. Suitable stop-valves are provided, so that one half of the system can be worked while the other is being repaired. The so-called "automatic main valve," by the float in the ejector acting on a slide-valve, is automatically opened for admitting compressed air onto the top of the sewage in the ejector when the latter has run full of sewage. This valve has hitherto been in direct or immediate communication with the ejector, and it has been our practice to place it some distance above the ejector, so as to prevent flooding of the main valve by sewage rising therein when the ejector was not at work; but this has the disadvantage of making the so-called "ejector-station," or the building wherein the ejector is erected, very lofty and, in consequence, expensive. Moreover, we have not found any check-valve efficient in preventing the sewage from rising into the automatic valve, while at the same time permitting the free flow of high-pressure air in and out of the ejector at a great velocity. The exhaust-air rushing from the ejector to the automatic main valve also at times carried along with it and deposited in the said valve, thereby impairing its efficiency, grit, chips, pieces of string, and other objectionable matters which had been carried up by the sewage and left clinging to the communicating pipe. In order, therefore, to overcome these difficulties or disadvantages, we so arrange the main valve that it is not in near or immediate communication with the ejector, and we employ in many cases a pipe leading from the ejector up some considerable distance and then down to the main valve and provide a strainer preferably in the highest part of the pipe and by preference made of a special form, so as to be accessible for cleaning. Figs. 1 and 2 show diagrammatically such an arrangement of parts. Upon the top of each ejector A, for convenience sake, but not communicating therewith, is placed a pedestal or standard B, which carries the box of a slide-valve C², which by the pipe L receives compressed air from the store of compressed air and by the pipes L' and L² supplies such air from one of the chambers B² in the pedestal to one end or the other of a main double piston-valve D, (the so-called "automatic" or "main" valve.) This valve is of the same general construction as before—that is to say, with two pistons connected by a rod—but by preference of an improved form, as shall be presently described with reference to Figs. 10 and 12. The slide-valve is operated

from the float in the ejector by the rod A¹, lever A², lever fulcrum-spindle A³, and lever A⁴ on said spindle. A⁵ is a counterweight on the lever A². The improved form of slide-valve device C on its standard or pedestal B is shown in the detail views, Figs. 5 and 6. The stuffing-box for the spindle A³ is here dispensed with and the spindle and its lever A⁴ placed in a chamber B³ below the valve, which chamber as the slide-valve C² is moved communicates with the exhaust sides of the ports. The chamber B³ may either open direct to the atmosphere or be connected with the main exhaust-pipe K, Figs. 1 and 2, so as to prevent dirt or grit from entering the valve when flooding should happen to occur. The improved arrangement at the same time gives better facility for examining and cleaning the interior of the valve device C, for which purpose it is only necessary to remove the cover C⁴. Each main valve D communicates by a pipe F' with what we call a "controlling-valve" E, which also by a small pipe L' communicates with one end of the main valve D, while the other end of the latter by the small pipe L² communicates with a chamber B² of the pedestal B, as stated. The controlling-valve E is also made with two pistons connected by a rod. This valve will be described presently with reference to Fig. 9. The effect or mode of action of this arrangement of parts is as follows: Assuming the left-hand ejector to be receiving sewage, its controlling-valve E being then in position to place the said injector in communication with the atmosphere through its pipe F, controlling-valve chamber, and exhaust-pipe K, and that the right-hand ejector is just making a discharge, it has admitted compressed air by the action of its slide-valve device C through the pipe L² to one end of its main piston-valve D, and thereby driven it into the position shown in Fig. 1, which figure shows the controlling-valve E and the main valves D in such positions as to allow compressed air to flow from high-pressure pipe I through the controlling-valve-casing pipe F', main-valve casing, and pipe F to the right-hand ejector, as indicated by the arrows in Fig. 1. When the left-hand ejector is filled, compressed air is admitted through the pipe L² to its main valve D by the action of its slide-valve. This causes the piston of its valve D to move to the position shown in Fig. 2, and if the right-hand ejector has by this time completed its discharge the piston of its main valve D will also be moved by the action of its slide-valve C², Figs. 5 and 6, over to the position shown in Fig. 2. By these actions compressed air is admitted through the pipe L' and its extension L' of the right-hand ejector to one end of the controlling-valve E, and the other end is put in communication with the atmosphere through the pipe L' to the slide-valve of the left-hand ejector, so that the controlling-valve is by the compressed air moved into the position shown in Fig. 2, thereby opening the supply of com-

pressed air to the left-hand ejector and shutting the supply off to the right-hand ejector and placing the pipe F of the latter in communication with the atmosphere through its main-valve casing and pipe K. The arrows in the two figures show the direction of flow of the compressed and exhaust air in the two cases. It will be evident that the movement of the controlling-valve E is dependent upon the action of the main valves D of the two ejectors and that the controlling-valve will not be moved in one direction or the other until both the main valves have been moved into correct positions. If both ejectors are filling, the right-hand main valve D will be in the position shown in Fig. 2 and the left-hand main valve in the position shown in Fig. 1—that is to say, both ejectors will be in communication with the atmosphere through F, D, and K—in which case compressed air will be admitted to both ends of the controlling-valve, placing its divided piston in equilibrium. When one ejector is filled, the equilibrium of the controlling-valve is at once destroyed by compressed air being admitted to the opposite end of one of the main valves and one of the pipes L' being brought into communication with the atmosphere through the slide-valve. The controlling-valve is thereby moved over to the proper position to allow compressed air to flow to the full ejector through one of the pipes F. Assuming this ejector to be the right-hand one, the position of the valves will be as in Fig. 1, and if it should be the left-hand ejector the valves will be as in Fig. 2. Should one ejector become full before the other has completed its discharge, the right-hand main valve will be as shown in Fig. 1 and the left-hand main valve will be as shown in Fig. 2, in which case both ends of the controlling-valve will be open to the atmosphere through the pipes L' L' and will therefore be again in equilibrium until the one ejector has completed its discharge, when the controlling-valve piston is at once moved over by compressed air being admitted from the main valve through one of the pipes L' to one end of the controlling-valve and the compressed air allowed to flow through one of the pipes F to the ejector that is waiting for it.

Figs. 3 and 4 show an actual approved form of apparatus where, as often convenient, the slide-valves, the main valves, and the controlling-valve are arranged close together and just over the ejector, so that it becomes possible to make the ejector-station a low and inexpensive building, through the roof of which are passed the pipes F for conveying compressed air to and from the ejectors, thus preventing the access of sewage to any of the valves, which, as shown, are not in immediate communication with the ejectors. The pipes F at one lower end communicate with the ejector through a lower chamber G' in the hollow pedestal G and at the other lower end with a chamber G².

H is a strainer of improved form interposed

in the piping. It is shown in the detail views Figs. 7 and 8 and consists of a box with an internal perforated or wire-gauze cylinder H', which is kept in position by means of two rings H², brazed or otherwise secured around the cylinder H'. The exhaust-air entering from the ejector-pipe F by the opening H³ flows in through the openings H⁴ and H⁵, so that the objectionable matter is deposited on the outside of the perforated straining-cylinder H'.

The controlling-valve E in one suitable form is shown in the sectional elevation Fig. 9. It is made with a piston-valve in two parts E' E', united by a rod E². The end covers E³ are provided with rims E⁴, which limit the travel of the piston-valve. The latter may work in a liner E⁵, that is fixed in place by a suitable alloy run into recesses E⁶, such alloy being of the kind that melts at a comparatively low heat and expands in cooling—such, for instance, as the so-called "Spence's" metal.

In order to be able to put one ejector out of action for inspection or repair while the other ejector continues to work, we provide a four-way cock E⁷, with pipes E⁸, to each end of the valve-casting, which pipes by passages E⁹ communicate with the outer ends of the piston-valve. The branch E¹⁰ of the four-way cock E⁷ communicates with the compressed-air space E¹¹ and by the branch E¹² with the atmosphere. By closing taps provided on the pipes L' L', Fig. 1, and then turning the four-way cock E⁷, so that compressed air is admitted to drive the piston-valve E' to one end or other of its stroke, the flow of compressed air will be diverted to the main valve D that is to remain at work, while the other main valve and its ejector are cut off.

The controlling-valve E is in Figs. 3 and 4 shown between the two main valves D and connected therewith by means of pipes F' F', provided with stop-valves, which latter serve to shut off one or other half of the ejector system in case of repairs being needed for the same. Each main valve is also in this example shown fitted with its slide-valve C². This arrangement is illustrated by the detail views, Figs. 10, 11, 12, 13, and 14. The valve-body D is so constructed that it can be bored out in one operation and fitted with a liner D', which is ground in or shrunk in or fixed by a suitable alloy run into recesses, as described with reference to the liner of the controlling-valve, Fig. 9. The seating D², against the end of which the pistons D³ rest, may be secured in the liner D' by being shrunk in and secured by screws D⁴ or by means of suitable metal alloy run into recesses, as will also be described with reference to the liner in Fig. 25.

For the purpose of preventing or lessening the noise and shock now obtaining in the large sewage inlet and outlet valves V and U, Fig. 3, we prefer, but do not claim, to retard

the speed of travel of the main-valve pistons D^3 by reducing to an adjustable extent the transverse area in some part of the passages—for instance, the passages D^5 —by means of set-screws D^6 . The piston is thus caused to move as slowly as desired, so that the first fraction of compressed air is admitted more slowly to the ejector, being wiredrawn, and also the fall in pressure during the first fraction of the exhaust is less sudden, being also wiredrawn, so that the said sewage inlet and outlet valves are allowed to close gradually and noiselessly.

In order to adapt the same main valve D either for right or left hand position and application, we make the face on which the slide-valve C^2 slides in the form of a liner-plate C^6 , having an opening C^7 so arranged that when the plate C^6 is turned end for end the opening C^7 may either correspond with the port D^7 or the port D^8 , and thus admit compressed air to the space wherein the slide-valve slides either from the right or left hand of the main-valve body, so that either of the ports and connecting-passage D^9 D^{10} may be adapted for the compressed-air supply as required by turning the plate C^6 around. Thus any main valve taken from stock can be made either right-handed or left-handed, as required. Similarly, in order to adapt the pedestal or standard G , Figs. 3 and 4, upon which the main valve D in this arrangement is mounted, for either a right or left hand application we make it, as shown in Figs. 3 and 4 and in the detailed views, Figs. 15, 16, and 17, trough-shaped, with a flat reversible cover G^3 , supported on brackets G^4 , cast with the standard G . As will be understood from Figs. 3, 4, 16, and 17, the main valve D is fixed on the top of this standard, or we make the standard G , as shown in Figs. 18, 19, and 20, of a tubular four-way shape, with a reversible bracket-cover G^3 , upon which the main valve D is mounted.

Figs. 21 and 22 show an ejector-station with two ejectors having their slide-valve devices C mounted on the standards B on the ejectors, as in Fig. 1; but the controlling-valve E and both the main valves D are fixed in a chamber K at the surface of the ground. Such an arrangement is suitable in some cases; but it will be understood that in this case also the principle is carried out that there is no immediate or near communication between the ejectors and the valves and for the purpose that the sewage shall not enter the valves. The controlling-valve E is in this example placed across the two main valves D , as shown in the detail views, Figs. 23 and 24. The ejectors A are connected to the main valves D by means of pipes F F , led by any convenient route from each ejector to its corresponding main valve. The compressed-air supply to the slide-valve devices C C may be brought thereto through small pipes L L direct from the air-supply main I or in any other way. From the slide-valves the air for

actuating the main-valve pistons is carried through small pipes L' L^2 to the corresponding main valves. The standards B , upon which the slide-valve devices C are mounted, are as described with reference to Figs. 1, 5, and 6. The pipe L conveys compressed air to the chamber B' and thence through the port to the slide-valve chamber. The chambers B^2 B^2 and the small pipes L' L^2 take the place or are an extension of the passages D^5 of the main valve shown in Fig. 10 and are connected to the separated main valve, as shown in Figs. 1 and 2. The strainers H are here shown directly under the main valves; but they may be placed at any suitable part of the pipes F . The ejector-station is shown of a convenient form—that is to say, a comparatively shallow lower part S , a smaller intermediate part S' for the pipes to pass up through, and an upper manhole part S^2 .

In Fig. 25 is shown a main valve detached from its slide-valve. The liner D' is in this example fixed by means of a suitable alloy run into recesses, as previously explained, and the seating D^2 for limiting the piston travel is in a similar manner fixed in the liner D' . The throttling of the passages is in this example effected by passing the screws D^6 through the end covers or by means of a cock D^{11} on the pipe L^2 ; but we prefer to make the controlling-valve without a seating, like D^2 of the main valve, just referred to, which seating serves for making joint and for limiting the piston travel.

Where the controlling-valve and the two main valves are placed end for end, as may be found convenient, as shown in Figs. 26 and 27, we provide different means for limiting the piston travel, as will be understood from reference to Figs. 28 and 29, which are sectional elevation and sectional plan of the controlling-valve. Moreover, we use the means for limiting the piston travel also as a means for locking the piston at one end or the other when it so happens that one of the ejectors or parts belonging thereto have to be put out of action for inspection or repairs. For this purpose we provide a key E^{12} with a flat part E^{13} , on which the correspondingly-formed slot in the intermediate rod-shaped part E^2 can normally slide. This slot is widened out circularly at each end at E^{14} , and when the piston is driven to one end or the other it can be held there, as desired, for stopping the action by giving the key a quarter of a turn when the flat part E^2 comes into a cross position in the part E^{14} . When the main valves D D are arranged as shown in Figs. 26 and 27, the liners of the said valves must be easily removable or of the form shown, for instance, in Fig. 12.

As already stated, the slide-valves when separated from the main valves, as shown in Figs. 21 and 22, are supplied with compressed air from the main I , and consequently have abundance of air for actuating the main valves; but when the controlling-valve E is

connected with main valves having, as in Fig. 10, the slide-valve mounted on the main valve and when the slide-valves are not supplied with compressed air direct from the main it is necessary always to have a supply of compressed air at hand to operate the main-valve pistons, and for this purpose we admit a small quantity of compressed air to the pipes F' F', Fig. 1, either through a by-pass connected with the air-main I, and which may be partially throttled by a set-screw or a valve or cock or be provided with a reducing-valve, or such air may be admitted past the inside edges of the controlling-valve pistons, which for the purpose should not fit quite tight. There will thus always be sufficient compressed air in the main-valve passages to actuate these valves.

In order to keep the cup-leathers of the main-valve pistons supple and tight, especially in case the compressed air is hot and dry, we in some cases interpose a body of oil, glycerin, or other suitable liquid between the main-piston valve and the compressed air. One way of doing this is shown in Fig. 31, where the end cover is formed with a box N, provided with a partition N'. The compressed air is admitted by the passage D⁵; but instead of acting direct on the piston D³ it presses on the surface of the liquid, forcing the latter against the piston, and thus operating it.

What we claim as our invention, and desire to secure by Letters Patent, is—

1. In combination with two pneumatic ejectors provided each with a sewage-inlet pipe and valve and sewage-outlet pipe and valve and with a float which is connected with a slide-valve for operating it, said slide-valve communicating with the store of compressed air, a main double valve provided with a small pipe from each end leading to the slide-valve for being impelled thereby in one direction or the other and provided with an outlet-pipe for compressed air to the ejector, and outlet for the spent or exhaust air from the ejector and an inlet for compressed air: a controlling double valve communicating with the said inlet for compressed air to each main valve and having a pipe for receiving supply of compressed air from the store of compressed air and communicating at each of its ends with the said small pipes leading from the inner ends of the main valves to the slide-valves, for the purpose of being impelled thereby, the consequence of such arrangement being that the movement of the controlling-valve depends on the action and position of the two main valves, so that if one ejector has run full of sewage and its slide-valve by the action of its float in the ejector thereupon has admitted impelling compressed air to the main valve and moved the same to admit a charge of compressed air from the controlling-valve to the ejector for forcing out the sewage, the main valve for the other

ejector will not receive a charge of compressed air from the controlling-valve until it has run full of sewage and the one ejector has completed its discharge and the slide-valve of the other ejector in consequence has sent impelling compressed air by way of its main valve to the controlling-valve and moved the latter into the proper position for admitting a charge of compressed air through the said main valve to the said ejector substantially as set forth and for the purpose of insuring that only one of a pair of ejectors shall discharge at any time.

2. In apparatus such as described, the combination with two ejectors and appliances for each admitting compressed air to and exhausting the same from said ejectors, said appliances controlled by level variations in said ejectors; of mechanism controlling said appliances to admit compressed air to one of the ejectors and to simultaneously place the other in communication with the atmosphere, and to place both ejectors in communication with the atmosphere until the liquid in one has risen to a certain level, for the purposes set forth.

3. In apparatus such as described, the combination with two ejectors, a compressed-air-operated main valve for each ejector controlling the admission of compressed air thereto and its exhaust therefrom, and a valve for each of said ejectors controlled by level variations therein and controlling the supply of operative fluid to said main valves; of means controlling the operation of both main valves to admit compressed air to one ejector and exhaust the air from the other and to position said main valves to place both ejectors in communication with the atmosphere until the liquid in one has risen to a certain level, for the purposes set forth.

4. The combination with two pneumatic ejectors, connections therewith and with a source of compressed-air supply, a pneumatically-operated main valve in each of said connections, pressure-fluid-supply pipes for said valves, and valves in said supply-pipes, controlled by variations of the level of liquid in the ejectors; of a pneumatically-operated valve controlling both main valves to admit pressure fluid to the ejectors alternately and to place both ejectors in communication with the atmosphere when the level of the liquid therein is below a predetermined level, for the purposes set forth.

5. The combination with two pneumatic ejectors, connections therewith and with a source of compressed-air supply, a pneumatically-operated main valve in each of said connections, pressure-fluid-supply pipes for said valves, and valves in said supply-pipes controlled by variations of the level of the liquid in the ejectors; of a controlling-valve for both main valves operated by pressure fluid from said main valves to admit pressure fluid from the source of supply to the ejectors alternately, and to place both ejectors in commu-

nication with the atmosphere when the level of the liquid in the ejectors is below a predetermined level, for the purpose set forth.

6. The combination with two pneumatic
5 ejectors of the character described, and a main
and a slide valve for each of them: of a controlling valve device consisting of a divided piston-valve adapted to be reciprocated by means of compressed air in a cylindrical casting or valve-body having a central inlet opening toward the compressed-air store, an outlet opening toward each main valve, said opening being situated between the center and the
10 ends, and a small opening at each end with a small pipe communicating with the one end of each main valve and therethrough with a port of their respective slide-valves, substantially as and for the purposes set forth.

7. The combination with two pneumatic
20 ejectors of the character described, a main and a slide valve for each of them, a controlling valve device consisting of a divided piston-valve adapted to be reciprocated by means of compressed air in a cylindrical casting or
25 body having a central inlet opening toward the compressed-air store, an outlet opening toward each main valve, said openings situated between the center and the ends, a small opening at each end communicating with the one end of each main valve and therethrough with a port of their respective valves; of a rotatable key formed with a flat portion adapted to work in a slot in the rod which unites the two pistons of the aforesaid divided piston-valve, said slot having at each end a wider
30 part wherein the key when turned crosswise holds the said piston-valve fast at one or the other end of its stroke, whereby one of the ejectors can be examined or repaired while the other continues to work, substantially as set forth.

8. The combination with two pneumatic
ejectors of the character described, a main
45 valve and a slide-valve for each of them, a controlling valve device consisting of a divided piston-valve adapted to be reciprocated by means of compressed air, a cylindrical casting or body, a liner fixed therein and in which said valve is reciprocated, said casting
50 opening toward the compressed-air store, an outlet opening toward each main valve, said openings situated between the center and the ends, a small opening at each end of the controlling-valve communicating with the one
55 end of each main valve and therethrough with a port of their respective slide-valves; of means for holding the controlling-valve against motion at either end of its stroke, for the purposes set forth.

9. The combination with a slide-valve and
60 its casing, a cylindrical casing, a controlling divided piston-valve working therein, a main-valve chest bolted to each end of said casing, the latter having a central inlet, an outlet
65 opening toward each main valve and a small passage at each end in communication with one end of each main-valve chest and there-

through with a port in the slide-valve casing, of means for driving the controlling-valve to one end or the other of its stroke, and means
70 for holding it there, for the purposes set forth.

10. The combination with a slide-valve and its casing, a pneumatically-operated twin-piston controlling-valve, its casing, a main-valve chest bolted to each end of said casing,
75 the latter having a central inlet in communication with a source of compressed-air supply, an outlet opening toward each main valve, and a small passage at each end communicating with one end of each main-valve chest
80 and therethrough with a port in the aforesaid slide-valve casing; of means for driving the controlling-valve to one end or the other of its stroke by compressed air and for holding it there, substantially as and for the purposes
85 set forth.

11. The combination with a pneumatic ejector, valved sewage inlet and outlet pipes connected therewith, a float therein, and a slide-valve operated by said float; of a double main
90 valve, a source of supply of air under pressure connected to opposite ends of said main valve and in which the slide-valve is interposed to control the supply of air-pressure to one or the other end of said main valve and
95 reciprocate the same, means for supplying compressed air to the main valve, and a circuit of pipes rising above the ejector and said main valve and having its terminals connected with the main-valve outlet and with the
100 ejector respectively, for the purposes set forth.

12. A pneumatic ejector provided with a sewage-inlet pipe and valve and sewage-outlet pipe and valve and a float in combination with a slide-valve operated by the float and
105 communicating with the store of compressed air, said slide-valve combined with a main double valve, which by a small conduit from each end communicates with the slide-valve for being impelled thereby in one direction
110 or the other and which is provided with an outlet for compressed air to the ejector, and an inlet-pipe for compressed air, a box pedestal upon which the combined slide-valve and main valve is fixed said pedestal having
115 one chamber communicating with the ejector and another chamber communicating with the main-valve outlet, and a pipe carried up to a considerable height above the ejector which pipe unites the two chambers substantially as and for the purpose set forth.

13. The combination with a pneumatic ejector of the character described, its float and float-rod, and a fluid-operated main valve controlling the admission of compressed air to
125 said ejector; of a valve mechanism comprising a valve-box in communication with a source of motive-fluid supply and with the main-valve casing, a slide-valve in said box controlling the flow of motive fluid thereto and therefrom,
130 a rock-shaft working in an open chamber in said box, and two levers on said shaft respectively connected with the slide-valve and float-rod, whereby when said slide-valve is

moved by the rising of the float-rod motive fluid is admitted to the main-valve casing to actuate the main valve and cause compressed air to flow to the ejector, substantially as set forth.

5 14. The combination with a pneumatic ejector of the character described, its float and float-rod and a fluid-operated main valve controlling the admission of compressed air to
10 said ejector; of a slide-valve working in a chamber in the main-valve casing said chamber connected with a source of motive-fluid supply and said slide-valve controlling the
15 flow of motive fluid to said main valve, a rock-shaft, a lever thereon working in the exhaust and connected with the under side of said slide-valve, a second lever on said shaft
20 connected with the float-rod, a support for the main valve on the ejector and having two chambers one in communication with the outlet of the main-valve casing and the other
25 with the ejector, and a rising pipe-circuit connecting said two chambers, whereby when the slide-valve is actuated by the rise of the float-rod, motive fluid is admitted to the main valve
30 to actuate the same and cause compressed air to flow through the rising circuit into the ejector, for the purpose set forth.

15. The combination with a pneumatic ejector of the character described, its float and float-rod, and a fluid-operated main valve controlling the admission of compressed air to
30 said ejector; of a slide-valve working in a chamber in the main-valve casing, said chamber
35 connected with a source of motive-fluid

supply and said slide-valve controlling the flow of motive fluid to said main valve, a rock-shaft, a lever thereon working in the exhaust and connected with the under side of said
40 slide-valve, a second lever on said shaft connected with the float-rod, a support for the main valve on the ejector and having two chambers one in communication with the outlet of the main-valve casing and the other
45 with the ejector, a rising pipe-circuit connecting said two chambers, whereby when the slide-valve is actuated by the rise of the float-rod motive fluid is admitted to the main valve to actuate the same and cause compressed air
50 to flow through the rising circuit into the ejector, and a strainer at the highest point of said pipe-circuit, for the purpose set forth.

16. The combination of the ejector, the float therein, a spindle partially rotated thereby,
55 a lever on said spindle for operating the slide-valve, the slide-valve, the body or casting wherein it works provided with suitable ports and passages, and a liner on the valve-face,
60 said liner having a hole which as the liner is turned end for end adapts the body-casting for a right-hand or left-hand disposition substantially as set forth.

In testimony that we claim the foregoing as our invention we have signed our names in presence of two subscribing witnesses.

ISAAC SHONE.

EDWIN AULT.

Witnesses:

FRED. C. HARRIS,

V. JENSEN.