



- (51) International Patent Classification: *F21S 10/04* (2006.01)
- (21) International Application Number: PCT/US2014/013923
- (22) International Filing Date: 30 January 2014 (30.01.2014)
- (25) Filing Language: English
- (26) Publication Language: English
- (30) Priority Data: 61/758,602 30 January 2013 (30.01.2013) US
- (71) Applicant: CANDELLA LLC [US/US]; 4000 W. Metropolitan Dr., Suite 400, Orange, California 92868 (US).
- (72) Inventor: PATTON, Douglas; 15 Bloomdale, Irvine, California 92614 (US).
- (74) Agents: DEAN, Ryan S. et al.; Fish & Associates, PC, 2603 Main Street, Suite 1000, Irvine, California 92614 (US).
- (81) Designated States (unless otherwise indicated, for every kind of national protection available): AE, AG, AL, AM, AO, AT, AU, AZ, BA, BB, BG, BH, BN, BR, BW, BY, BZ, CA, CH, CL, CN, CO, CR, CU, CZ, DE, DK, DM, DO, DZ, EC, EE, EG, ES, FI, GB, GD, GE, GH, GM, GT, HN, HR, HU, ID, IL, IN, IR, IS, JP, KE, KG, KN, KP, KR, KZ, LA, LC, LK, LR, LS, LT, LU, LY, MA, MD, ME, MG, MK, MN, MW, MX, MY, MZ, NA, NG, NI, NO, NZ, OM, PA, PE, PG, PH, PL, PT, QA, RO, RS, RU, RW, SA, SC, SD, SE, SG, SK, SL, SM, ST, SV, SY, TH, TJ, TM, TN, TR, TT, TZ, UA, UG, US, UZ, VC, VN, ZA, ZM, ZW.
- (84) Designated States (unless otherwise indicated, for every kind of regional protection available): ARIPO (BW, GH, GM, KE, LR, LS, MW, MZ, NA, RW, SD, SL, SZ, TZ, UG, ZM, ZW), Eurasian (AM, AZ, BY, KG, KZ, RU, TJ, TM), European (AL, AT, BE, BG, CH, CY, CZ, DE, DK,

[Continued on next page]

(54) Title: ELECTRIC LIGHTING DEVICES HAVING A NON-HOMOLOGOUS PROJECTION SCREEN

FIG. 4

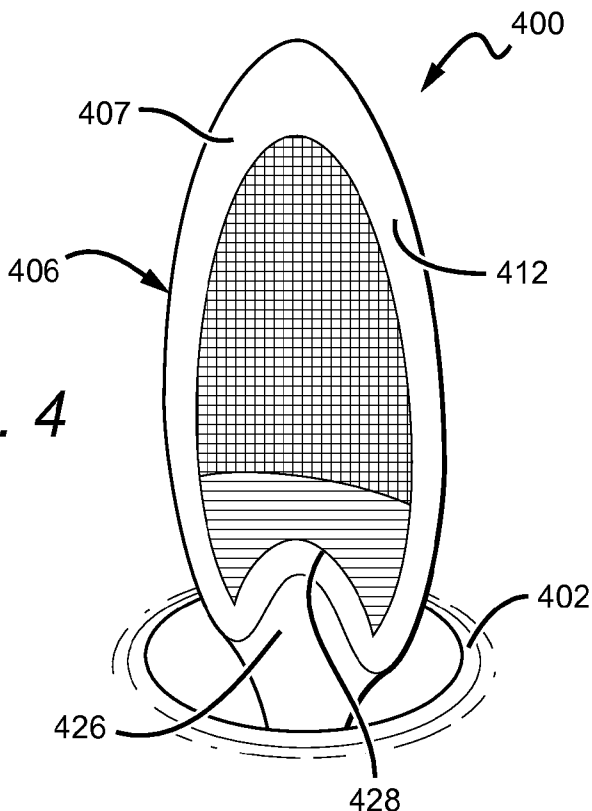

(57) Abstract: Various embodiments of electric lighting devices having projection screens are described. Some embodiments include a housing, a projection screen coupled to the housing and comprising a first region that is translucent or transparent and a set of light sources configured to emit light onto a surface of the projection screen and include a projection screen having a laminate structure, while other embodiments include a video screen that is embedded within the projection screen.

WO 2014/120964 A1

EE, ES, FI, FR, GB, GR, HR, HU, IE, IS, IT, LT, LU,
LV, MC, MK, MT, NL, NO, PL, PT, RO, RS, SE, SI, SK,
SM, TR), OAPI (BF, BJ, CF, CG, CI, CM, GA, GN, GQ,
GW, KM, ML, MR, NE, SN, TD, TG).

— *before the expiration of the time limit for amending the
claims and to be republished in the event of receipt of
amendments (Rule 48.2(h))*

Published:

— *with international search report (Art. 21(3))*

ELECTRIC LIGHTING DEVICES HAVING A NON-HOMOLOGOUS PROJECTION SCREEN

[0001] This application claims the benefit of priority to U.S. provisional application having serial no. 61/758,602 filed on January 30, 2013. This and all other extrinsic materials discussed herein are incorporated by reference in their entirety. Where a definition or use of a term in an incorporated reference is inconsistent or contrary to the definition of that term provided herein, the definition of that term provided herein applies and the definition of that term in the reference does not apply.

Field of the Invention

[0002] The field of the invention is electric lighting devices, and especially lighting devices configured to simulate a flickering flame.

Background

[0003] The following background discussion includes information that may be useful in understanding the present invention. It is not an admission that any of the information provided herein is prior art or relevant to the presently claimed invention, or that any publication specifically or implicitly referenced is prior art.

[0004] Various electric lights are known in the art. See, *e.g.*, U.S. pat. no. 8132936 to Patton *et al.*, U.S. pat. no. 8070319 to Schnuckle *et al.*, U.S. pat. no. 7837355 to Schnuckle *et al.*, U.S. pat. no. 7261455 to Schnuckle *et al.*, U.S. pat. no. 7159994 to Schnuckle *et al.*, U.S. pat. publ. no. 2011/0127914 to Patton *et al.*, U.S. pat. no. 7350720 to Jaworski *et al.*; U.S. patent no. 7686471 to Reichow; U.S. pat. publ. no. 2005/0285538 to Jaworski *et al.* (publ. Dec. 2005); U.S. pat. no. 7481571 to Bistrizky *et al.*; U.S. pat. publ. no. 2008/0031784 to Bistrizky *et al.* (publ. Feb. 2008); U.S. pat. publ. no. 2006/0125420 to Boone *et al.* (publ. June 2006); U.S. pat. publ. no. 2007/0127249 to Medley *et al.* (publ. June 2007); U.S. pat. publ. no. 2008/0150453 to Medley *et al.* (publ. June 2008); U.S. pat. publ. no. 2005/0169666 to Porchia, *et al.* (publ. Aug. 2005); U.S. pat. no. 7503668 to Porchia, *et al.*; U.S. pat. no. 7824627 to Michaels, *et al.*; U.S. pat. publ. no. 2006/0039835 to Nottingham *et al.* (publ. Feb. 2006); U.S. pat. publ. no. 2008/0038156 to Jaramillo (publ. Feb. 2008); U.S. pat. publ. no. 2001/0033488 to Chliwnyj ; U.S. pat. publ. no.

2008/0130266 to DeWitt *et al.* (publ. June 2008); U.S. pat. publ. no. 2012/0024837 to Thompson (publ. Feb. 2012); U.S. pat. publ. no. 2011/0134628 to Pestl *et al.* (publ. June 2011); U.S. pat. publ. no. 2011/0027124 to Albee *et al.* (publ. Feb. 2011); U.S. pat. publ. no. 2012/0020052 to McCavit *et al.* (publ. Jan. 2012); U.S. pat. publ. no. 2012/0093491 to Browder *et al.* (publ. Apr. 2012); and European publ. no. 1878449. However, while various mechanisms have been used to more closely simulate a flickering flame of a candle, such mechanisms suffer from one or more disadvantages.

[0005] Unless the context dictates the contrary, all ranges set forth herein should be interpreted as being inclusive of their endpoints, and open-ended ranges should be interpreted to include commercially practical values. Similarly, all lists of values should be considered as inclusive of intermediate values unless the context indicates the contrary.

[0006] Thus, there is still a need for improved electric candles and other light sources that more realistically imitate a flickering flame.

Summary of the Invention

[0007] The inventive subject matter provides apparatus, systems and methods in which one can simulate an appearance of a flame in an electric lighting device, such as an electric candle or light bulb. Preferred devices include a projection screen coupled to a housing such that some or all of the projection screen extends from the housing.

[0008] The projection screen preferably includes at least a first translucent, and more preferably transparent, region to simulate a more realistic flame effect and is less obtrusive when the device is off. In some contemplated embodiments, the bottom portion of the projection screen could be translucent or transparent, while in other embodiments, a periphery of the projection screen could be transparent, or could fade to transparent across a width of its periphery.

[0009] The device can also include a set of light sources that emit light onto a surface of the projection screen.

[0010] Alternatively or additionally, the projection screen can comprise a laminate having a plurality of layers. As a few examples, the layers can advantageously alter a visual makeup of

the projection screen by adding clear or translucent regions, frosted areas, holographic material, reflective portions, refractive elements, a luminescent layer, and so forth.

[0011] In other embodiments, the projection screen could have an irregular outer surface.

[0012] In one aspect, electric lighting devices can include a housing having a memory and a video screen extending from the housing. The memory preferably is configured to store one or more media files. A microprocessor coupled with the memory and video screen can present one or more of the media files on the video screen.

[0013] Various objects, features, aspects and advantages of the inventive subject matter will become more apparent from the following detailed description of preferred embodiments, along with the accompanying drawing figures in which like numerals represent like components.

Brief Description of The Drawing

[0014] Fig. 1 is a vertical cross-section view of one embodiment of an electric lighting device.

[0015] Figs. 2A-2B are a front view and a side view of one embodiment of a projection screen.

[0016] Fig.3 is a front view of another embodiment of a projection screen.

[0017] Fig. 4 is a front view of another embodiment of an electric lighting device.

[0018] Fig 5 is an exploded view of one embodiment of a projection screen having a laminate.

[0019] Figs. 6A-6B are an exploded view and a side view of another embodiment of a projection screen having a laminate.

[0020] Fig.7 is an exploded view of another embodiment of a projection screen having a laminate.

[0021] Fig. 8 is a front view of another embodiment of a projection screen.

[0022] Fig. 9 is an enlarged view of a surface of projection screen having an accordion surface.

[0023] Figs. 10-11 are vertical cross-section views of two embodiments of an electric lighting device having a video screen.

Detailed Description

[0024] It should be noted that while the following description is drawn to a computer/server flame simulation system, various alternative configurations are also deemed suitable and may employ various computing devices including servers, interfaces, systems, databases, agents, peers, engines, controllers, or other types of computing devices operating individually or collectively. One should appreciate the computing devices comprise a processor configured to execute software instructions stored on a tangible, non-transitory computer readable storage medium (*e.g.*, hard drive, solid state drive, RAM, flash, ROM, etc.). The software instructions preferably configure the computing device to provide the roles, responsibilities, or other functionality as discussed below with respect to the disclosed apparatus. In especially preferred embodiments, the various servers, systems, databases, or interfaces exchange data using standardized protocols or algorithms, possibly based on HTTP, HTTPS, AES, public-private key exchanges, web service APIs, known financial transaction protocols, or other electronic information exchanging methods. Data exchanges preferably are conducted over a packet-switched network, the Internet, LAN, WAN, VPN, or other type of packet switched network.

[0025] The following discussion provides many example embodiments of the inventive subject matter. Although each embodiment represents a single combination of inventive elements, the inventive subject matter is considered to include all possible combinations of the disclosed elements. Thus if one embodiment comprises elements A, B, and C, and a second embodiment comprises elements B and D, then the inventive subject matter is also considered to include other remaining combinations of A, B, C, or D, even if not explicitly disclosed.

[0026] **Figure 1** illustrates one embodiment of an electric lighting device 100 that simulates a flickering flame having a housing 102. Preferred devices 100 include a projection screen 106 that may have a tear-drop or other shape to simulate the look of a flame. **Figure 1** shows a cutout of a projection screen having a tear-drop shape with a concavity. Although the projection screen 106 can be static with respect to the housing 102, it is preferred that the projection screen 106 be coupled to the housing 102 such that the projection screen can be moved using an

electromagnet, a fan, or other drive mechanism(s). The projection screen 106 can include (i) a face 112 and (ii) a back that faces away from the face 112, and may have one or more concavities.

[0027] The specific construction and/or materials comprising the projection screen can vary, and is further discussed below. For example, the screen could be opaque, translucent, or transparent, or combinations thereof. In addition, the projection screen could have multiple layers and/or multiple materials composing the projection screen. In some embodiments, the projection screen could be co-injection molded or insert injection molded to create a projection screen comprising different materials and/or different transparencies. For example, the projection screen could have an outer edge that has a greater transparency than a middle portion of the projection screen. It is also contemplated that the projection screen can have multiple faces, such as three or more faces, and/or could comprise various shapes including a cone, a sphere, or an inverted tear drop, for example.

[0028] At least a portion of the projection screen 106 extends from the housing 102, and in some embodiments, an upper portion 114 can extend from the housing 102 while a lower portion 116 can be disposed within the housing 102. However, where the projection screen is static, it is contemplated that all or substantially all of the projection screen 106 will extend from the housing 102.

[0029] Device 100 includes first, second, and third light sources 120, 122, and 124, respectively, disposed within the housing 102, and configured to emit light on to the face 112 of the projection screen 106, and preferably on to an outer surface 110 of the screen 106. Of course, the light sources could be disposed outside of the housing 102 without departing from the scope of the inventive subject matter discussed herein. Rather, than three individual light sources 120, 122, 124, it is alternatively contemplated that one or more of the light sources 120, 122, 124 could comprise a set of micro-LEDs or other lights. Thus, for example, instead of a traditional LED that may have a diameter of 1 mm, 6-8 micro-LEDs or more could be used in the same space. In such embodiments, it is especially preferred that the lights comprise RGB lights such that a variety of colors of light could be produced. It is also contemplated that the light sources 120,

122, 124 could collectively comprise a RGB light, and could be used in conjunction with additional RGB lights or other light sources.

[0030] It is especially preferred that each of the light sources 120, 122, and 124 emits light at a predominant wavelength that is different from the other light sources. Thus, for example, the first light source 120 could emit visible light in the orange spectrum (*e.g.*, a predominant wavelength of between 590 nm - 620 nm), the second light source 122 could emit white light, and the third light source 124 could emit visible light in the blue spectrum (*e.g.*, a predominant wavelength of between 450 nm - 495 nm).

[0031] In some contemplated embodiments, the light sources 120, 122, and 124 can each be disposed at an angle with respect to the projection screen 106 that is different from the other light sources. This enables light emitted from the light sources 120, 122, and 124 to be directed at different portions of the projection screen 106. For example, light emitted from the first light source 120 can be directed predominantly at an upper portion of the outer surface 110 of the projection screen 106, light emitted from the second light source 122 can be directed predominantly at a middle portion of the outer surface 110 of the projection screen 106 below the upper portion, and light emitted from the third light source 124 can be directed predominantly at a lower portion of the outer surface 110 of the projection screen 106 below the middle portion.

[0032] In this manner, the visible lighting effect on the projection screen 106 can include an orange color around a periphery of the projection screen 106 with a blue color at its bottom.

[0033] Each of the light sources 120, 122, 124 can include or otherwise interact with a separate lens, or alternatively, a single lens could be used in conjunction with the light sources 120, 122, and 124.

[0034] **Figures 2A-2B** illustrate one embodiment of a projection screen 206 for use in an electric lighting device. The projection screen 206 can include a translucent, and preferably transparent, outer perimeter or periphery 207 shown as the area between the dashed lines. In some embodiments, the perimeter 207 can fade outwardly from opaque to clear or semi-clear in the direction shown by arrows 209. It is especially preferred that the outer perimeter is transparent or 15% clear plastic.

[0035] It is contemplated that the projection screen 206 could be manufactured using a silkscreen that fades from its interior to its exterior and is printed on. In other embodiments, the projection screen 206 could comprise a 2-3 laminated plastic piece having a clear outer edge and a solid interior. In still further embodiments, the projection screen could be made via injection molding.

[0036] As shown in **Figure 2B**, light sources 220 and 222 can emit light on to a face 212 of the projection screen 206, and each emit a different predominant color of light (here, blue and yellow/orange). It is also contemplated that three or more light sources could be used, each of which emits a different predominant color of light.

[0037] It is contemplated that a portion of the surface of the projection screen 206 could include an etching to form a non-planar surface. The projection screen 206 could also include molded-in refractive elements that refract light when hit and can be used to create diverse flame effects when light from a LED or other light source impinge upon the refractive element.

[0038] **Figure 3** illustrates another embodiment of a projection screen 306 for use in an electric lighting device, and having clear bottom portion 326 where a support member can pass through a hole 327 in the screen 306 to allow movement of the projection screen 306. It is contemplated that the projection screen 306 could comprise 1-4 layers of plastic, each layer having a thickness of approximately of 0.005 mm.

[0039] **Figure 4** illustrates a device 400 for simulating a flame effect that includes a housing 402, from which a projection screen 406 extends. The projection screen 406 can include an outer perimeter 407 that fades to clear along its width, and a clear bottom portion 426. Bottom portion advantageously includes an inverted arc 428 that simulates the shape of a flame. Thus, as shown in the figure, the projection screen 406 can have levels of transparency across its diameter. With respect to the remaining numerals in **Figure 4**, the same considerations for like components with like numerals of **Figure 2** apply.

[0040] **Figure 5** illustrates another embodiment of a projection screen 506 that includes a laminate having first, second, and third layers 532, 534, and 536, respectively, which collectively comprise the upper portion 514 of the projection screen 506. Contemplated layers could include

a reflective layer, a layer having holographic material, an opaque layer, a clear layer, a frosted layer, and so forth.

[0041] **Figures 6A-6B** illustrate another embodiment of a projection screen 606 comprising a laminate 607. The laminate 607 can include three layers 660, 662, 664 or sheets of various plastic and a clear plastic substrate layer 666. The layers advantageously allow for different effects depending on the specific layer used, and also allow for different materials to be embedded within the projection screen 606. For example, one layer could have a reflective surface, which can alter the flame simulation effect of the device.

[0042] In this embodiment, the first layer 660 could comprise a 20% frosted layer, for example, and the second layer 662 could comprise a reflective layer that is approximately 30% transparent. The third layer 664 can comprise an opaque layer that fades to clear about its periphery. The opaque layer advantageously helps prevent light from bleeding through the central portion of the projection screen 606 while allowing for a clear perimeter.

[0043] Projection screen 606 can further include a magnet 663 and be supported in a device via wire 665.

[0044] **Figure 7** illustrates another possible combination of layers to form a projection screen.

[0045] **Figure 8** illustrates another embodiment of a projection screen 806 having a holographic material 870 disposed in an inner portion thereof. The holographic material could comprise colors and/or shapes etched into foil, for example, and may comprise an image of a flame that moves depending on the viewing angle of the holographic material 870. The use of holographic material 870 advantageously allows the projection screen 806 to sparkle with real flame-like colors when hit with light.

[0046] Preferably, the holographic material 870 is encased or molded between transparent or semi-transparent plastic to prevent the material 870 from being dislodged. With respect to the remaining numerals in **Figure 8**, the same considerations for like components with like numerals of **Figure 3** apply.

[0047] **Figure 9** illustrates an enlarged view of an outer surface of one embodiment of a projection screen 906 having a non-planar and irregular surface. In this embodiment, the surface can include an accordion surface 902 on at least a portion thereof. The accordion surface 902 comprises a first set of faces 903 and a second set of faces 904. In some embodiments, one of the faces 903 or 904 can have a reflective surface.

[0048] In **Figure 10**, another embodiment of an electric lighting device 1000 is shown that is configured to simulate an appearance of a flame. Device 1000 can include a candle-shaped housing, although other form factors are contemplated.

[0049] Device 100 can further include memory 1010 disposed on a circuit board 1012, which is configured to store one or more media files. Board 1012 preferably also includes a microprocessor 1014 configured to present the one or more media files on a video screen 1008. Video screen 1008 can extend from the housing 1002 and have an on and off state. Preferably, the screen 1008 is embedded into a substrate 1006 that may have a clear perimeter 1007. It is contemplated that video screen 1008 and/or substrate 1006 could be shaped to resemble a candle flame and may have a concave surface.

[0050] In especially preferred embodiments, the video screen 1008 is transparent in the off state to hide the screen 1008 from view when not on.

[0051] In some contemplated embodiments, the video screen 1008 can have a surface area of no more than 9 cm².

[0052] Device 1000 can further include a wireless network card 1020 configured to wirelessly receive a command signal or media files from a remote device. The microprocessor 1014 can control the video screen as a function of the received command. Contemplated commands include, for example, change the video screen to the on state, change the video screen to the off state, and/or play a specific media file stored in the memory.

[0053] **Figure 11** illustrates another embodiment of an electric lighting device 1100 is shown that is configured to simulate an appearance of a flame and has a housing 1102. In this embodiment, the memory and microprocessor can be embedded into the projection screen 1106,

which eliminates the video cables to the projection screen 1106 and allows for movement of the projection screen 1106 with respect to the housing 1102.

[0054] An electromagnet 1164 can be used to move the projection screen 1106 through interaction of magnet 1162 in projection screen 1106 with the electromagnetic field generated by the electromagnet 1164. Projection screen 1106 can also include a battery that can be charged via induction using an inductive coil 1166. Rather than an electromagnet, a fan or motor could be used to cause movement of the projection screen 1106.

[0055] In such embodiments, it is contemplated that the projection screen 1106 comprise a laminate between which wiring from the microprocessor 1114 to the video screen 1108 can be disposed. With respect to the remaining numerals in **Figure 11**, the same considerations for like components with like numerals of **Figure 10** apply.

[0056] In some embodiments, the video screen could comprise flexible film with LEDs, and could have different colors.

[0057] In some embodiments, the numbers expressing quantities of ingredients, properties such as concentration, reaction conditions, and so forth, used to describe and claim certain embodiments of the invention are to be understood as being modified in some instances by the term “about.” Accordingly, in some embodiments, the numerical parameters set forth in the written description and attached claims are approximations that can vary depending upon the desired properties sought to be obtained by a particular embodiment. In some embodiments, the numerical parameters should be construed in light of the number of reported significant digits and by applying ordinary rounding techniques. Notwithstanding that the numerical ranges and parameters setting forth the broad scope of some embodiments of the invention are approximations, the numerical values set forth in the specific examples are reported as precisely as practicable. The numerical values presented in some embodiments of the invention may contain certain errors necessarily resulting from the standard deviation found in their respective testing measurements.

[0058] As used in the description herein and throughout the claims that follow, the meaning of “a,” “an,” and “the” includes plural reference unless the context clearly dictates otherwise. Also,

as used in the description herein, the meaning of “in” includes “in” and “on” unless the context clearly dictates otherwise.

[0059] The recitation of ranges of values herein is merely intended to serve as a shorthand method of referring individually to each separate value falling within the range. Unless otherwise indicated herein, each individual value is incorporated into the specification as if it were individually recited herein. All methods described herein can be performed in any suitable order unless otherwise indicated herein or otherwise clearly contradicted by context. The use of any and all examples, or exemplary language (e.g. “such as”) provided with respect to certain embodiments herein is intended merely to better illuminate the invention and does not pose a limitation on the scope of the invention otherwise claimed. No language in the specification should be construed as indicating any non-claimed element essential to the practice of the invention.

[0060] Groupings of alternative elements or embodiments of the invention disclosed herein are not to be construed as limitations. Each group member can be referred to and claimed individually or in any combination with other members of the group or other elements found herein. One or more members of a group can be included in, or deleted from, a group for reasons of convenience and/or patentability. When any such inclusion or deletion occurs, the specification is herein deemed to contain the group as modified thus fulfilling the written description of all Markush groups used in the appended claims.

[0061] As used herein, and unless the context dictates otherwise, the term "coupled to" is intended to include both direct coupling (in which two elements that are coupled to each other contact each other) and indirect coupling (in which at least one additional element is located between the two elements). Therefore, the terms "coupled to" and "coupled with" are used synonymously.

[0062] It should be apparent to those skilled in the art that many more modifications besides those already described are possible without departing from the inventive concepts herein. The inventive subject matter, therefore, is not to be restricted except in the scope of the appended claims. Moreover, in interpreting both the specification and the claims, all terms should be interpreted in the broadest possible manner consistent with the context. In particular, the terms

“comprises” and “comprising” should be interpreted as referring to elements, components, or steps in a non-exclusive manner, indicating that the referenced elements, components, or steps may be present, or utilized, or combined with other elements, components, or steps that are not expressly referenced. Where the specification claims refers to at least one of something selected from the group consisting of A, B, C ... and N, the text should be interpreted as requiring only one element from the group, not A plus N, or B plus N, etc.

CLAIMS

What is claimed is:

1. An electric lighting device configured to simulate an appearance of a flame, comprising:
a housing;
a projection screen coupled to the housing and comprising a first region that is translucent or transparent; and
a set of light sources configured to emit light onto a surface of the projection screen.
2. The device of claim 0, wherein the first region is disposed at a bottom portion of the projection screen.
3. The device of claim 0 or 2, wherein a top of the first region comprises an arc.
4. The device of any of claims 1-3, wherein the first region fades across its width or length from opaque to transparent.
5. The device of any of claims 1-4, further comprising a second region that is translucent or transparent and that is disposed about a periphery of the projection screen.
6. The device of claim 5, wherein the second region fades outwardly from opaque to transparent.
7. The device of claim 5, wherein the projection screen further comprises an inner portion surrounded by the first and second regions.
8. The device of claim 7, wherein an outer perimeter of the inner portion comprises first and second arcs that meet at first and second points.
9. The device of claim 0, wherein the first region is disposed about a periphery of the projection screen.
10. The device of claim 9, wherein the first region fades outwardly from opaque to transparent.

11. The device of claim 9 or 10, further comprising a second region that is translucent or transparent and is disposed at a bottom portion of the projection screen.
12. The device of claim 11, wherein the second region fades across its width or length from opaque to transparent.
13. The device of any of claims 1-12, wherein the projection screen comprises a laminate having a plurality of layers.
14. The device of claim 13, wherein at least one of the layers comprises a reflective surface.
15. The device of claim 13 or 14, wherein at least one of the layers comprises a holographic material.
16. The device of claim 15, wherein the holographic material comprises an image of a flame.
17. The device of claim 15 or 16, wherein the holographic material comprises a plurality of colors.
18. The device of any of claims 15-17, wherein the set of light sources are configured to emit light onto the holographic material.
19. The device of any of claims 13-18, where the projection screen has levels of transparency across a diameter of the projection screen.
20. The device of any of claims 1-19, wherein a surface of the projection screen comprises an etching.
21. The device of any of claims 1-20, wherein a surface of the projection screen is non-planar.
22. The device of any of claims 1-21, wherein at least a portion of the projection screen has a reflective surface.
23. The device of any of claims 1-22, wherein the projection screen comprises layers of different levels of transparency.

24. The device of any of claims 1-23, wherein at least a portion of the projection screen comprises an accordion surface.
25. The device of claim 24, wherein at least a portion of the accordion surface comprises a reflective surface.
26. The device of claim 24 or 25, wherein the accordion surface includes first and second sets of faces, wherein the first set of faces face in a first direction, and the second set of faces face in a second direction.
27. The device of claim 26, wherein the first set of faces each comprise a reflective surface.
28. The device of any of claims 1-27, wherein the projection screen comprises a set of refractive elements.
29. The device of any of claims 1-28, wherein the set of light sources comprises first, second, and third lights, each of which emits a predominant color of light that is different from the other lights.
30. The device of claim 29, wherein the first, second, and third lights emit orange light, white light and blue light, respectively.
31. The device of claim 29 or 30, wherein the set of light sources each emit light on to a face of the projection screen.
32. The device of claim 29 or 30, wherein at least one of the lights emits light on to a back of the projection screen.
33. The device of any of claims 1-32, wherein at least a portion of the projection screen extends from the housing.
34. The device of any of claims 1-33, wherein the projection screen comprises a central axis that bisects the projection screen vertically.
35. The device of claim 34, wherein the set of light sources comprises first, second, and third light sources, each of which is coupled to the housing and disposed with respect to the projection

screen such that a focal point of each of the first, second, and third light sources is at the central axis of the projection screen at rest.

36. The device of any of claims 1-35, wherein the projection screen comprises a laminate having at least two layers.

37. The device of claim 36, wherein at least one of the layers is frosted.

38. The device of any of claims 1-37, wherein the projection screen is affixed to the housing.

39. The device of any of claims 1-37, wherein the projection screen is pivotally coupled to the housing.

40. The device of claim 39, further comprising a drive mechanism configured to cause movement of the projection screen with respect to the housing.

41. The device of claim 40, wherein the drive mechanism comprises a coil of wire and a signal generator providing time-varying current to the coil to create a time-varying electromagnetic field, and wherein the projection screen comprises a magnet, and wherein the coil is disposed within the housing with respect to the magnet such that the electromagnetic field causes movement of the projection screen.

42. The device of claim 40, wherein the drive mechanism comprises a fan, and wherein the fan is disposed within the housing with respect to the projection screen such that an airflow from the fan causes movement of the projection screen.

43. An electric lighting device configured to simulate an appearance of a flame, comprising:
a housing;
a projection screen coupled to the housing and comprising a laminate having a plurality of layers; and
a set of light sources configured to emit light onto a surface of the projection screen.

44. The device of claim 43, wherein the projection screen further comprises a first clear region.

45. The device of claim 44, wherein the first clear region is transparent or 15% clear plastic.

46. The device of claim 44 or 45, wherein the first clear region is disposed at a bottom portion of the projection screen.
47. The device of claim 46, wherein a top of the first clear region comprises an arc.
48. The device of claim 47, wherein the arc fades outwardly from opaque to transparent.
49. The device of any of claims 44-48, further comprising a second region that is translucent or transparent and is disposed about a periphery of the projection screen.
50. The device of claim 49, wherein the second region fades outwardly from opaque to transparent.
51. The device of claim 49, wherein the second region is transparent or 15% clear plastic.
52. The device of claim 51, wherein the first clear region is disposed about a periphery of the projection screen.
53. The device of claim 52, wherein the first clear region fades outwardly from opaque to transparent.
54. The device of claim 52 or 53, wherein the projection screen further comprises a second clear region disposed at a bottom portion of the projection screen.
55. The device of claim 54, wherein the second clear region fades from opaque to transparent.
56. The device of any of claims 43-55, wherein at least one of the layers comprises a reflective surface.
57. The device of any of claims 43-56, wherein at least one of the layers comprises a holographic material.
58. The device of claim 57, wherein the holographic material comprises an image of a flame.
59. The device of claim 57 or 58, wherein the holographic material comprises a plurality of colors.

60. The device of any of claims 57-59, wherein the set of light sources are configured to emit light onto the holographic material.
61. The device of any of claims 43-60, where the projection screen has levels of transparency across a diameter of the projection screen.
62. The device of any of claims 43-61, wherein a surface of the projection screen comprises an etching.
63. The device of any of claims 43-62, wherein a surface of the projection screen is non-planar.
64. The device of any of claims 43-63, wherein at least a portion of the projection screen has a reflective surface.
65. The device of any of claims 43-64, wherein at least a portion of the projection screen comprises an accordion surface.
66. The device of claim 65, wherein at least a portion of the accordion surface comprises a reflective surface.
67. The device of claim 65 or 66, wherein the accordion surface includes first and second sets of faces, wherein the first set of faces face in a first direction, and the second set of faces face in a second direction.
68. The device of claim 67, wherein the first set of faces each comprise a reflective surface.
69. The device of any of claims 43-68, wherein the projection screen comprises a set of refractive elements.
70. The device of any of claims 43-69, wherein the set of light sources comprises first, second, and third lights, each of which emits a predominant color of light that is different from the other lights.
71. The device of claim 70, wherein the first, second, and third lights emit orange light, white light and blue light, respectively.

72. The device of claim 70 or 71, wherein the set of light sources each emit light on to a face of the projection screen.

73. The device of claim 70 or 71, wherein at least one of the lights emits light on to a back of the projection screen.

74. The device of any of claims 43-73, wherein at least a portion of the projection screen extends from the housing.

75. The device of any of claims 43-74, wherein the projection screen comprises a central axis that bisects the projection screen vertically.

76. The device of claim 75, wherein the set of light sources comprises first, second, and third light sources, each of which is coupled to the housing and disposed with respect to the projection screen such that a focal point of each of the first, second, and third light sources is at the central axis of the projection screen at rest.

77. The device of any of claims 43-76, wherein the projection screen comprises a laminate having at least two layers.

78. The device of claim 77, wherein at least one of the layers is frosted.

79. The device of claim 77, wherein the laminate comprises a frosted layer, a reflective layer, a clear substrate, and an opaque layer that fades outwardly to clear.

80. The device of claim 77, wherein the laminate comprises two to four layers of plastic, each having a thickness of no more than 0.01 mm.

81. The device of any of claims 43-80, wherein the projection screen comprises an irregular, outer surface. <Surface variations; Molded in lines / surface to sparkle>

82. The device of any of claims 43-81, wherein the projection screen is affixed to the housing.

83. The device of any of claims 43-81, wherein the projection screen is pivotally coupled to the housing.

84. The device of claim 83, further comprising a drive mechanism configured to cause movement of the projection screen with respect to the housing.
85. The device of claim 84, wherein the drive mechanism comprises a coil of wire and a signal generator providing time-varying current to the coil to create a time-varying electromagnetic field, and wherein the projection screen comprises a magnet, and wherein the coil is disposed within the housing with respect to the magnet such that the electromagnetic field causes movement of the projection screen.
86. The device of claim 84, wherein the drive mechanism comprises a fan, and wherein the fan is disposed within the housing with respect to the projection screen such that an airflow from the fan causes movement of the projection screen.
87. An electric lighting device configured to simulate an appearance of a flame, comprising:
a housing;
a projection screen coupled to the housing and comprising an irregular outer surface; and
a set of light sources configured to emit light onto the irregular outer surface.
88. The device of claim 87, wherein at least a portion of the outer surface comprises an accordion surface.
89. The device of claim 88, wherein at least a portion of the accordion surface comprises a reflective surface.
90. The device of claim 88 or 89, wherein the accordion surface includes first and second sets of faces, wherein the first set of faces face in a first direction, and the second set of faces face in a second direction.
91. The device of claim 90, wherein the first set of faces each comprise a reflective surface.
92. The device of any of claims 87-91, wherein the projection screen comprises a set of molded-in refractive elements, and wherein at least some of the light impinges on the refractive elements.
93. The device of any of claims 87-92, wherein the outer surface comprises an etching.

94. The device of any of claims 87-93, wherein the outer surface comprises a solid color interior.

95. The device of any of claims 87-94, wherein the projection screen fades outwardly from an opaque central portion to a clear periphery along its radius.

96. The device of any of claims 87-95, wherein the projection screen further comprises a first clear region.

97. The device of claim 96, wherein the first clear region is transparent or comprises 15% clear plastic.

98. The device of claim 96 or 97, wherein the first clear region comprises an arc disposed at a bottom portion of the projection screen.

99. The device of any of claims 96-98, further comprising a second region that is translucent or transparent and is disposed about a periphery of the projection screen.

100. The device of claim 96, wherein the first clear region is disposed about a periphery of the projection screen.

101. The device of claim 100, wherein the projection screen further comprises a second clear region disposed at a bottom portion of the projection screen.

102. The device of any of claims 87-101, wherein the projection screen comprises a laminate having at least two layers.

103. The device of claim 102, wherein at least one of the layers comprises a reflective surface.

104. The device of claims 102 or 103, wherein at least one of the layers comprises a holographic material.

105. The device of any of claims 87-103, wherein at least a portion of the outer surface comprises a holographic material.

106. The device of claims 104 or 105, wherein the holographic material comprises an image of a flame.

107. The device of claims 104 or 105, wherein the holographic material comprises a plurality of colors.

108. The device of any of claims 104-107, wherein the set of light sources are configured to emit light onto the holographic material.

109. The device of any of claims 87-108, wherein the set of light sources comprises first, second, and third lights, each of which emits a predominant color of light that is different from the other lights.

110. The device of claim 109, wherein the first, second, and third lights emit orange light, white light and blue light, respectively.

111. The device of claim 109 or 110, wherein the set of light sources each emit light on to a face of the projection screen.

112. The device of any of claims 109-111, wherein the projection screen comprises a central axis that bisects the projection screen vertically, and wherein each of the first, second, and third lights is disposed within the housing such that a focal point of each of the first, second, and third lights is at the central axis of the projection screen at rest.

113. The device of any of claims 87-112, wherein the projection screen is affixed to the housing.

114. The device of any of claims 87-113, wherein the projection screen is pivotally coupled to the housing.

115. The device of claim 114, further comprising a coil of wire and a signal generator providing time-varying current to the coil to create a time-varying electromagnetic field, and wherein the projection screen comprises a magnet, and wherein the coil is disposed within the housing with respect to the magnet such that the electromagnetic field causes movement of the projection screen.

116. The device of claim 114, further comprising a fan, and wherein the fan is disposed within the housing with respect to the projection screen such that an airflow from the fan causes movement of the projection screen.

117. An electric lighting device configured to simulate an appearance of a flame, comprising:
a candle-shaped housing;
a memory configured to store one or more media files;
a video screen extending from the housing and having an on state and an off state; and
a microprocessor configured to present the one or more media files on the video screen.

118. The device of claim 117, wherein the video screen is shaped to resemble a candle flame.

119. The device of claim 117 or 118, wherein the video screen includes a clear periphery composed of plastic.

120. The device of any of claims 117-119, wherein the video screen has a concave surface.

121. The device of any of claims 117-120, wherein the video screen is transparent when in the off state.

122. The device of any of claims 117-120, wherein the video screen is translucent when in the off state.

123. The device of any of claims 117-122, wherein the video screen has a surface area of no more than 9 cm².

124. The device of any of claims 117-123, further comprising a wireless transceiver configured to receive a command signal, and wherein the microprocessor is configured to control the video screen as a function of the command signal.

125. The device of claim 124, wherein the command signal comprises an instruction to change the video screen to the on state.

126. The device of claim 124, wherein the command signal comprises an instruction to change the video screen to the off state.

127. The device of claim 124, wherein the command signal comprises an instruction to play a specific media file stored in the memory.

128. The device of any of claims 117-127, further comprising a wireless transceiver configured to receive a media file.

129. An electric lighting device configured to simulate an appearance of a flame, comprising:
a housing;
a memory configured to store one or more media files;
a video screen extending from the housing and having an on state and an off state; and
a microprocessor configured to present the one or more media files on the video screen.

130. The device of claim 129, wherein the video screen is embedded within a plastic projection screen.

131. The device of claim 130, further comprising wiring coupling the video screen to the microprocessor, and wherein the projection screen comprises a laminate having two or more layers between which the wiring is disposed.

132. The device of claim 130, wherein the microprocessor is disposed apart from the projection screen.

133. The device of claim 130, wherein the projection screen is pivotally coupled to the housing.

134. The device of any of claims 130-133, wherein the projection screen is rotatably coupled to the housing.

135. The device of any of claims 130-134, further comprising a drive mechanism configured to cause movement of the video screen with respect to the housing.

136. The device of claim 135, wherein the drive mechanism comprises an electromagnet, and wherein the projection screen comprises a magnet, and wherein the projection screen moves with respect to the housing as the magnet interacts with a magnetic field generated by the electromagnet.

137. The device of claim 135, wherein the drive mechanism comprises a fan, and wherein the projection screen moves with respect to the housing as air flow from the fan impinges on the projection screen.

138. The device of claim 135, wherein the drive mechanism comprises a motor that indirectly or directly drives movement of the projection screen.

139. The device of any of claims 129-138, wherein the projection screen comprises a memory, a microchip, and a battery.

140. The device of any of claims 129-138, further comprising:

a first induction coil;

wherein the projection screen comprises a memory, a microchip, and a second induction coil; and

wherein the second induction coil is disposed with respect to the first induction coil to create an inductive coupling between the coils.

141. The device of claim 140, wherein the projection screen comprises a battery that is wirelessly charged from energy received from the first induction coil via the second induction coil.

142. The device of claim 140 or 141, wherein the projection screen has an hourglass shape with upper and lower portions, and wherein the video screen is disposed in the upper portion, and wherein the second induction coil is disposed within the lower portion, and wherein the lower portion is disposed within the housing.

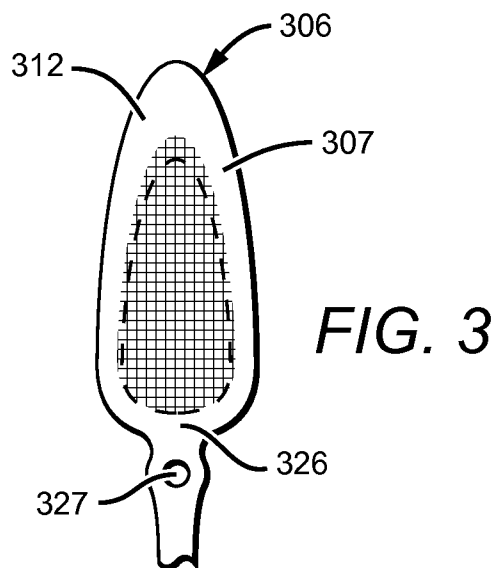
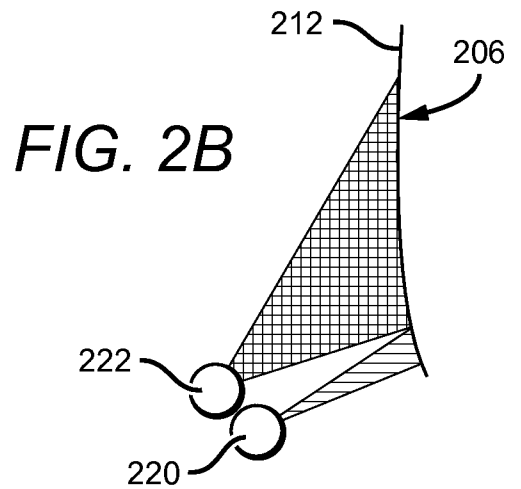
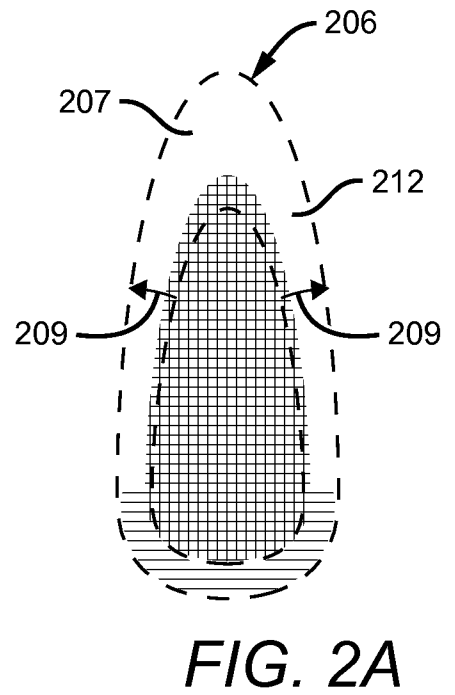
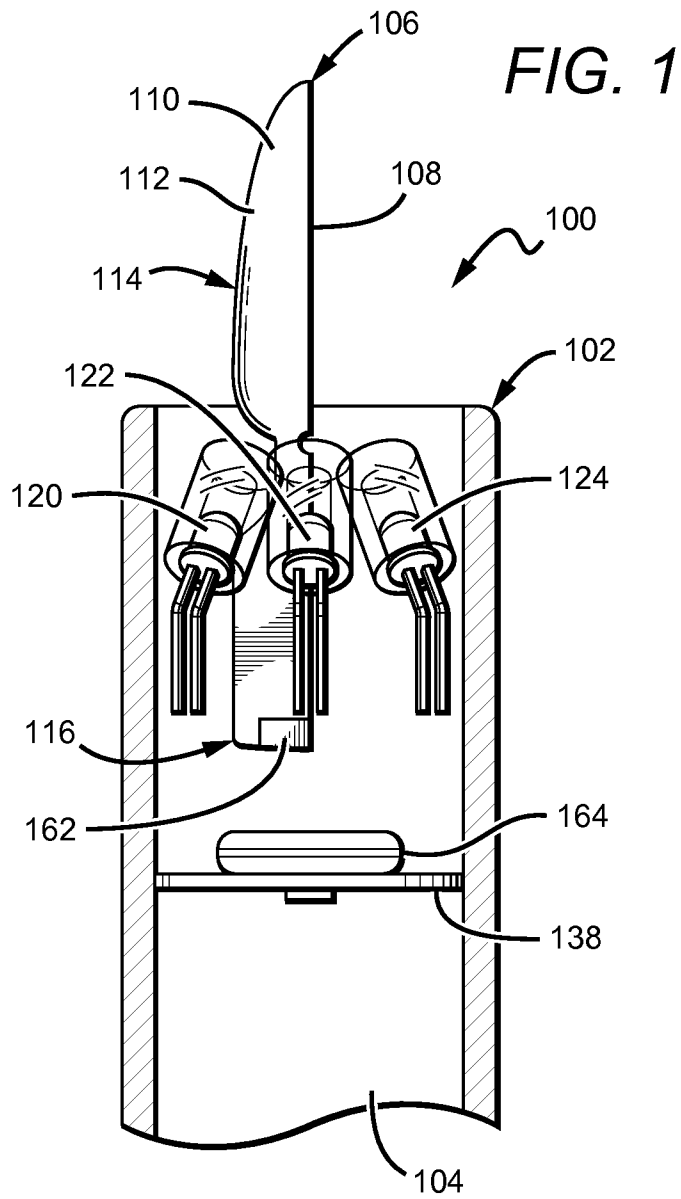

FIG. 4

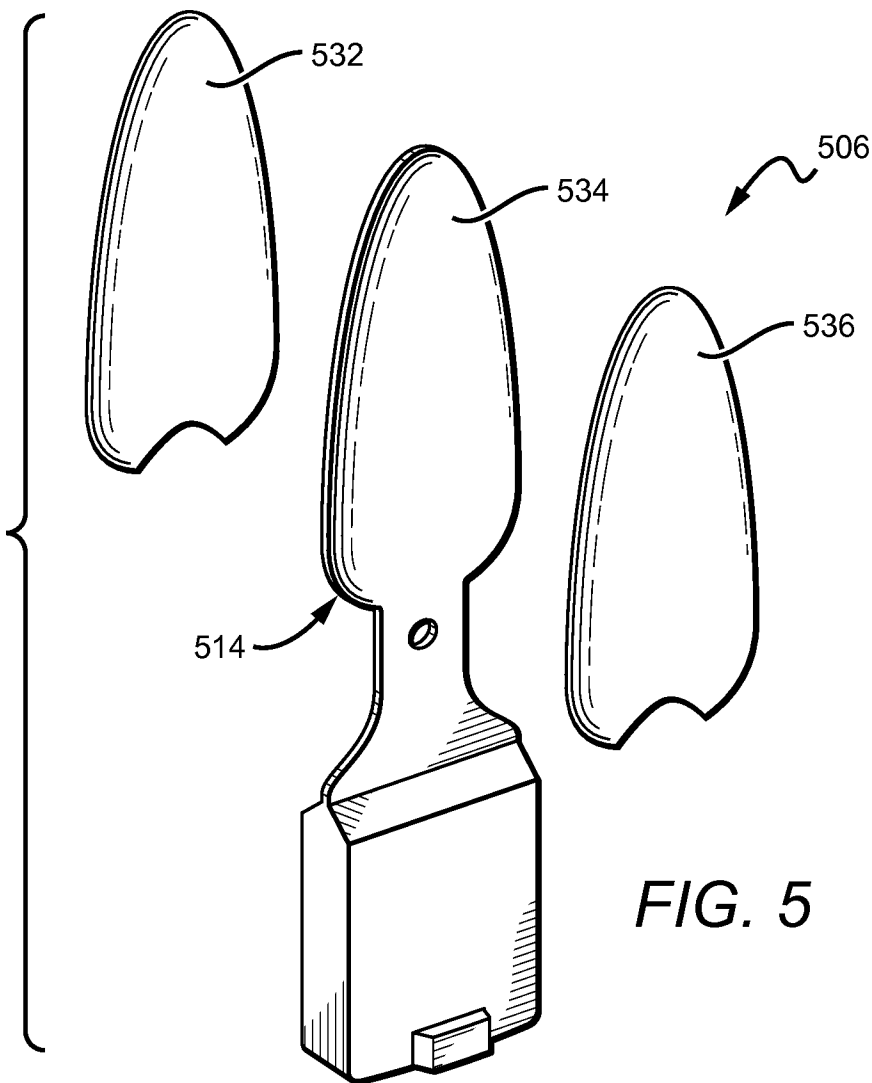
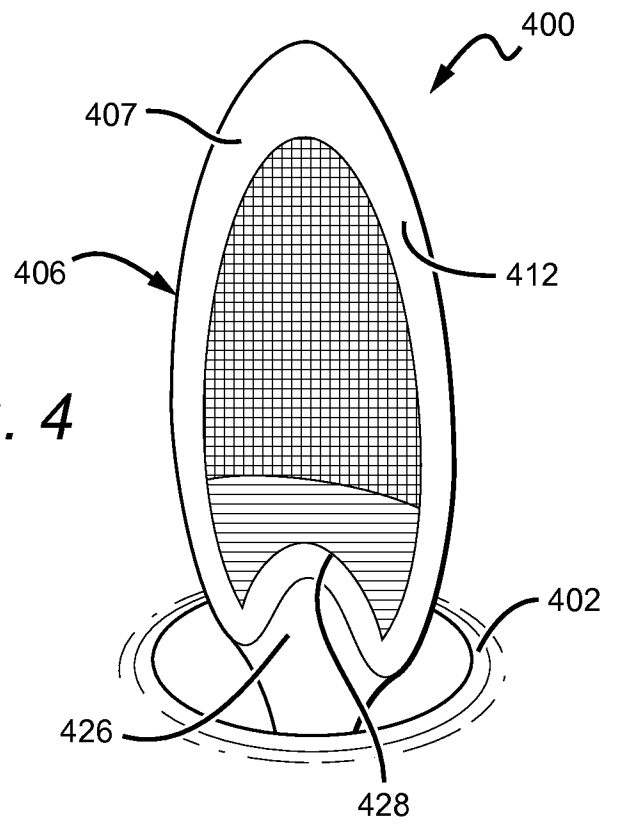

FIG. 5

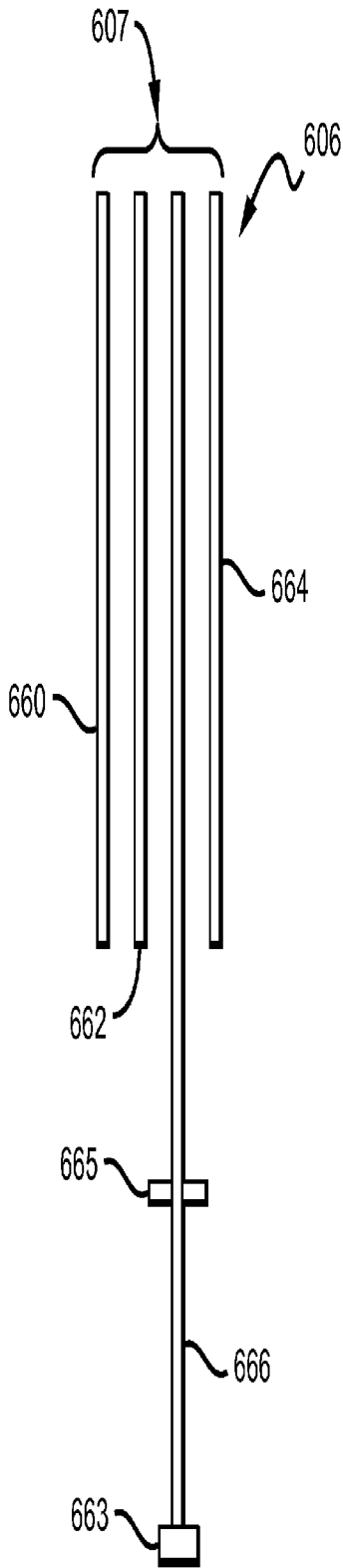

FIG. 6A

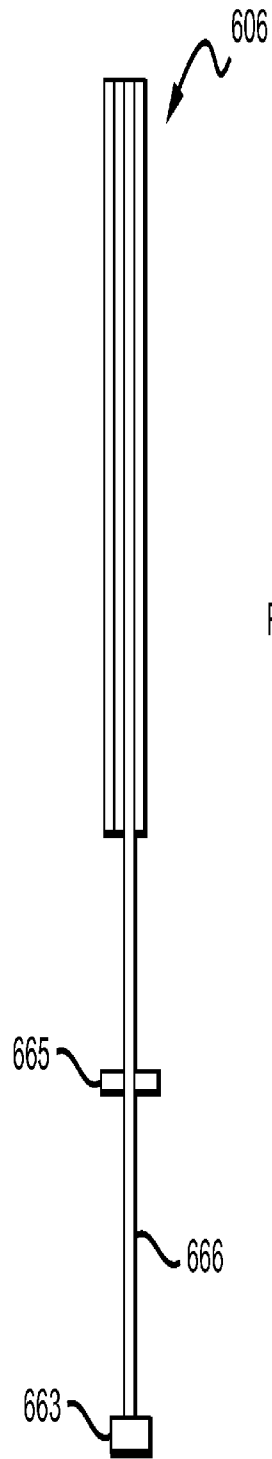

FIG. 6B

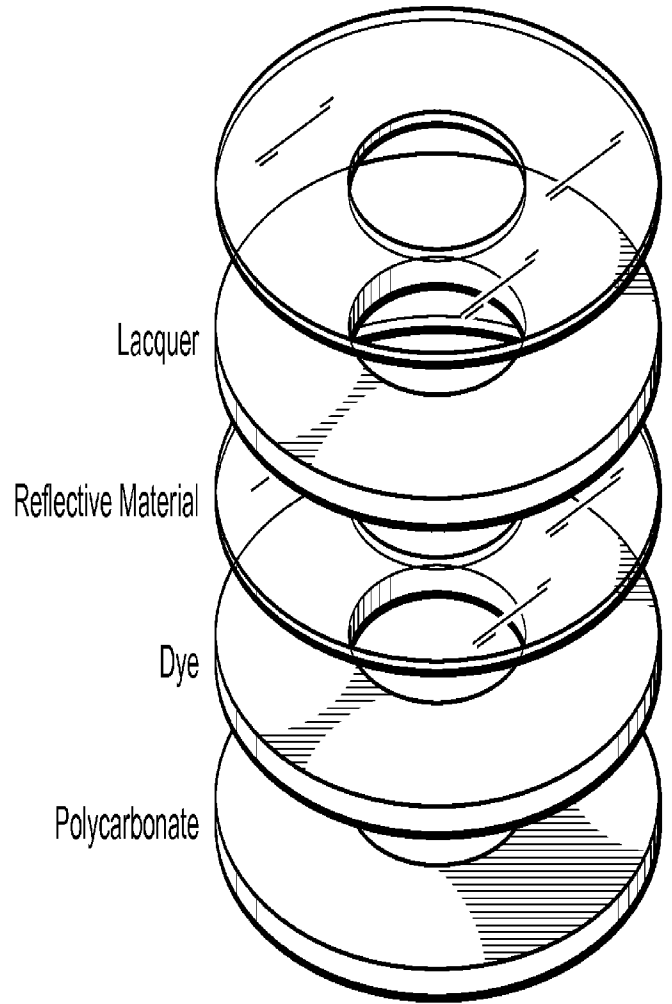

FIG. 7

FIG. 8

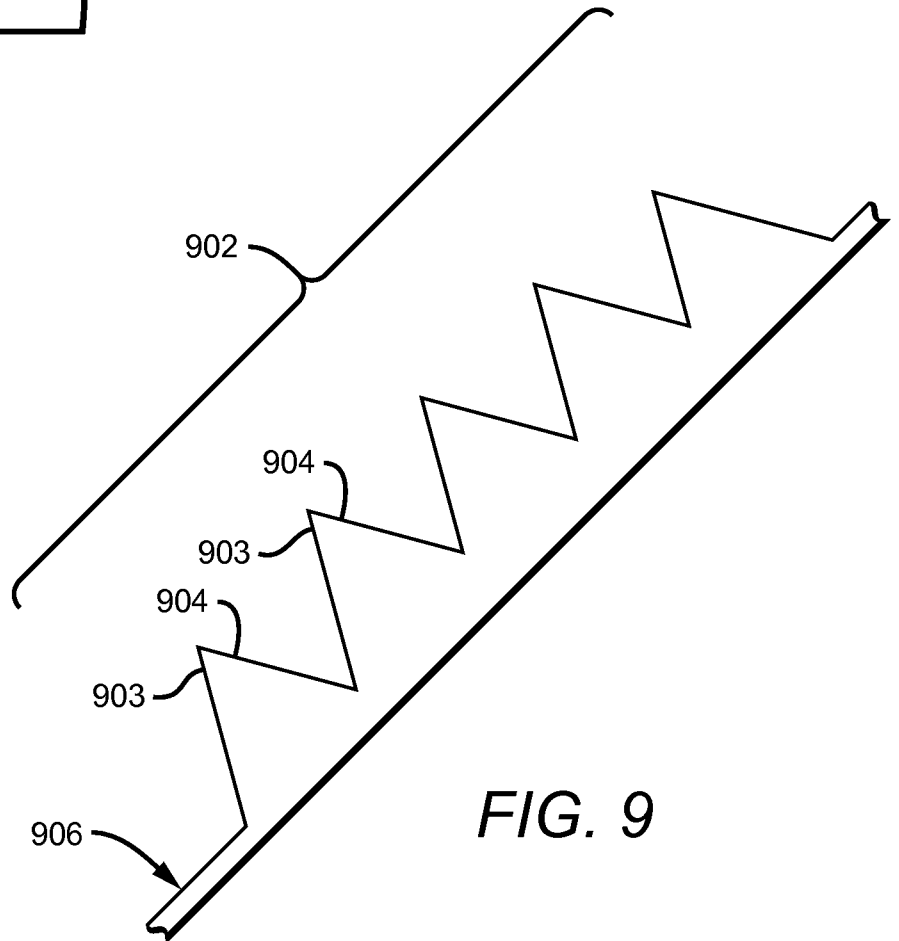
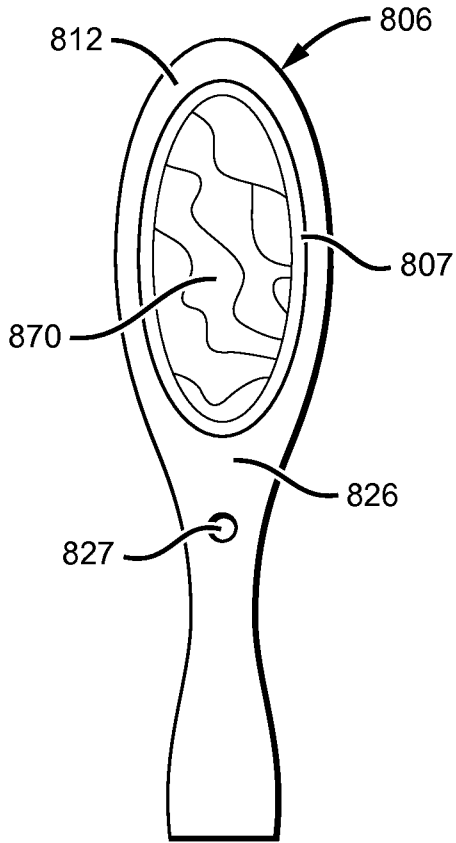

FIG. 9

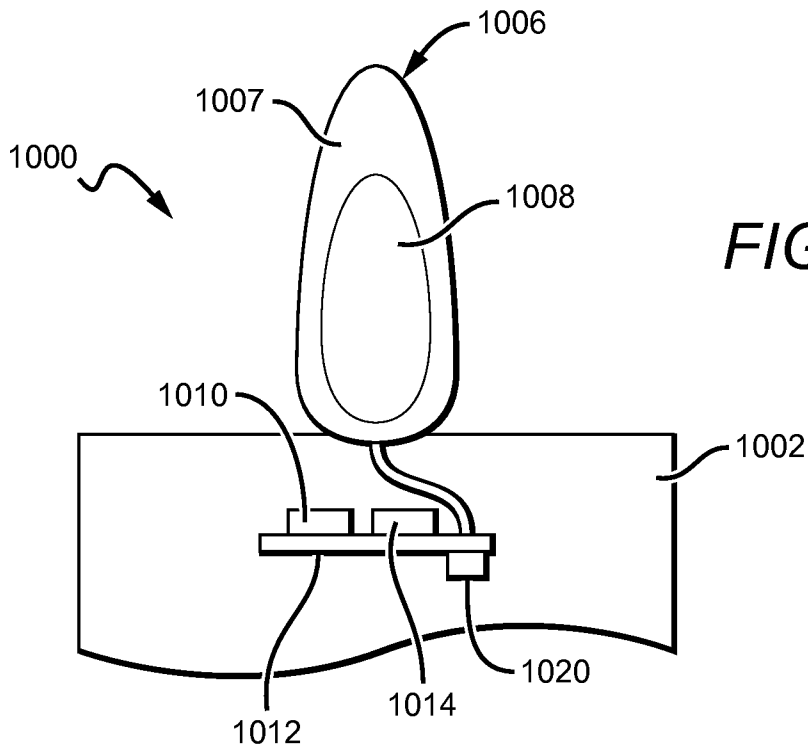

FIG. 10

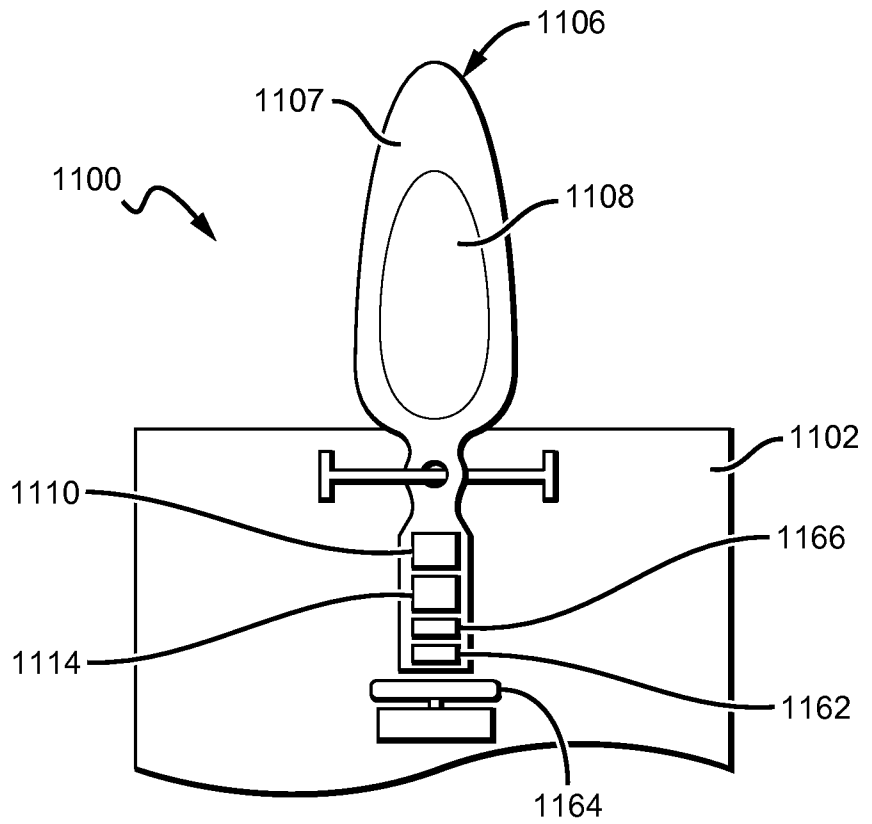

FIG. 11

A. CLASSIFICATION OF SUBJECT MATTER**F21S 10/04(2006.01)i**

According to International Patent Classification (IPC) or to both national classification and IPC

B. FIELDS SEARCHED

Minimum documentation searched (classification system followed by classification symbols)

F21S 10/04; F21V 33/00; A61L 9/14; F21Y 101/02; F21V 15/00; F21V 21/14; F21V 35/00; A61L 9/12

Documentation searched other than minimum documentation to the extent that such documents are included in the fields searched

Korean utility models and applications for utility models

Japanese utility models and applications for utility models

Electronic data base consulted during the international search (name of data base and, where practicable, search terms used)

eKOMPASS(KIPO internal) & Keywords: electric lighting, flame, housing, projection screen, transparent and light source

C. DOCUMENTS CONSIDERED TO BE RELEVANT

Category*	Citation of document, with indication, where appropriate, of the relevant passages	Relevant to claim No.
X	US 2006-0034100 A1 (GARY SCHNUCKLE et al.) 16 February 2006 See paragraphs [0036]-[0056], [0066]; claims 1-5; and figure 2.	1-2,9-12,43-46
Y		3,47-48,87,117-119
A		,129-134 88-91
Y	US 2012-0134157 A1 (XIAOFENG LI) 31 May 2012 See paragraphs [0027]-[0046]; claims 1-10; and figures 1-9.	3,47-48,87
Y	US 2007-0177394 A1 (CURTIS A. VOCK et al.) 02 August 2007 See paragraphs [0015]-[0024]; claims 1-7; and figures 1-7.	117-119,129-134
A	JP 2012-504310 A (DISNEY ENTERPRISES INC.) 16 February 2012 See paragraphs [0007]-[0011], [0014]-[0017], claim 1 and figure 1.	1-3,9-12,43-48 ,87-91,117-119 ,129-134
A	KR 10-2012-0098933 A (S.C. JOHNSON & SON, INC.) 05 September 2012 See paragraphs [0008]-[0010], [0022]-[0030], claim 1 and figures 1-4.	1-3,9-12,43-48 ,87-91,117-119 ,129-134

 Further documents are listed in the continuation of Box C. See patent family annex.

* Special categories of cited documents:

"A" document defining the general state of the art which is not considered to be of particular relevance

"E" earlier application or patent but published on or after the international filing date

"L" document which may throw doubts on priority claim(s) or which is cited to establish the publication date of another citation or other special reason (as specified)

"O" document referring to an oral disclosure, use, exhibition or other means

"P" document published prior to the international filing date but later than the priority date claimed

"T" later document published after the international filing date or priority date and not in conflict with the application but cited to understand the principle or theory underlying the invention

"X" document of particular relevance; the claimed invention cannot be considered novel or cannot be considered to involve an inventive step when the document is taken alone

"Y" document of particular relevance; the claimed invention cannot be considered to involve an inventive step when the document is combined with one or more other such documents, such combination being obvious to a person skilled in the art

"&" document member of the same patent family

Date of the actual completion of the international search

23 May 2014 (23.05.2014)

Date of mailing of the international search report

23 May 2014 (23.05.2014)

Name and mailing address of the ISA/KR

 International Application Division
 Korean Intellectual Property Office
 189 Cheongsu-ro, Seo-gu, Daejeon Metropolitan City, 302-701,
 Republic of Korea

Facsimile No. +82-42-472-7140

Authorized officer

KIM, Do Weon

Telephone No. +82-42-481-5560



Supplement Box

Continued on Box No. II

2. Claims Nos.: 6-8, 14, 16, 25, 27, 30, 35, 37, 40-42, 50-53, 55, 58, 66, 68, 71, 76, 78-80, 84-86, 97, 100-101, 103, 110, 115-116, 125-127, 136-138 and 141

3. Claims Nos.: 4-5, 13, 15, 17-24, 26, 28-29, 31-34, 36, 38-39, 49, 54, 56-57, 59-65, 67, 69-70, 72-75, 77, 81-83, 92-96, 98-99, 102, 104-109, 111-114, 120-124, 128, 135, 139-140 and 142

INTERNATIONAL SEARCH REPORT

Information on patent family members

International application No.

PCT/US2014/013923

Patent document cited in search report	Publication date	Patent family member(s)	Publication date
US 2006-0034100 A1	16/02/2006	US 2006-0034079 A1 US 7159994 B2 US 7261455 B2 WO 2006-020839 A2 WO 2006-020839 A3	16/02/2006 09/01/2007 28/08/2007 23/02/2006 15/06/2006
US 2012-0134157 A1	31/05/2012	CA 2779978 A1 CN 101865413 A CN 101865413 B EP 2587127 A1 WO 2012-000418 A1	05/01/2012 20/10/2010 01/08/2012 01/05/2013 05/01/2012
US 2007-0177394 A1	02/08/2007	None	
JP 2012-504310 A	16/02/2012	CA 2772728 A1 CA 2772728 C CN 101918755 A CN 101918755 B CN 103047604 A EP 2232128 A1 EP 2232128 B1 EP 2546571 A1 JP 05399499 B2 US 2010-0079999 A1 US 2011-0019422 A1 US 2011-0110073 A1 US 2011-0127914 A1 US 7837355 B2 US 8070319 B2 US 8132936 B2 US 8342712 B2 WO 2010-039347 A1	08/04/2010 19/02/2013 15/12/2010 29/08/2012 17/04/2013 29/09/2010 20/02/2013 16/01/2013 29/01/2014 01/04/2010 27/01/2011 12/05/2011 02/06/2011 23/11/2010 06/12/2011 13/03/2012 01/01/2013 08/04/2010
KR 10-2012-0098933 A	05/09/2012	AU 2003-233542 A1 AU 2003-233542 B2 AU 2003-291510 A1 AU 2003-291510 B2 AU 2004-212459 A1 AU 2004-212459 B2 AU 2005-210645 A1 AU 2005-210645 B2 AU 2005-210656 A1 AU 2005-284935 A1 AU 2005-284935 B2 AU 2005-285076 A1 AU 2005-285076 B2 AU 2005-285102 A1 AU 2005-285102 B2 AU 2005-295822 A1	02/12/2003 05/03/2009 03/06/2004 28/05/2009 26/08/2004 11/03/2010 18/08/2005 24/06/2010 18/08/2005 23/03/2006 23/12/2010 23/03/2006 30/04/2009 23/03/2006 29/04/2010 27/04/2006

INTERNATIONAL SEARCH REPORT

Information on patent family members

International application No.

PCT/US2014/013923

Patent document cited in search report	Publication date	Patent family member(s)	Publication date
		AU 2005-295822 B2	20/01/2011
		AU 2006-230472 A1	05/10/2006
		AU 2006-235470 A1	19/10/2006
		AU 2006-235470 B2	06/01/2011
		AU 2006-235545 A1	19/10/2006
		AU 2006-235545 B2	20/05/2010
		AU 2006-252775 A1	07/12/2006
		AU 2006-252775 B2	07/04/2011
		AU 2006-269841 A1	25/01/2007
		AU 2006-269841 B2	28/07/2011
		AU 2006-269911 A1	25/01/2007
		AU 2006-269911 B2	04/03/2010
		AU 2006-269912 A1	25/01/2007
		AU 2006-269912 B2	28/07/2011
		AU 2006-270068 A1	25/01/2007
		AU 2006-270068 B2	24/02/2011
		AU 2006-279042 A1	15/02/2007
		AU 2006-279996 A1	22/02/2007
		AU 2006-279996 B2	16/12/2010
		AU 2006-311878 A1	18/05/2007
		AU 2006-311906 A1	18/05/2007
		AU 2006-312004 A1	18/05/2007
		AU 2006-312004 B2	09/09/2010
		AU 2006-331866 A1	05/07/2007
		AU 2006-331898 A1	05/07/2007
		AU 2007-269928 A1	10/01/2008
		AU 2007-284642 A1	21/02/2008
		AU 2007-332807 A1	19/06/2008
		AU 2008-227110 A1	25/09/2008
		AU 2008-227110 B2	20/10/2011
		CA 2483684 A1	27/11/2003
		CA 2483684 C	06/07/2010
		CA 2496947 A1	17/08/2005
		CA 2496947 C	23/09/2008
		CA 2515250 A1	26/08/2004
		CA 2515250 C	23/09/2008
		CA 2517583 A1	27/05/2004
		CA 2517583 C	19/02/2008
		CA 2555028 A1	18/08/2005
		CA 2555028 C	27/10/2009
		CA 2555031 A1	18/08/2005
		CA 2555031 C	02/02/2010
		CA 2578860 A1	23/03/2006
		CA 2578860 C	12/07/2011
		CA 2579098 A1	23/03/2006
		CA 2579098 C	09/02/2010
		CA 2579110 A1	23/03/2006
		CA 2579110 C	09/02/2010
		CA 2583628 A1	27/04/2006
		CA 2583628 C	13/09/2011

INTERNATIONAL SEARCH REPORT

Information on patent family members

International application No.

PCT/US2014/013923

Patent document cited in search report	Publication date	Patent family member(s)	Publication date
		CA 2596555 A1	07/12/2006
		CA 2603622 A1	05/10/2006
		CA 2603622 C	18/01/2011
		CA 2604347 A1	19/10/2006
		CA 2604347 C	18/01/2011
		CA 2604350 A1	19/10/2006
		CA 2609305 A1	07/12/2006
		CA 2615175 A1	25/01/2007
		CA 2615175 C	04/01/2011
		CA 2615498 A1	25/01/2007
		CA 2615498 C	04/01/2011
		CA 2615499 A1	25/01/2007
		CA 2615499 C	19/10/2010
		CA 2615502 A1	25/01/2007
		CA 2615502 C	03/01/2012
		CA 2617956 A1	22/02/2007
		CA 2617956 C	05/04/2011
		CA 2617988 A1	15/02/2007
		CA 2617988 C	15/02/2011
		CA 2624694 A1	05/07/2007
		CA 2624708 A1	12/04/2007
		CA 2626471 A1	18/05/2007
		CA 2626476 A1	18/05/2007
		CA 2627805 A1	18/05/2007
		CA 2627805 C	24/05/2011
		CA 2630819 A1	07/06/2007
		CA 2634253 A1	05/07/2007
		CA 2634253 C	18/10/2011
		CA 2647897 A1	25/10/2007
		CA 2647897 C	24/01/2012
		CA 2680448 A1	25/09/2008
		CA 2680448 C	17/01/2012
		CA 2683181 A1	27/04/2006
		CA 2733808 A1	12/04/2007
		CA 2733808 C	15/05/2012
		CN 100577215 C	06/01/2010
		CN 101065299 A	31/10/2007
		CN 101065299 B	23/05/2012
		CN 101160140 A	09/04/2008
		CN 101160140 B	29/08/2012
		CN 101313177 A	26/11/2008
		CN 101313177 B	21/12/2011
		CN 101322056 A	10/12/2008
		CN 101466480 A	24/06/2009
		CN 101678948 A	24/03/2010
		CN 101678948 B	29/08/2012
		CN 101954110 A	26/01/2011
		CN 102616480 A	01/08/2012
		CN 1195451 C	06/04/2005
		CN 1352537 A	05/06/2002

INTERNATIONAL SEARCH REPORT

Information on patent family members

International application No.

PCT/US2014/013923

Patent document cited in search report	Publication date	Patent family member(s)	Publication date
		CN 1666573 C	07/09/2005
		CN 1820543 A	16/08/2006
		CN 1820543 B	17/11/2010
		CN 1929874 A	14/03/2007
		EP 1158900 A1	05/12/2001
		EP 1512312 A1	09/03/2005
		EP 1564485 A2	17/08/2005
		EP 1564485 A3	05/03/2014
		EP 1574827 A1	14/09/2005
		EP 1608584 A2	28/12/2005
		EP 1631325 A1	08/03/2006
		EP 1631325 B1	19/01/2011
		EP 1708761 A1	11/10/2006
		EP 1729827 A1	13/12/2006
		EP 1792121 A1	06/06/2007
		EP 1792121 B1	11/04/2012
		EP 1794498 A2	13/06/2007
		EP 1797367 A1	20/06/2007
		EP 1797367 B1	26/05/2010
		EP 1807322 A2	18/07/2007
		EP 1807322 B1	09/01/2008
		EP 1832526 A2	12/09/2007
		EP 1832526 A3	26/09/2007
		EP 1832526 B1	31/12/2008
		EP 1832527 A2	12/09/2007
		EP 1832527 A3	26/09/2007
		EP 1832527 B1	10/12/2008
		EP 1863542 A1	12/12/2007
		EP 1868733 A1	26/12/2007
		EP 1878449 A1	16/01/2008
		EP 1885406 A2	13/02/2008
		EP 1888256 A1	20/02/2008
		EP 1888256 B1	07/07/2010
		EP 1888968 A1	20/02/2008
		EP 1904790 A1	02/04/2008
		EP 1904790 B1	09/09/2009
		EP 1907521 A1	09/04/2008
		EP 1907521 B1	03/06/2009
		EP 1907522 A1	09/04/2008
		EP 1907522 B1	30/06/2010
		EP 1907753 A1	09/04/2008
		EP 1915570 A1	30/04/2008
		EP 1920036 A1	14/05/2008
		EP 1920036 B1	30/06/2010
		EP 1941308 A1	09/07/2008
		EP 1941308 B1	10/07/2013
		EP 1948998 A1	30/07/2008
		EP 1948998 B1	22/07/2009
		EP 1949150 A2	30/07/2008
		EP 1952059 A1	06/08/2008

INTERNATIONAL SEARCH REPORT

Information on patent family members

International application No.

PCT/US2014/013923

Patent document cited in search report	Publication date	Patent family member(s)	Publication date
		EP 1952059 B1	15/07/2009
		EP 1969288 A1	17/09/2008
		EP 1971802 A2	24/09/2008
		EP 1977163 A1	08/10/2008
		EP 1977163 B1	09/02/2011
		EP 2004334 A1	24/12/2008
		EP 2032178 A1	11/03/2009
		EP 2032178 B1	04/08/2010
		EP 2054167 A2	06/05/2009
		EP 2079647 A2	22/07/2009
		EP 2092234 A2	26/08/2009
		EP 2099502 A1	16/09/2009
		EP 2099502 B1	03/03/2010
		EP 2384771 A1	09/11/2011
		EP 2384771 B1	23/01/2013
		EP 2465791 A2	20/06/2012
		JP 04762246 B2	31/08/2011
		JP 04847347 B2	28/12/2011
		JP 04912408 B2	11/04/2012
		JP 04913127 B2	11/04/2012
		JP 04954984 B2	20/06/2012
		JP 05079003 B2	21/11/2012
		JP 05235192 B2	10/07/2013
		JP 05336355 B2	06/11/2013
		JP 2001-187046 A	10/07/2001
		JP 2005-525897 A	02/09/2005
		JP 2007-520870 A	26/07/2007
		JP 2007-527101 A	20/09/2007
		JP 2008-515738 A	15/05/2008
		JP 2008-538310 A	23/10/2008
		JP 2008-538693 A	06/11/2008
		JP 2008-542135 A	27/11/2008
		JP 2009-515299 A	09/04/2009
		JP 2009-521073 A	28/05/2009
		JP 2009-521784 A	04/06/2009
		JP 2009-521785 A	04/06/2009
		JP 2009-533216 A	17/09/2009
		JP 2009-542322 A	03/12/2009
		JP 2010-500865 A	07/01/2010
		JP 2010-512179 A	22/04/2010
		JP 2010-522080 A	01/07/2010