



(51) International Patent Classification:

F23C 9/00 (2006.01) F23M 5/02 (2006.01)
F23D 14/08 (2006.01) F23C 5/00 (2006.01)
F23D 14/70 (2006.01)

(21) International Application Number:

PCT/US2016/066463

(22) International Filing Date:

14 December 2016 (14.12.2016)

(25) Filing Language:

English

(26) Publication Language:

English

(30) Priority Data:

62/316,246 31 March 2016 (31.03.2016) US
16170266.7 19 May 2016 (19.05.2016) EP

(71) Applicant: **EXXONMOBIL CHEMICAL PATENT INC.** [US/US]; 5200 Bayway Drive, Baytown, TX 77520 (US).

(72) Inventors: **STEPHENS, George**; 27527 Fairway Oaks Drive, Huffman, TX 77336 (US). **SPICER, David, B.**; 5319 Del Monte Drive, Houston, TX 77056 (US).

(74) Agents: **HINDMARSH, Brandon, J.** et al.; ExxonMobil Chemical Company, Law Department, P.O. Box 2149, Baytown, TX 77522-2149 (US).

(81) Designated States (unless otherwise indicated, for every kind of national protection available): AE, AG, AL, AM, AO, AT, AU, AZ, BA, BB, BG, BH, BN, BR, BW, BY, BZ, CA, CH, CL, CN, CO, CR, CU, CZ, DE, DJ, DK, DM, DO, DZ, EC, EE, EG, ES, FI, GB, GD, GE, GH, GM, GT, HN, HR, HU, ID, IL, IN, IR, IS, JP, KE, KG, KH, KN, KP, KR, KW, KZ, LA, LC, LK, LR, LS, LU, LY, MA, MD, ME, MG, MK, MN, MW, MX, MY, MZ, NA, NG, NI, NO, NZ, OM, PA, PE, PG, PH, PL, PT, QA, RO, RS, RU, RW, SA, SC, SD, SE, SG, SK, SL, SM, ST, SV, SY, TH, TJ, TM, TN, TR, TT, TZ, UA, UG, US, UZ, VC, VN, ZA, ZM, ZW.

[Continued on next page]

(54) Title: BURNER, FURNACE, AND STEAM CRACKING PROCESSES USING THE SAME

FIG. 1

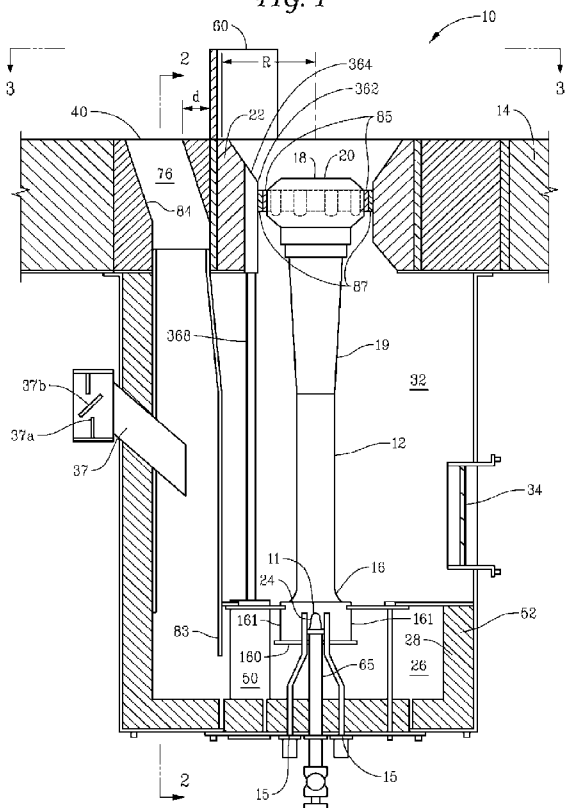

(57) Abstract: A burner sub-system, a furnace comprising the same, a fuel combustion process and steam cracking process carried out in the furnace. The burner sub-system comprises a barrier wall segment (60) between the burner tip (20) and the flue-gas recirculation ("FGR") duct (40), effectively blocking direct gas flow between the burner tip and the FGR duct opening, but without encircling the whole burner tip. The presence of the partial barrier wall has the advantage of preventing the temperature inside the FGR duct from becoming too high, while achieving low NOx emissions from the combustion process without overheating the burner tip because of reduced amount of heat reflection to the burner tip compared to an annular barrier wall. The invention is particularly useful in furnaces where hydrogen-rich fuel gas is combusted.

WO 2017/171942 A1

(84) Designated States (*unless otherwise indicated, for every kind of regional protection available*): ARIPO (BW, GH, GM, KE, LR, LS, MW, MZ, NA, RW, SD, SL, ST, SZ, TZ, UG, ZM, ZW), Eurasian (AM, AZ, BY, KG, KZ, RU, TJ, TM), European (AL, AT, BE, BG, CH, CY, CZ, DE, DK, EE, ES, FI, FR, GB, GR, HR, HU, IE, IS, IT, LT, LU, LV, MC, MK, MT, NL, NO, PL, PT, RO, RS, SE, SI, SK, SM, TR), OAPI (BF, BJ, CF, CG, CI, CM, GA, GN, GQ, GW, KM, ML, MR, NE, SN, TD, TG).

Declarations under Rule 4.17:

- *as to applicant's entitlement to apply for and be granted a patent (Rule 4.17(ii))*
- *as to the applicant's entitlement to claim the priority of the earlier application (Rule 4.17(iii))*

Published:

- *with international search report (Art. 21(3))*

BURNER, FURNACE, AND STEAM CRACKING PROCESSES USING THE SAME5 **PRIORITY**

[0001] This invention claims priority to and the benefit of U.S. Patent Application Serial No. 62/316,246, filed March 31, 2016, and European Patent Application No. 16170266.7 filed May 19, 2016, both of which are herein incorporated by reference.

TECHNICAL FIELD

10 [0002] This invention relates to burners, furnaces, fuel combustion processes using the same, and steam cracking processes using the same. In particular, it relates to burner sub-systems capable of burning fuel gas rich in hydrogen, furnaces comprising the same, hydrogen-rich fuel gas combustion processes using the same, and steam cracking processes using the same.

15 **BACKGROUND**

[0003] In gas fired industrial furnaces, NO_x is formed by the oxidation of nitrogen drawn into the burner with the combustion air stream. The formation of NO_x is widely believed to occur primarily in regions of the flame where there exist both high temperatures and an abundance of oxygen. Since ethylene furnaces are amongst the highest temperature furnaces used in the hydrocarbon processing industry, the natural tendency of burners in these furnaces
20 is to produce high levels of NO_x emissions.

[0004] The majority of recent low NO_x burners for gas-fired industrial furnaces are based on the use of multiple fuel jets in a single burner. Such burners may employ fuel staging, flue-gas recirculation ("FGR"), or a combination of both. U.S. Patent Nos. 5,098,282 and
25 6,007,325 disclose burners using a combination of fuel staging and flue-gas recirculation. Certain burners may have as many as 8-12 fuel nozzles in a single burner. The large number of fuel nozzles require the use of very small diameter nozzles. In addition, the fuel nozzles of such burners are generally exposed to the high temperature flue-gas in the firebox.

[0005] One technique for reducing NO_x that has become widely accepted in industry is
30 known as staging. With staging, the primary flame zone is deficient in either air (fuel-rich) or fuel (fuel-lean). The balance of the air or fuel is injected into the burner in a secondary flame zone or elsewhere in the combustion chamber. As is well known, a fuel-rich or fuel-lean combustion zone is less conducive to NO_x formation than an air-fuel fuel ratio closer to stoichiometry. Combustion staging results in reducing peak temperatures in the primary
35 flame zone and has been found to alter combustion speed in a way that reduces NO_x. Since NO_x formation is exponentially dependent on gas temperature, even small reductions in peak

5 flame temperature dramatically reduce NO_x emissions. However this is generally balanced with the fact that radiant heat transfer decreases with reduced flame temperature, while CO emissions, an indication of incomplete combustion, may actually increase.

[0006] In the context of premix burners, the term primary air refers to the air premixed with the fuel; secondary, and in some cases tertiary, air refers to the balance of the air
10 required for proper combustion. In raw gas burners, primary air is the air that is more closely associated with the fuel; secondary and tertiary air is more remotely associated with the fuel. The upper limit of flammability refers to the mixture containing the maximum fuel concentration (fuel-rich) through which a flame can propagate.

[0007] U.S. Patent No. 4,629,413 discloses a low NO_x premix burner and discusses the
15 advantages of premix burners and methods to reduce NO_x emissions. The premix burner of U.S. Patent No. 4,629,413 lowers NO_x emissions by delaying the mixing of secondary air with the flame and allowing some cooled flue gas to recirculate with the secondary air. The manner in which the burner disclosed achieves light off at start-up and its impact on NO_x emissions is not addressed. The contents of U.S. Patent No. 4,629,413 are incorporated
20 by reference in their entirety.

[0008] U.S. Patent No. 5,092,761 discloses a method and apparatus for reducing
NO_x emissions from premix burners by recirculating flue gas. Flue gas is drawn from the furnace through recycle ducts by the inspirating effect of fuel gas and combustion air passing through a venturi portion of a burner tube. Airflow into the primary air chamber is controlled
25 by dampers and, if the dampers are partially closed, the reduction in pressure in the chamber allows flue gas to be drawn from the furnace through the recycle ducts and into the primary air chamber. The flue gas then mixes with combustion air in the primary air chamber prior to combustion to dilute the concentration of oxygen in the combustion air, which lowers flame temperature and thereby reduces NO_x emissions. The flue-gas recirculating system may be
30 retrofitted into existing burners or may be incorporated in new low NO_x burners. The entire contents of U.S. Patent No. 5,092,761 are incorporated herein by reference.

[0009] A drawback of the system of U.S. Patent No. 5,092,761 is that the staged-air used to cool the FGR duct first enters the furnace firebox, traverse a short distance across the floor and then enter the FGR duct. During this passage, the staged air is exposed to radiation from
35 the hot flue-gas in the firebox. Analyses of experimental data from burner tests suggest that the staged-air may be as hot as 700° F when it enters the FGR duct.

[0010] From the standpoint of NO_x production, another drawback associated with the burner of U.S. Patent No. 5,092,761 relates to the configuration of the lighting chamber,

5 necessary for achieving burner light off. The design of this lighting chamber, while effective for achieving light off, has been found to be a localized source of high NO_x production during operation. Other burner designs possess a similar potential for localized high NO_x production, since similar configurations are known to exist for other burner designs, some of which have been described hereinabove.

10 [0011] Additionally, commercial experience and modeling have shown when flue-gas recirculation rates are raised, there is a tendency of the flame to be drawn into the FGR duct. Often, it is this phenomenon that constrains the amount of flue-gas recirculation. When the flame enters directly into the flue-gas recirculation duct, the temperature of the burner venturi tends to rise, which raises flame speed and causes the recirculated flue gas to be less effective
15 in reducing NO_x. From an operability perspective, the flue-gas recirculation rate needs to be lowered to keep the flame out of the FGR duct to preserve the life of the metallic FGR duct.

[0012] U.S. Patent No. 6,877,980 discloses a burner for use in furnaces such as those used in steam cracking with increased FGR recirculation rate and low NO_x formation. The burner includes a primary air chamber; a burner tube having an upstream end, a downstream
20 end and a venturi intermediate said upstream and downstream ends, said venturi including a throat portion having substantially constant internal cross-sectional dimensions such that the ratio of the length to maximum internal cross-sectional dimension of said throat portion is at least 3; a burner tip mounted on the downstream end of said burner tube adjacent a first floor burner opening in the furnace, so that combustion of the fuel takes place downstream of said
25 burner tip; and a fuel orifice located adjacent the upstream end of said burner tube, for introducing fuel into said burner tube. In the burner disclosed therein, a circular barrier wall is erected surrounding the floor burner opening, blocking the base of the floor burner flame from the flue-gas recirculation duct ports on the floor. The barrier wall serves the purpose of stabilizing the flame and reducing NO_x formation.

30 [0013] It has been recently found that, however, the annular barrier wall in the burner of U.S. Patent No. 6,877,980 also reflects the heat produced by the flame to the burner tip, thereby increasing the burner tip temperature. Where the fuel gas comprises primarily hydrocarbons such as methane, the burner tip temperature is generally reasonably low to provide a satisfactory life, even with the reflected heat from the barrier wall. However,
35 where the fuel gas comprises primarily hydrogen (i.e., comprising at least 50 mol% of hydrogen), the flame speed and flame temperature are significantly higher, and so is the amount of heat reflected by the barrier wall to the burner tip. As a result, the burner tip is

5 frequently overheated to an exceedingly high temperature, leading to premature failure, especially during burner turn-down process or flame flash-back.

[0014] Therefore, there is a need for an improved burner sub-system design with reduced overheating potential, especially when hydrogen-rich fuel gas is used. The present invention satisfies this and other needs.

10 **SUMMARY**

[0015] It has been found that, by employing a barrier wall segment between the floor burner opening and the FGR duct opening capable of blocking direct gas flow between these two, in whole or in part, instead of a annular barrier wall surrounding the entirety of the floor burner opening, one can effectively reduce the amount of heat reflected to the burner tip, 15 resulting in a lower burner tip temperature enabling satisfactory life thereof, even when hydrogen-rich fuel gas is used. A burner sub-system including such barrier segment can achieve a high level of FGR rate, a relatively low temperature inside the FGR, a low level of NO_x emissions, without decreasing flame stability. Such a burner sub-system can be advantageously used in hydrocarbon steam cracking furnaces.

20 [0016] Thus, a first aspect of the present invention relates to burner sub-system comprising: (a1) a furnace floor segment having a floor burner opening and a flue-gas recirculation duct opening; (a2) a tile enclosure lining the periphery of the floor burner opening; (a3) a burner comprising a burner tip adjacent and surrounded by the floor burner opening, the burner tip configured to provide a floor burner flame through the floor burner 25 opening and having a vertical centerline; (a4) a flue-gas recirculation duct opening adjacent the tile enclosure; and (a5) a barrier wall segment extending upwards from the upper surface of the furnace floor segment between the flue-gas recirculation duct opening and the burner tip, the barrier wall segment having an angle of view no greater than 180° when viewed from the point where the vertical centerline of the burner tip intercepts a plane of the furnace floor 30 segment.

[0017] A second aspect of the present invention relates to a furnace comprising: (b1) at least one burner sub-system according to the first aspect of the present invention; (b2) a furnace floor comprising each of the furnace floor segment of the at least one burner sub-system; and (b3) one or more furnace side walls; wherein the furnace floor and the one or 35 more furnace side walls form a furnace fire box.

[0018] A third aspect of the present invention relates to a fuel combustion process carried out in a furnace according to the second aspect of the present invention, the process comprising: (c1) supplying a fuel gas comprising at least 50 mol% of hydrogen into the at

5 least one burner sub-system; and (c2) combusting the fuel gas to form a floor burner flame above the burner tip inside the furnace fire box.

[0019] A fourth aspect of the present invention relates to a steam cracking process comprising a fuel combustion process of the third aspect of the present invention, wherein a reactant stream comprising a hydrocarbon is heated inside a cracking tube which is heated
10 inside the furnace by the flame.

[0020] These and other features of the present invention will be apparent from the detailed description taken with reference to accompanying drawings.

BRIEF DESCRIPTION OF THE DRAWINGS

[0021] The invention is further explained in the description that follows with reference to
15 the drawings illustrating, by way of non-limiting examples, various embodiments of the invention wherein:

Fig. 1 illustrates an elevation partly in section of an example of the burner sub-system of the present invention;

Fig. 2 is an elevation partly in section taken along line 2—2 of Fig. 1;

20 Fig. 3 is a plan view taken along line 3—3 of Fig. 1;

Fig. 4 is a perspective view of a specific example of a flue-gas recirculation duct useful in the burner sub-system in accordance with the present invention;

Fig. 5 is a top plan view of a centering plate useful in an example of the burner sub-system of the present invention;

25 Fig. 6A is a cross-sectional view of a fuel spud useful in an example of the burner sub-system of the present invention;

Fig. 6B is a cross-sectional view of another example of an improved fuel spud useful in an example of the burner sub-system of the present invention;

30 Fig. 7A and Fig. 7B are sectional views comparing, respectively the venturi of a conventional burner tube with the venturi of a burner tube particularly useful in an example of the burner sub-system of the present invention;

Fig. 8 is a perspective view of a burner tip useful in an example of the burner sub-system of the present invention;

35 Figs. 9A and 9B are plan views of the tip of a burner particularly useful in an example of the present invention and the tip of another, conventional burner, respectively;

Fig. 10A is an exploded view of a burner tip seal useful in an example of the burner sub-system of the present invention;

5 Fig. 10B is an exploded view of another burner tip seal useful in an example of the burner sub-system of the present invention;

Fig. 10C is an exploded view of yet another burner tip seal useful in an example of the burner sub-system of the present invention;

10 Fig. 11 illustrates an example of a seal means for sealing in the region of the pilot chamber useful in an example of the burner sub-system of the present invention;

Fig. 12 is a perspective view of a barrier wall segment in accordance with one example of the burner sub-system of present invention; and

Fig. 12A is a perspective view of an annular barrier wall in the prior art.

15 [0022] Fig. 13 is a schematic illustration showing an example of a furnace of the present invention comprising multiple side wall burners mounted on side walls.

[0023] Fig. 14 is a schematic illustration showing an example of a furnace of the present invention without a side wall burner mounted on side walls.

[0024] Fig. 15 is a plan view of an example of a furnace of the present invention without a separation wall between adjacent rows of burners.

20 **DETAILED DESCRIPTION**

[0025] Although the present invention is described in terms of a burner sub-system for use in connection with a furnace or an industrial furnace, it will be apparent to one of skill in the art that the teachings of the present invention also have applicability to other process components such as, for example, boilers. Thus, the term furnace herein shall be understood
25 to mean furnaces, boilers and other applicable process components.

[0026] As used herein, a "hydrogen-rich" gas is a gas comprising at least 50 mol% of molecular hydrogen. Hydrogen-rich fuel gas comprising at least 50, 55, 60, 65, 70, 75, 80, 85, 90, 95, 98, or even 99 mol% of molecular hydrogen has become more readily available than before due to, inter alia, steam cracking of saturated hydrocarbon (ethane, propane, butanes, and the like) to make olefins. Such hydrogen-rich fuel gas may comprise, in addition to
30 molecular hydrogen, hydrocarbons such as methane, ethane, propane, butanes, and the like. Flames produced from burning hydrogen-rich fuel gas tend to have higher flame speed than those produced from natural gas. Higher flame speed tends to cause the flame to attach more closely to the burner tip resulting in higher burner tip temperature. As a result, thermal
35 management of burners burning hydrogen-rich fuel gas is more important than those burning natural gas.

[0027] Referring to the examples of burner sub-systems illustrated in Figs. 1-4, a burner sub-system **10** includes a freestanding burner tube **12** located in a well ending with a floor

5 burner opening in a furnace floor segment **14**. The burner tube **12** includes an upstream end **16**, a downstream end **18** and a venturi portion **19**. A burner tip **20** is located at the downstream end **18** and is surrounded by an annular tile enclosure **22**. A fuel orifice **11**, which may be located within fuel spud **24**, is located at the top end of a gas fuel riser **65** and is located at the upstream end **16** of tube **12** and introduces fuel into the burner tube **12**. Fresh
10 or ambient air is introduced into a primary air chamber **26** through an adjustable damper **37b** to mix with the fuel at the upstream end **16** of the burner tube **12** and pass upwardly through the venturi portion **19**. Combustion of the fuel and fresh air occurs downstream of the burner tip **20**.

[0028] Multiple air ports **30** (Figs. 2 and 3) originate in a secondary air chamber **32** and
15 pass through the furnace floor segment **14** into the furnace. Fresh or ambient air enters the secondary air chamber **32** through adjustable dampers **34** and passes through the staged air ports **30** into the furnace to provide secondary or staged combustion.

[0029] In order to recirculate flue gas from the furnace to the primary air chamber, FGR duct **76** extends from FGR duct opening **40**, in the floor of the furnace into the primary air
20 chamber **26**. Alternatively, multiple passageways (not shown) may be used instead of a single passageway. Flue gas is drawn through FGR duct **76** by the inspirating effect of fuel passing through venturi **19** of burner tube **12**. In this manner, the primary air and flue gas are mixed in primary air chamber **26**, which is prior to the zone of combustion. Therefore, the amount of inert material mixed with the fuel is raised, thereby reducing the flame temperature, and as
25 a result, reducing NO_x emissions. Closing or partially closing damper **37b** restricts the amount of fresh air that can be drawn into the primary air chamber **26** and thereby provides the vacuum necessary to draw flue gas from the furnace floor.

[0030] Mixing is promoted by providing two or more primary air channels **37**
30 and **38** protruding into the FGR duct **76**. The channels **37** and **38** are conic-section, cylindrical, or squared and a gap between each channel **37** and **38** produces a turbulence zone in the FGR duct **76** where good flue gas/air mixing occurs.

[0031] The geometry of channels **37** and **38** is designed to promote mixing by increasing
35 air momentum into the FGR duct **76**. The velocity of the air is optimized by reducing the total flow area of the primary air channels **37** and **38** to a level that still permits sufficient primary air to be available for combustion, as those skilled in the art are capable of determining through routine trials.

[0032] Mixing is further enhanced by a plate member **83** at the lower end of the inner
wall of the FGR duct **76**. The plate member **83** extends into the primary air chamber **26**. Flow

5 eddies are created by flow around the plate of the mixture of flue gas and air. The flow eddies provide further mixing of the flue gas and air. The plate member **83** also makes the FGR duct **76** effectively longer, and a longer FGR duct also promotes better mixing.

[0033] The improvement in the amount of mixing between the recirculated flue gas and the primary air caused by the channels **37** and **38** and the plate member **83** results in a higher
10 capacity of the burner to inspirate flue-gas recirculation and a more homogeneous mixture inside the venturi portion **19**. Higher flue-gas recirculation reduces overall flame temperature by providing a heat sink for the energy released from combustion. Better mixing in the venturi portion **19** tends to reduce the hot-spots that occur as a result of localized high oxygen regions.

15 [0034] Unmixed low temperature ambient air (primary air), is introduced through angled channels **37** and **38**, each having a first end comprising an orifice **37a** and **38a**, controlled by damper **37b**, and a second end comprising an orifice which communicates with FGR duct **76**. The ambient air so introduced is mixed directly with the recirculated flue gas in FGR duct **76**. The primary air is drawn through channels **37** and **38**, by the inspirating effect of the fuel
20 passing through the fuel orifice, which may be contained within gas spud **24**. The ambient air may be fresh air as discussed above.

[0035] Additional unmixed low temperature ambient air, having entered secondary air chamber **32** through dampers **34** is drawn through orifice **62**, through bleed air duct **64**, through orifice **97** into FGR duct **76** and into the primary air chamber **26** by the inspirating
25 effect of the fuel passing through venturi portion **19**. The ambient air may be fresh air as discussed above. The mixing of the cool ambient air with the flue gas lowers the temperature of the hot flue gas flowing through FGR duct **76** and thereby substantially increases the life of FGR duct **76** and allows use of this type of burner to reduce NO_x emission in high temperature cracking furnaces having flue gas temperature above 1900° F. in the radiant
30 section of the furnace. Bleed air duct **64** has a first end **66** and a second end **68**, first end **66** connected to orifice **62** of secondary air chamber **32** and second end **68** connected to orifice **97** of FGR duct **76**.

[0036] Additionally, a minor amount of unmixed low temperature ambient air, relative to that amount passing through bleed air duct **64**, having passed through air ports **30** into the
35 furnace, may also be drawn through FGR duct **76** into primary air chamber **26** by the inspirating effect of the fuel passing through venturi portion **19**. To the extent that damper **37b** is completely closed, bleed air duct **64** is desirably sized so as to permit the necessary flow of the full requirement of primary air needed by burner **10**.

5 [0037] The flue-gas recirculated to the burner is mixed with a portion of the cool staged
air in the FGR duct 76. This mixing reduces the temperature of the stream flowing in the
FGR duct 76, and enables readily available materials to be used for the construction of the
burner. This feature is useful for the burners of high temperature furnaces such as steam
crackers or reformers, where the temperature of the flue-gas being recirculated can be as high
10 as 1900°F -2100°F. By combining approximately one pound of staged-air with each pound of
flue-gas recirculated, the temperature within the FGR duct can be advantageously reduced.

[0038] One or more passageways connecting the secondary air chamber directly to the
flue-gas recirculation duct induce a small quantity of low temperature secondary air into the
FGR duct 76 to cool the air/flue-gas stream entering in the metallic section of the FGR
15 duct 76. By having the majority of the secondary air supplied directly from the secondary air
chamber, rather than having the bulk of the secondary air traverse across the furnace floor
prior to entering the FGR duct, beneficial results are obtained, as demonstrated by the
Examples below.

[0039] Advantageously, a mixture of from about 20% to about 80% flue gas and from
20 about 20% to about 80% ambient air is drawn through FGR duct 76. It is particularly
preferred that a mixture of about 50% flue gas and about 50% ambient air be employed. The
desired proportions of flue gas and ambient air may be achieved by proper sizing, placement
and/or design of FGR duct 76, bleed air ducts 64 and air ports 30, as those skilled in the art
will readily recognize. That is, the geometry and location of the air ports and bleed air ducts
25 may be varied to obtain the desired percentages of flue gas and ambient air.

[0040] A sight and lighting port 50 is provided in the primary chamber 26, both to allow
inspection of the interior of the burner assembly, and to provide access for lighting of the
burner 10 with lighting element (not shown). The burner plenum may be covered with
mineral wool or ceramic fiber insulation 52 and wire mesh screening (not shown) to provide
30 insulation therefor. The lighting chamber 99 is located at a distance from burner
tip 20 effective for burner light off. A lighting torch or igniter (not shown) of the type
disclosed in U.S. Patent No. 5,092,761 has utility in the start-up of the burner. To operate the
burner, the torch or igniter is inserted through light-off port 50 into the lighting chamber 99,
which is adjacent burner tip 20, to light the burner 10.

35 [0041] In operation, fuel orifice 11, which may be located within gas spud 24, discharges
fuel into burner tube 12, where it mixes with primary air, recirculated flue gas or mixtures
thereof. The mixture of fuel, recirculated flue-gas and primary air then discharges from
burner tip 20. The mixture in the venturi portion 19 of burner tube 12 is maintained below the

5 fuel-rich flammability limit; i.e. there is insufficient air in the venturi to support combustion. Secondary air is added to provide the remainder of the air required for combustion.

[0042] In addition to the use of flue gas as a diluent, another technique to achieve lower flame temperature through dilution is through the use of steam injection. Steam can be injected in the primary air or the secondary air chamber. Steam may be injected through one
10 or more steam injection tubes **15**, as shown in Fig. **1**. Preferably, steam is injected upstream of the venturi.

[0043] The cross-section of FGR duct **76** is substantially rectangular, typically with its minor dimension ranging from 30% to 100% of its major dimension. Conveniently, the cross sectional area of FGR duct **76** ranges from about 5 square inches to about 12 square
15 inches/million (MM) Btu/hr burner capacity and, in a practical example, from 34 square inches to 60 square inches. In this way the FGR duct **76** can accommodate a mass flow rate of at least 100 pounds per hour per MM Btu/hr burner capacity, preferably at least 130 pounds per hour per MM Btu/hr burner capacity, and still more preferably at least 200 pounds per hour per MM Btu/hr burner capacity. Moreover, FGR ratios of greater than 10% and up
20 to 15% or even up to 20% can be achieved.

[0044] With reference to Figs. 1-3 and Fig. **12** and in one example of the present invention, a barrier wall segment **60** between burner tip **20** mounted on the downstream end **18** of the burner tube **12** and the FGR duct opening **40** to provide a barrier between a
25 base of a flame downstream of the burner tip **20** and the FGR duct opening **40**. The barrier wall segment **60** blocks direct gas flow between the burner floor opening and the FGR duct opening, thereby reducing the temperature inside the FGR duct, the NO_x formation in the furnace, and increasing the stability of the flame.

[0045] U.S. Patent No. 6,877,980 B2 discloses a substantially similar burner sub-system (shown in Fig. 12A) with the distinction of the presence of an annular barrier wall between
30 the burner tip and FGR duct opening and the air ports. The annular structure of the barrier wall in that design indeed reduces turbulence caused to the flame by gas flows to and from the adjacent ports. Such burner design with annular barrier wall performed satisfactorily when low-hydrogen fuel gas or natural gas is used as the fuel for the burner. However, it has been found that, when hydrogen-rich fuel gas is supplied to the burner resulting in higher
35 flame temperature, the heat reflected by the annular barrier wall to the burner tip can be substantial enough to cause the burner tip to overheat, especially at turn-down of the burner and flame flash back, leading to premature failure of the burner tip.

- 5 [0046] In the burner-subsystem of the present invention, a non-annular barrier segment between the burner tip and the FGR duct opening is installed. It has been found that a partial barrier wall segment can be sufficient to block direct gas flow between the periphery of the tile enclosure and the FGR duct opening, preventing flame from entering the FGR duct, and achieving a sufficiently low NO_x level in the exhaust. In addition, by employing only a
10 segment of the barrier wall, the amount of heat reflected from the barrier wall to the burner tip can be reduced significantly, thereby reducing the burner tip temperature, preventing it from overheating especially during burner turn-down or fame flash back and premature failure. This design was found to be particularly advantageous in furnaces where hydrogen-rich flue gas is used, leading to prolonged burner tip life.
- 15 [0047] Thus, the barrier wall segment **60** in the burner sub-system of the present invention generally has a width resulting in an angle of view (alpha) no greater than 180° when viewed from the point where the vertical centerline of the burner tip intercepts the horizontal plane of the furnace floor segment. In general, $\alpha_1 \leq \alpha \leq \alpha_2$, where alpha1 and alpha2 can be, independently, 1, 3, 5, 10, 15, 20, 30, 40, 50, 60, 70, 80, 90, 100,
20 110, 120, 130, 140, 150, 160, 170, 180, as long as $\alpha_1 < \alpha_2$.
- [0048] Exemplary barrier wall segment **60** in the burner sub-system of the present invention blocks at least 50% (or at least 60%, 70%, 80%, 90%, 95%, or even 100%) of the line of sight of the FGR duct opening, when viewed from the point where the vertical centerline of the burner tip intercepts the plane of the furnace floor segment. Preferably, the
25 center lines of the angles of view of the barrier wall segment and the FGR duct opening, when viewed from the point where the vertical centerline of the burner tip intercepts the horizontal plane of the furnace floor segment, are substantially adjacent to each other. Thus, the angle formed between the center lines of the these two angles of views is desired to be no higher than 30° (or no higher than 25°, 20°, 15°, 10°, 5°, 3°, or even 1°).
- 30 [0049] Preferably, the angle of view of the barrier wall segment (alpha) is larger than the angle of view of the FGR duct opening (beta), when viewed from the point where the vertical centerline of the burner tip intercepts the plane of the furnace floor segment. Thus, $r_1 \leq \alpha/\beta \leq r_2$, where r1 and r2 can be, independently, 1.0, 1.2, 1.3, 1.4, 1.5, 1.6, 1.7, 1.8, 1.9, 2.0, 2.1, 2.2, 2.3, 2.4, 2.5, 2.6, 2.7, 2.8, 2.9, 3.0, as long as $r_1 < r_2$.
- 35 [0050] Exemplary barrier wall segment has a height of from h1 centimeters to h2 centimeters extending above the furnace floor segment plane, where h1 and h2 can be, independently, 2, 4, 6, 8, 10, 12, 14, 16, 18, 20, 22, 24, 26, 28, 30, 35, 40, 45, or 50, as long

5 as $h_1 < h_2$. It is desired that the area of the furnace floor segment between the periphery of the floor burner opening and the air ports **30** is substantially flat.

[0051] In certain preferred examples, the barrier wall may comprise a center portion and one or two support structure portion(s) connected to the end of the center portion. The support structure portion(s) generally curve(s) away from the center of the floor burner
10 opening. The support structure portion desirably has an average height lower than the center portion. The center portion may have a substantially uniform height, while the support structure portion may taper off from next to the center portion to the end thereof. The support structure portion can further deflect gas flow from the floor burner opening to the FGR duct opening, and provide mechanical support to the center portion. In a specific example, the
15 barrier wall comprises a center portion blocking one side of a FGR duct opening, and two support structure portions blocking at least a portion of two other sides of the FGR duct opening. The barrier wall segment can be advantageously made from refractory materials such as ceramic, glass-ceramic, and the like.

[0052] The burner sub-system of the present invention may further include a centering
20 plate as is now described with reference to Figs. 1 and 5. Support members **161** suspend a perforated centering plate **160** from the roof of the primary air chamber **26**. As shown in Fig. 5, a specific example of the perforated centering plate **160** has multiple spokes **162** interconnecting a riser centering member **163** and a peripheral ring support member **164**. The riser centering member **163** is positioned about the gas riser **65** for
25 maintaining the fuel orifice/gas spud in proper alignment with the inlet to the venturi portion **19**. The ring member **164** has multiple holes **166** for use in securing the centering plate **160** to the support members **161**.

[0053] In one specific example, centering plate **160** also contains a pair of holes **168** to permit a corresponding pair of steam injection tubes **15** to pass through centering plate **160** to
30 the extent such steam injection tubes **15** are present.

[0054] As noted above, the centering plate **160** is perforated to permit flow therethrough of air from the primary air chamber **26**, which avoids flow losses that result from a normally tortuous flow pattern caused by a presently used solid centering plate. These flow losses are avoided because the perforated centering plate design smoothes out the flow vectors entering
35 the venturi portion **19** of the burner tube to enable higher venturi capacity, higher flue-gas recirculation rate, lower flame temperature and lower NO_x production.

[0055] Although centering plate **160** as shown in Fig. 5 is illustrated as circular and although a circular shape is the preferred, it will be understood by those of skill in the art that

5 the centering plate may be formed into many other shapes, including, for example, oval, square, or triangular without departing from the scope or spirit of the present invention.

[0056] The burner useful in the sub-system of the present invention may employ an advantaged fuel spud as is now described with specific reference to Fig. 3, Fig. 6A and Fig. 6B. Referring now to Fig. 6A, a conventional fuel spud **24** is shown. Fuel spud **24** is affixed to the outlet end of fuel supply pipe **25**, preferably by threads, as shown. Fuel spud **24** is aligned with the upstream end **16** of burner tube **12**, so that fuel exiting the outlet end **29** of fuel spud **24** will flow into the upstream end **16** of burner tube **12**, together with primary air and recirculated flue gas. As shown, the inner diameter of the inlet end **23** of fuel spud **24** transitions to a smaller diameter at outlet end **29** through the use of transition section **27**. The outer surface **21** of fuel spud **24** is exposed to the venturi inlet flow stream, represented by streamlines S. Outer surface **21** is in the form of a hex-shaped nut, for ease in installation.

[0057] While outer surface **21** may be helpful in the installation of fuel spud **24**, as is illustrated by streamlines S of Fig. 6A, when air is drawn into the venturi inlet **16**, flow past the edges of fuel spud **24** can generate a zone of eddies and turbulence immediately adjacent to the highest velocity portion of fuel spud **24**. The energy dissipated in this zone of eddies reduces the inspirating efficiency of the fuel spud **24** and burner tube **12** venturi combination. This inefficiency can limit the FGR ratio achievable in the burner.

[0058] Fig. 6B depicts a fuel spud **424**, designed in accordance with another preferred form. As shown, fuel spud **424** employs a smoothly profiled outer surface **421**, which takes the form of a frustum of a cone, to eliminate flow separation and eddies as the air and recycled flue gas pass over fuel spud **424** into upstream end **16** of burner tube **12**. As schematically depicted by flow streamlines Sⁱ, eddies and turbulence are minimized, thus improving the inspirating efficiency of the system. Use of this fuel spud design can improve the inspiration characteristics of the fuel spud/burner tube/venturi combination, increasing the ability to utilize higher levels of FGR and reduce NO_x emissions.

[0059] An advantaged burner tip **20** useful in the burner sub-system of the present invention is now discussed with specific reference to Figs. **1**, **2**, **3** and **8**. A very small gap exists between the burner tip **20** and the burner tile enclosure **22**. By precisely engineering this gap, the bulk of the secondary staged air is forced to enter the furnace through staged air ports **30** located some distance from the primary combustion zone, which is located immediately on the furnace side of the burner tip **20**. This gap may be a single peripheral gap, or alternatively, comprise a series of spaced gaps **70** peripherally arranged, as shown in Fig. **8**.

5 [0060] In connection with the advantaged burner spud **24** and burner tip **20** described above, the mixture of fuel, recirculated flue gas and primary air discharges from burner tip **20**. The mixture in the venturi portion **19** of burner tube **12** is maintained below the fuel-rich flammability limit; i.e. there is insufficient air in the venturi to support combustion. Staged, secondary air is added to provide the remainder of the air required for combustion. The majority of the staged air is added a finite distance away from the burner tip **20** through 10 staged air ports **30**. However a portion of the staged, secondary air passes between the burner tip **20** and the annular tile enclosure **22** and is immediately available to the fuel exiting the side ports **568** of burner tip **20**. As indicated, side-ports **568** direct a fraction of the fuel across the face of the annular tile enclosure **22**, while main ports **564**, direct the major portion of the 15 fuel into the furnace.

[0061] As may be envisioned, two combustion zones are established. A small combustion zone is established across the face of the peripheral tile enclosure **22**, emanating from the fuel combusted in the region of the side ports **568**, while a much larger combustion zone is established projecting into the furnace firebox, emanating from the fuel combusted from the 20 main ports **564**. In operation, the larger combustion zone represents an approximately cylindrical face of combustion extending up from the burner, where the staged air flowing primarily from air ports **30** meets the fuel-rich mixture exiting from the burner tip main ports **564**.

[0062] The combustion zone adjacent to the side ports **568** and peripheral tile enclosure **22** contributes to flame stability. To provide adequate flame stability, the air/fuel mixture in this zone, which comprises the air/fuel mixture leaving the side ports **568** of burner tip **20**, plus the air passing between the burner tip **20** and the peripheral tile enclosure **22**, is desirably above the fuel-rich flammability limit.

[0063] While a mixture above the fuel-rich flammability limit in the combustion zone adjacent to the side ports **568** and peripheral tile enclosure **22** assures good burner stability, 30 combustion in this zone tends to generate relatively high NO_x levels compared to the larger combustion zone. Overall NO_x emissions may be reduced by minimizing the proportion of fuel that is combusted in this smaller combustion zone. More particularly, in a staged-air, pre-mix burner employing integral flue-gas recirculation, when the quantity of fuel discharged into the combustion zone adjacent to side ports **568** and peripheral tile enclosure **22** does not 35 exceed about 15% of the total fuel fired in the burner, lower overall NO_x emissions are experienced. This is achieved by further assuring that the gas flow between burner tip **20** and the peripheral tile enclosure **22** is such that combustion takes place within this zone with a

5 mixture sufficiently above the fuel-rich flammability limit to assure good burner stability, but without the high oxygen concentrations that lead to high NO_x emissions.

[0064] The advantaged burner tip design described above limits the fuel discharged into the combustion zone adjacent to the side ports **568** and peripheral tile enclosure **22** to about eight percent of the total fuel. This design advantageously maintains the desired air/fuel ratio
10 in this combustion zone, while maintaining a burner-tip-to-peripheral-tile enclosure gap of between about 0.15" to about 0.40". As shown, rather than have two rows of about thirty side ports, as is common in conventional designs, the advantaged burner tip **20** has two rows of 16 side ports **568**, each side port having a diameter of about 6 mm. Advantageously, with this design, NO_x emissions are reduced without the problems normally associated with reduced
15 flame temperature and flame speed. The result is a very stable flame that is not prone to "lift-off." Reducing the diameter of the side ports **568** to about 5 mm also helps limit the fuel discharged into the combustion zone adjacent to the side ports **568** and peripheral tile enclosure **22** to between about 5 and 15 percent of the total fuel fired, while still producing a very stable flame.

[0065] In one example, burner tip **20** has an upper end **566** which, when installed, faces the burner box and a lower end adapted for mating with the downstream end **18** of burner tube **12**. Mating of the lower end of burner tip **20** to the burner tube **12** can be achieved by swaging or, more preferably, by welding or threaded engagement.

[0066] Referring specifically to Figs. 3, **8**, and **9A**, the upper end **566** of the burner tip **20** includes multiple main ports **564** in a centrally disposed end surface **569** and multiple
25 side ports **568** in a peripheral side surface. In operation, the side ports **568** direct a portion of the fuel/air mixture across the face of the tile enclosure **22**, whereas the main ports **64** direct the major portion of the mixture into the furnace.

[0067] Referring now to Figs. **9A** and **9B**, the upper end **566** of the burner tip **20** of Fig. **1** is shown in Fig. **9A**, whereas Fig. **9B** shows the upper end **666** of a second, differing burner tip **20**. Referring to Fig. **9A**, it will be seen that the number and size of the main ports **564** in the centrally disposed end surface **569** of the burner tip **20** are significantly larger than those of the second tip. In particular, the number and dimensions of the main ports **564** in the tip of FIGs. **1** and **9A** are such that the total area of the main ports **564** in the end surface **569** is at
35 least 1 square inch, preferably at least 1.2 square inch, per million (MM) Btu/hr burner capacity. In contrast, in the second burner tip shown in Fig. **9B**, the total area of the main ports **664** in the end surface **669** is less than 1 square inch per MMBtu/hr burner capacity. Referring again to Fig. **9A**, in one practical example of a burner tip useful in the burner sub-

5 system according to the invention, wherein the design firing rate of the burner is 6.0 MM Btu/hr, the total area of the main ports **564** in the end surface **569** is 8.4 in² whereas, in the second burner tip for use at the same design firing rate, the total area of these openings is only 5.8 in². The drop in tip velocity can be mitigated by the fact that raising tip flow area raises FGR. The increased total area of the main ports **564** in the burner tip **20** results in an
10 increase in the flow area of the burner tip **20**, which in turn enables higher FGR, rates to be induced without increasing the velocity for the fuel/air mixture flowing through the tip. In this way, stable operation of the burner can be retained with higher FGR rates.

[0068] The reduction in the number of side ports necessary to achieve a low NO_x emissions level is dependent upon a number of factors including the properties of the fuel,
15 itself, the dynamics of fluid flow and the kinetics of combustion. While the burner tips **20** described above having about a 53% reduction in the number of side ports, it would be expected that reductions in the number of side ports ranging from about 25% to about 75% could be effective as well, so long as each side port and the burner-tip-to-peripheral-tile enclosure gap is appropriately sized.

[0069] In the advantaged burner tip design described above, preferably the dimensions of the burner-tip-to-peripheral-tile enclosure gap are such that the total air available to the fuel gas exiting the side ports (i.e. the sum of air exiting the side ports with the fuel gas, plus the air supplied through gap), is between about 5 to about 15 percentage points above the Fuel Rich Flammability Limit for the fuel being used. For example, if the fuel being used has a
25 Fuel Rich Flammability Limit of 55% of the air required for stoichiometric combustion, the air available to the fuel gas exiting the side ports desirably represents 60-65% of the air required for stoichiometric combustion.

[0070] Use of the advantaged burner tip described above serves to substantially minimize localized sources of high NO_x emissions in the region near the burner tip.

[0071] The burner **10** useful in the burner sub-system of the present invention may also comprise a venturi **19** as now discussed. Referring now to Fig. 7A, a venturi **19** of a conventional burner, of the type disclosed in U.S. Patent No. 5,092,761, includes a relatively short throat portion **19a** that is of substantially constant internal cross-sectional dimensions along its length and a divergent cone portion **19b**, wherein the ratio of the length to maximum
35 internal cross-sectional dimension of the throat portion **19a** is less than 3, typically 2.6. As shown in Fig. 7B, a venturi of a burner tube of a burner useful in an advantaged burner-system of the present invention includes a throat portion **19a** of substantially constant internal cross-sectional dimensions and a divergent cone portion **19b**. However, the throat

5 portion **19a** of the burner is significantly longer than that of the conventional burner, as shown in Fig. 7A such that the ratio of the length to maximum internal cross-sectional dimension of the throat portion **19a** is at least 3, preferably from about 4 to about 10, more preferably from about 4.5 to about 8, still more preferably from about 6.5 to about 7.5 and most preferably from about 6.5 to about 7.0. The internal surface of the throat portion **19a** of
10 the burner sub-system of the present invention is preferably cylindrical.

[0072] Increasing the ratio of length to internal cross-sectional dimensions in the throat portion of the venturi can reduce the degree of flow separation that occurs in the throat and cone portions of the venturi which increases the capacity of the venturi to entrain flue gas thereby allowing higher flue-gas recirculation rates and hence reduced flame temperature and
15 NO_x production. A longer venturi throat also promotes better flow development and hence improved mixing of the fuel gas/air stream prior to the mixture exiting the burner tip **20**. Better mixing of the fuel gas/air stream also contributes to NO_x reduction by producing a more evenly developed flame and hence reducing peak temperature regions.

[0073] The non-limiting burner **10** particularly useful in the burner sub-system of the present invention may include a lighting chamber arrangement as will now be discussed with particular reference to Figs. **1**, **3** and **8**. Increasing the gap between the burner tip **20** and the burner tile enclosure **22** raises the overall NO_x emissions produced by the burner, but also raises overall flame stability. The size of the gap is desirably sized such that it is small enough to minimize NO_x, and large enough to maintain adequate flame stability. In this
20 regard, lighting chamber **99** may be seen to pose a problem. To substantially eliminate the effect on NO_x emissions created by the presence of lighting chamber **99**, which provides a significant cross-sectional flow area for additional air to pass, a removable lighting chamber plug **362** having a shape effective to substantially fill lighting chamber **99** when positioned within lighting chamber **99** is provided.

[0074] To operate the burner **10** useful in the burner-system of the present invention, a torch or igniter is inserted through light-off tube **50** into the lighting chamber **99**, which is adjacent to the primary combustion area and burner tip **20**, to light the burner. Following light-off, the lighting chamber **99** is plugged-off by inserting removable lighting chamber plug **362** through light-off tube **50** into the lighting chamber **99**, for normal operation,
35 eliminating the zone of high oxygen concentration adjacent to the primary combustion zone, and thus reducing the NO_x emissions from the burner. For ease of installation, the lighting chamber plug **362** may be affixed to an installation rod, to form lighting chamber plug assembly **368**, which is inserted through light-off tube **50** into lighting chamber **99**. The use

5 of the removable lighting chamber plug assembly **368** allows convenient attachment to the burner plenum through mechanical attachment of installation rod to burner plenum.

[0075] The removable lighting chamber plug **362** and assembly is advantageously constructed of materials adequate for the high temperature environment inside the furnace. The face **364** of the removable lighting chamber plug **362**, which is the surface exposed to the
10 furnace and which fits into burner tile enclosure **22**, may be profiled to form an extension of the axi-symmetric geometry of the burner tile enclosure **22**, thus creating a flush mounting with the burner tile enclosure **22**, as shown in Fig. 1. The lighting chamber plug **362** is constructed of a ceramic or high temperature refractory material suitable for temperatures in the range of from 2600 to 3600°F, as is typical for furnace burner tile enclosures. One material having
15 utility in the practice of the present invention is a ceramic fiber blanket, such as Kaowool® Ceramic Fiber Blanket, which may be obtained from Thermal Ceramics Corporation of Atlanta, GA, in commercial quantities. The burner plenum may be covered with mineral wool and wire mesh screening **52** to provide insulation therefor.

[0076] The burner **10** useful in the burner sub-system of the present invention may also
20 include a tip seal arrangement as will now be discussed in connection with Figs. 3, 8, 10A-10C, and 11. Increasing the available flow area of the gap between the burner tip **20** and the peripheral burner tile enclosure **22** raises the overall NO_x emissions produced by the burner, although it tends to also benefit flame stability. In view of its impact on NO_x emissions, each gap between the burner tip **20** and the burner tile enclosure **22** is carefully sized to maintain
25 stability and minimize NO_x. The outer diameter of the burner tip **20** and the gas flow notches **70** can be manufactured to relatively tight tolerances through investment casting or machining. However, the peripheral tile enclosure **22** is more difficult to manufacture to the same tolerances, creating an unwanted gap between the outer diameter of the burner tip **20** and the peripheral tile enclosure **22**. Typically, a peripheral tile enclosure is poured into
30 a mold using a castable refractory material. Compounding the problem of producing peripheral burner tile enclosures to tight tolerances is the amount of shrinkage that the tile enclosures experience when dried and fired. The amount of shrinkage varies according to material, temperature, and geometry, causing additional uncertainties in the final manufactured tolerances. These factors contribute to the difficulty in consistently
35 manufacturing a tile enclosure to a specified diameter, which can lead to a tile enclosure that is too small in diameter or, more commonly, one that is too large in diameter.

[0077] To establish a uniform dimension between the burner tip **20** and the peripheral burner tile enclosure **22** for the air gaps **70**, a burner tip band **85**, which may be formed of

5 steel or other metal or metal composite capable of withstanding the harsh environment of an industrial burner, is attached to the outer periphery of burner tip **20**, by tack welding or other suitable means. Advantageously, a compressible high temperature material **87** is optionally employed in the unwanted gap between the burner tip band **85** and the peripheral tile enclosure **22** to further reduce or eliminate the gap. Burner tip band **85** may further include a
10 peripheral indentation **81** (see Fig. 10A) or peripheral indentation **83** (see Fig. 10C), respectively, for seating said compressible high temperature material. An advantage of this design is that the peripheral tile enclosure hole size can vary significantly, while the compressible material can adjusted for this variance in order to maintain the seal between the burner tip **20** and peripheral tile enclosure **22**. By using this design of the burner sub-system,
15 the air gap between the burner tip and peripheral tile enclosure can be maintained to exacting tolerances, essentially eliminating unwanted air leakage.

[0078] Compressible material **87** is desirably rated for high temperature service since it is very close to the burner side port flames. A material that expands when heated is very useful as compressible material **87** because it makes the initial installation much easier. Examples of
20 suitable materials include, but are not limited to; Triple T™ by Thermal Ceramics and Organically Bound Maftec™ (OBM Maftec™) distributed by Thermal Ceramics of Atlanta, Ga., a division of Morgan Crucible. OBM Maftec™ is preferable since it held together better after being exposed to high temperatures. OBM Maftec™ is produced from high quality mullite fiber. This material is known to possess low thermal conductivity and heat storage
25 and is resistant to thermal shock and chemical attack. It additionally is highly flexible, has a maximum temperature rating of 2900°F and a continuous use limit of up to 2700°F, making it ideal for this application. While the Triple T™ material expands more than the Maftec™, it was found to flake apart more easily after heating.

[0079] Referring now to Fig. 11, a similar benefit may be obtained in the region of
30 pilot **86**, adjacent to the first opening in the furnace. Leakage can occur in typical designs due to gaps existing around the pilot shield **88**. To remedy this, a compressible high temperature material **87** is installed around the pilot shield **88**, and/or pilot riser **89** to eliminate the unwanted gap between the burner tip band **85** and the peripheral tile enclosure **22**, as shown in Fig. 11. A one inch wide by 0.1875 inch thick strip of OBM Maftec™ works particularly
35 well to seal gaps existing around the pilot shield **88**.

[0080] The burner sub-system of the present invention also comprises a FGR duct, which may be angled, as next discussed in connection with Figs. 1-3. The FGR duct **76** angles outwardly at **84** such that the FGR duct opening **40** of the duct **76** is physically further

5 spaced away from the base of the burner tip **20**. The angled FGR duct inlet **84** thus avoids or at least reduces the potential for the burner flame to be entrained into the FGR duct **76**. This design enables higher flue-gas recirculation (FGR) rates to be induced into the burner **10**. Such higher FGR rates, in turn, reduce overall flame temperature and NO_x production.

[0081] With reference to the non-limiting example shown in Fig. 3, a flame opening **523** is circular and has a radius R, and the distance (d) that the duct opening **40** is laterally spaced from the flame opening **523** is defined by $d \geq 0.5 R$ for avoiding entrainment of the flame into the duct opening **40**.

[0082] Referring again to Fig. 1, the angle outward at **84** also permits the continued use of the relatively small burner box. Such FGR burners may be desirably in the order of 6 feet in height by 3 feet in width.

[0083] In addition to the use of flue gas as a diluent, another technique to achieve lower flame temperature through dilution is through the use of steam injection. Steam can be injected in the primary air or the secondary air chamber. Preferably, steam may be injected upstream of the venturi.

20 [0084] Fig. 13 is a schematic illustration of a steam cracking furnace **1301** for producing olefins from hydrocarbon feeds in operation. The furnace **1301** comprises a radiant firebox defined by a furnace floor and multiple furnace side walls, in which a radiant tube **1303** is being heated by multiple floor-firing flames produced by burner sub-systems **1305** and multiple wide wall burner flames produced by side wall burners installed in the side walls.

25 The side wall burner flames can be advantageously close to the side wall surface, providing thermal inputs conducive to a reduced level of NO_x emissions from the furnace. A hydrocarbon reactant stream flowing through tube **1303** undergoes thermal cracking reactions to produce olefins.

[0085] Referring now to Figs. 14 and 15, a non-limiting example of furnace **1410** is illustrated, which can be used in the production of ethylene from ethane.

30 Furnace **1410** includes a radiant firebox **1402** having a furnace floor **1414** having a centerline L and multiple side walls. Centerline L may be of a width of about a foot or less, for the purposes of the instant disclosure. Multiple floor burners **1411** are arranged along two parallel lines D₁ and D₂ to form a first line of burners **1416** and a second line of burners **1418**,

35 each line of burners spaced a substantially equal distance from the centerline L of furnace floor **1414** and on opposing sides of the centerline L. The non-limiting exemplary furnace **1410** does not use side burner flames produced from side wall burners located on the side walls.

5 [0086] A first plane of radiant coils **1420** is arranged parallel to a plane P passing through the centerline L of the furnace floor **1414** and perpendicular to the furnace floor **1414**. First plane of radiant coils **1420** is spaced at a distance greater than the distance that the first line of burners **1416** is spaced from the centerline L of the furnace floor **1414** and on the same side of the centerline L as the first row of burners **1416**. A second plane of radiant coils **1422**
10 is arranged parallel to plane P passing through the centerline L of furnace floor **1414** and perpendicular to furnace floor **1414**. Second plane of radiant coils **1422** is spaced at a distance greater than the distance that the second line of burners **1418** is spaced from the centerline L of furnace floor **1414** and on the same side of the centerline L as the second row of burners **1418**.

15 [0087] In one form, furnace **1410** may also include a second plurality of burners **1411** arranged along at least two parallel lines D_3 and D_4 to form a third line of burners **1426** and a fourth line of burners **1428**, each line of burners spaced a substantially equal distance from the centerline L of the furnace floor **1414** at a distance greater than the distance that the first plane of radiant coils **1420** and the second plane of radiant
20 coils **1422** are spaced from the centerline L of the furnace floor **1414**, respectively.

[0088] In operation of furnace **1410**, hydrocarbon feed is first preheated and, in the case of liquid feeds commonly at least partially vaporized, and mixed with dilution steam in the convection section **1432** of furnace **1410**. The temperature exiting convection section **1432** is generally designed to be at or near the point where significant thermal cracking commences.
25 Typically, for example, this temperature is about 1050°F (565°C) to about 1150°F (620°C) for gas-oil feeds, about 1150°F (620°C) to about 1250°F (675°C) for naphtha feeds, and about 1250°F (675°C) to about 1350°F (730°C) for ethane feed. After preheating in convection section **1432**, a vapor feed/dilution steam mixture is typically rapidly heated in the radiant section **1434** to achieve the desired level of thermal cracking. The coil outlet
30 temperature (COT) of radiant section **1434** commonly can be in the range of from 1450°F (790°C) to about 1500°F (815°C) for gas oil feeds, about 1500°F (815°C) to about 1600°F (870°C) for naphtha feeds, and about 1550°F (845°C) to about 1650°F (900°C) for ethane feeds. After the desired degree of thermal cracking has been achieved in radiant section **1434**, the furnace effluent is rapidly quenched in either an indirect heat exchanger **1436** and/or by
35 the direct injection of a quench fluid stream (not illustrated).

[0089] In various examples, the plurality of burners **1411** of furnace **1410** may include raw gas burners, staged-fuel burners, staged air burners, premix staged air burners or combinations thereof. In another form the plurality of burners **1411** of furnace **1410** may

5 include premix staged air burners and optionally with combinations including the preceding listed burners. Examples of premix staged air burners may be found in U.S. Pat. Nos. 4,629,413; 5,092,716, and 6,877,980, the contents of which are hereby incorporated by reference in their entirety. With burners of these types, tall flames are produced and commercial experience has confirmed there is no need for supplementary wall mounted
10 burners. While the third line of burners **1426** and the fourth line of burners **1428** may of the same type as the first line of burners **1416** and the second line of burners **1418**, flat-flame burners may be employed the third line of burners **1426** and the fourth line of burners **1428**. As those skilled in the art will readily understand, a flat-flame burner is one that is typically stabilized, at least in part, by the furnace wall.

15 **[0090]** Highly stable flames with a tall height can be achieved by using the burner sub-system of the present invention. Thus it is highly desirable that the furnace firebox has a height of at least 8.0, 8.5, 9.0, 9.5, 10.0, 10.5, 11.0, 11.5, 12.0, 12.5, 13.0, 13.5, 14.0, 14.5, 15.0, 15.5, or even 16.0 meters. The tall walls of the furnace enable tall, stable flames having a height $H(f)$ with a height in the range from $Hf(1)$ to $Hf(2)$, where $Hf(1)$ and $Hf(2)$ can be,
20 independently, 3.0, 3.5, 4.0, 4.5, 5.0, 5.5, 6.0, 6.5, 7.0, 7.5, 8.0, 8.5, 9.0, 9.5, or even 10.0, as long as $Hf(1) < Hf(2)$.

[0091] It is desired that the distance of the vertical centerline of any burner tip to any side wall is at least 30, 35, 40, 45, 50, 55, 60, 65, 70, 75, 80, 85, 90, 95, or 100 centimeters. Such relatively large distance between the flame and the side wall reduces the erosion of the side
25 wall.

[0092] Because the stability of the flames achievable by the burner sub-system of the present invention, it is desirable that in certain examples, there is no intermediate partitioning wall between adjacent burner sub-systems. The burner sub-system enables large furnaces housing multiple rows of burners providing multiple flames capable of heating cracking tubes
30 installed in between to the desired temperature ranges with the desired level of temperature variation. Side wall burner flames produced by side wall burners installed on the side walls of the furnace firebox may be eliminated, substantially reducing the overall cost of the furnace.

[0093] Although the burner sub-system, the furnace, and the processes of this invention
35 have been described in connection with floor-fired hydrocarbon cracking furnaces, they may also be used in furnaces for carrying out other reactions or functions.

5 [0094] It will also be understood that the teachings described herein also have utility in traditional raw gas burners and raw gas burners having a pre-mix burner configuration wherein flue gas alone is mixed with fuel gas at the entrance to the burner tube.

[0095] Thus, it can be seen that, by use of this invention, burner tip can avoid premature failure due to overheating caused by reflection from the barrier wall, especially where
10 hydrogen-rich fuel gas is used. In addition, NO_x emissions may be reduced without the use of fans or otherwise special burners.

[0096] Although the invention has been described with reference to particular means, materials and embodiments, it is to be understood that the invention is not limited to the particulars disclosed and extends to all equivalents within the scope of the claims.

15 [0097] Thus, non-limiting aspects and embodiments of the present invention include:

A1. A burner sub-system comprising:

(a1) a furnace floor segment having a floor burner opening and a flue-gas recirculation duct opening;

(a2) a tile enclosure lining the periphery of the floor burner opening;

20 (a3) a burner comprising a burner tip adjacent and surrounded by the floor burner opening, the burner tip having a vertical centerline and configured to provide a floor burner flame through the floor burner opening;

(a4) a flue-gas recirculation duct opening adjacent the tile; and

25 (a5) a barrier wall segment extending upwards from the upper surface of the furnace floor segment between the flue-gas recirculation duct opening and the burner tip, the barrier wall segment having an angle of view no greater than 180° when viewed from the point where the vertical centerline of the burner tip intercepts a plane of the furnace floor segment.

A2. The burner sub-system of A1, wherein the barrier wall segment has an angle of view no more than 90° when viewed from the point where the vertical centerline of the
30 burner tip intercepts a plane of the furnace floor segment.

A3. The burner sub-system of A1 or A2, wherein the barrier wall segment blocks at least 50% of the line of sight of the flue-gas recirculation duct opening when viewed from the point where the vertical centerline of the burner tip intercepts the plane of the furnace floor segment.

35 A4. The burner sub-system of any of A1 to A3, wherein the barrier wall segment completely blocks the line of sight of the flue-gas recirculation duct opening when viewed from the point where the vertical centerline of the burner tip intercepts the plane of the furnace floor segment.

5 A5. The burner sub-system of any of A1 to A4, wherein the barrier wall segment has a height of from 2 centimeters to 50 centimeters (or 45, 40, 35, 30, 25, or 20 centimeters) above the upper surface of the furnace floor segment.

 A6. The burner sub-system of any of A1 to A5, wherein the barrier wall segment has a center portion and at least one support structure portion connected to the center portion, and
10 the support structure portion is optionally curved away from the center of the floor burner opening.

 A7. The burner sub-system of A6, wherein the center portion is taller than the support structure portions.

 A8. The burner sub-system of A6 or A7, wherein the barrier wall segment at least
15 partly encloses the outer periphery of the flue-gas recirculation duct opening.

 A9. The burner sub-system of A8, wherein the barrier wall segment at least encloses a portion of three sides of the outer periphery of the flue-gas recirculation duct opening.

 A10. The burner sub-system of any of the preceding claims, wherein:
 the burner comprises a burner tube having an upstream end, a downstream end, and a
20 venturi intermediate the upstream end and the downstream end; and
 the burner tip is mounted on the downstream end.

 B1. A furnace comprising:
 (b1) at least one burner sub-system according to any of the claims of A1 – A10;
 (b2) a furnace floor comprising the furnace floor segment of each of the at least one
25 burner sub-system; and
 (b3) one or more furnace side walls;
 wherein the furnace floor and the one or more furnace side walls form a furnace fire
box.

 B2. The furnace of B1, wherein the distance from the vertical centerline of any burner
30 tip to any side wall is at least 30 centimeters.

 B3. The furnace of B1 or B2, which comprises multiple burner sub-systems and is free of any partitioning wall between adjacent burner sub-systems.

 B4. The furnace of any of B1 to B3, wherein the fire box has a height of at least 10.5 meters.

35 B5. The furnace of any of B1 to B4, wherein the fire box has a height of at least 15.0 meters.

 B6. The furnace of any of B1 to B5, further comprising multiple side wall burners configured to produce a side wall burner flame from at least one of the furnace side walls.

5 B7. The furnace of any of B1 to B5, which is free of a side wall burner configured to produce a side wall burner flame from any of the furnace side wall.

 B8. The furnace of any of B1 to B7, comprising at least three burner sub-systems configured to produce at least two rows of floor burner flames projecting upwards.

 C1. A fuel combustion process carried out in a furnace according to any of B1 to B8,
10 the process comprising:

 (c1) supplying a fuel gas comprising at least 50 mol% of hydrogen into the at least one burner sub-system; and

 (c2) combusting the fuel gas to form a floor burner flame above the burner tip inside the furnace fire box.

15 C2. The fuel combustion process of C1, wherein the floor flame has a height of at least 3.0 meters, preferably at most 7.5 meters.

 C3. The fuel combustion process of C1 or C2, wherein the distance from the vertical centerline of any floor burner flame to any side wall is at least 30 centimeters.

 C4. The fuel combustion process of any of C1 to C3, which comprises multiple floor
20 burner flames and is free of any partitioning wall between adjacent floor burner flames.

 C5. The fuel combustion process of any of C1 to C4, further comprising multiple side wall burner flames produced by multiple side wall burners from at least one of the furnace side walls.

 C6. The fuel combustion process of any of C1 to C5, which comprises at least two
25 rows of floor burner flames.

 D1. A steam cracking process comprising a fuel combustion process of any of C1 to C6, wherein a reactant stream comprising a hydrocarbon is heated inside a cracking tube which is heated inside the furnace by the flame.

 D2. The steam cracking process of D1, wherein the reactant stream comprises ethane
30 in the reactant steam.

 D3. The cracking process of D1 or D2, wherein molecular hydrogen is produced in the cracking tube, and at least a portion of the molecular hydrogen constitutes at least a portion of the fuel gas.

CLAIMS:

- 5 1. A burner sub-system comprising:
 a furnace floor segment having a floor burner opening and a flue-gas recirculation
duct opening;
 a tile enclosure lining the periphery of the floor burner opening;
 a burner comprising a burner tip adjacent and surrounded by the floor burner opening,
10 the burner tip having a vertical centerline and configured to provide a floor burner flame
through the floor burner opening;
 a flue-gas recirculation duct opening adjacent the tile; and
 a barrier wall segment extending upwards from the upper surface of the furnace floor
segment between the flue-gas recirculation duct opening and the burner tip, the barrier wall
15 segment having an angle of view no greater than 180° when viewed from the point where the
vertical centerline of the burner tip intercepts a plane of the furnace floor segment.
2. The burner sub-system of claim 1, wherein the barrier wall segment has an angle of
view no more than 90° when viewed from the point where the vertical centerline of the
20 burner tip intercepts a plane of the furnace floor segment.
3. The burner sub-system of claim 1 or claim 2, wherein the barrier wall segment
blocks at least 50% of the line of sight of the flue-gas recirculation duct opening when
viewed from the point where the vertical centerline of the burner tip intercepts the plane of
25 the furnace floor segment.
4. The burner sub-system of any of the preceding claims, wherein the barrier wall
segment completely blocks the line of sight of the flue-gas recirculation duct opening when
viewed from the point where the vertical centerline of the burner tip intercepts the plane of
30 the furnace floor segment.
5. The burner sub-system of any of the preceding claims, wherein the barrier wall
segment has a height of from 2 centimeters to 30 centimeters above the upper surface of the
furnace floor segment.

35

5 6. The burner sub-system of any of the preceding claims, wherein the barrier wall segment has a center portion and at least one support structure portion connected to the center portion.

 7. The burner sub-system of claim 6, wherein the center portion is taller than the support structure portions.

10

 8. The burner sub-system of claim 6 or claim 7, wherein the barrier wall segment at least partly encloses the outer periphery of the flue-gas recirculation duct opening.

 9. The burner sub-system of claim 8, wherein the barrier wall segment at least
15 encloses a portion of three sides of the outer periphery of the flue-gas recirculation duct opening.

 10. The burner sub-system of any of the preceding claims, wherein:
 the burner comprises a burner tube having an upstream end, a downstream end, and a
20 venturi intermediate the upstream end and the downstream end; and
 the burner tip is mounted on the downstream end.

 11. A furnace comprising at least one burner sub-system according to any of the preceding claims, further comprising:
25 a furnace floor comprising the furnace floor segment of each of the at least one burner sub-system; and
 one or more furnace side walls;
 wherein the furnace floor and the one or more furnace side walls form a furnace fire
box.

30

 12. The furnace of claim 11, wherein the distance from the vertical centerline of any burner tip to any side wall is at least 30 centimeters.

 13. The furnace of claim 11 or claim 12, which comprises multiple burner sub-
35 systems and is free of any partitioning wall between adjacent burner sub-systems.

 14. The furnace of any of claims 11 to claim 13, wherein the fire box has a height of at least 10.5 meters.

5

15. The furnace of any of claims 11 to claim 14, wherein the fire box has a height of at least 15.0 meters.

10 16. The furnace of any of claims 11 to claim 15, further comprising multiple side wall burners configured to produce at least one side wall burner flame from at least one of the furnace side walls.

17. The furnace of any of claims 11 to claim 15, which is free of a side wall burner configured to produce a side wall burner flame from any of the furnace side wall.

15

18. The furnace of any of claims 11 to claim 17, comprising at least three burner sub-systems configured to produce at least two rows of floor burner flames projecting upwards.

20 19. A fuel combustion process carried out in a furnace according to any of claims 11 to claim 18, the process comprising:

supplying a fuel gas comprising at least 50 mol% of hydrogen into the at least one burner sub-system; and

combusting the fuel gas to form a floor burner flame above the burner tip inside the furnace fire box.

25

20. The fuel combustion process of claim 19, wherein the floor flame has a height of at least 3.0 meters.

30 21. The fuel combustion process of claim 19 or claim 20, wherein the distance from the vertical centerline of any floor burner flame to any side wall is at least 30 centimeters.

22. The fuel combustion process of any of claims 19 to claim 21, which comprises multiple floor burner flames and is free of any partitioning wall between adjacent floor burner flames.

35

23. The fuel combustion process of any of claims 19 to claim 22, further comprising multiple side wall burner flames produced by multiple side wall burners from at least one of the furnace side walls.

5

24. The fuel combustion process of any of claims 19 to claim 23, which comprises at least two rows of floor burner flames.

25. A steam cracking process comprising a fuel combustion process of any of claims
10 19 to claim 24, wherein a reactant stream comprising a hydrocarbon is heated inside a cracking tube which is heated inside the furnace by the floor burner flame.

FIG. 1

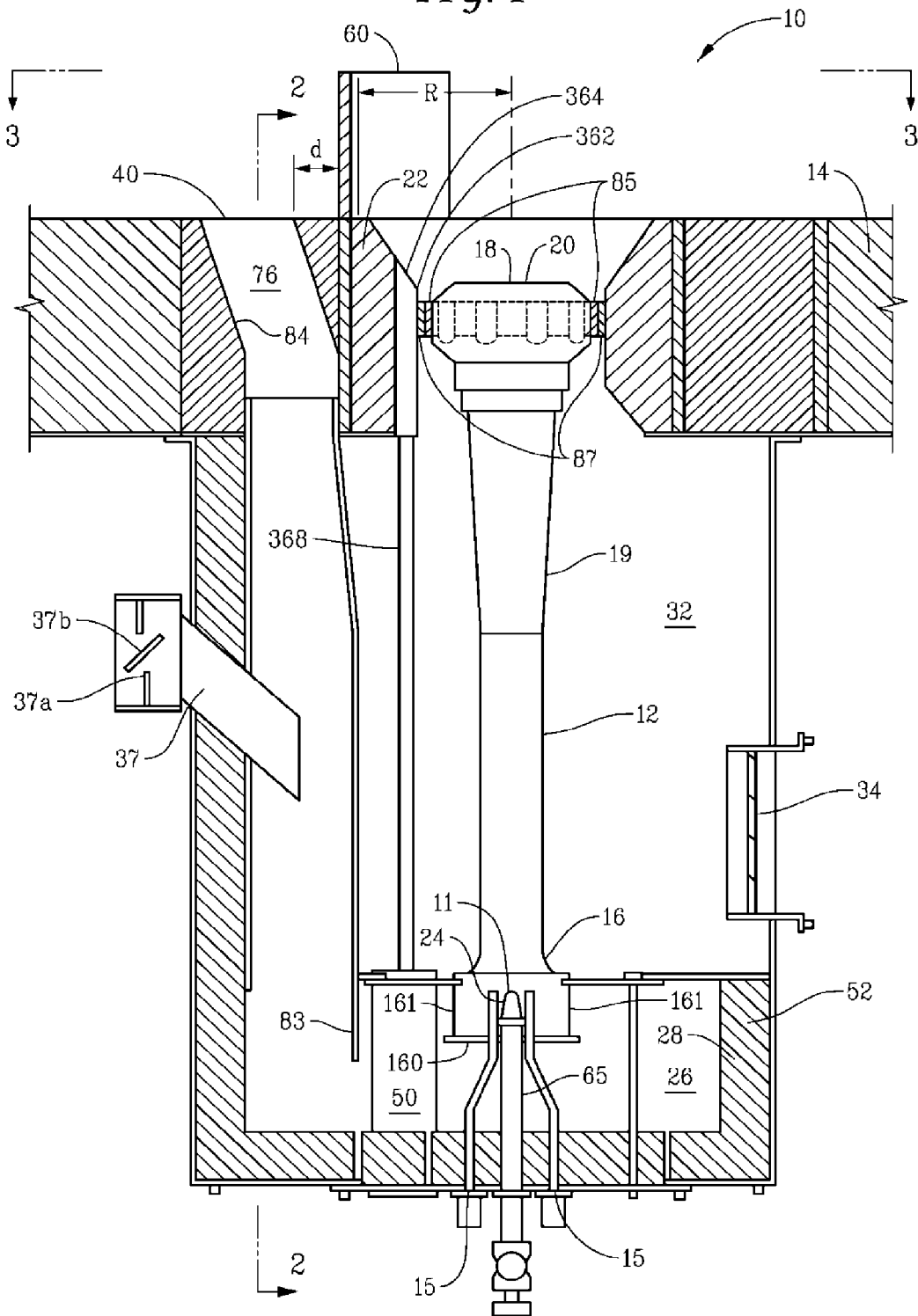

FIG. 2

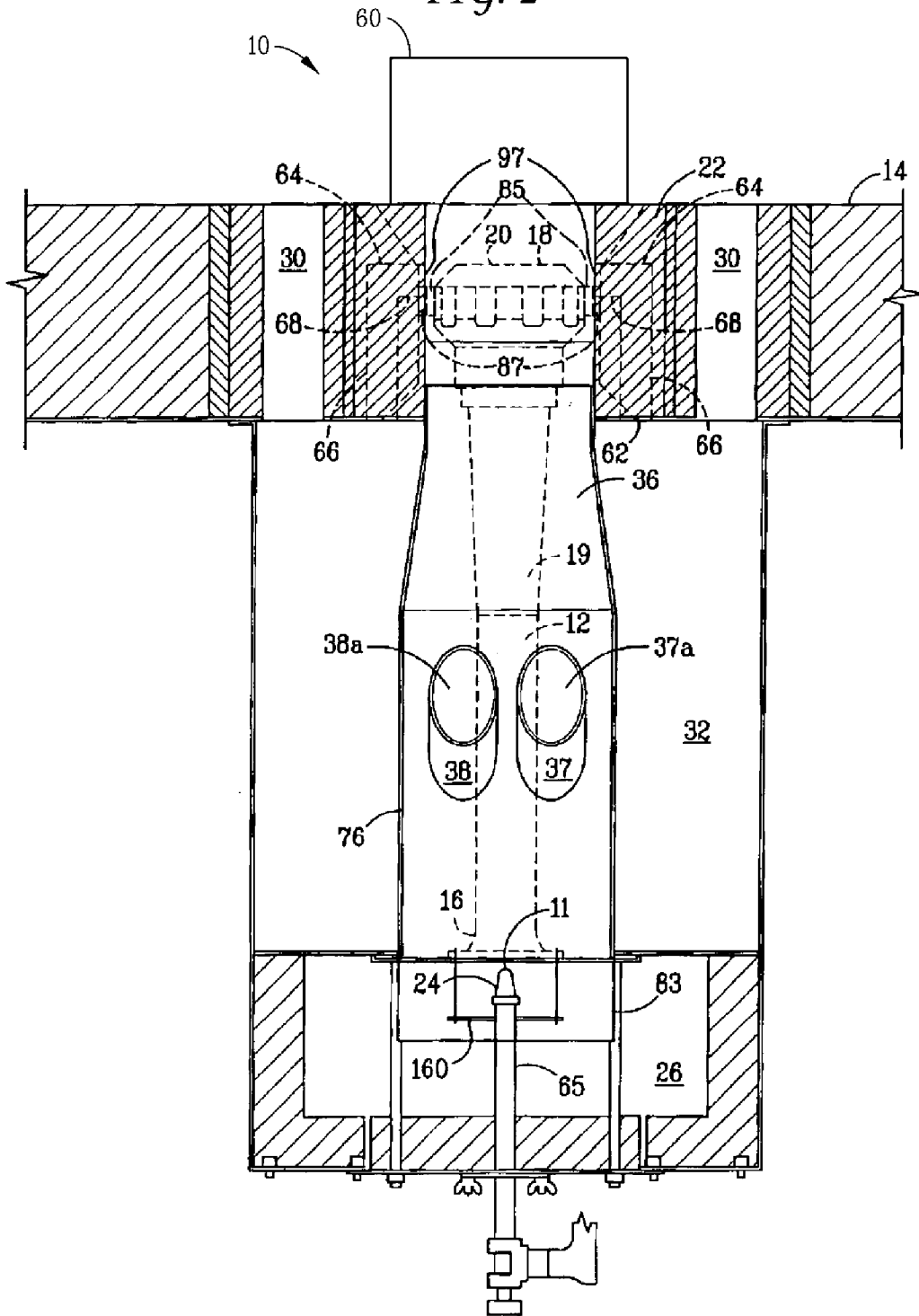

FIG. 3

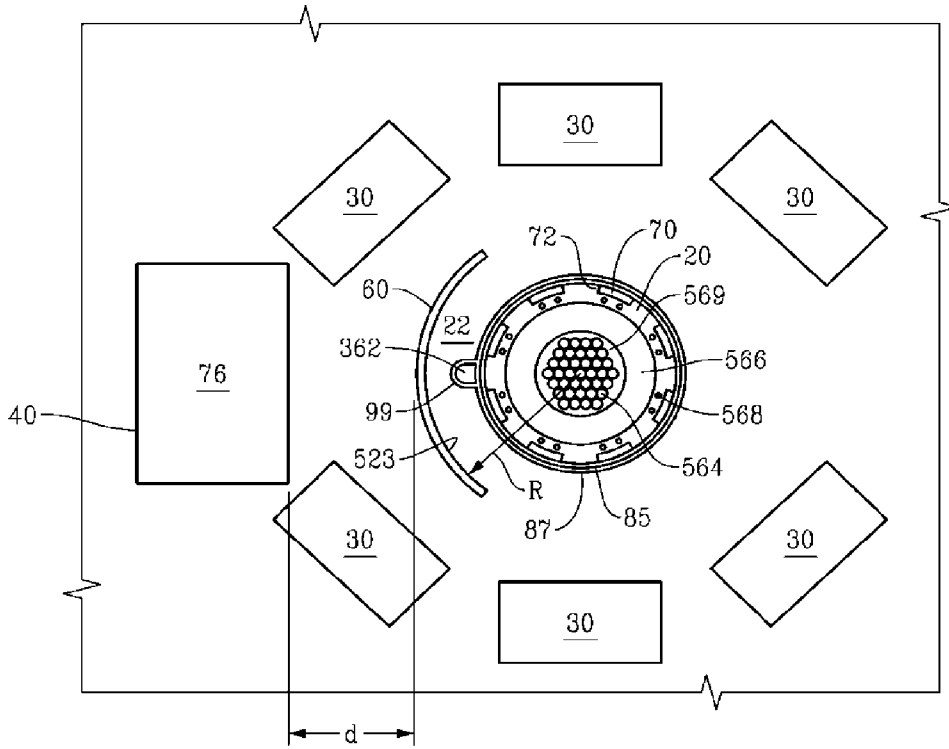

FIG. 4

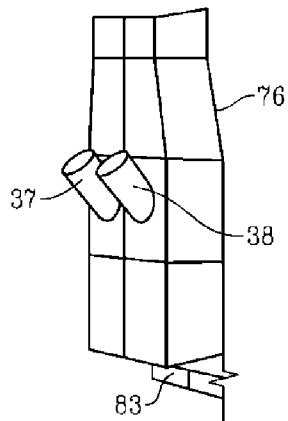

FIG. 5

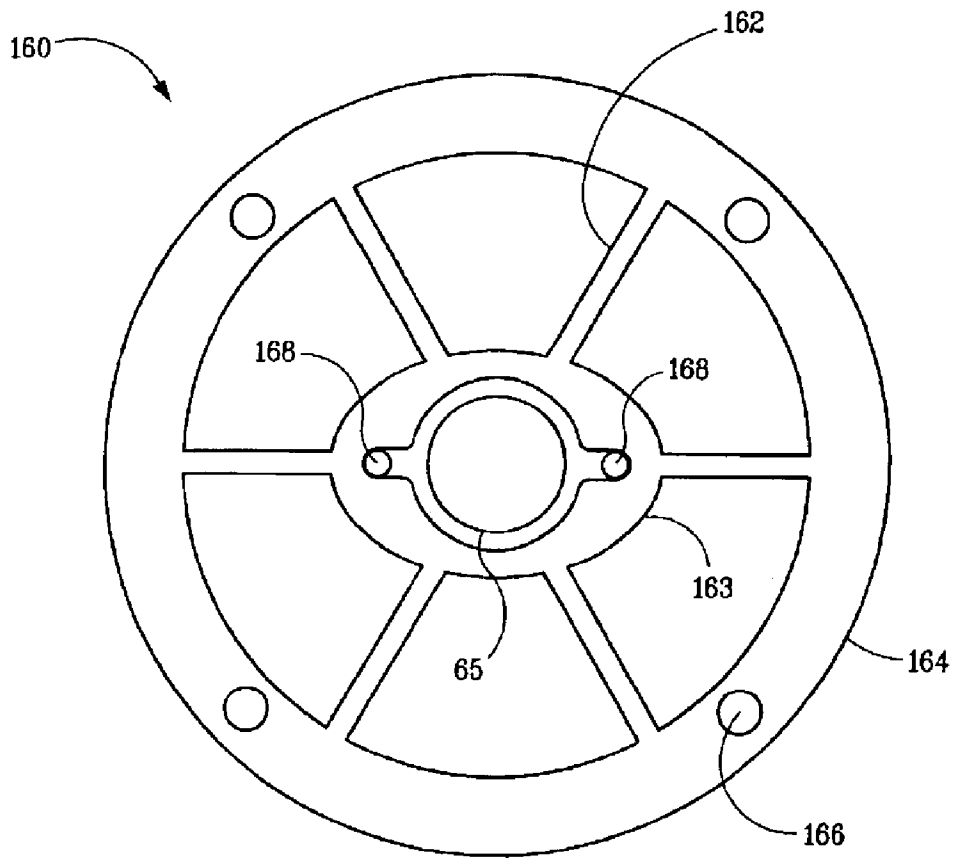

FIG. 6A

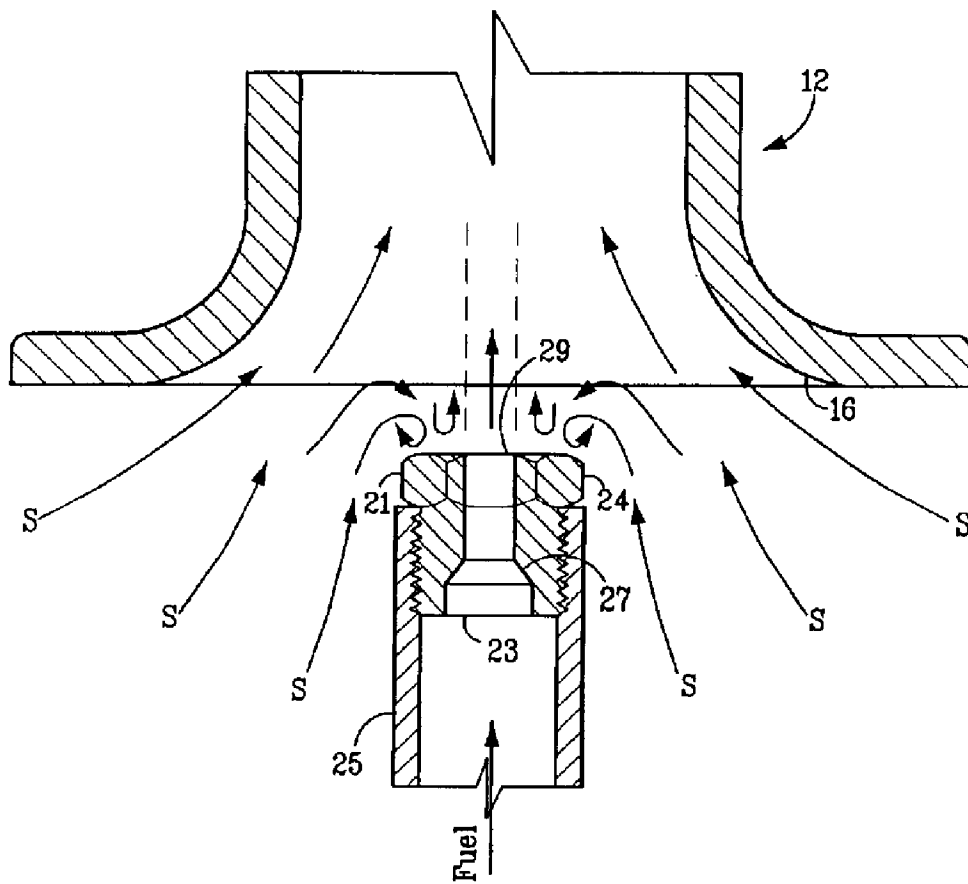

FIG. 6B

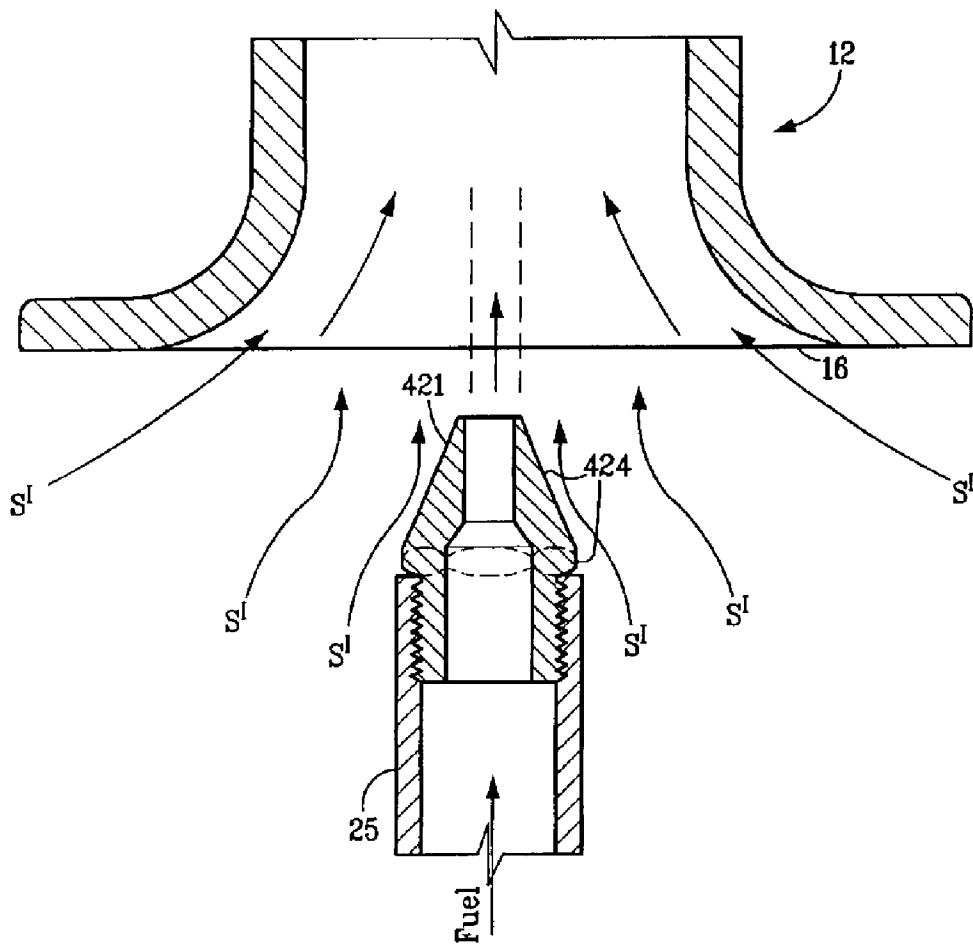

FIG. 7B

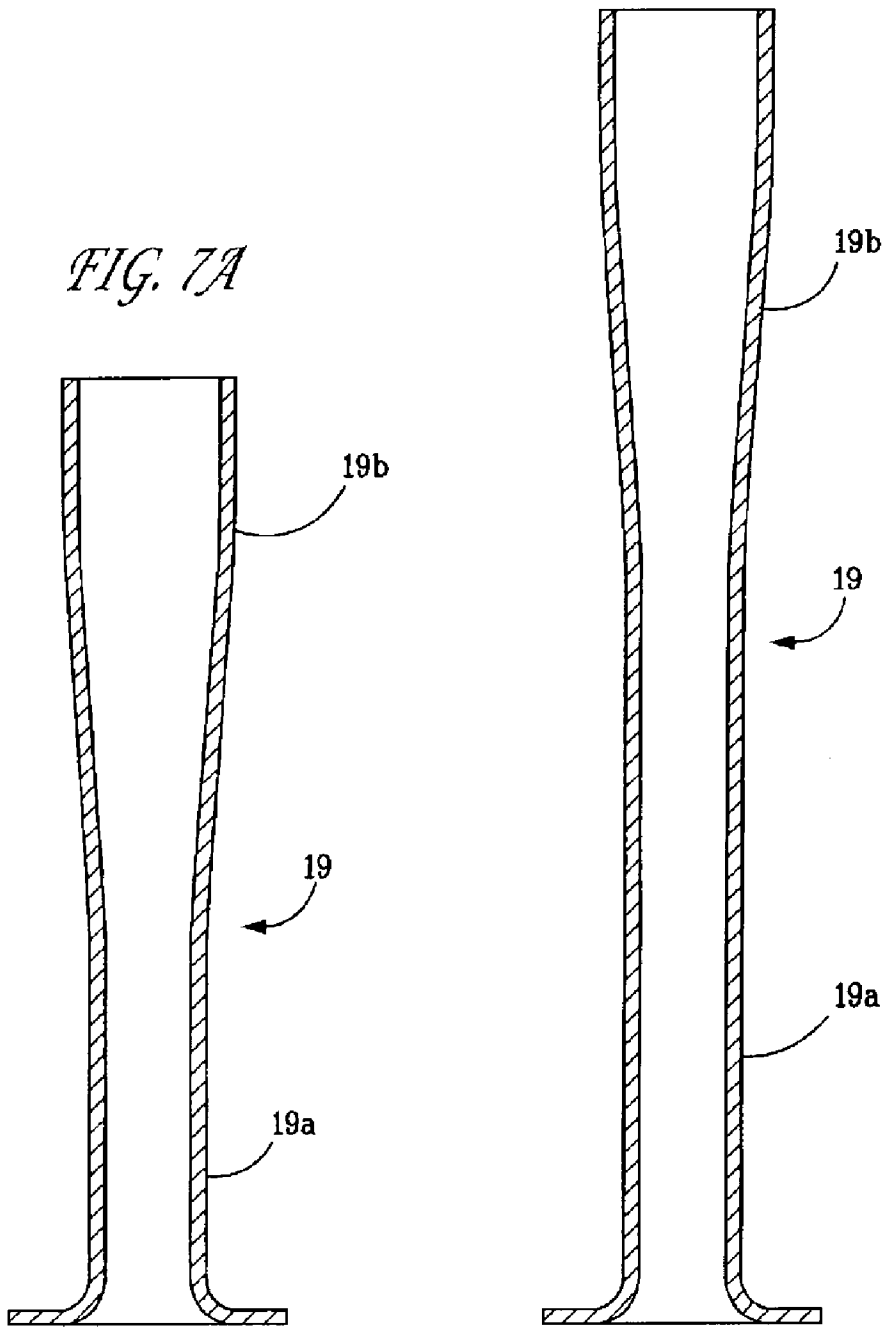
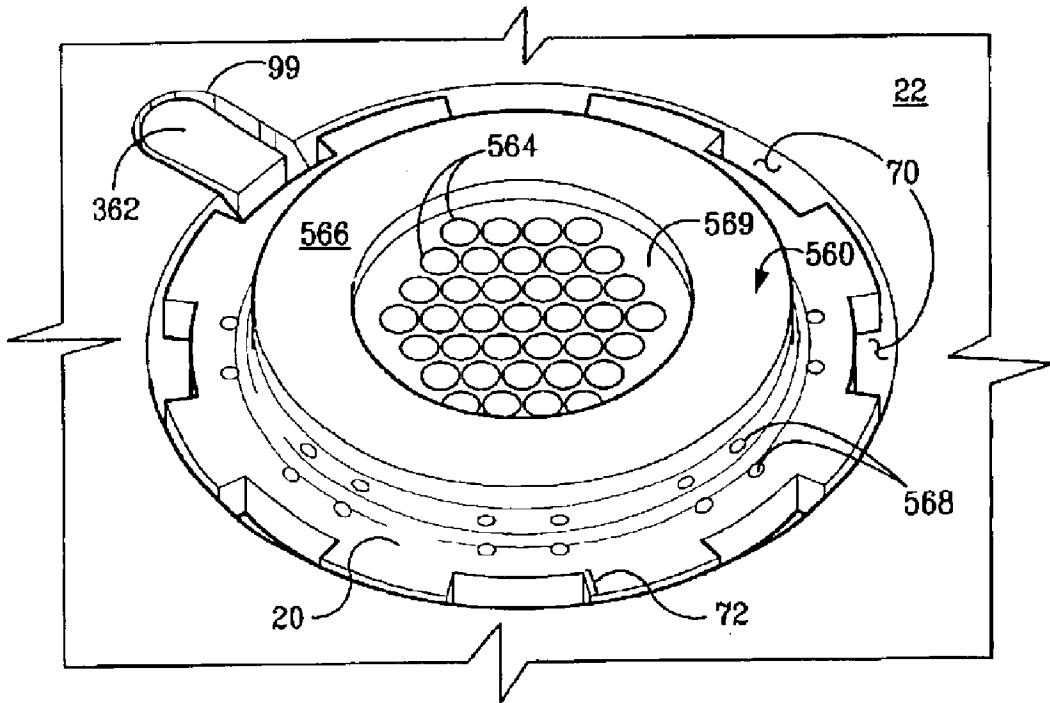
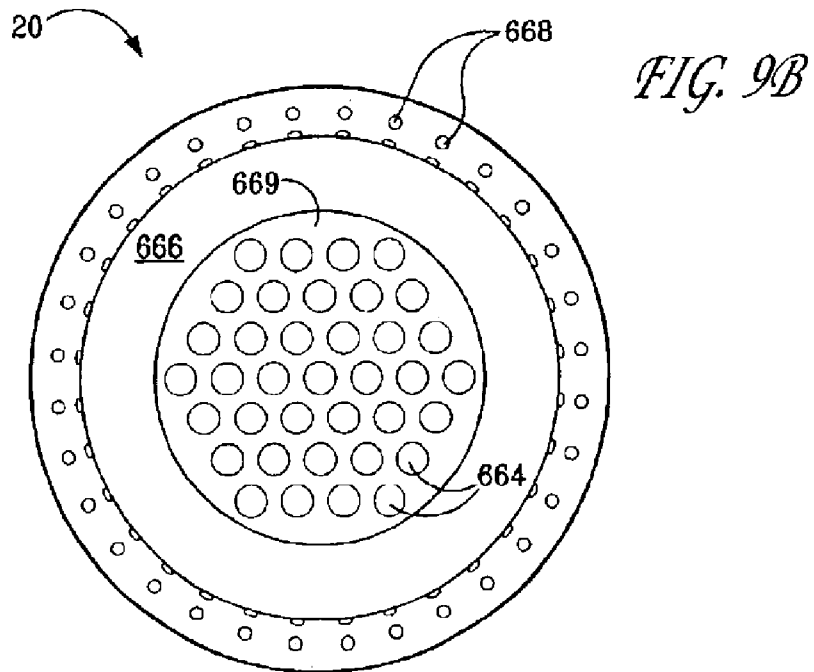
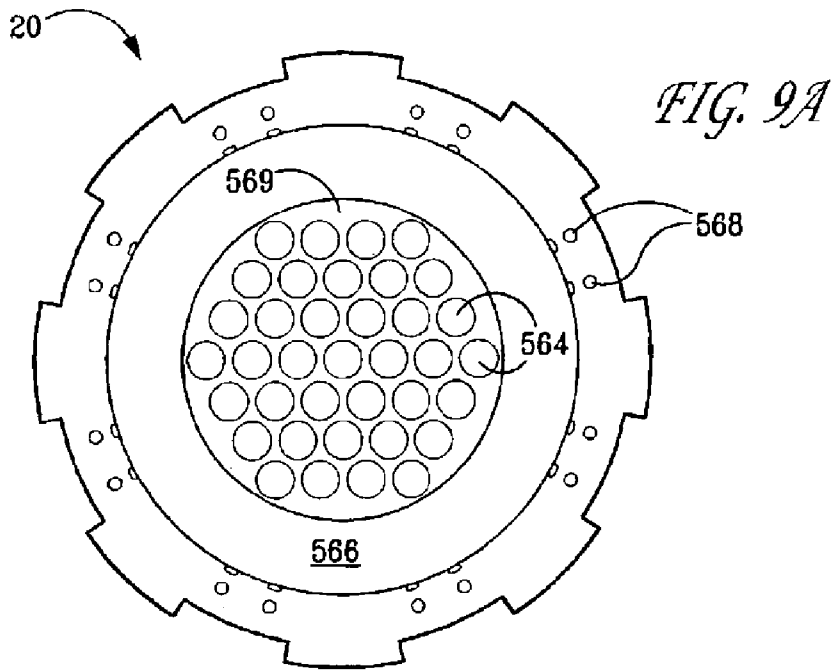

FIG. 8





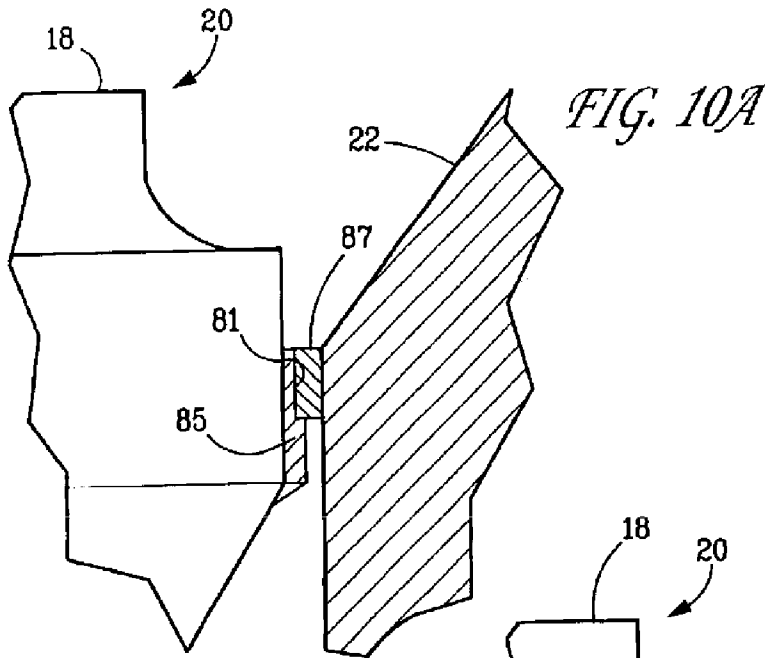

FIG. 10B

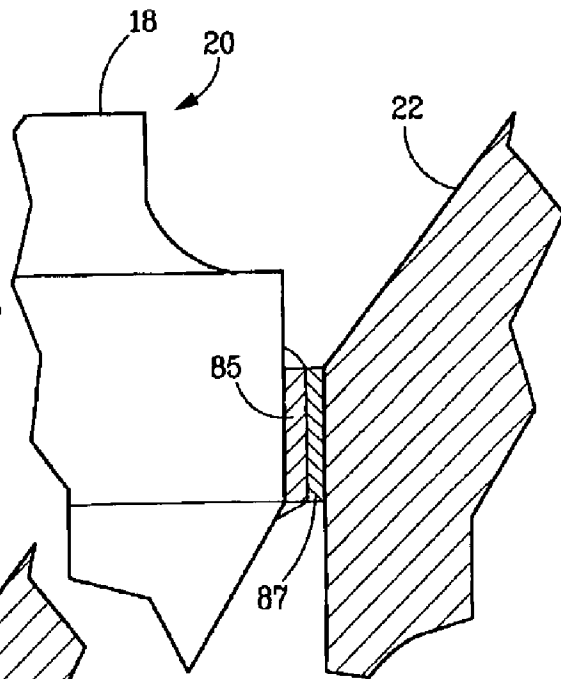

FIG. 10C

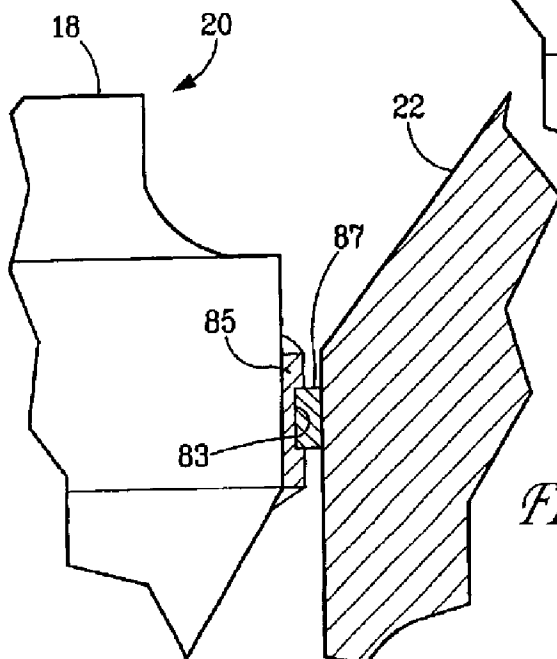

FIG. 11

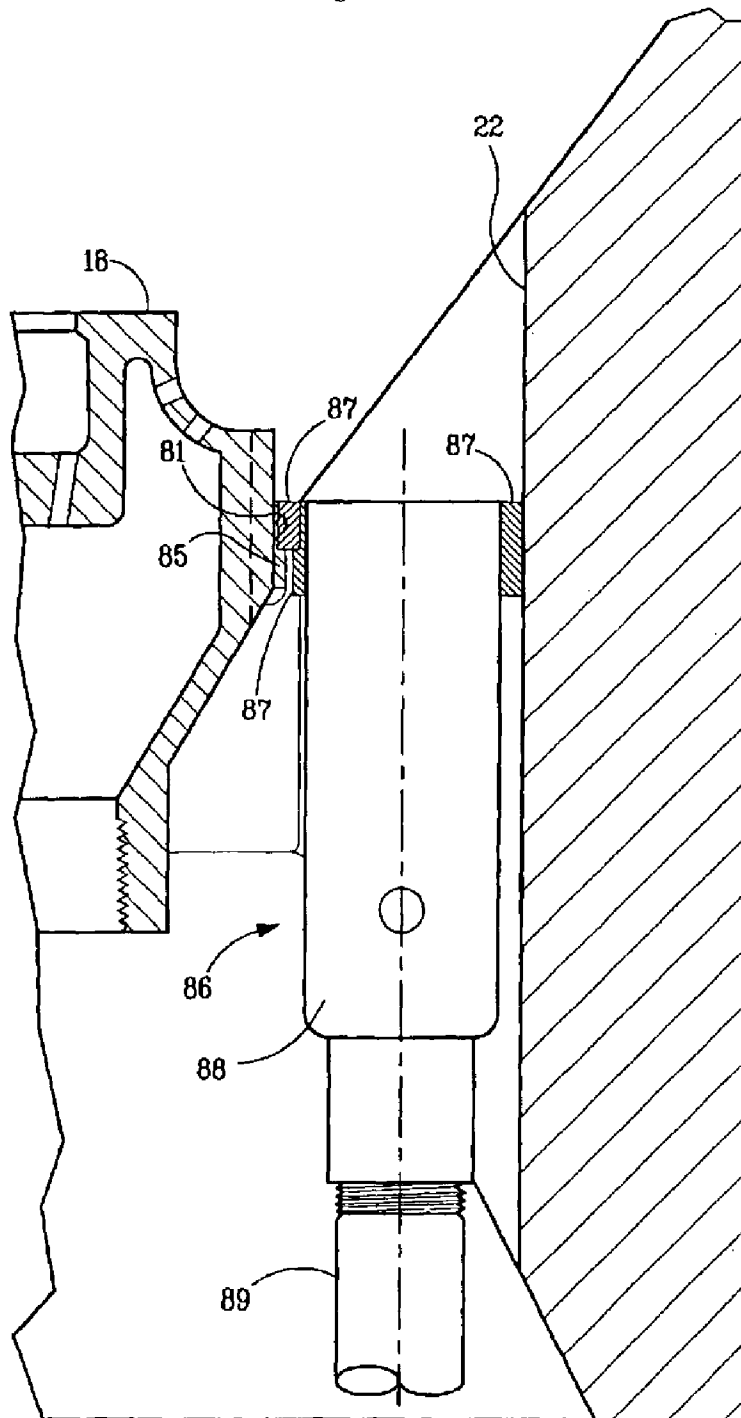

FIG. 12

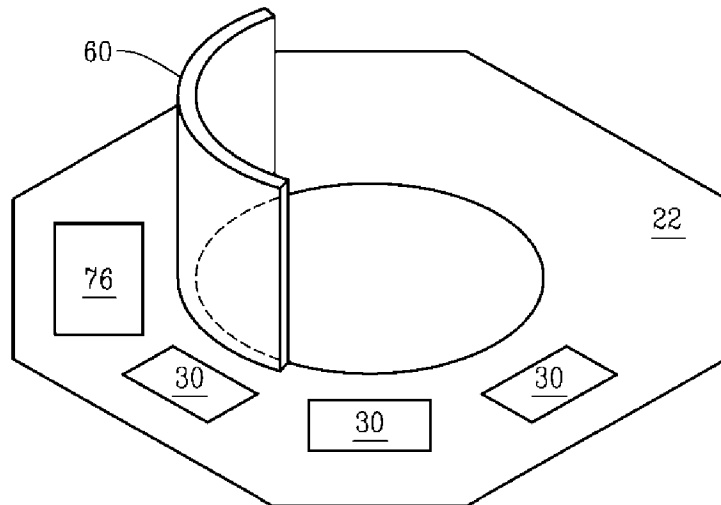

FIG. 12A

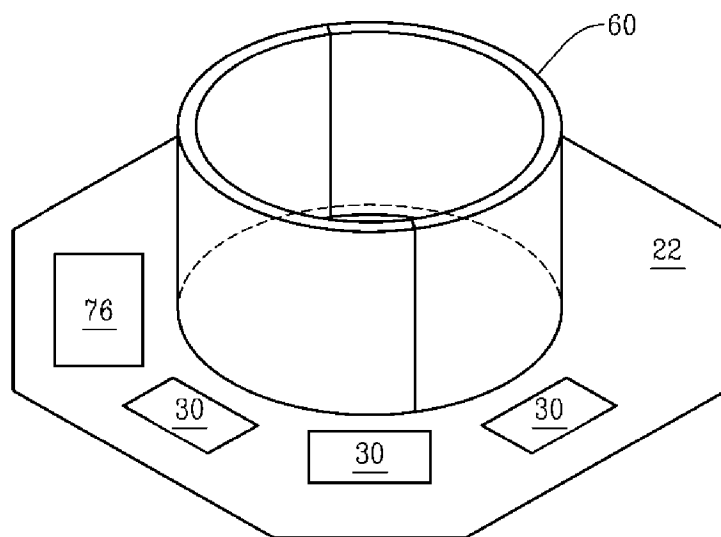

FIG. 13

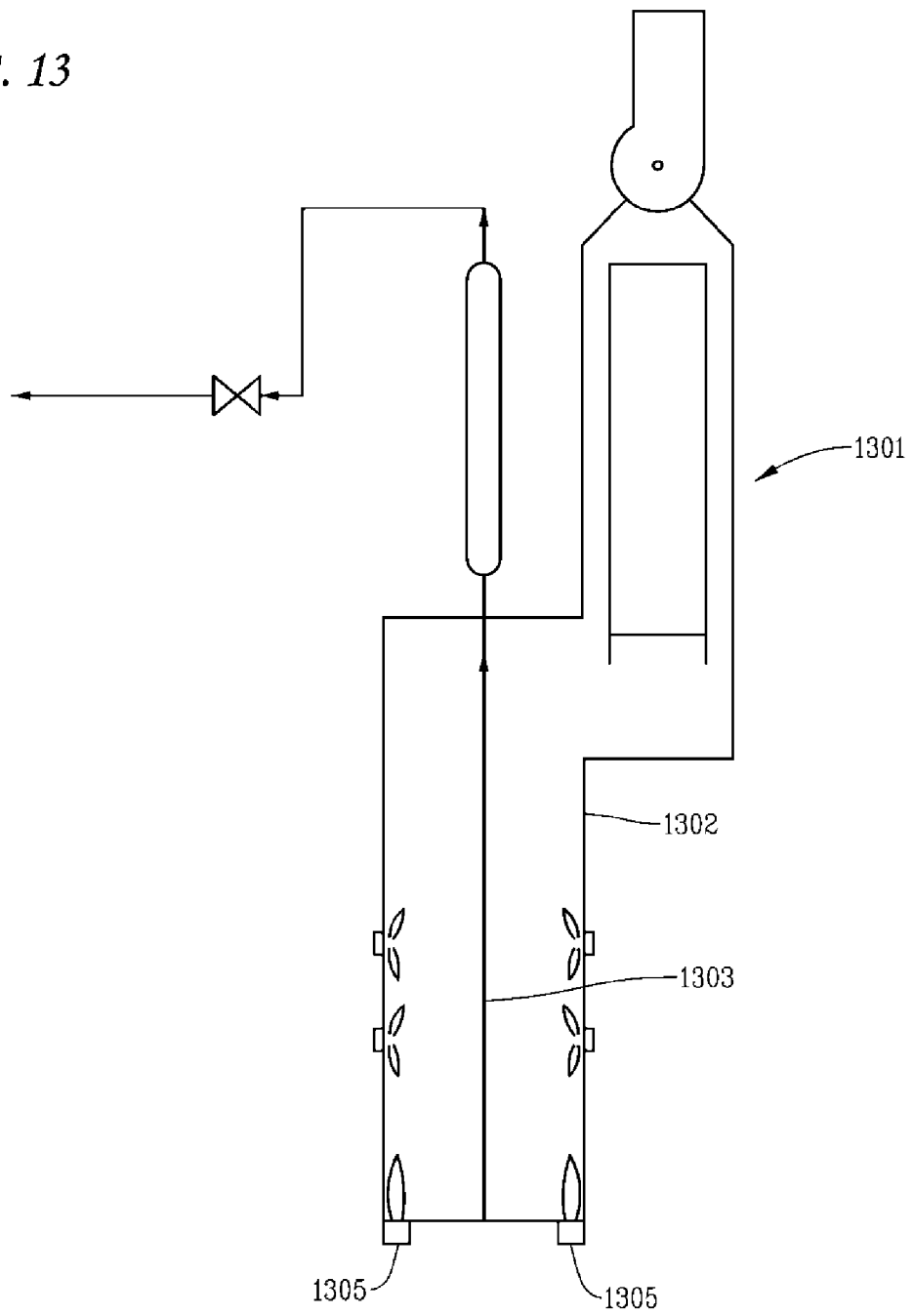
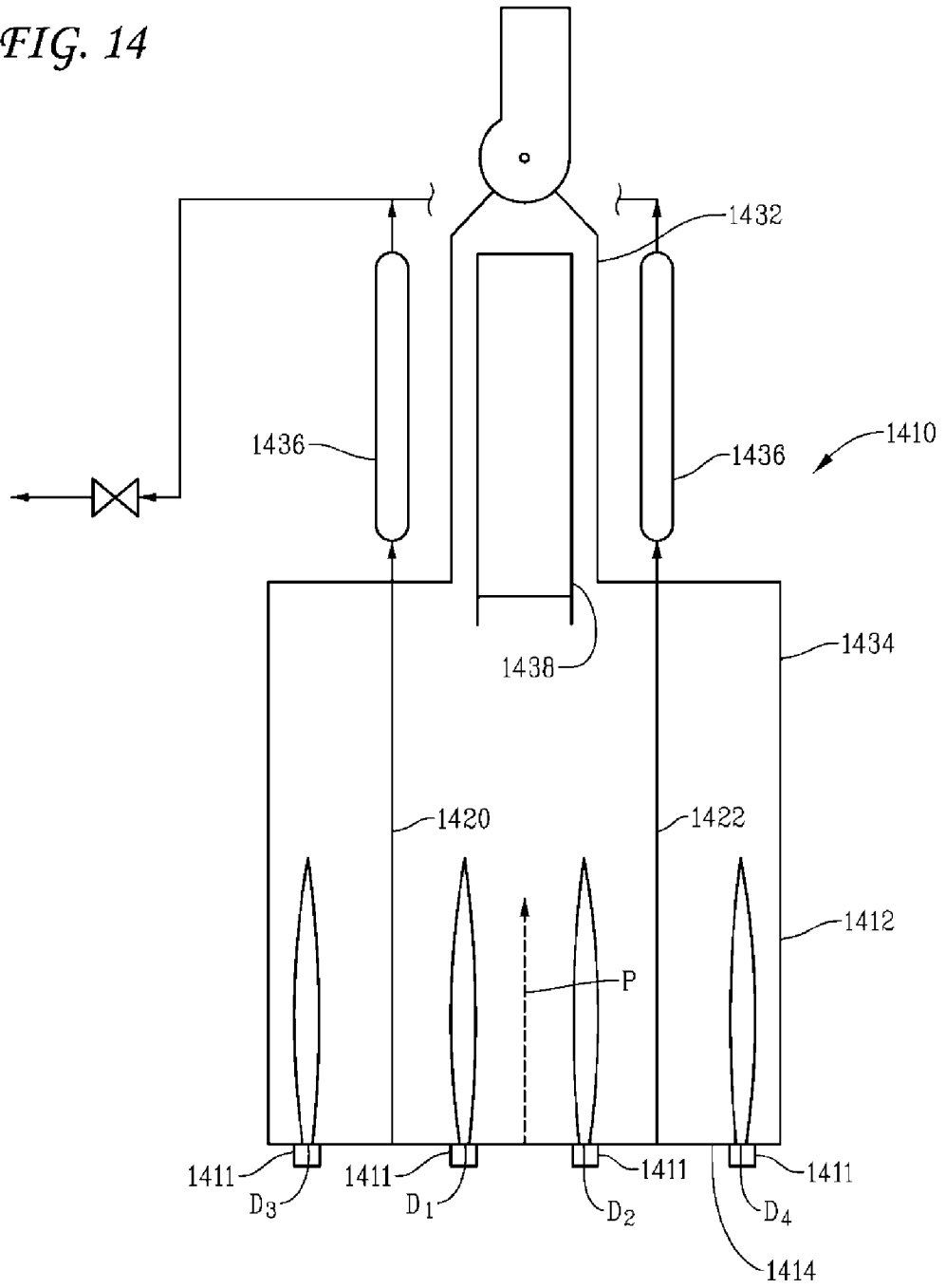

FIG. 14



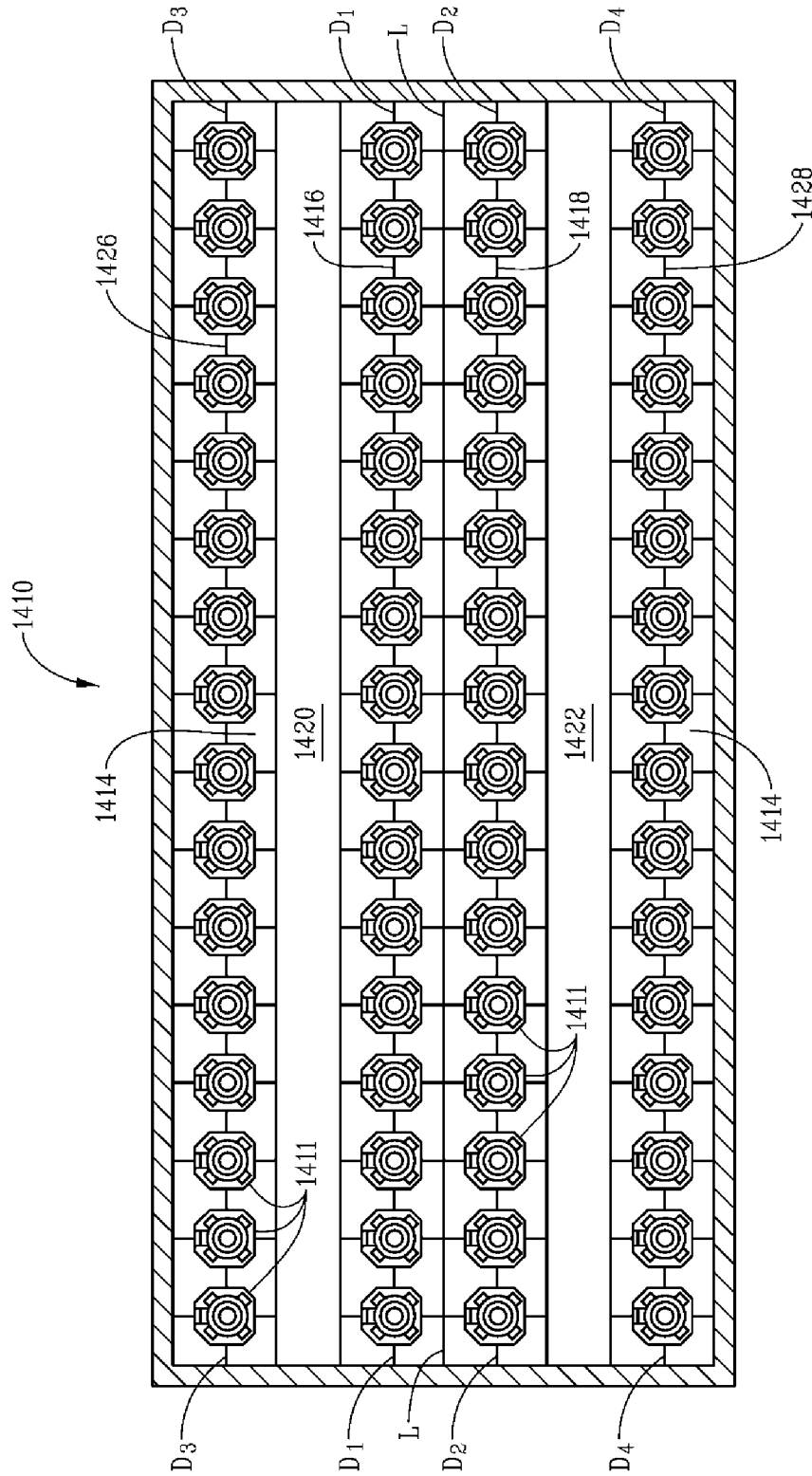

FIG. 15

INTERNATIONAL SEARCH REPORT

International application No
PCT/US2016/066463

A. CLASSIFICATION OF SUBJECT MATTER
INV. F23C9/00 F23D14/08 F23D14/70 F23M5/02 F23C5/00
ADD.
According to International Patent Classification (IPC) or to both national classification and IPC

B. FIELDS SEARCHED
Minimum documentation searched (classification system followed by classification symbols)
F23C F23D F23M

Documentation searched other than minimum documentation to the extent that such documents are included in the fields searched

Electronic data base consulted during the international search (name of data base and, where practicable, search terms used)
EPO-Internal, WPI Data

C. DOCUMENTS CONSIDERED TO BE RELEVANT

Category*	Citation of document, with indication, where appropriate, of the relevant passages	Relevant to claim No.
X	US 2003/175641 A1 (STEPHENS GEORGE [US] ET AL) 18 September 2003 (2003-09-18)	1-15
Y	column 3, line 31	16-25
Y	column 5, line 17 - line 29; figures 1-5	
Y	----- E Charles: "Burner Design" In: "Industrial Burners", 31 December 2004 (2004-12-31), CRC Press, XP055353507, pages 532-535,	16-18
A	the whole document	22-24
Y	----- US 5 044 932 A (MARTIN MICHAEL J [US] ET AL) 3 September 1991 (1991-09-03)	19-25
A	column 5, line 54 - column 6, line 38; figure 3; example 4	1-15
	----- -/--	

Further documents are listed in the continuation of Box C.

See patent family annex.

* Special categories of cited documents :

- "A" document defining the general state of the art which is not considered to be of particular relevance
- "E" earlier application or patent but published on or after the international filing date
- "L" document which may throw doubts on priority claim(s) or which is cited to establish the publication date of another citation or other special reason (as specified)
- "O" document referring to an oral disclosure, use, exhibition or other means
- "P" document published prior to the international filing date but later than the priority date claimed

- "T" later document published after the international filing date or priority date and not in conflict with the application but cited to understand the principle or theory underlying the invention
- "X" document of particular relevance; the claimed invention cannot be considered novel or cannot be considered to involve an inventive step when the document is taken alone
- "Y" document of particular relevance; the claimed invention cannot be considered to involve an inventive step when the document is combined with one or more other such documents, such combination being obvious to a person skilled in the art
- "&" document member of the same patent family

Date of the actual completion of the international search 10 March 2017	Date of mailing of the international search report 17/03/2017
--	--

Name and mailing address of the ISA/ European Patent Office, P.B. 5818 Patentlaan 2 NL - 2280 HV Rijswijk Tel. (+31-70) 340-2040, Fax: (+31-70) 340-3016	Authorized officer Harder, Sebastian
--	---

INTERNATIONAL SEARCH REPORT

International application No
PCT/US2016/066463

C(Continuation). DOCUMENTS CONSIDERED TO BE RELEVANT		
Category*	Citation of document, with indication, where appropriate, of the relevant passages	Relevant to claim No.
A	US 6 893 251 B2 (STEPHENS GEORGE [US]) 17 May 2005 (2005-05-17) column 4, line 55 - column 5, line 14 column 7, line 28 - line 32; figures 1-7; examples 1, 2	1-16, 19-25
A	----- US 2004/018461 A1 (STEPHENS GEORGE [US] ET AL) 29 January 2004 (2004-01-29) cited in the application paragraphs [0074], [0089], [0090]; claim 32; figures 1, 2 -----	1-15

INTERNATIONAL SEARCH REPORT

Information on patent family members

International application No

PCT/US2016/066463

Patent document cited in search report	Publication date	Patent family member(s)	Publication date
US 2003175641	A1	18-09-2003	NONE

US 5044932	A	03-09-1991	US 5044932 A 03-09-1991
			US 5316469 A 31-05-1994

US 6893251	B2	17-05-2005	NONE

US 2004018461	A1	29-01-2004	AU 2003225834 A1 08-10-2003
			EP 1495263 A2 12-01-2005
			JP 4264004 B2 13-05-2009
			JP 2005521024 A 14-07-2005
			US 2004018461 A1 29-01-2004
			WO 03081132 A2 02-10-2003
