

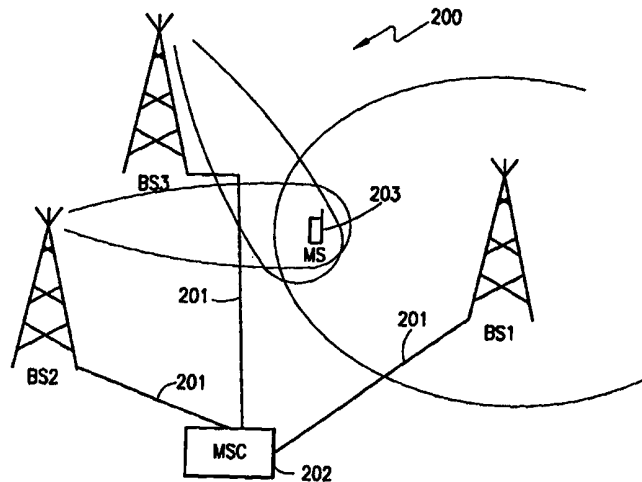

INTERNATIONAL APPLICATION PUBLISHED UNDER THE PATENT COOPERATION TREATY (PCT)

<p>(51) International Patent Classification ⁶ : H04Q 7/38</p>	<p>A1</p>	<p>(11) International Publication Number: WO 99/33304</p> <p>(43) International Publication Date: 1 July 1999 (01.07.99)</p>
<p>(21) International Application Number: PCT/SE98/02174</p> <p>(22) International Filing Date: 27 November 1998 (27.11.98)</p> <p>(30) Priority Data: 08/994,586 19 December 1997 (19.12.97) US</p> <p>(71) Applicant: TELEFONAKTIEBOLAGET LM ERICSSON (publ) [SE/SE]; S-126 25 Stockholm (SE).</p> <p>(72) Inventors: SARA, Mazur; Vikavägen 11, S-167 71 Bromma (SE). BO, Hagerman; Tjärhovsgatan 16, S-116 21 Stockholm (SE).</p> <p>(74) Agent: ERICSSON RADIO SYSTEMS AB; Common Patent Dept., S-164 80 Stockholm (SE).</p>		<p>(81) Designated States: AL, AM, AT, AU, AZ, BA, BB, BG, BR, BY, CA, CH, CN, CU, CZ, DE, DK, EE, ES, FI, GB, GD, GE, GH, GM, HR, HU, ID, IL, IS, JP, KE, KG, KP, KR, KZ, LC, LK, LR, LS, LT, LU, LV, MD, MG, MK, MN, MW, MX, NO, NZ, PL, PT, RO, RU, SD, SE, SG, SI, SK, SL, TJ, TM, TR, TT, UA, UG, UZ, VN, YU, ZW, ARIPO patent (GH, GM, KE, LS, MW, SD, SZ, UG, ZW), Eurasian patent (AM, AZ, BY, KG, KZ, MD, RU, TJ, TM), European patent (AT, BE, CH, CY, DE, DK, ES, FI, FR, GB, GR, IE, IT, LU, MC, NL, PT, SE), OAPI patent (BF, BJ, CF, CG, CI, CM, GA, GN, GW, ML, MR, NE, SN, TD, TG).</p> <p>Published <i>With international search report.</i></p>

(54) Title: METHOD AND SYSTEM FOR IMPROVING HANDOFFS IN CELLULAR MOBILE RADIO SYSTEMS



(57) Abstract

A method (300) and system (200, 400) are disclosed for making inter-cell handoffs to a cell of a base station (BS2, BS3) including a directional antenna array (401, 413). The handoff algorithm (309) includes taking into account uplink direction of arrival measurements (305) in at least one candidate target base station, made on signals from the mobile radio terminal (203, 417) to its serving base station (BS1), and directly after handoff using a directional narrow lobe from the antenna array. The narrow lobe can be used immediately after the handoff (313) in the radio base stations (BS2, BS3) that have antenna arrays (401, 413), by including the direction (of arrival information) to the mobile radio terminal (203, 417) in the handoff order (311) to the target base station. Also disclosed are a method and system for measuring uplink interference on idle narrow lobe traffic channels (307), and using this information when selecting at handoff a target base station and traffic channel (309).

FOR THE PURPOSES OF INFORMATION ONLY

Codes used to identify States party to the PCT on the front pages of pamphlets publishing international applications under the PCT.

AL	Albania	ES	Spain	LS	Lesotho	SI	Slovenia
AM	Armenia	FI	Finland	LT	Lithuania	SK	Slovakia
AT	Austria	FR	France	LU	Luxembourg	SN	Senegal
AU	Australia	GA	Gabon	LV	Latvia	SZ	Swaziland
AZ	Azerbaijan	GB	United Kingdom	MC	Monaco	TD	Chad
BA	Bosnia and Herzegovina	GE	Georgia	MD	Republic of Moldova	TG	Togo
BB	Barbados	GH	Ghana	MG	Madagascar	TJ	Tajikistan
BE	Belgium	GN	Guinea	MK	The former Yugoslav Republic of Macedonia	TM	Turkmenistan
BF	Burkina Faso	GR	Greece	ML	Mali	TR	Turkey
BG	Bulgaria	HU	Hungary	MN	Mongolia	TT	Trinidad and Tobago
BJ	Benin	IE	Ireland	MR	Mauritania	UA	Ukraine
BR	Brazil	IL	Israel	MW	Malawi	UG	Uganda
BY	Belarus	IS	Iceland	MX	Mexico	US	United States of America
CA	Canada	IT	Italy	NE	Niger	UZ	Uzbekistan
CF	Central African Republic	JP	Japan	NL	Netherlands	VN	Viet Nam
CG	Congo	KE	Kenya	NO	Norway	YU	Yugoslavia
CH	Switzerland	KG	Kyrgyzstan	NZ	New Zealand	ZW	Zimbabwe
CI	Côte d'Ivoire	KP	Democratic People's Republic of Korea	PL	Poland		
CM	Cameroon	KR	Republic of Korea	PT	Portugal		
CN	China	KZ	Kazakstan	RO	Romania		
CU	Cuba	LC	Saint Lucia	RU	Russian Federation		
CZ	Czech Republic	LI	Liechtenstein	SD	Sudan		
DE	Germany	LK	Sri Lanka	SE	Sweden		
DK	Denmark	LR	Liberia	SG	Singapore		
EE	Estonia						

**METHOD AND SYSTEM FOR IMPROVING
HANDOFFS IN CELLULAR MOBILE RADIO SYSTEMS**

5 BACKGROUND OF THE INVENTION

Technical Field of the Invention

The present invention relates in general to the mobile radio communications field and, in particular, to a method and system for improving handoffs of mobile radio terminals between radio base stations.

10 Description of Related Art

In cellular mobile radio systems, the mobile radio terminals (mobile stations or MSs) are allowed to move from one cell to another. Consequently, there is a need to be able to handoff these MSs from the radio base station (BS) of the one cell to the radio BS of the other cell (inter-cell handoff). When a handoff of a MS is to be performed from a serving BS to a target BS, the target BS selection is typically made based on the following three criteria (in descending order of importance): (1) information about the expected increased quality of the connection being considered after the handoff (“own interest” aspect); (2) information about the expected decreased quality of other connections (“courtesy” aspect); and (3) information about the traffic load in the target BSs being considered (“availability” aspect).

20 In this regard, (directional) antenna arrays or “smart antennas” have been introduced into the radio BSs of cellular mobile radio systems, in order to direct narrow transmitting and receiving beams (lobes) from the BSs more precisely toward the MSs being served. The use of these directional narrow beam antennas improves the carrier-to-interference ratio (C/I) in the cellular system, and also increases the system’s traffic handling capacity. As such, a need has arisen to provide an effective handoff technique that takes advantage of the benefits afforded to cellular systems including radio BSs with directional antenna arrays.

25 PCT Application No. PCT/SE95/00764 (WO 96/00484) discloses an intra-cell (within a cell) handoff method based on the use of spatial information measured with an antenna array. Swedish Patent Application No. 9702597-7 (P08214) discloses an intra-cell handoff method used in a radio BS including an array antenna. With these

-2-

approaches, information about the Direction-of-Arrival (DOA) information used for transmissions from the BS before the handoff occurs, is made available by the serving transmitter-receiver to the target transmitter-receiver for use after the handoff occurs. However, a common drawback of these conventional approaches is that they both deal specifically with intra-cell handoffs. Consequently, an improved method is needed for handling inter-cell handoffs when antenna arrays or "smart antennas" are being used.

SUMMARY OF THE INVENTION

The use of array antennas in cellular network radio BSs creates a need during handoffs to select an optimal target radio BS from among a plurality of radio BSs. These radio BSs can utilize omni-directional-antennas, sectored antennas, and array antennas. There is also a concomitant need to be able to select a traffic channel in the target BS.

As such, a problem addressed by the present invention is how to provide measurements for use by a handoff algorithm when a system includes BSs with array antennas. Another problem addressed by the present invention is how to use narrow beams in a target BS immediately after an inter-cell handoff occurs.

It is, therefore, an object of the present invention to provide a method and system for determining well in advance of an inter-cell handoff, the path loss and direction of a narrow beam that will be used for communications after the inter-cell handoff occurs, wherein a target BS for the handoff of a MS is selected from among at least two candidate target BSs, and at least one of candidate target BSs has an array antenna. The resulting measurement information derived can be used in a handoff algorithm to select the target BS and the traffic channel to be used.

It is another object of the present invention to provide a method and system for determining well in advance of an inter-cell handoff, the path loss and direction of a narrow beam that will be used for communications after the inter-cell handoff occurs, wherein the target BS for a handoff of a MS is selected from among at least two candidate target BSs, at least one of the candidate target BSs has an array antenna, and also for determining well in advance (but with a relatively simple technique) the quality of a connection to be expected on a narrow lobe traffic channel in the target BS having the array antenna. The resulting supplementary measurement information can

-3-

be used in a handoff algorithm to select the target BS and the traffic channel to be used. (Note: Path loss is equal to transmitted signal strength minus received signal strength. Since the MS's transmitted signal strength is known to the system, the term "path loss" is not referred to hereinafter and instead in the BS received signal strength is used.)

It is still another object of the present invention to provide a method and system that enables the use of a narrow beam traffic channel in the target BS immediately after an inter-cell handoff has occurred.

The foregoing and other objects are achieved by a method and system for improved inter-cell handoffs, wherein at least one target BS including an array antenna is equipped with a Modified Receiver Module (ModRX). The ModRX is ordered to perform measurements on a MS served by a neighbor BS. The measurements include at least DOA information and uplink received signal strength (SS-ur) information. The ModRX reports the measurement information to the network controller, which can decide to handoff the MS to a specific traffic channel in a target BS based in part on the measurement information reported by the ModRX.

In one embodiment of the present invention, the DOA and SS-ur measurement information are supplemented by quality measurements made in the ModRX of the target BSs with respect to one or more idle (candidate BSs') traffic channels having the same DOA as the measured DOA of the MS to be handed off (e.g., a common lobe). For example, these quality measurements preferably comprise the uplink received signal strength of the interference (SS-ur-i) in the idle candidate BSs' traffic channels. The SS-ur from the MS, and the SS-ur-i of the idle candidate(s) are then used together with the known uplink transmitted signal strength (SS-ut) of the MS as an input to the handoff algorithm to be used for selecting a target BS and traffic channel.

In a second embodiment of the present invention, the DOA measured and reported by the ModRX is used by the network controller after a handoff decision has been made, to order the target BS to transmit in the direction (from the DOA information) reported by the ModRX.

An important technical advantage of the present invention is that by reporting the DOA information about the MS to be handed off, and the interference of the

-4-

possible narrow lobe target traffic channels in the same DOA, the network controller can use a simple handoff algorithm to choose between narrow lobe and wide lobe traffic channel alternatives for all types of BSs using comparable criteria, such as, for example, the C/I.

5 Another important technical advantage of the present invention is that the handoff method that can be used allows the use of a narrow lobe immediately after the handoff, rather than the conventional approach that first uses a wide lobe in the target BS, finds the (new) DOA in the target BS, and then uses a narrow lobe.

10 Still another important technical advantage of the present invention is that the handoff method used identifies the best narrow lobe DOA information from the MS to be handed off to the target BS, even if a reflected beam is the best beam to use.

15 Yet another important technical advantage of the present invention is that certain popular mobile communications systems, such as, for example, the Ericsson CMS 88 mobile communications system includes modules in the BSs that are capable of measuring SS-ur while performing a "verification" before handoff (i.e., checking SS-ur in the target BS). As such, the specialized ModRX can be a modification of an existing measurement module that, for example, adds a DOA measurement device to an existing measurement module. Consequently, the procedures and signal protocols necessary to perform the DOA and other measurements are already available in the existing module.

20

BRIEF DESCRIPTION OF THE DRAWINGS

A more complete understanding of the method and apparatus of the present invention may be had by reference to the following detailed description when taken in conjunction with the accompanying drawings wherein:

25 FIGURE 1 is a schematic diagram that illustrates a conventional intra-cell handoff wherein the DOA information is immediately reused by the new traffic channel;

30 FIGURE 2 is a schematic diagram of an exemplary mobile radio system that can be used to illustrate an inter-cell handoff, in accordance with a preferred embodiment of the present invention;

-5-

FIGURE 3 is a flow diagram of an exemplary inter-cell handoff method that can be used to implement the preferred embodiment of the present invention as shown in FIGURE 2; and

5 FIGURE 4 is a schematic diagram of the details for the exemplary mobile radio system shown in FIGURE 2.

DETAILED DESCRIPTION OF THE DRAWINGS

The preferred embodiment of the present invention and its advantages are best understood by referring to FIGURES 1-4 of the drawings, like numerals being used for like and corresponding parts of the various drawings.

10 Essentially, the present invention provides an inter-cell handoff method that is based on a verification procedure developed by Ericsson, which can be applied in conjunction with handoffs for the IS-54, IS-136 and Pacific Digital Cellular (PDC) standards. As such, in Ericsson mobile communication systems, when a handoff request is sent to a mobile services switching center (MSC), the MSC selects a target cell and orders a module in the target cell's BS to perform a verification procedure. In the Ericsson systems, such a module is called a Location and Verification Module (LVM) under the IS-136 standard, and a Verification Receiver (VRX) in the PDC standard. The primary purpose of this verification function is to verify the presence of the MS in the target cell. The
15 verification module tunes to and verifies the MS's presence on the old channel (prior to handoff). The verification results are then sent to the MSC.

In accordance with the present invention, the verifying "uplink" measurements carried out by a candidate target BS (candidate to receive the MS being handed off) include DOA measurements in addition to the usual SS measurements. These SS and
25 DOA measurements are reported to the MSC by at least two candidate target BSs, in order to enable the MSC to select an optimal target BS and traffic channel. The DOA information is also used immediately after the handoff for facilitating transmission of a directional downlink narrow lobe. The selection of a narrow lobe traffic channel can be based on DOA information only. Alternatively, the selection of a narrow lobe traffic channel can be based on both DOA information and uplink measurements of
30 quality (e.g., disturbance "I") made on idle traffic channels in the candidate target BSs

-6-

using a narrow uplink beam in the DOA that has been determined for the MS. This information can be obtained by measurements performed before handoff (e.g., event-driven), or performed and collected on a regular basis (periodically).

FIGURE 1 is a schematic diagram that illustrates a conventional intra-cell handoff approach, wherein the DOA information is immediately reused by the new traffic channel. A radio base station BS0 is connected to an MSC 101 via a wireline connection 102. The radio base station BS0 includes an array antenna and a plurality of transceiver modules (TRXs) (not explicitly shown). A mobile radio terminal (MS) is handed off by an intra-cell handoff procedure from one TRX to another TRX in the same radio base station BS0. The radio base station BS0 transmission is indicated in FIGURE 1 by the narrow lobes 103 and 105, which both have the same DOA. The DOA information is made available from one TRX to the other, by storing and updating the information in a memory location in the radio base station BS0.

FIGURE 2 is a schematic diagram of an exemplary mobile radio system 200 that can be used to illustrate an inter-cell handoff, in accordance with a preferred embodiment of the present invention. The mobile radio system 200 includes a plurality of radio base stations. Although three such radio base stations (e.g., BS1, BS2 and BS3) are shown, more than three such radio base stations (e.g., BS1... BS_n) can be included in system 200. The radio base stations shown are connected to a wire-bound network via communication links 201. The wire-bound network can include, for example, an MSC 202. In this embodiment, a mobile radio terminal MS 203 is shown being handed off from radio base station BS1 to one of the other radio base stations BS2 or BS3.

FIGURE 3 is a flow diagram of an exemplary inter-cell handoff method that can be used to implement the preferred embodiment of the present invention in the mobile radio system 200 shown in FIGURE 2. At step 301, the mobile radio terminal MS 203 is located at the periphery of a cell served by radio base station BS1. For this embodiment, radio base station BS1 includes an omni-directional antenna. At this point in time, assume that the mobile radio terminal MS 203 has already performed downlink measurements of signals received from neighboring base stations, and reported the results to the MSC 202 by following a procedure commonly referred to as a Mobile Assisted Handoff (MAHO).

-7-

At step 303, the MSC 202 decides (based on certain criteria including the MAHO measurement results) that it is desirable to handoff the mobile radio terminal MS 203 to one of the plurality of radio base stations BS_n (e.g., BS2 or BS3).

At step 305, the MSC 202 orders the radio base stations BS2 and BS3 to report
5 their respective SS and DOA information as measured on the uplink signals transmitted from the mobile radio terminal MS 203 on its traffic channel to its serving radio base station BS1. Preferably, the parameters of the traffic channel (e.g., frequency, time slot) are indicated in the order message. These measurements can be made in the radio base stations BS2, BS3 by determining their respective DOAs using
10 a conventional approach, measuring the respective uplink received signal strengths (SS-ur), and then reporting the respective DOA and SS-ur information to the MSC 202.

At step 307, the interference (I) (i.e., the received signal strength SS-ur-i received on idle traffic channels) is also reported to the MSC 202. The retrieval of this
15 information can be either event-driven when a handoff is imminent, or periodically reported to the MSC 202 for all channels and/or DOAs.

At step 309, the handoff algorithm being executed in the MSC 202 selects a target radio base station (e.g., BS2 or BS3) and a traffic channel (TCH) to be used for the handoff. This selection is based on the reported information, including at least the
20 DOA, SS-ur, and SS-ur-i for one candidate traffic channel.

At step 311, the MSC 202 sends a handoff order to the selected radio base station (e.g., BS2). The handoff order message includes the DOA information for that radio base station, or alternatively, a reference to the DOA previously reported (which can be stored for a predetermined time in the radio base station BS2).

At step 313, the handoff order is executed, which includes directing a narrow beam TCH downlink towards the handed off mobile radio terminal MS 203, in the direction specified by the DOA information in the handoff order.
25

FIGURE 4 is a schematic diagram that illustrates the details of the exemplary mobile radio system 200 shown in FIGURE 2. Radio base station BS2 (or BS2...
30 BS_n) includes an antenna array 401, which is operable to spatially direct wide and narrow transmitting and receiving lobes. The control of these antenna operations is specified by the control unit 402, which sends switching commands to the antenna

-8-

switch 403. Radio base station BS2 also includes transmitters TX 405 and receivers RX 406 connected to the antenna switch 403 via a combiner 407 and splitter 408. In accordance with the present invention, a specialized receiver module ModRX 409 performs the uplink SS measurements in an SS measurement device 411, and DOA measurements in a DOA measurement device 412. The SS and DOA measurements are performed using a known approach under the control of the control unit 402, which controls the antenna switch 403 and ModRX 409 along with the SS measurement device 411 and DOA measurement device 412. A second radio base station BS3 is also shown with an antenna array 413. Radio base station BS3 functions and is structured similar to radio base station BS2.

A connection is shown between radio base station BS1 and an MSC 414. The MSC 414 includes a processor 415 and a memory store 416, which can be used to execute the handoff algorithm and provide the appropriate handoff orders to the radio base stations and mobile radio terminal MS 417. In this exemplary embodiment, MS 417 is being handed off from BS1 to BS2.

For a different embodiment (also referring to FIGURE 4), an alternative to using a specialized receiver ModRX for SS and DOA measurements, is to equip at least some of the receivers RX 406 with SS and DOA measurement capabilities, and enable those receivers to tune to frequencies not assigned for traffic with their respective radio base stations (e.g., in this case BS2) in order to make the appropriate measurements.

Although a preferred embodiment of the method and apparatus of the present invention has been illustrated in the accompanying Drawings and described in the foregoing Detailed Description, it will be understood that the invention is not limited to the embodiment disclosed, but is capable of numerous rearrangements, modifications and substitutions without departing from the spirit of the invention as set forth and defined by the following claims.

-9-

WHAT IS CLAIMED IS:

1. A method for performing an inter-cell handoff in a mobile communications system, comprising the steps of:

5 measuring in at least one candidate target base station signal strength and direction of arrival parameters from an uplink signal transmitted by a mobile terminal to a serving radio base station;

reporting said measured signal strength and direction of arrival parameters to a network controller;

10 said network controller selecting a target base station from at least two candidate target base stations, said two candidate target base stations including said at least one candidate target base station, using said measured parameters; and

ordering said selected target base station to complete said handoff of said mobile terminal.

15 2. The method of Claim 1, wherein the ordering step further comprises the steps of:

including said measured direction of arrival parameter in an order message to said target base station; and

20 responsive to said order message, said target base station transmitting immediately after said handoff a narrow lobe in a direction associated with said direction of arrival parameter.

3. The method of Claim 1, wherein the ordering step further comprises the steps of:

including a reference associated with said direction of arrival parameter in an order message to said target base station; and

25 responsive to said order message, said target base station retrieving said direction of arrival parameter and transmitting a narrow lobe in a direction associated with said direction of arrival parameter immediately after said handoff.

-10-

4. The method of Claim 1, wherein the measuring step further comprises the step of measuring interference signal strength on an idle narrow lobe candidate traffic channel in a direction indicated by said direction of arrival parameter.

5. A method for performing an inter-cell handoff in a mobile communication system, comprising the steps of:

measuring in at least one candidate target base station signal strength and direction of arrival parameters from an uplink signal transmitted by a mobile terminal to a serving radio base station;

reporting said signal strength and direction of arrival parameters to a network controller;

determining if said reported signal strength parameter is greater than or equal to a threshold value; and

if said reported signal strength parameter is greater than or equal to said threshold value, ordering said target base station to complete said handoff of said mobile terminal using a narrow lobe with a direction associated with said direction of arrival parameter.

6. A method for performing an inter-cell handoff in a mobile communication system, comprising the steps of:

measuring in at least one candidate target base station signal strength and direction of arrival parameters from an uplink signal transmitted by a mobile terminal to a serving radio base station;

reporting said measured parameters to a network controller;

said network controller selecting a traffic channel from among a plurality of idle traffic channels using said measured parameters; and

ordering a selected target base station to complete said handoff using a narrow lobe in a direction determined from the measuring step.

7. The method of Claim 6, wherein the measuring step further comprises:

-11-

measuring in said at least one candidate target base station an interference signal strength parameter from at least one uplink interference signal in said direction of arrival, on a narrow lobe on an idle traffic channel.

5 8. A system for performing an inter-cell handoff in a mobile communications system, comprising:

a network controller;

at least one candidate target base station including a measurement unit for measuring signal strength and direction of arrival parameters from an uplink signal transmitted by a mobile terminal to a serving radio base station; and

10 means for reporting said measured signal strength and direction of arrival parameters to said network controller, said network controller selecting said target base station using said measured signal strength and direction of arrival parameters, and ordering said selected target base station to complete said handoff of said mobile terminal.

15 9. The system of Claim 8, wherein said measurement unit comprises a modified receiver module.

20 10. The system of Claim 8, wherein said means for ordering comprises means for ordering said selected target base station to complete said handoff of said mobile terminal using a narrow lobe with a direction associated with said reported direction of arrival parameter.

11. A radio base station, comprising:

a directional antenna;

25 means for measuring a direction of arrival and uplink received signal strength associated with a signal transmitted from a radio terminal to a serving radio base station; and

means for reporting to a network controller said measured direction of arrival and uplink received signal strength.

-12-

12. The radio base station of Claim 11, further comprising:
means for measuring a quality of at least one idle traffic channel including a narrow lobe in said direction of arrival; and
means for reporting to said network controller said measured direction of arrival, said measured uplink received signal strength, and said measured quality.
- 5

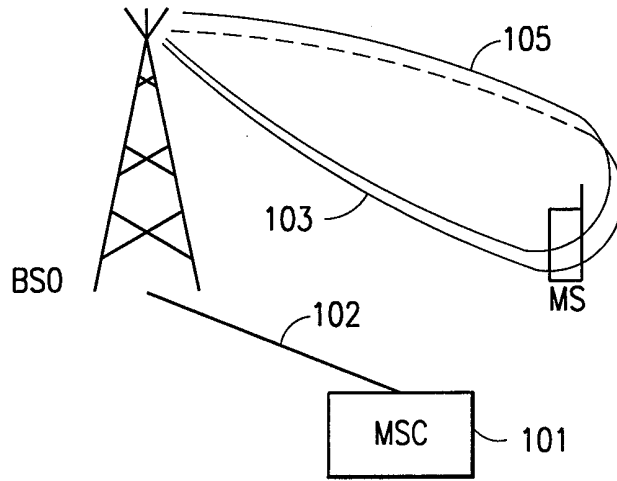

FIG. 1 (PRIOR ART)

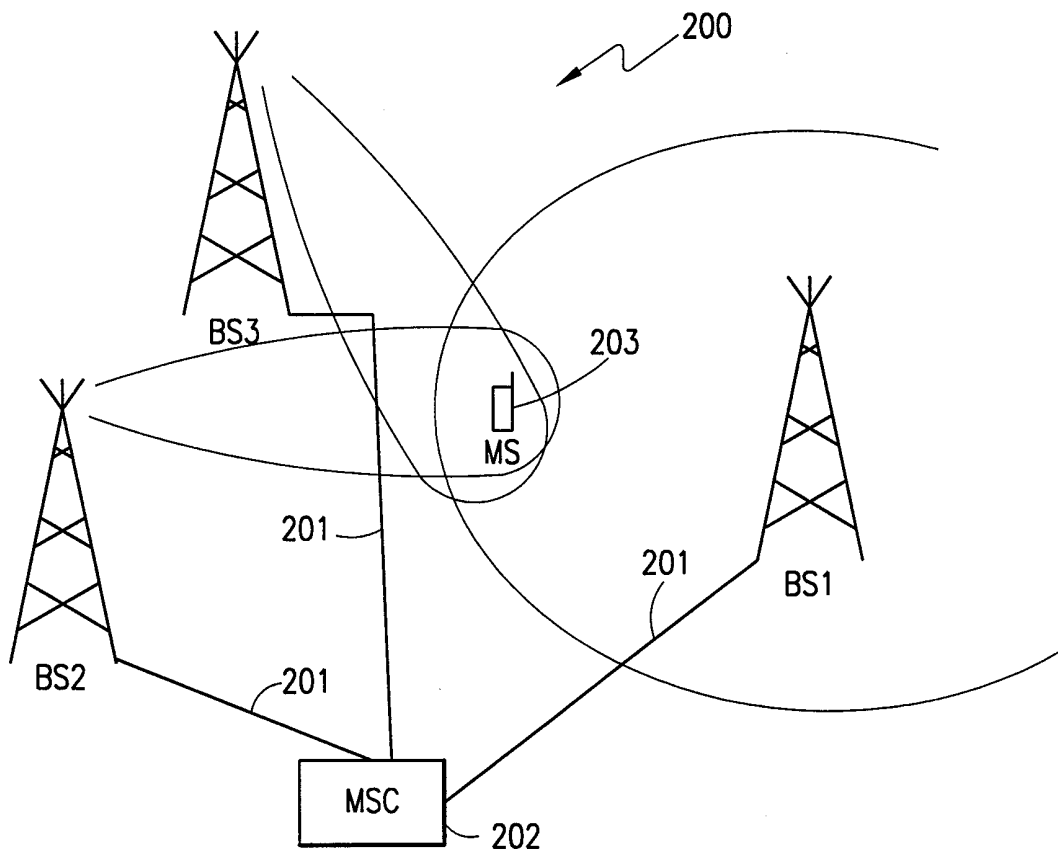

FIG. 2

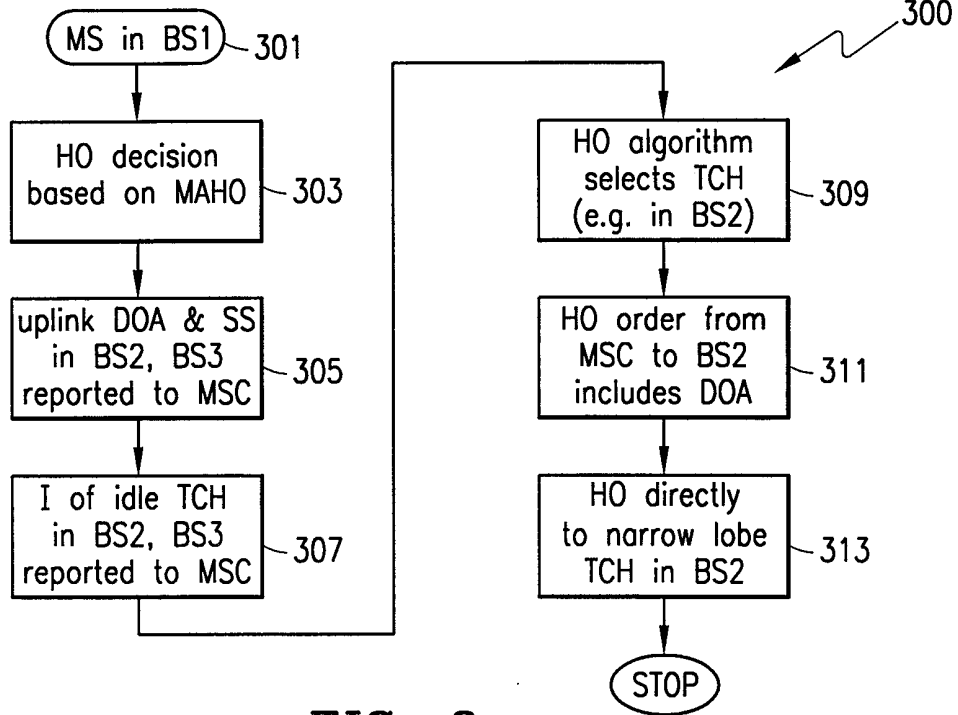

FIG. 3

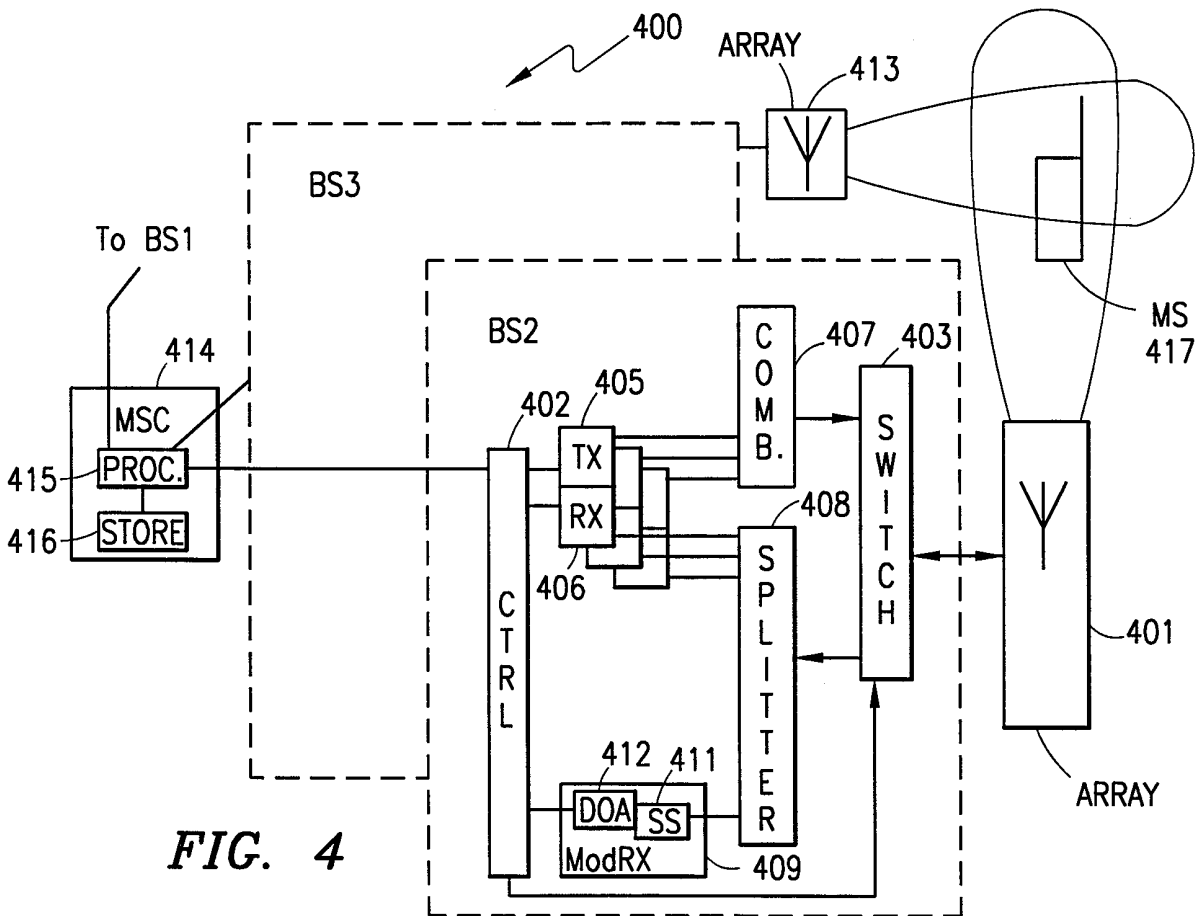

FIG. 4

INTERNATIONAL SEARCH REPORT

International Application No PCT/SE 98/02174
--

A. CLASSIFICATION OF SUBJECT MATTER
 IPC 6 H04Q7/38

According to International Patent Classification (IPC) or to both national classification and IPC

B. FIELDS SEARCHED

Minimum documentation searched (classification system followed by classification symbols)
 IPC 6 H04Q

Documentation searched other than minimum documentation to the extent that such documents are included in the fields searched

Electronic data base consulted during the international search (name of data base and, where practical, search terms used)

C. DOCUMENTS CONSIDERED TO BE RELEVANT

Category °	Citation of document, with indication, where appropriate, of the relevant passages	Relevant to claim No.
A	WO 96 38015 A (NOKIA TELECOMMUNICATIONS OY ;KESKITALO ILKKA (FI); MUSZYNSKI PETER) 28 November 1996	1,5,6,8
X	see page 1, line 4 - page 9, line 30 ---	11
A	WO 96 00484 A (ERICSSON TELEFON AB L M) 4 January 1996 cited in the application see page 1, line 7 - page 4, line 11 ---	1,5,6,8, 11
A	EP 0 659 028 A (NIPPON ELECTRIC CO) 21 June 1995 see column 4, line 10 - column 8, line 58 ---	1,5,6,8, 11
A	EP 0 639 035 A (NORTHERN TELECOM LTD) 15 February 1995 see column 9, line 28 - column 10, line 31; figure 9 ---	1,5,6,8, 11

	-/--	

<input checked="" type="checkbox"/> Further documents are listed in the continuation of box C.	<input checked="" type="checkbox"/> Patent family members are listed in annex.
--	--

° Special categories of cited documents :

<p>"A" document defining the general state of the art which is not considered to be of particular relevance</p> <p>"E" earlier document but published on or after the international filing date</p> <p>"L" document which may throw doubts on priority claim(s) or which is cited to establish the publication date of another citation or other special reason (as specified)</p> <p>"O" document referring to an oral disclosure, use, exhibition or other means</p> <p>"P" document published prior to the international filing date but later than the priority date claimed</p>	<p>"T" later document published after the international filing date or priority date and not in conflict with the application but cited to understand the principle or theory underlying the invention</p> <p>"X" document of particular relevance; the claimed invention cannot be considered novel or cannot be considered to involve an inventive step when the document is taken alone</p> <p>"Y" document of particular relevance; the claimed invention cannot be considered to involve an inventive step when the document is combined with one or more other such documents, such combination being obvious to a person skilled in the art.</p> <p>"&" document member of the same patent family</p>
--	--

Date of the actual completion of the international search 26 March 1999	Date of mailing of the international search report 06/04/1999
---	---

Name and mailing address of the ISA European Patent Office, P.B. 5818 Patentlaan 2 NL - 2280 HV Rijswijk Tel. (+31-70) 340-2040, Tx. 31 651 epo nl, Fax: (+31-70) 340-3016	Authorized officer Gastaldi, G
--	--

INTERNATIONAL SEARCH REPORT

In tional Application No
PCT/SE 98/02174

C.(Continuation) DOCUMENTS CONSIDERED TO BE RELEVANT		
Category	Citation of document, with indication, where appropriate, of the relevant passages	Relevant to claim No.
A	WO 95 12296 A (QUALCOMM INC) 4 May 1995 see page 1, line 15 - page 7, line 32 -----	1,5,6,8, 11
A	US 4 881 082 A (GRAZIANO VICTOR) 14 November 1989 see column 2, line 36 - line 68 -----	1,5,6,8, 11

INTERNATIONAL SEARCH REPORT

Information on patent family members

In International Application No

PCT/SE 98/02174

Patent document cited in search report	A	Publication date	Patent family member(s)	Publication date
WO 9638015	A	28-11-1996	FI 952529	A 25-11-1996
			AU 5820796	A 11-12-1996
			CN 1158208	A 27-08-1997
			EP 0772950	A 14-05-1997
			JP 10503911	T 07-04-1998
			NO 970298	A 20-03-1997
WO 9600484	A	04-01-1996	AU 689908	B 09-04-1998
			AU 2760695	A 19-01-1996
			CA 2193622	A 04-01-1996
			EP 0766901	A 09-04-1997
			FI 965160	A 18-02-1997
			JP 10502231	T 24-02-1998
US 5848358	A 08-12-1998			
EP 0659028	A	21-06-1995	JP 2556279	B 20-11-1996
			JP 7170561	A 04-07-1995
			US 5566355	A 15-10-1996
EP 0639035	A	15-02-1995	GB 2281007	A 15-02-1995
			GB 2281008	A 15-02-1995
			GB 2281009	A 15-02-1995
			GB 2281010	A 15-02-1995
			GB 2281175	A 22-02-1995
			GB 2281011	A 15-02-1995
			GB 2281012	A 15-02-1995
			GB 2281176	A 22-02-1995
			EP 0647978	A 12-04-1995
			EP 0647979	A 12-04-1995
			EP 0647980	A 12-04-1995
			EP 0647981	A 12-04-1995
			EP 0647982	A 12-04-1995
			EP 0647983	A 12-04-1995
			JP 7079476	A 20-03-1995
			US 5596329	A 21-01-1997
			US 5602555	A 11-02-1997
			US 5570098	A 29-10-1996
			US 5714957	A 03-02-1998
			US 5565873	A 15-10-1996
US 5576717	A 19-11-1996			
US 5666123	A 09-09-1997			
US 5771017	A 23-06-1998			
WO 9512296	A	04-05-1995	AU 699514	B 03-12-1998
			AU 4531497	A 05-02-1998
			AU 686686	B 12-02-1998
			AU 8096494	A 22-05-1995
			BR 9405646	A 26-05-1998
			CA 2150542	A 04-05-1995
			EP 0676119	A 11-10-1995
			FI 953211	A 28-06-1995
			IL 111433	A 16-08-1998
			JP 8508385	T 03-09-1996
			US 5625876	A 29-04-1997
			ZA 9408134	A 13-06-1995
US 4881082	A	14-11-1989	CA 1285030	A 18-06-1991
			JP 1255325	A 12-10-1989