



(11) **EP 4 503 078 A1**

(12) **EUROPEAN PATENT APPLICATION**
published in accordance with Art. 153(4) EPC

(43) Date of publication:
05.02.2025 Bulletin 2025/06

(51) International Patent Classification (IPC):
H01H 9/44 ^(2006.01) **H01H 33/18** ^(2006.01)

(21) Application number: **22935430.3**

(52) Cooperative Patent Classification (CPC):
H01H 9/34; H01H 9/44; H01H 33/08; H01H 33/18

(22) Date of filing: **31.03.2022**

(86) International application number:
PCT/JP2022/016571

(87) International publication number:
WO 2023/188287 (05.10.2023 Gazette 2023/40)

(84) Designated Contracting States:
AL AT BE BG CH CY CZ DE DK EE ES FI FR GB GR HR HU IE IS IT LI LT LU LV MC MK MT NL NO PL PT RO RS SE SI SK SM TR

Designated Extension States:
BA ME

Designated Validation States:
KH MA MD TN

(71) Applicant: **mitsubishi electric corporation**
Chiyoda-ku
Tokyo 100-8310 (JP)

(72) Inventors:
• **ABE, Junichi**
Tokyo 100-8310 (JP)
• **KAGAWA, Koichi**
Tokyo 100-8310 (JP)
• **EDO, Takahiro**
Tokyo 100-8310 (JP)
• **NAKAMURA, Yasunori**
Tokyo 100-8310 (JP)

(74) Representative: **Witte, Weller & Partner**
Patentanwälte mbB
Postfach 10 54 62
70047 Stuttgart (DE)

(54) **OPENING AND CLOSING DEVICE**

(57) An opening and closing device for opening/closing between a first terminal (1a) and a second terminal (1b) arranged so as to face each other includes a first electrode (2a) which is provided at the first terminal and a second electrode (3b) which is provided at the second terminal and driven so as to be separable from the first electrode. The first electrode and the second electrode are brought into contact with each other and kept in a conduction state therebetween, by the attraction force

between magnets (5a, 5b) provided inside each electrode. The conduction between the electrodes is retained by the attraction force between the magnets and a magnetic field is formed around the electrodes, and thus the magnetic field necessary for extinction of an arc (10) generated at the time of opening between the electrodes can be stably provided, so that interruption performance can be improved.

FIG.1

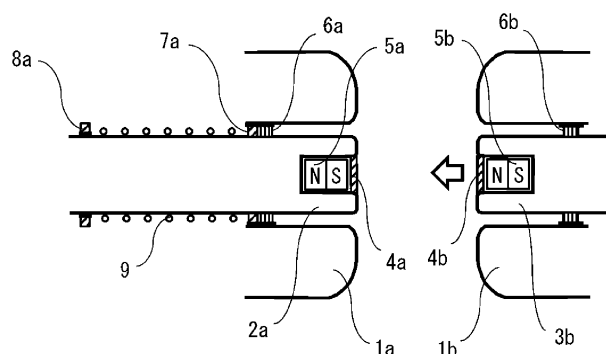

EP 4 503 078 A1

Description

TECHNICAL FIELD

[0001] The present disclosure relates to an opening and closing device which is opened/closed for current.

BACKGROUND ART

[0002] In general, a gas-insulated switchgear includes switches such as a circuit breaker, a disconnecter, and a grounding switch in a container filled with an insulation gas (SF6 gas, dry air, or the like). Each device is required to have a structure with electrodes facing each other and have performance to interrupt an arc that occurs when the electrodes are separated. In addition, it has been known that, when the insulation gas inside the gas-insulated switchgear is SF6 gas having high interruption performance, interruption can be performed by plain break which provides no quick-acting function, but, when the insulation gas is dry air having about 1/100 the interruption performance of SF6 gas, interruption is difficult to be performed. Here, in the plain break, an arc generated when electrodes are separated is elongated by a driving device, to interrupt current.

[0003] As technology for improving current interruption performance, quick break and magnetic driving have been known. The quick break is such a feature that, with a quick-acting mechanism provided at one of electrodes, an opening speed is increased and an arc is elongated to a length needed for arc extinction within a time not causing contact damage, thus obtaining interruption performance. Specifically, in Patent Document 1, a male-side engaging unit and a female-side engaging unit are mechanically connected/disconnected by using a spring such that a quick-acting mechanism can be provided regardless of the tolerance of an installation space, whereby a structure that allows the quick-acting mechanism to be provided on a fixed-side electrode side is achieved. In the magnetic driving, as described in Patent Document 1, a magnet is provided in an opening and closing device, and an arc generated when current is interrupted is magnetically driven and interrupted.

CITATION LIST

PATENT DOCUMENT

[0004] Patent Document 1: Japanese Laid-Open Patent Publication No. 2010-027479

SUMMARY OF THE INVENTION

PROBLEM TO BE SOLVED BY THE INVENTION

[0005] However, in Patent Document 1, since a mechanical engagement mechanism using engaging units is employed, the structure is complicated and the proces-

sing cost and the number of assembly steps are increased, and, furthermore, sliding abrasion due to an increased number of operations causes an engaging failure.

[0006] In addition, in Patent Document 1, the male-side engaging unit and the female-side engaging unit are mechanically connected around the end of a fixed-side terminal, and the fixed-side electrode starts to be moved following a movable-side electrode toward a movable-side terminal disposed so as to face the fixed-side terminal. When the restoring force of the spring and the frictional force between the engaging units are balanced during movement of the electrodes, connection is released. The magnet is inserted inside the fixed-side terminal disposed outside the fixed-side electrode, and a position where the electrodes are separated (initial arc ignition position) is away from the fixed-side terminal and the magnet. The larger a distance from the magnet is, the smaller the intensity of the magnetic field generated by the magnet is, and thus the intensity of the magnetic field sufficient to magnetically drive an arc cannot be obtained during a period from when electrodes have just been separated to when the fixed-side electrode reaches a certain distance.

[0007] The present disclosure has been made to solve the above-described problem. An object of the present disclosure is to obtain an opening and closing device having high interruption performance and having a magnetic field intensity sufficient for arc extinction by a magnet when an arc has been generated, with a simple structure.

MEANS TO SOLVE THE PROBLEM

[0008] The present disclosure is directed to an opening and closing device for opening/closing between a first terminal and a second terminal arranged so as to face each other, the opening and closing device including a first electrode which is provided at the first terminal and a second electrode which is provided at the second terminal and driven so as to be separable from the first electrode, wherein the first electrode and the second electrode are brought into contact with each other and kept in a conduction state therebetween, by an attraction force between magnets provided inside the electrodes.

EFFECT OF THE INVENTION

[0009] According to the present disclosure, conduction between the first electrode and the second electrode is retained by the attraction force between the magnets inside the first electrode and the second electrode, and a magnetic field is formed around each electrode. Thus, the magnetic field necessary for arc extinction can be stably provided at the same time as when the arc is formed (the moment the electrodes are separated), so that interruption performance can be improved. In addition, a complicated engagement mechanism is not used,

and thus the structure can be simplified, and the processing cost and the number of assembly steps can be reduced.

BRIEF DESCRIPTION OF THE DRAWINGS

[0010]

[FIG. 1] FIG. 1 is a sectional view showing an opened state of an opening and closing device according to embodiment 1.

[FIG. 2] FIG. 2 is a sectional view showing a closed state of the opening and closing device according to embodiment 1.

[FIG. 3] FIG. 3 is a sectional view showing an opening operation of the opening and closing device according to embodiment 1.

[FIG. 4] FIG. 4 is a sectional view showing an arc-generated state when the opening and closing device according to embodiment 1 is opened.

[FIG. 5] FIG. 5 is a sectional view showing an opened state of an opening and closing device according to embodiment 2.

[FIG. 6] FIG. 6 is a sectional view showing an opening operation of the opening and closing device according to embodiment 2.

[FIG. 7] FIG. 7 is a sectional view showing an opened state of an opening and closing device according to embodiment 3.

[FIG. 8] FIG. 8 is a sectional view showing an opening operation of the opening and closing device according to embodiment 3.

[FIG. 9] FIG. 9 is a sectional view showing an opened state of an opening and closing device according to embodiment 4.

[FIG. 10] FIG. 10 is a sectional view showing an opening operation of the opening and closing device according to embodiment 4.

[FIG. 11] FIG. 11 is a sectional view showing an opened state of an opening and closing device according to embodiment 5.

[FIG. 12] FIG. 12 is a sectional view showing an arc-generated state when the opening and closing device according to embodiment 5 is opened.

[FIG. 13] FIG. 13 is a sectional view showing an opened state of an opening and closing device according to embodiment 6.

[FIG. 14] FIG. 14 is a sectional view showing an opening operation of the opening and closing device according to embodiment 6.

DESCRIPTION OF EMBODIMENTS

Embodiment 1

[0011] The configuration of embodiment 1 according to the present disclosure will be described with reference to FIG. 1. FIG. 1 is a sectional view showing an opened state

of an opening and closing device according to embodiment 1. Basic performance for opening a current path is configured by a first electrode 2a and a second electrode 3b facing each other. The first electrode 2a and the second electrode 3b are retained by guide members (not shown) or the like so as to move coaxially with a first terminal 1a and a second terminal 1b, respectively. In addition, the second electrode 3b is connected to a driving device (not shown), and can be driven and moved in the right-left direction of the sheet. The first electrode 2a and the second electrode 3b are coaxially-provided cylindrical columns, the outer circumferential edges of which are angled so as to be lowered backward. The first terminal 1a and the second terminal 1b are provided outside the first electrode 2a and the second electrode 3b, and are electrically connected through contacts 6a, 6b thereto, respectively. The first terminal 1a and the second terminal 1b are connected to other devices (not shown), and, when the first electrode 2a and the second electrode 3b come into contact with each other, a current conduction path is formed and power is transmitted. Further, an effect of relaxing an electric field and protecting the electrodes from damage due to an arc is also provided.

[0012] In addition, magnets 5a, 5b are provided in hollows at center portions of the first electrode 2a and the second electrode 3b, and are retained by covers 4a, 4b mounted to magnet surfaces facing each other, respectively. Here, a combination of magnetic-pole directions of the magnets 5a, 5b causes an attraction force to act between the electrodes when the first electrode 2a and the second electrode 3b come into contact with each other. The material of the covers 4a, 4b is a non-magnetic metal material such as tungsten copper, or a resin material such as PTFE (polytetrafluoroethylene).

[0013] Further, a fixed stopper 7a is mounted to the first terminal 1a, and a moving stopper 8a and a spring 9 are mounted to the first electrode 2a. The spring 9 is provided between the fixed stopper 7a and the moving stopper 8a, and, when the first electrode 2a is moved in the right-left direction of the sheet, the moving stopper 8a is also moved in the right-left direction of the sheet, whereby the spring 9 is expanded and contracted. At this time, the fixed stopper 7a is not moved, that is, the position thereof is not changed. As described above, the first electrode 2a is fastened to the first terminal 1a by the spring 9.

[0014] Next, operation in embodiment 1 will be described with reference to FIG. 1 to FIG. 4. FIG. 1 shows an opened state of the opening and closing device according to embodiment 1. The second electrode 3b is connected to the driving device (not shown), and is driven in the right-left direction of the sheet of FIG. 1 to open/close the path between the electrodes.

[0015] FIG. 2 shows a closed state of the opening and closing device according to embodiment 1, and is a sectional view when the second electrode 3b is closed. When the second electrode 3b comes into contact with the first electrode 2a, a current path is formed. At this

time, power flowing into the first terminal 1a connected to another device (not shown) is transmitted to the first electrode 2a through the contact 6a, and, through the second electrode 3b in contact with the first electrode 2a, flows into the contact 6b and the second terminal 1b, so that the power can be transmitted to another device.

[0016] In addition, the first electrode 2a and the second electrode 3b are engaged and connected by the magnetic attraction force between the magnets 5a, 5b provided in the hollows at the center portions thereof, and contact between the electrodes is maintained and conduction therebetween is retained even if the second electrode 3b is moved in the right direction of the sheet by the driving device (not shown).

[0017] FIG. 3 shows an opening operation of the opening and closing device according to embodiment 1, and is a sectional view in which, after being engaged and connected by the magnetic attraction force, the second electrode 3b is moved to an opened position thereof. When the second electrode 3b is driven in the right direction of the sheet by the driving device (not shown) in a state in which engagement by the magnetic attraction force is maintained and the contact between the first electrode 2a and the second electrode 3b is retained, the first electrode 2a is moved in the right direction of the sheet together with the second electrode 3b. At this time, the moving stopper 8a mounted to the first electrode 2a is also moved in the right direction of the sheet, whereby the spring 9 stores force. The fixed stopper 7a is mounted to the first terminal 1a and thus is not moved, that is, the position thereof is not changed. The more the second electrode 3b is driven in the right direction of the sheet, the more the restoring force of the spring 9 is increased. When the restoring force of the spring 9 and the attraction force between the magnets 5a, 5b are balanced, engagement by magnetism is released, and the first electrode 2a and the second electrode 3b are separated by the restoring force of the spring 9.

[0018] As described above, in order to open the opening and closing device, the attraction force between the magnet 5a of the first electrode 2a and the magnet 5b of the second electrode 3b driven to an opening-path direction while conduction therebetween is retained, and the restoring force of the spring 9 fastened to the first electrode 2a are used.

[0019] FIG. 4 is a sectional view in which an arc generated between the electrodes after release of engagement by magnetism is being interrupted, when the opening and closing device according to embodiment 1 is opened. When the restoring force of the spring 9 and the attraction force between the magnets 5a, 5b are balanced, engagement by magnetism is released and the first electrode 2a and the second electrode 3b are separated by the restoring force of the spring 9. Thereafter, an arc 10 is generated between the first electrode 2a and the second electrode 3b if current is being applied. The generated arc 10 is rotated in the circumferential direction of the electrodes by the magnetic field gener-

ated by the magnets 5a, 5b. As the rotation is continued, an arcing point (end portion of arc 10) at the surface of each electrode gradually moves toward an outer circumference of the electrode. The second electrode 3b is returned to the opened position thereof by the driving device (not shown), and the first electrode 2a is returned to an opened position thereof by the restoring force of the spring 9 after repeating minute vibration in the right-left direction of the sheet.

[0020] In the present disclosure, the first electrode 2a and the second electrode 3b are magnetically engaged and connected by the attraction force between the magnets 5a, 5b provided in the hollows at the center portions thereof. Thus, the structure is simple and an engaging unit having a complicated structure is unnecessary, so that processing cost and the number of assembly steps are reduced, sliding abrasion due to an increased number of operations does not occur, and an engagement mechanism can stably operate. Further, with the use of the magnets 5a, 5b as the engagement mechanism, the magnetic field necessary for extinction of the arc 10 can be stably provided at the same time as when the arc is formed (the moment the electrodes are separated), so that interruption performance is improved and electrode wear can be reduced.

[0021] In addition, the magnetic field generated by the magnets 5a, 5b causes the arc 10 to rotate in the circumferential direction of the electrodes to cool the arc 10, so that current interruption performance can be improved. When the arc 10 has been generated, current mainly has a component in a direction perpendicular to the surface of each electrode (axis direction). Arc current in the axis direction and the magnetic field in the radial direction generated by the magnets 5a, 5b cause Lorentz force to act in the circumferential direction, and thus the arc 10 rotates on the outer circumferences of the first electrode 2a and the second electrode 3b.

[0022] In the present disclosure, the magnets 5a, 5b are provided in the hollows at the center portions of the first electrode 2a and the second electrode 3b, and thus the magnets 5a, 5b are always located near an arcing point of the arc 10 (end portion of arc 10). Thus, the magnetic field necessary for extinction of the arc 10 can be stably provided at the same time as when the electrodes are separated. In addition, a magnetic member such as iron may be combined, whereby a force for retaining engagement by the magnetism of magnets can be adjusted.

[0023] As technology for improving current interruption performance, quick break is provided. The quick break is such a feature that, with a quick-acting mechanism provided at one of electrodes, an opening speed is increased to elongate an arc to a length needed for arc extinction within a time not causing contact damage, thus improving interruption performance. In the present disclosure, the magnetic field between the magnets 5a, 5b causes the arc 10 to rotate at the same time as when the electrodes are separated, and current interruption performance is

improved, so that opening at high speed is unnecessary and the necessary opening speed can be reduced. Therefore, a special quick-acting mechanism is unnecessary, and the load of the spring 9 can also be reduced, leading to reduction in size and weight as the entire device.

[0024] In addition, in a case where a magnetic material such as iron is used as a material for the covers 4a, 4b for retaining the magnets 5a, 5b, a magnetic field is strong at surfaces of the covers 4a, 4b, so that a foreign material which is a magnetic material generated by the arc 10 is easily attached, and engagement might become unstable. Therefore, if a non-magnetic metal material such as tungsten copper, or a resin material such as PTFE is used, a foreign material is inhibited from being attached and stable engagement can be provided. Further, when the resin material such as PTFE is used, the resin material comes into direct contact with the arc 10 and comes into contact with radiation light of the arc 10, whereby ablation gas generated from the resin material cools the arc 10 (ablation cooling), thereby improving current interruption performance. Further, the resin material such as PTFE has a low thermal conductivity, and thus an effect of transmitting heat of the arc 10 to the magnets 5a, 5b and inhibiting thermal demagnetization is also provided. In addition, the covers 4a, 4b may have a shape so as to cover not only end surfaces as shown in the drawing, but also the periphery thereof.

[0025] Further, the arc 10 is formed at the surfaces of the first electrode 2a and the second electrode 3b. If a mark (burn mark) of the arc 10 is left, or a foreign metal or the like is thereby attached, a force for retaining engagement by magnetism may vary. It has been known that an arcing point (end portion of arc 10) at the surface of each of the first electrode 2a and the second electrode 3b gradually moves toward an outer circumference of each electrode as the arc 10 is continuously rotated by the magnetic field of the magnets 5a, 5b. Thus, the outer circumferential edge of the first electrode 2a and the outer circumferential edge of the second electrode 3b are angled so as to be separated from each other toward the outer circumference of each electrode, and, even if a mark (burn mark) of the arc 10, a foreign metal, or the like is attached, the force for retaining engagement by magnetism does not vary.

Embodiment 2

[0026] FIG. 5 is a sectional view showing an opened state of an opening and closing device according to embodiment 2. Basic performance for opening a current path is configured by a first electrode 2c and a second electrode 3d facing each other. The first electrode 2c and the second electrode 3d are retained by guide members (not shown) or the like so as to move coaxially with the first terminal 1a and the second terminal 1b, respectively. In addition, the second electrode 3d is connected to a driving device (not shown), and can be moved in the right-

left direction of the sheet. The second electrode 3d is a coaxially-provided cylindrical column, the outer circumferential edge of which may be angled so as to be lowered backward. The first electrode 2c is also a coaxially-provided cylindrical column, and has a recessed hollow portion at a center of an end portion such that a protruding end portion of the second electrode 3d is fitted into the hollow portion. The hollow portion has a taper structure with an inner diameter decreasing toward the bottom on the deep side. The first terminal 1a and the second terminal 1b are provided outside the first electrode 2c and the second electrode 3d, and are electrically connected through the contacts 6c, 6d thereto, respectively. The first terminal 1a and the second terminal 1b are connected to other devices (not shown), and, when the first electrode 2e and the second electrode 3d come into contact with each other, a current conduction path is formed and power is transmitted. Further, an effect of relaxing an electric field and protecting the electrodes from damage due to the arc 10 is also provided.

[0027] In addition, a magnet 5d is provided in a hollow at a center portion of the second electrode 3d, and is retained by mounting a cover 4d thereto. In addition, a magnet 5c is provided inside a thickness part of the first electrode 2e where the hollow portion is present, and is retained by mounting a cover 4c thereto. Here, a combination of magnetic-pole directions of the magnets 5c, 5d causes an attraction force to act between the electrodes when the first electrode 2c and the second electrode 3d come into contact with each other. The material of the covers 4c, 4d is a non-magnetic metal material such as tungsten copper, or a resin material such as PTFE.

[0028] Further, a fixed stopper 7c is mounted to the first terminal 1a, and a moving stopper 8a and a spring 9 are mounted to the first electrode 2c. The spring 9 is provided between the fixed stopper 7c and the moving stopper 8a, and, when the first electrode 2c is moved in the right-left direction of the sheet, the moving stopper 8a is also moved in the right-left direction of the sheet, whereby the spring 9 is expanded and contracted. At this time, the fixed stopper 7c is not moved, that is, the position thereof is not changed. As described above, the first electrode 2c is fastened to the first terminal 1a by the spring 9.

[0029] Although operation in embodiment 2 is basically the same as that in embodiment 1, a contact part between the first electrode 2c and the second electrode 3d, and operation of engagement by magnetism will be described in detail with reference to FIG. 6. FIG. 6 shows an opening operation of the opening and closing device according to embodiment 2, and is a sectional view in which, after being engaged and connected by the magnetic attraction force, the second electrode is moved to an opened position thereof. The second electrode 3d is connected to the driving device (not shown), and is driven in the right-left direction of the sheet of FIG. 6 to open/close the path between the electrodes. When the second electrode 3d comes into contact with the first electrode 2c, a current path is formed. At this time, the end of the second

electrode 3d is in contact with a deepest portion of the hollow portion of the first electrode 2c. In addition, engagement by magnetism is maintained by the attraction force between the magnets 5c, 5d, and contact between the electrodes is retained even if the second electrode 3d is moved by the driving device (not shown).

[0030] In addition to the effects of embodiment 1, the following effects are provided. A combination of directions of the magnets 5c, 5d causes an attraction force to act between the electrodes when the first electrode 2c and the second electrode 3d come into contact with each other, but, when the electrodes are slightly separated from each other after engagement is released, a force in a repulsion direction occurs. Thus, the first electrode 2c is accelerated in the left direction of the sheet immediately after the electrodes are separated, and the opening speed can be increased. In addition, the outer diameter of the second electrode 3d may be smaller and thus the mass thereof decreases, and the structure of the driving device for driving the second electrode 3d can be downsized.

Embodiment 3

[0031] FIG. 7 is a sectional view showing an opened state of an opening and closing device according to embodiment 3. Basic performance for opening a current path is configured by a first electrode 2e and a second electrode 3f facing each other. The first electrode 2e and the second electrode 3f are retained by guide members (not shown) or the like so as to move coaxially with the first terminal 1a and the second terminal 1b, respectively. In addition, the second electrode 3f is connected to a driving device (not shown), and can be moved in the right-left direction of the sheet. The first electrode 2e is a coaxially-provided cylindrical column, the outer circumferential edge of which may be angled so as to be lowered backward. The second electrode 3f is also a coaxially-provided cylindrical column, and has a recessed hollow portion at a center of an end portion such that a protruding end portion of the first electrode 2e is fitted into the hollow portion. The hollow portion has a taper structure with an inner diameter decreasing toward the bottom on the deep side. The first terminal 1a and the second terminal 1b are provided outside the first electrode 2e and the second electrode 3f, and are electrically connected through contacts 6e, 6f thereto. The first terminal 1a and the second terminal 1b are connected to other devices (not shown), and, when the first electrode 2e and the second electrode 3f come into contact with each other, a current conduction path is formed and power is transmitted. Further, an effect of relaxing an electric field and protecting the electrodes from damage due to the arc 10 is also provided.

[0032] In addition, a magnet 5e is provided in a hollow at a center portion of the first electrode 2e, and is retained by mounting a cover 4e thereto. In addition, a magnet 5f is provided inside a thickness part of the second electrode 3f where the hollow portion is present, and is retained by

mounting a cover 4f thereto. Here, a combination of magnetic-pole directions of the magnet 5e, 5f causes an attraction force to act between the electrodes when the first electrode 2e and the second electrode 3f come into contact with each other. The material of the covers 4e, 4f is a non-magnetic metal material such as tungsten copper, or a resin material such as PTFE.

[0033] Further, a fixed stopper 7e is mounted to the first terminal 1a, and a moving stopper 8a and a spring 9 are mounted to the first electrode 2e. The spring 9 is provided between the fixed stopper 7a and the moving stopper 8a, and, when the first electrode 2e is moved in the right-left direction of the sheet, the moving stopper 8a is also moved in the right-left direction of the sheet, whereby the spring 9 is expanded and contracted. At this time, the fixed stopper 7e is not moved, that is, the position thereof is not changed. As described above, the first electrode 2e is fastened to the first terminal 1a by the spring 9.

[0034] Although operation in embodiment 3 is basically the same as that in embodiment 1, a contact part between the first electrode 2e and the second electrode 3f, and operation of engagement by magnetism will be described in detail with reference to FIG. 8. FIG. 8 shows an opening operation of the opening and closing device according to embodiment 3, and is a sectional view in which, after being engaged and connected by the magnetic attraction force, the second electrode is moved to an opened position thereof. The second electrode 3f is connected to the driving device (not shown), and is driven in the right-left direction of the sheet of FIG. 8 to open/close the path between the electrodes. When the second electrode 3f comes into contact with the first electrode 2e, a current path is formed. At this time, the end of the first electrode 2e is in contact with a deepest portion of the hollow portion of the second electrode 3f. In addition, engagement by magnetism is maintained by the attraction force between the magnet 5e, 5f, and contact between the electrodes is retained even if the second electrode 3f is moved by the driving device (not shown).

[0035] In addition to effects of embodiments 1 and 2, the outer diameter of the first electrode 2e may be smaller and thus the mass thereof decreases, and the spring 9 for fastening the first electrode 2e can be downsized.

Embodiment 4

[0036] FIG. 9 is a sectional view showing an opened state of an opening and closing device according to embodiment 4. Basic performance for opening a current path is configured by a first electrode 2g and a second electrode 3h facing each other. The first electrode 2g and the second electrode 3h are retained by guide members (not shown) or the like so as to move coaxially with the first terminal 1a and the second terminal 1b, respectively. In addition, the second electrode 3h is connected to a driving device (not shown), and can be moved in the right-left direction of the sheet. The second electrode 3h is a coaxially-provided cylindrical column, the end portion of

which is formed in a hemispherical shape. The first electrode 2g is also a coaxially-provided cylindrical column, and has a recessed hemispherical concave at a center of an end portion such that the second electrode 3h having a protruding shape is fitted into the concave. An outer circumferential edge of the first electrode 2g is rounded such that an electric field is not concentrated. The recessed shape of the first electrode 2g and the protruding shape of the second electrode 3h may be reversed. The first terminal 1a and the second terminal 1b are provided outside the first electrode 2g and the second electrode 3h, and are electrically connected through the contacts 6a, 6b thereto, respectively. The first terminal 1a and the second terminal 1b are connected to other devices (not shown), and, when the first electrode 2g and the second electrode 3h come into contact with each other, a current conduction path is formed and power is transmitted. Further, an effect of relaxing an electric field and protecting the electrodes from damage due to the arc 10 is also provided.

[0037] In addition, the magnets 5a, 5b are provided in hollows at center portions of the first electrode 2g and the second electrode 3h, respectively. Here, a combination of magnetic-pole directions of the magnets 5a, 5b causes an attraction force to act between the electrodes when the first electrode 2g and the second electrode 3h come into contact with each other.

[0038] Further, a fixed stopper 7a is mounted to the first terminal 1a, and a moving stopper 8a and a spring 9 are mounted to the first electrode 2a. The spring 9 is provided between the fixed stopper 7a and the moving stopper 8a, and, when the first electrode 2a is moved in the right-left direction of the sheet, the moving stopper 8a is also moved in the right-left direction of the sheet, whereby the spring 9 is expanded and contracted. At this time, the fixed stopper 7a is not moved, that is, the position thereof is not changed. As described above, the first electrode 2a is fastened to the first terminal 1a by the spring 9.

[0039] Although operation in embodiment 4 is basically the same as that in embodiment 1, a contact part between the first electrode 2g and the second electrode 3h, and engagement by magnetism will be described in detail with reference to FIG. 10. FIG. 10 shows an opening operation of the opening and closing device according to embodiment 4, and is a sectional view in which, after being engaged and connected by the magnetic attraction force, the second electrode is moved to an opened position thereof. The second electrode 3h is connected to the driving device (not shown), and is driven in the right-left direction of the sheet of FIG. 10 to open/close the path between the electrodes. When the second electrode 3h comes into contact with the first electrode 2g, a current path is formed. At this time, a hemispherical convex surface of the second electrode 3h is in contact with a hemispherical concave surface of the first electrode 2g. In addition, engagement by magnetism is maintained by the attraction force between the magnets 5a, 5b, and contact between the electrodes is retained even if the

second electrode 3h is moved by the driving device (not shown).

[0040] An engagement mechanism using magnetism can provide strong engagement force as long as contact surfaces of the electrodes are properly fitted with each other. However, it is considered that, in a case where the electrode is deviated from the axis or is inclined, the distance between the magnets becomes larger and the attraction force (engagement force) decreases. In embodiment 4, in addition to effects of embodiment 1, the concave end of the first electrode 2g and the convex end of the second electrode 3h are each formed in a hemispherical shape and are engaged with each other, and thus, even if the first electrode 2g or the second electrode 3h is deviated from the axis or is inclined at the time of closing, the distance between the magnets 5a, 5b does not become larger and engagement can be stably retained.

20 Embodiment 5

[0041] FIG. 11 is a sectional view showing an opened state of an opening and closing device according to embodiment 5. Basic performance to open a current path is configured by a first electrode 2a and a second electrode 3b facing each other. The first electrode 2a and the second electrode 3b are retained by guide members (not shown) or the like so as to move coaxially with the first terminal 1a and the second terminal 1b, respectively. In addition, the second electrode 3b is connected to the driving device (not shown), and can be moved in the right-left direction of the sheet. The first electrode 2a and the second electrode 3b are coaxially-provided cylindrical columns, the outer circumferential edges of which may be angled so as to be lowered backward. The first terminal 1a and the second terminal 1b are provided outside the first electrode 2a and the second electrode 3b, and are electrically connected through the contacts 6a, 6b thereto. The first terminal 1a and the second terminal 1b are connected to other devices (not shown), and, when the first electrode 2a and the second electrode 3b come into contact with each other, a current conduction path is formed and power is transmitted. Further, an effect of relaxing an electric field and protecting the electrodes from damage due to the arc 10 is also provided.

[0042] In addition, the magnets 5a, 5b are provided in hollows at center portions of the first electrode 2a and the second electrode 3b, and are retained by mounting the covers 4a, 4b thereto, respectively. Here, a combination of magnetic-pole directions of the magnets 5a, 5b causes an attraction force to act between the electrodes when the first electrode 2a and the second electrode 3b come into contact with each other. The material of the covers 4a, 4b is a non-magnetic metal material such as tungsten copper, or a resin material such as PTFE.

[0043] Further, magnets 11a, 11b are respectively provided inside the first terminal 1a and the second terminal 1b, and increase the intensity of the magnetic field in the

radial direction between the electrodes. Here, the magnets 11a, 11b may be combined with magnetic members.

[0044] A fixed stopper 7a is mounted to the first terminal 1a, and a moving stopper 8a and a spring 9 are mounted to the first electrode 2a. The spring 9 is provided between the fixed stopper 7a and the moving stopper 8a, and, when the first electrode 2a is moved in the right-left direction of the sheet, the moving stopper 8a is also moved in the right-left direction of the sheet, whereby the spring 9 is expanded and contracted. At this time, the fixed stopper 7a is not moved, that is, the position thereof is not changed. As described above, the first electrode 2a is fastened to the first terminal 1a by the spring 9. Although the same structure as that in embodiment 1 is described in FIG. 11, the magnets 11a, 11b may be provided inside the first terminal 1a and the second terminal 1b in each structure in embodiments 2 to 4.

[0045] Although operation in embodiment 5 is basically the same as that in embodiment 1, operation of engagement by magnetism, and operation when an arc is extinguished will be described in detail with reference to FIG. 12. FIG. 12 shows an arc-generated state when the opening and closing device according to embodiment 5 is opened, and is a sectional view in which an arc generated between the electrodes after release of engagement by the magnetic attraction force is being interrupted.

[0046] As a stage prior to a state in FIG. 12, in an opening operation, engagement by magnetism is maintained by the attraction force between the magnets 5a, 5b provided in the hollows at the center portions of the first electrode 2a and the second electrode 3b, and contact between the electrodes is retained even if the second electrode 3b is moved by the driving device (not shown). The magnets 11a, 11b generate a magnetic field in a direction in which the attraction force is increased, and thus, when the second electrode 3b is driven in the right direction of the sheet by the driving device (not shown) in a state in which the contact between the first electrode 2a and the second electrode 3b is retained, the first electrode 2a is moved in the right direction of the sheet together with the second electrode 3b.

[0047] Thereafter, when the restoring force of the spring 9 and the attraction force between the magnets 5a, 5b are balanced, engagement by magnetism is released and the first electrode 2a and the second electrode 3b are separated by the restoring force of the spring 9. Then, the arc 10 is generated between the first electrode 2a and the second electrode 3b if current is being applied. The generated arc 10 is rotated in the circumferential direction of the electrodes by the magnetic fields generated by the magnets 5a, 5b and the magnets 11a, 11b. As the rotation is continued, an arcing point (end portion of arc 10) at the surface of each electrode gradually moves toward an outer circumference of the electrode.

[0048] In the present embodiment 5, in addition to effects of embodiment 1, the arc 10 is rotated in the circumferential direction of the electrodes by the mag-

netic field generated by the magnets 5a, 5b and the magnetic field generated by the magnets 11a, 11b, to cool the arc 10, whereby current interruption performance can be further improved. When an arc has been generated, current mainly has a component in a direction perpendicular to each electrode surface (axis direction). Due to the arc current in the axis direction and the magnetic fields in the radial direction generated by the magnets 5a, 5b and the magnets 11a, 11b, Lorentz force acts in the circumferential direction, and thus the arc 10 is rotated on the first electrode 2a and the second electrode 3b. In particular, the inserted magnets 11a, 11b increase the magnetic field in the radial direction generated between the electrodes, thereby further improving interruption performance. In addition, the magnets 11a, 11b may be combined with magnetic members.

[0049] In particular, as the distance between the electrodes becomes larger, a middle-side part of the arc 10 becomes farther from the magnets 5a, 5b, and thus, at the middle-side part, the intensity of the magnetic field is weak and the middle-side part is less subjected to rotational driving by magnetism. Thus, the inserted magnets 11a, 11b increase the intensity of the magnetic field, and thus, even if the distance between the electrodes becomes larger, the arc 10 can be rotated not only at the end portions of the arc 10 but also the middle-side part, thereby further improving current interruption performance.

30 Embodiment 6

[0050] FIG. 13 is a sectional view showing an opened state of an opening and closing device according to embodiment 6. Basic performance for opening a current path is configured by a first electrode 2a and a second electrode 3b facing each other. The first electrode 2a and the second electrode 3b are retained by guide members (not shown) or the like so as to move coaxially with the first terminal 1a and the second terminal 1b, respectively. In addition, the second electrode 3b is connected to a driving device (not shown), and can be moved in the right-left direction of the sheet. The first electrode 2a and the second electrode 3b are coaxially-provided cylindrical columns, the outer circumferential edges of which are angled so as to be lowered backward. The first terminal 1a and the second terminal 1b are provided outside the first electrode 2a and the second electrode 3b, and are electrically connected through the contacts 6a, 6b thereto, respectively. The first terminal 1a and the second terminal 1b are connected to other devices (not shown), and, when the first electrode 2a and the second electrode 3b come into contact with each other, a current conduction path is formed and power is transmitted. Further, an effect of relaxing an electric field and protecting the electrodes from damage due to the arc 10 is also provided.

[0051] In addition, the magnets 5a, 5b are provided in hollows at center portions of the first electrode 2a and the

second electrode 3b, and are retained by mounting the covers 4a, 4b thereto, respectively. Here, a combination of magnetic-pole directions of the magnets 5a, 5b causes an attraction force to act between the electrodes when the first electrode 2a and the second electrode 3b come into contact with each other. The material of the covers 4a, 4b is a non-magnetic metal material such as tungsten copper, or a resin material such as PTFE.

[0052] Further, a fixed stopper 7a and a limiting stopper 12 are mounted to the first terminal 1a, and a moving stopper 8c and a spring 9 are mounted to the first electrode 2a. The spring 9 is provided between the fixed stopper 7a and the moving stopper 8c, and, when the first electrode 2a is moved in the right-left direction of the sheet, the moving stopper 8c is also moved in the right-left direction of the sheet, whereby the spring 9 is expanded and contracted. At this time, the fixed stopper 7a and the limiting stopper 12 are fixed to the first terminal 1a, that is, the positions thereof are not changed. As described above, the first electrode 2a is fastened to the first terminal 1a by the spring 9. Although the same structure as that in embodiment 1 is described in FIG. 13, the limiting stopper 12 may be provided at the first terminal 1a in each structure in embodiments 2 to 5.

[0053] Although operation in embodiment 6 is basically the same as that in embodiment 1, operation of engagement by magnetism between the first electrode 2a and the second electrode 3b will be described in detail with reference to FIG. 14. FIG. 14 shows an opening operation of the opening and closing device according to embodiment 6, and is a sectional view in which, after being engaged and connected by the magnetic attraction force, the moving stopper 8c is in contact with the limiting stopper 12. Engagement by magnetism is maintained by the attraction force between the magnets 5a, 5b provided in the hollows at the center portions of the first electrode 2a and the second electrode 3b, and contact between the electrodes is retained even if the second electrode 3b is moved by the driving device (not shown). The spring is inserted between the moving stopper 8c mounted to the first electrode 2a and the fixed stopper 7a mounted to the first terminal 1a, and, when the moving stopper 8c is moved in the right direction of the sheet together with the first electrode 2a, the spring 9 stores a force.

[0054] In due course, the moving stopper 8c comes into contact with the limiting stopper 12 which is a stop portion, and the force storing by the spring 9 is forcibly limited at a position in the left direction of the sheet with respect to a position where the restoring force of the spring 9 and the attraction force between the magnets 5a, 5b are balanced in embodiment 1. At this time, a displacement amount of the spring 9 for storing a force is constant, and the restoring force is smaller than the attraction force between the magnets 5a, 5b. The moving stopper 8c provided at the first electrode 2a comes into contact with the limiting stopper 12 which is the stop portion provided at the first terminal 1a, whereby move-

ment of the first electrode 2a is stopped. On the other hand, the second electrode 3b is continuously moved in the right direction of the sheet by the driving device (not shown). The driving device (not shown) causes a force to act in a repulsion direction, in addition to the restoring force of the spring 9, between the first electrode 2a and the second electrode 3b, and engagement by magnetism is released when such forces and the attraction force between the magnets 5a, 5b are balanced.

[0055] After engagement is released, the first electrode 2a starts to be moved in the left direction of the sheet by the restoring force of the spring 9. In addition, after the first electrode 2a and the second electrode 3b are separated, the arc 10 is generated between the first electrode 2a and the second electrode 3b if current is being applied.

[0056] In addition to effects of embodiment 1, the following effects are provided. In embodiment 1, when the restoring force of the spring and the attraction force between the magnets 5a, 5b are balanced, engagement by magnetism is released. Meanwhile, in embodiment 6, the moving stopper 8c comes into contact with the limiting stopper 12 which is the stop portion, whereby the driving device (not shown) causes a force to act in a repulsion direction, in addition to the restoring force of the spring 9, and engagement by magnetism is released when such forces and the attraction force between the magnets 5a, 5b are balanced. Therefore, the displacement amount of the spring for storing a force can be reduced by providing the limiting stopper 12, so that the deterioration of the spring 9 is reduced and the life of the spring 9 can be extended. In addition, even if the restoring force is slightly changed due to an increased number of operations, deterioration of the spring 9, and the like, variations in the opening speed can be suppressed. Further, even in such a case where there are individual differences in the magnets 5a, 5b and the spring 9, or where the first electrode 2a or the second electrode 3b is deviated from the axis or is inclined at the time of closing, variations in a position where engagement between the first electrode 2a and the second electrode 3b is released can be suppressed.

[0057] Although the disclosure is described above in terms of various exemplary embodiments and implementations, it should be understood that the various features, aspects, and functionality described in one or more of the individual embodiments are not limited in their applicability to the particular embodiment with which they are described, but instead can be applied, alone or in various combinations to one or more of the embodiments of the disclosure. It is therefore understood that numerous modifications which have not been exemplified can be devised without departing from the scope of the present disclosure. For example, at least one of the constituent components may be modified, added, or eliminated. At least one of the constituent components mentioned in at least one of the preferred embodiments may be selected and combined with the constituent components men-

tioned in another preferred embodiment.

DESCRIPTION OF THE REFERENCE CHARACTERS

[0058]

1a first terminal
 1b second terminal
 2a, 2c, 2e, 2g first electrode
 3b, 3d, 3f, 3h second electrode
 4a, 4b, 4c, 4d, 4e, 4f cover
 5a, 5b, 5c, 5d, 5e, 5f magnet
 6a, 6b, 6c, 6d, 6e, 6f contact
 7a, 7c, 7e fixed stopper
 8a, 8c moving stopper
 9 spring
 10 arc
 11a, 11b magnet
 12 limiting stopper

Claims

1. An opening and closing device for opening/closing between a first terminal and a second terminal arranged so as to face each other, the opening and closing device comprising:

a first electrode which is provided at the first terminal; and
 a second electrode which is provided at the second terminal and driven so as to be separable from the first electrode, wherein the first electrode and the second electrode are brought into contact with each other and kept in a conduction state therebetween, by an attraction force between magnets provided inside the electrodes.

2. The opening and closing device according to claim 1, wherein

closing between the first terminal and the second terminal is performed by bringing the first electrode and the second electrode into contact with each other, and
 opening between the first terminal and the second terminal is performed by separating the first electrode and the second electrode from each other.

3. The opening and closing device according to claim 2, wherein the first electrode is fastened to the first terminal by a spring.

4. The opening and closing device according to claim 3, wherein

the opening is performed by using an attraction force of the magnets between the first electrode and the second electrode which is driven in an opening-path direction while the conduction state is retained, and a restoring force of the spring by which the first electrode is fastened.

5. The opening and closing device according to claim 4, wherein

the opening is performed when the restoring force of the spring becomes larger than the attraction force of the magnets through the driving.

6. The opening and closing device according to claim 4, wherein

the opening is performed when the first electrode is brought into contact with a stop portion provided between the first terminal and the first electrode through the driving.

7. The opening and closing device according to any one of claims 1 to 6, wherein

the magnets have magnetic poles arranged so as to rotate an arc generated between the first electrode and the second electrode.

8. The opening and closing device according to any one of claims 1 to 7, wherein

end portions of the first electrode and the second electrode are formed so as to be separated toward an outer circumference of each electrode.

9. The opening and closing device according to any one of claims 1 to 8, wherein

the end portions of the first electrode and the second electrode are formed in a recessed shape and a protruding shape so as to be engaged with each other.

10. The opening and closing device according to claim 9, wherein

of the electrodes having the recessed shape and the protruding shape, one electrode having the recessed shape is formed so as to have an inner diameter decreasing toward a bottom thereof, and comes into contact, at the bottom, with another electrode having the protruding shape, to establish conduction therewith.

11. The opening and closing device according to any one of claims 1 to 10, wherein

a magnet is provided to at least one of the first terminal and the second terminal.

12. The opening and closing device according to any one of claims 1 to 11, wherein

at least one of the magnets is provided in combination with a magnetic member.

13. The opening and closing device according to any one of claims 1 to 12, wherein

covers are provided at surfaces, of the magnets, facing each other, and
a material of the covers is a non-magnetic metal material or a resin material.

5

14. The opening and closing device according to claim 13, wherein

10

the material of the covers is the resin material, and
ablation gas is generated by an arc generated between the first electrode and the second electrode.

15

20

25

30

35

40

45

50

55

FIG.3

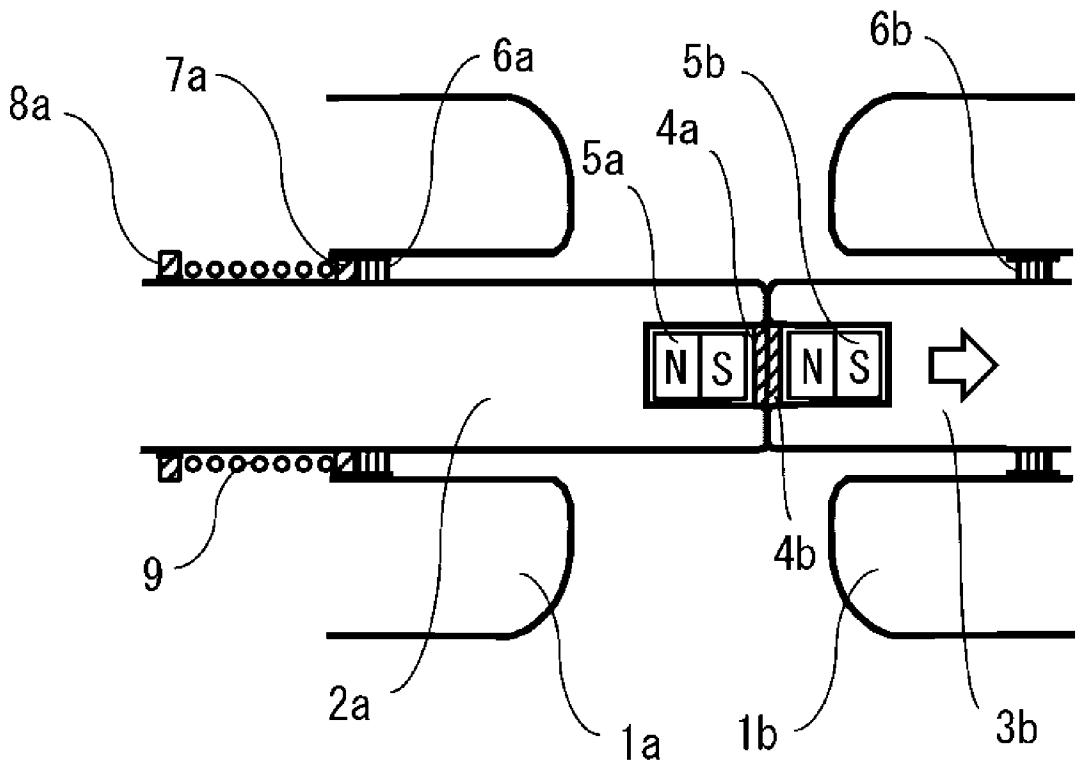

FIG.4

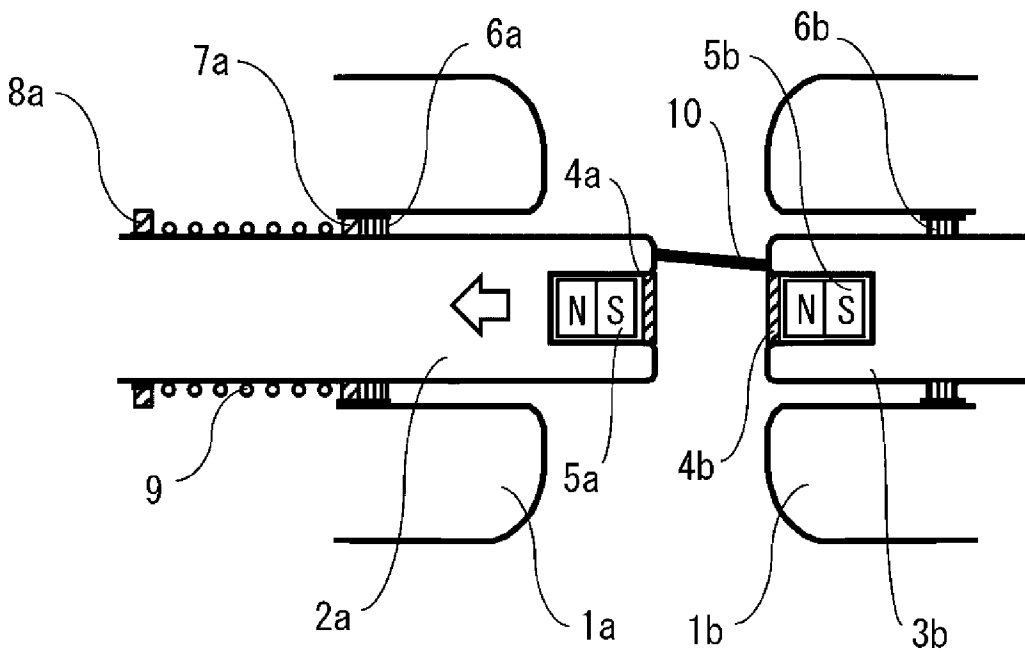

FIG.5

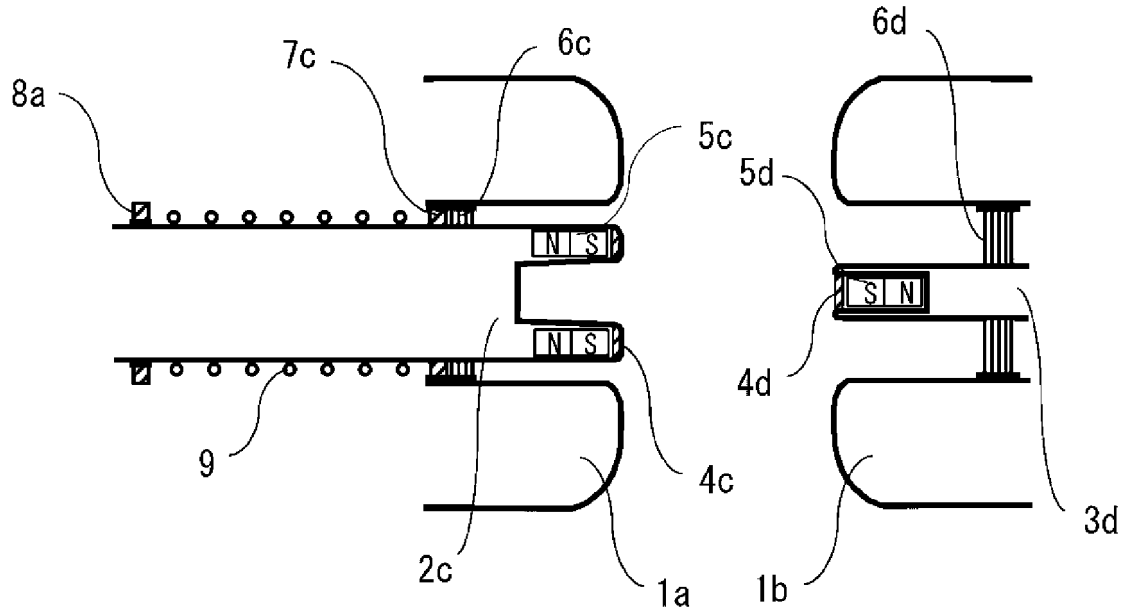

FIG.6

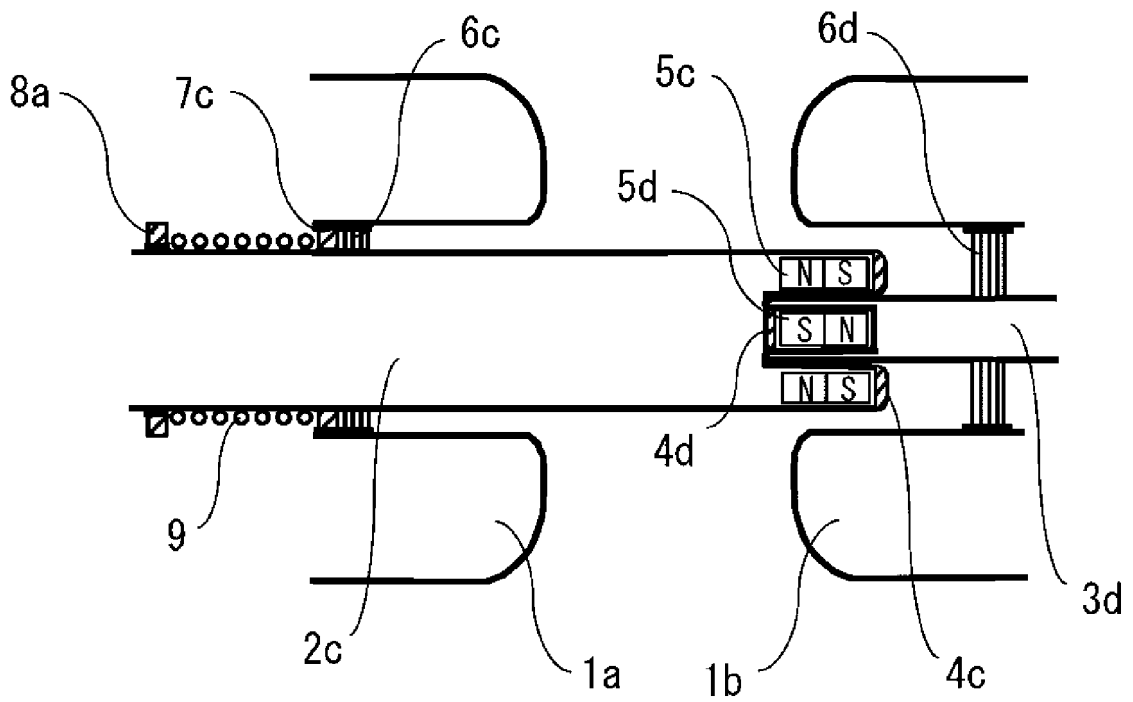

FIG.7

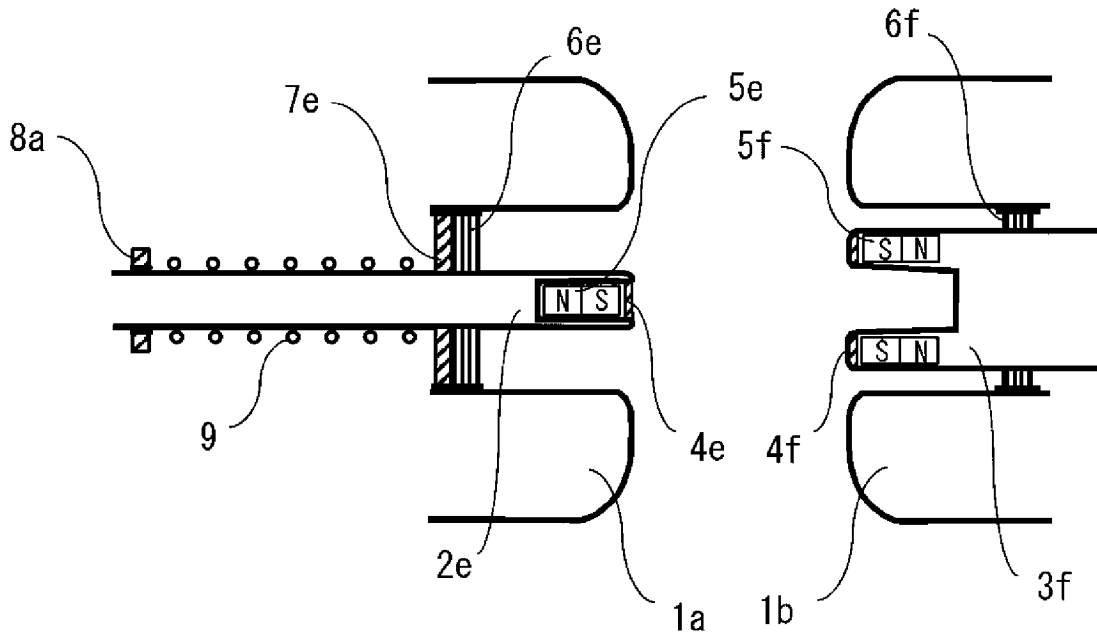

FIG.8

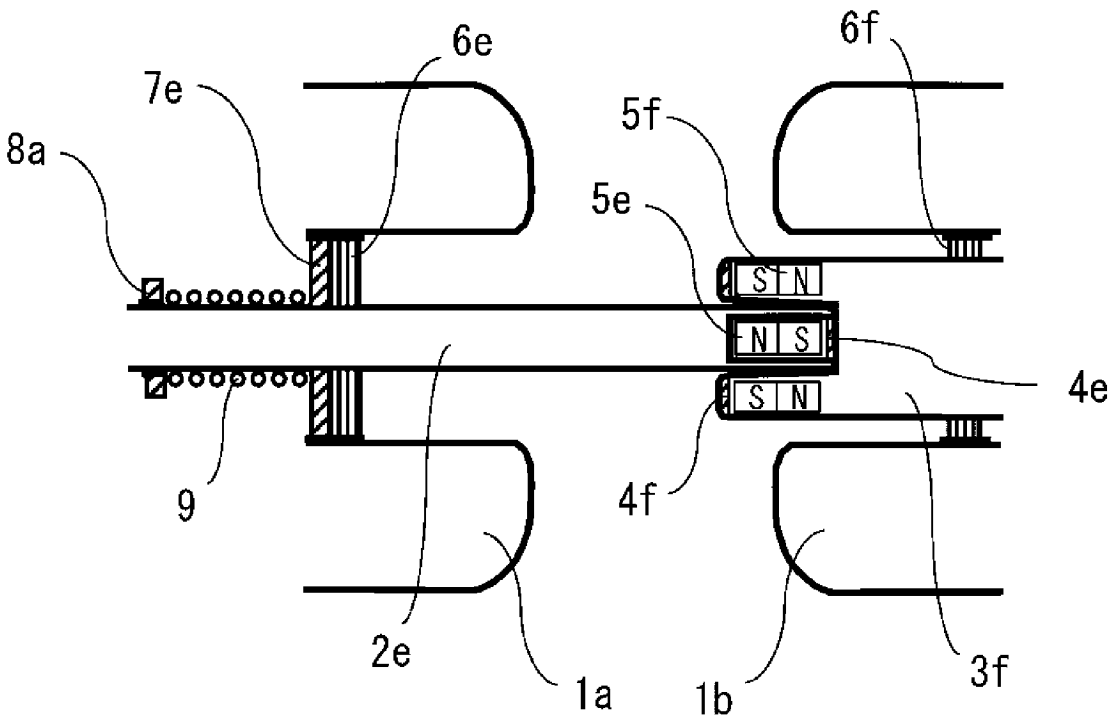

FIG.9

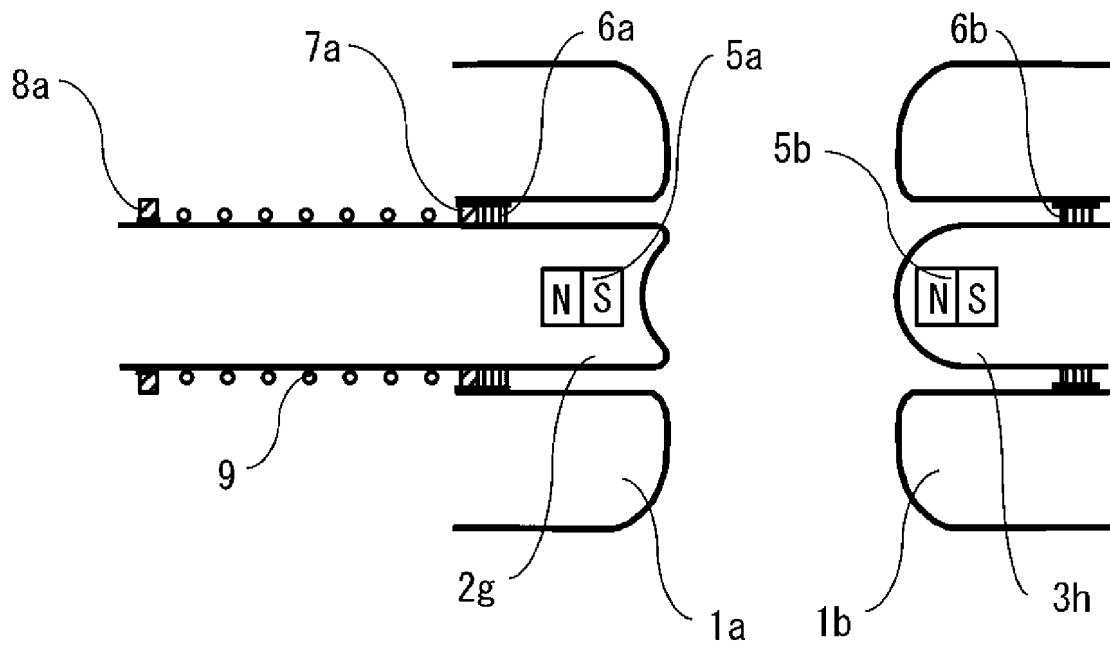

FIG.10

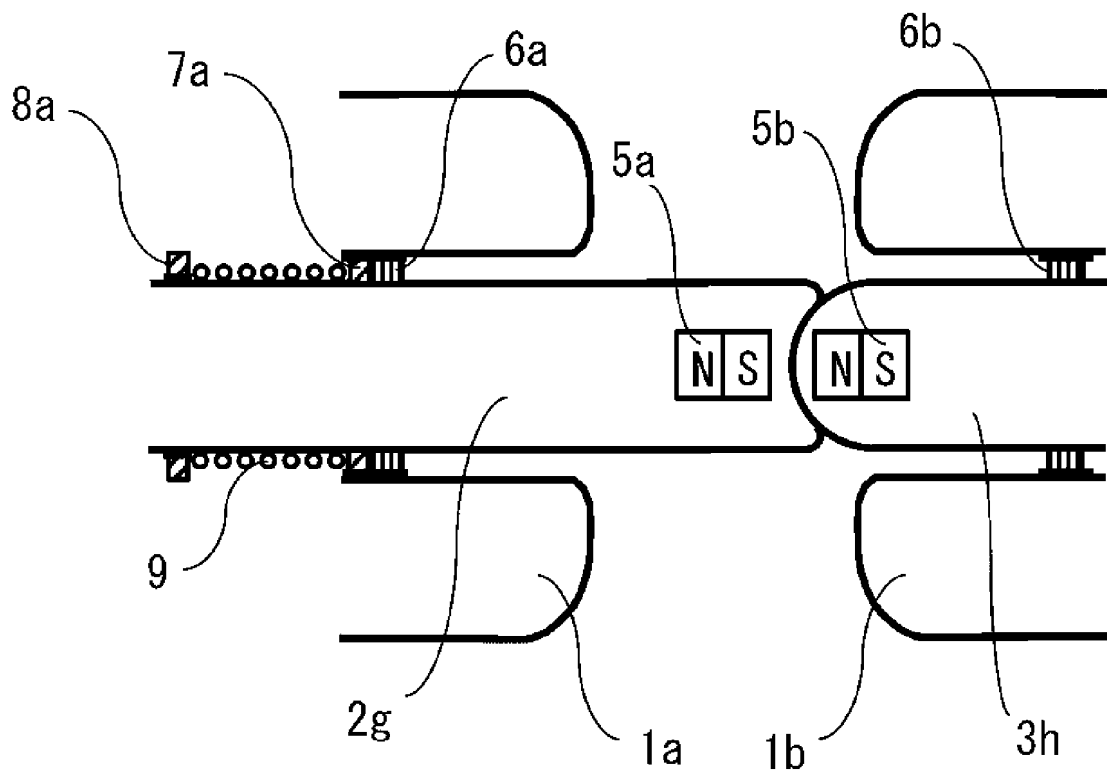

FIG.13

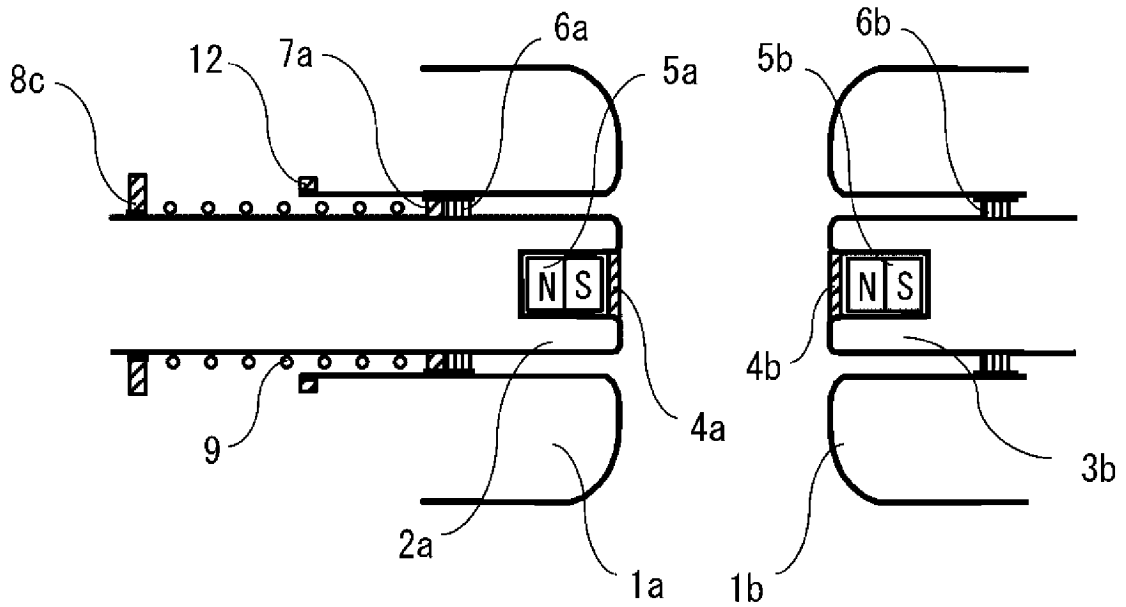
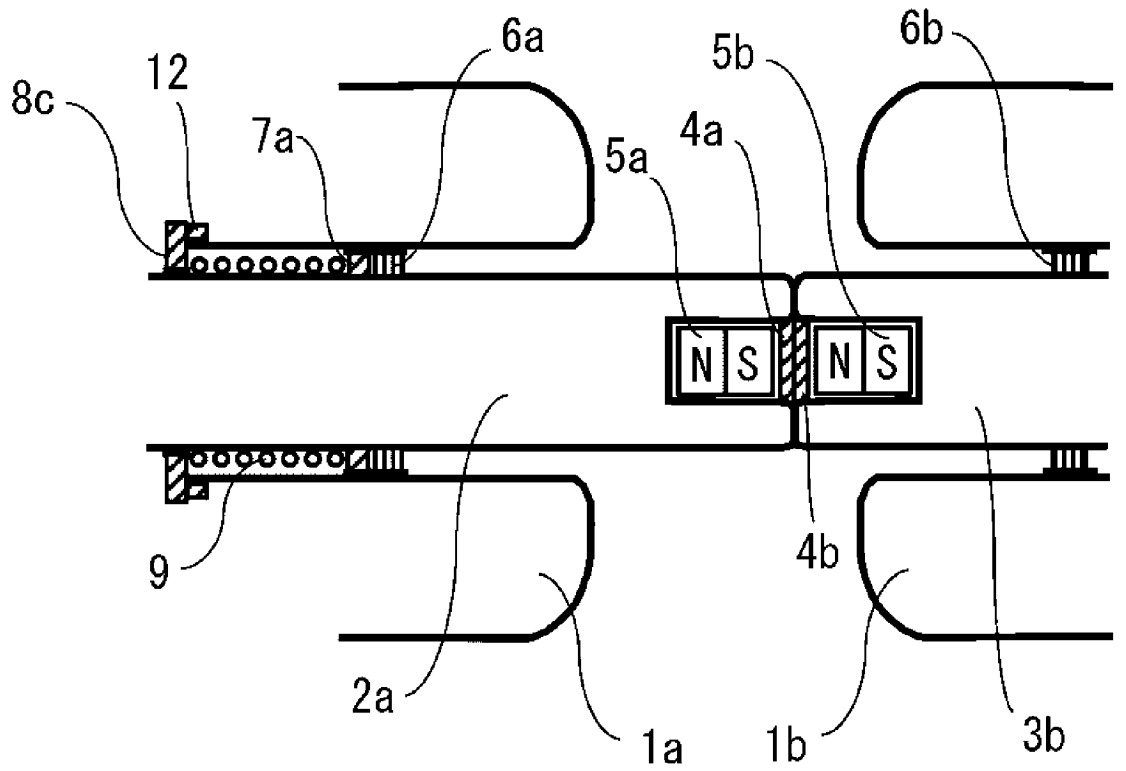

FIG.14



INTERNATIONAL SEARCH REPORT

International application No.

PCT/JP2022/016571

5	A. CLASSIFICATION OF SUBJECT MATTER	
	H01H 9/44 (2006.01)i; H01H 33/18 (2006.01)i FI: H01H33/18 Z; H01H9/44 A	
	According to International Patent Classification (IPC) or to both national classification and IPC	
10	B. FIELDS SEARCHED	
	Minimum documentation searched (classification system followed by classification symbols) H01H9/44; H01H33/18	
15	Documentation searched other than minimum documentation to the extent that such documents are included in the fields searched	
	Published examined utility model applications of Japan 1922-1996 Published unexamined utility model applications of Japan 1971-2022 Registered utility model specifications of Japan 1996-2022 Published registered utility model applications of Japan 1994-2022	
20	Electronic data base consulted during the international search (name of data base and, where practicable, search terms used)	
	C. DOCUMENTS CONSIDERED TO BE RELEVANT	
	Category*	Citation of document, with indication, where appropriate, of the relevant passages
25	X	Microfilm of the specification and drawings annexed to the request of Japanese Utility Model Application No. 84863/1981 (Laid-open No. 197144/1982) (YASKAWA ELECTRIC CORP.) 14 December 1982 (1982-12-14), specification, p. 5, lines 10-16, fig. 4
	Y	
	Y	WO 2021/152646 A1 (MITSUBISHI ELECTRIC CORP.) 05 August 2021 (2021-08-05) paragraphs [0024]-[0027], fig. 11
30	Y	JP 2010-251056 A (MITSUBISHI ELECTRIC CORP.) 04 November 2010 (2010-11-04) paragraph [0030], fig. 6
	A	JP 2003-346611 A (MITSUBISHI ELECTRIC CORP.) 05 December 2003 (2003-12-05)
	A	WO 2014/174917 A1 (HITACHI, LTD.) 30 October 2014 (2014-10-30)
35	A	JP 2020-42985 A (NISSIN ELECTRIC CO., LTD.) 19 March 2020 (2020-03-19)
	A	JP 2020-161459 A (HITACHI, LTD.) 01 October 2020 (2020-10-01) claim 3
40	<input checked="" type="checkbox"/> Further documents are listed in the continuation of Box C. <input checked="" type="checkbox"/> See patent family annex.	
45	* Special categories of cited documents:	"T" later document published after the international filing date or priority date and not in conflict with the application but cited to understand the principle or theory underlying the invention "A" document defining the general state of the art which is not considered to be of particular relevance "E" earlier application or patent but published on or after the international filing date "L" document which may throw doubts on priority claim(s) or which is cited to establish the publication date of another citation or other special reason (as specified) "O" document referring to an oral disclosure, use, exhibition or other means "P" document published prior to the international filing date but later than the priority date claimed "X" document of particular relevance; the claimed invention cannot be considered novel or cannot be considered to involve an inventive step when the document is taken alone "Y" document of particular relevance; the claimed invention cannot be considered to involve an inventive step when the document is combined with one or more other such documents, such combination being obvious to a person skilled in the art "&" document member of the same patent family
50	Date of the actual completion of the international search	Date of mailing of the international search report
	27 May 2022	07 June 2022
55	Name and mailing address of the ISA/JP	Authorized officer
	Japan Patent Office (ISA/JP) 3-4-3 Kasumigaseki, Chiyoda-ku, Tokyo 100-8915 Japan	
		Telephone No.

Form PCT/ISA/210 (second sheet) (January 2015)

INTERNATIONAL SEARCH REPORT

International application No.
PCT/JP2022/016571

5

C. DOCUMENTS CONSIDERED TO BE RELEVANT

Category*	Citation of document, with indication, where appropriate, of the relevant passages	Relevant to claim No.
A	WO 1994/014177 A1 (NU-LEC PTY. LTD.) 23 June 1994 (1994-06-23)	1-14

10

15

20

25

30

35

40

45

50

55

INTERNATIONAL SEARCH REPORT
Information on patent family members

International application No. PCT/JP2022/016571

5
10
15
20
25
30
35
40
45
50
55

Patent document cited in search report	Publication date (day/month/year)	Patent family member(s)	Publication date (day/month/year)
JP 57-197144 U1	14 December 1982	(Family: none)	
WO 2021/152646 A1	05 August 2021	(Family: none)	
JP 2010-251056 A	04 November 2010	(Family: none)	
JP 2003-346611 A	05 December 2003	(Family: none)	
WO 2014/174917 A1	30 October 2014	US 2016/0049268 A1 CN 105122411 A	
JP 2020-42985 A	19 March 2020	(Family: none)	
JP 2020-161459 A	01 October 2020	(Family: none)	
WO 1994/014177 A1	23 June 1994	CN 1097898 A	

REFERENCES CITED IN THE DESCRIPTION

This list of references cited by the applicant is for the reader's convenience only. It does not form part of the European patent document. Even though great care has been taken in compiling the references, errors or omissions cannot be excluded and the EPO disclaims all liability in this regard.

Patent documents cited in the description

- JP 2010027479 A [0004]