

R. G. POLSTER & A. LOEW.

COMBINED RAIL FASTENING AND TIE PLATE.

APPLICATION FILED MAR. 10, 1903.

NO MODEL.

2 SHEETS—SHEET 1.

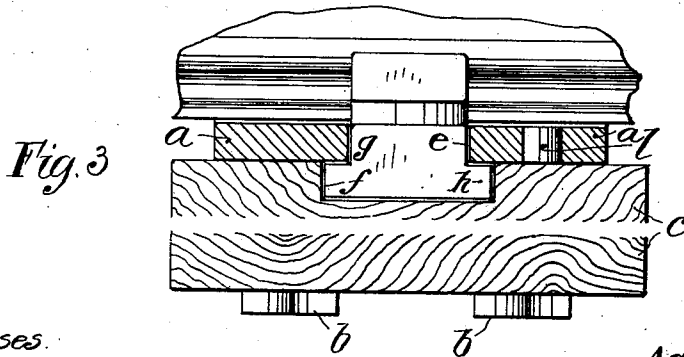
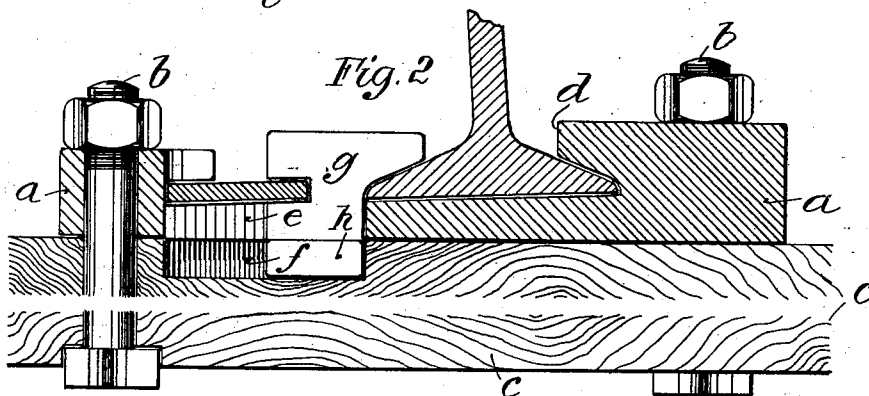
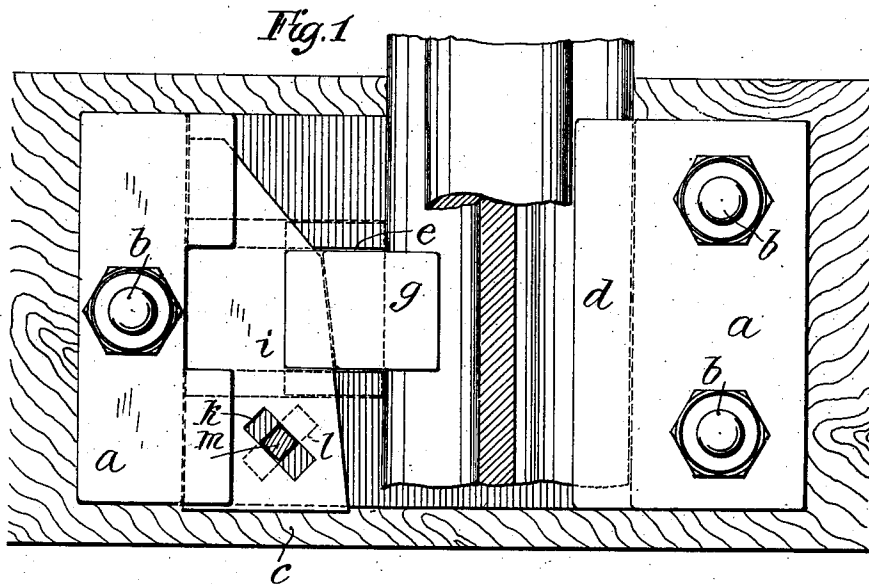

Witnesses:
 Hans Brenner
 Willi Kasper

Inventors:
 Adam Loew and
 Rudolf Georg Blöcher
 per Georg Sachs
 Attorneys

R. G. POLSTER & A. LOEW.
COMBINED RAIL FASTENING AND TIE PLATE.

APPLICATION FILED MAR. 10, 1903.

NO MODEL.

2 SHEETS—SHEET 2.

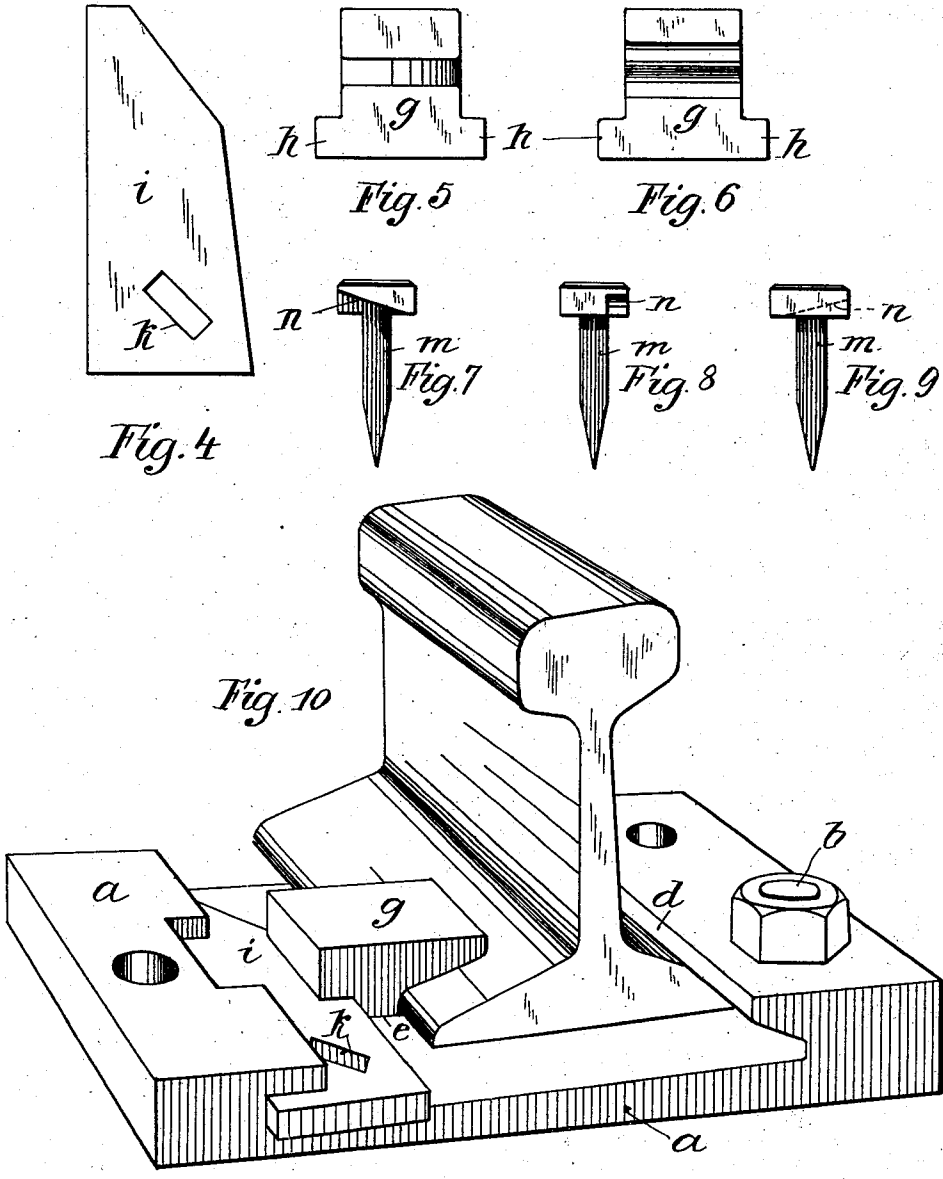

Witnesses
James Bremner
Willi Casper

Inventors.
Adam Loew and
Rudolf Georg Polster
per Gerson & Fackel
Attorneys

UNITED STATES PATENT OFFICE.

RUDOLF GEORG POLSTER AND ADAM LOEW, OF WORMS-PFIFFLIGHEIM,
GERMANY.

COMBINED RAIL-FASTENING AND TIE-PLATE.

SPECIFICATION forming part of Letters Patent No. 744,606, dated November 17, 1903.

Application filed March 10, 1903. Serial No. 147,157. (No model.)

To all whom it may concern:

Be it known that we, RUDOLF GEORG POLSTER, manufacturer, and ADAM LOEW, engineer, subjects of the Emperor of Germany, residing at Worms-Pfifflichem, Prussia, Germany, have invented certain new and useful Improvements in a Combined Rail-Fastening and Tie-Plate, of which the following is a specification.

Our invention relates to a combined rail-fastening and tie-plate for railroads; and it particularly consists in the special means for securing the rail in position on the tie-plate, which means allow a quick locking and unlocking of the said rail. Furthermore, the considerable loss of little iron fittings is avoided, which loss forms an inconvenience of the plurality of rail-fastenings now in use.

Our invention is illustrated in the accompanying drawings, in which—

Figure 1 shows a plan view of our combined fastening and tie-plate with a rail secured in position, parts of which are cut away. Fig. 2 is a longitudinal section through the said arrangement; Fig. 3, a cross-section thereof. Figs. 4 to 9 illustrate details. Fig. 10 is a perspective view of the said arrangement.

In the construction of our invention we use a rectangular tie-plate *a*, which has the usual obliquely-depressed bed or seat for receiving the rail-foot. The one end of said plate is formed to a hook-shaped clamp *d*, grasping over the adjacent flange of the rail. On the other side thereof a longitudinal slot *e* is centrally cut out from the bed portion of the plate *a* vertically to the rail, and a movable clamp *g* is guided within said slot and held therein by means of two projecting flanges *h* on both sides of said movable clamp. (See Figs. 2, 3, 5, and 6.) Bolts *b* are provided in suitable bolt-holes for securing the plate *a* on the tie *c*, and a suitable recess or groove *f* is cut out from the upper surface of said tie for receiving therein the base portion of clamp *g* and allowing same to move freely within said groove *f* and slot *e*.

A flat wedge or key *i* is provided for securing the movable clamp *g* in position on the adjacent flange of the rail, and the rear side of the clamp *g* and the elevated or non-depressed portion of the tie-plate oppositely thereto are slotted for receiving said wedge

or key *i* when driven in. Other short slots, *k* and *l*, are cut through the end of said wedge and the portion of the tie-plate thereunder, which slots are crossed at right angles, and in any position of the inserted wedge they form a free square hole for allowing a short spike *m*, as illustrated in Figs. 1, 7, 8, and 9, to be driven therethrough into the tie *c*, thus securing the wedge in position. In order to facilitate the drawing out of said spike *m*, the under side of the head thereof is beveled on one side, as clearly illustrated in Figs. 7, 8, and 9.

From the foregoing description it will be clear that for laying the rails it is only required for the layers to carry with them a plurality of wedges and spikes, as the whole plate *a*, with bolts *b* and clamp *g*, may be already fastened to the tie before the same is brought on the track. By this manner the considerable loss of little iron fittings is avoided, and the rails may be laid within a comparatively short time.

Having now described our invention, we claim—

1. In a combined rail-fastening and tie-plate, the combination of a tie-plate, a depressed rail-bed portion therein, a rigid rail-clamp formed on the one end of said plate, a longitudinal slot within said plate, a movable rail-clamp guided therein, provided with a groove, for guiding a horizontally-movable wedge or key for securing said second clamp in its fastening position and means for securing said wedge or key when inserted, substantially as described.

2. In a combined rail-fastening and tie-plate, the combination of a tie-plate, a vertically-adjustable rigid rail-clamp at the one end thereof, a movable rail-clamp guided in a longitudinal slot, provided with a groove, a wedge guided therein for holding said latter clamp in its fastening position, two crossed slots in the wedge or key and the tie-plate, a spike driven through said slots for securing the wedge or key in position, substantially as described.

RUDOLF GEORG POLSTER:
ADAM LOEW.

Witnesses:
JACOB ADRIAN,
H. W. HARRIS.