

D. A. CLEVELAND.
Stove-Pipe Damper.

No. 130,979.

Patented Sep. 3, 1872.

Fig 1.

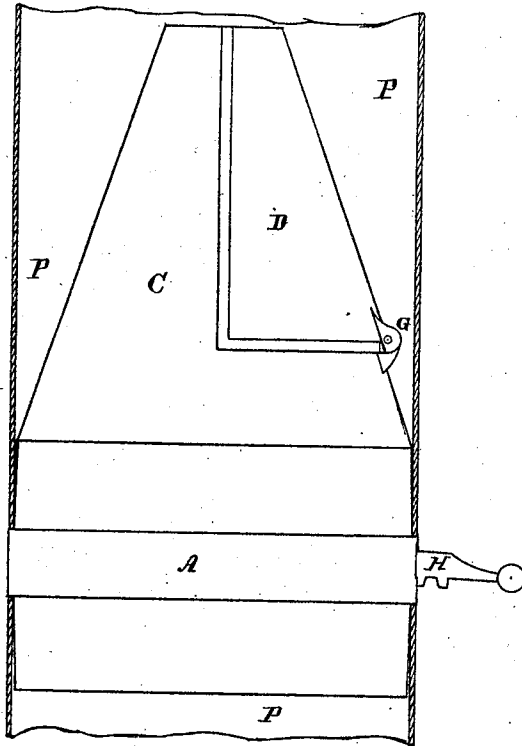
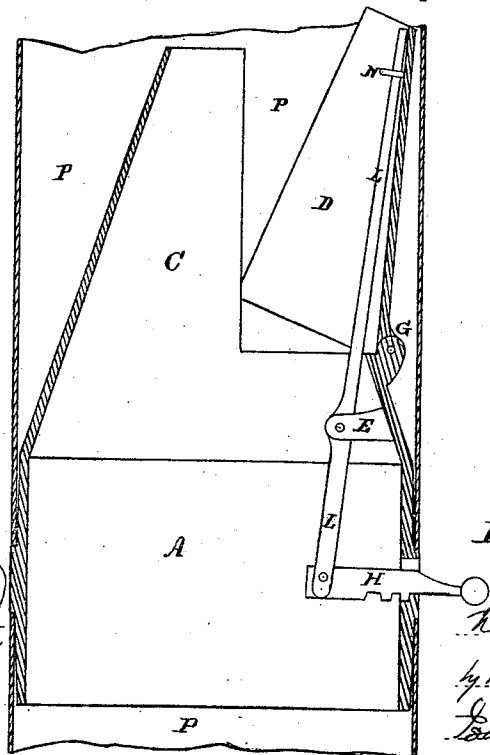

Fig 2.



Witnesses.

William Powell
David Keatman

Inventor.

David A. Cleveland
by his Atty,
Leanc A. Powell

UNITED STATES PATENT OFFICE.

DAVID A. CLEAVELAND, OF PROVIDENCE, RHODE ISLAND.

IMPROVEMENT IN STOVE-PIPE DAMPERS.

Specification forming part of Letters Patent No. **130,979**, dated September 3, 1872; antedated August 27, 1872.

SPECIFICATION.

I, DAVID A. CLEAVELAND, of the city and county of Providence and State of Rhode Island, have invented a new and Improved Damper for Smoke-Pipes, &c., of which the following is a specification, referring by letters to the accompanying drawing forming part of the same, in which—

Figure 1 is an elevation of my improved damper within the smoke-pipe, showing the damper closed. Fig. 2 is a vertical section of the same with the damper open.

Similar letters indicate like parts in both figures.

My invention relates to the combination, with a smoke-pipe or conductor, of a hollow cone or funnel with an adjustable section or door, in such a manner that the smoke-passage is contracted to the size of the open small end of the cone to diminish the natural draft, and by opening the movable section or door of the cone the smoke-passage is enlarged and the draft proportionately increased; the object being to provide a contracted central passage-way that will afford sufficient draft to maintain combustion without undue loss of heat, and means for enlarging and increasing the smoke-way and draft to hasten combustion.

In the drawing, C is the hollow cone or funnel, of cast-iron, arranged in the smoke-pipe P of a stove or furnace, and D is the adjust-

able section or door forming part of, and hinged at G to the outside of, the cone, and made to swing outward at the top, and afford increased passage-way for the smoke and draft by means of the lever L pivoted to the stand E, with its upper end connected by the staple N to the top of the door, and its lower end pivoted to a sliding stem, H, that extends through the side of the base of the cone, so as to open and close the door conveniently from the outside.

By means of the cone or funnel the passage-way in the pipe is contracted to a small round opening at the small end of the cone, which affords sufficient draft and escape for the smoke and unconsumed gases after the fire has become fully kindled, and it is desirable to restrict its consumption of the fuel; and when it is desirable to revive the fire, or newly kindle the same, by means of the movable section the cone is opened and additional smoke-passage and increased draft is obtained for the accomplishment of this result.

Having described my invention, I claim—

The combination of the fixed cone or funnel C, the movable section or door D, the lever L, stand E, and sliding stem H, substantially as described, for the purpose specified.

DAVID A. CLEAVELAND.

Witnesses:

ASAHEL S. HAWKINS,
ISAAC A. BROWNELL.