

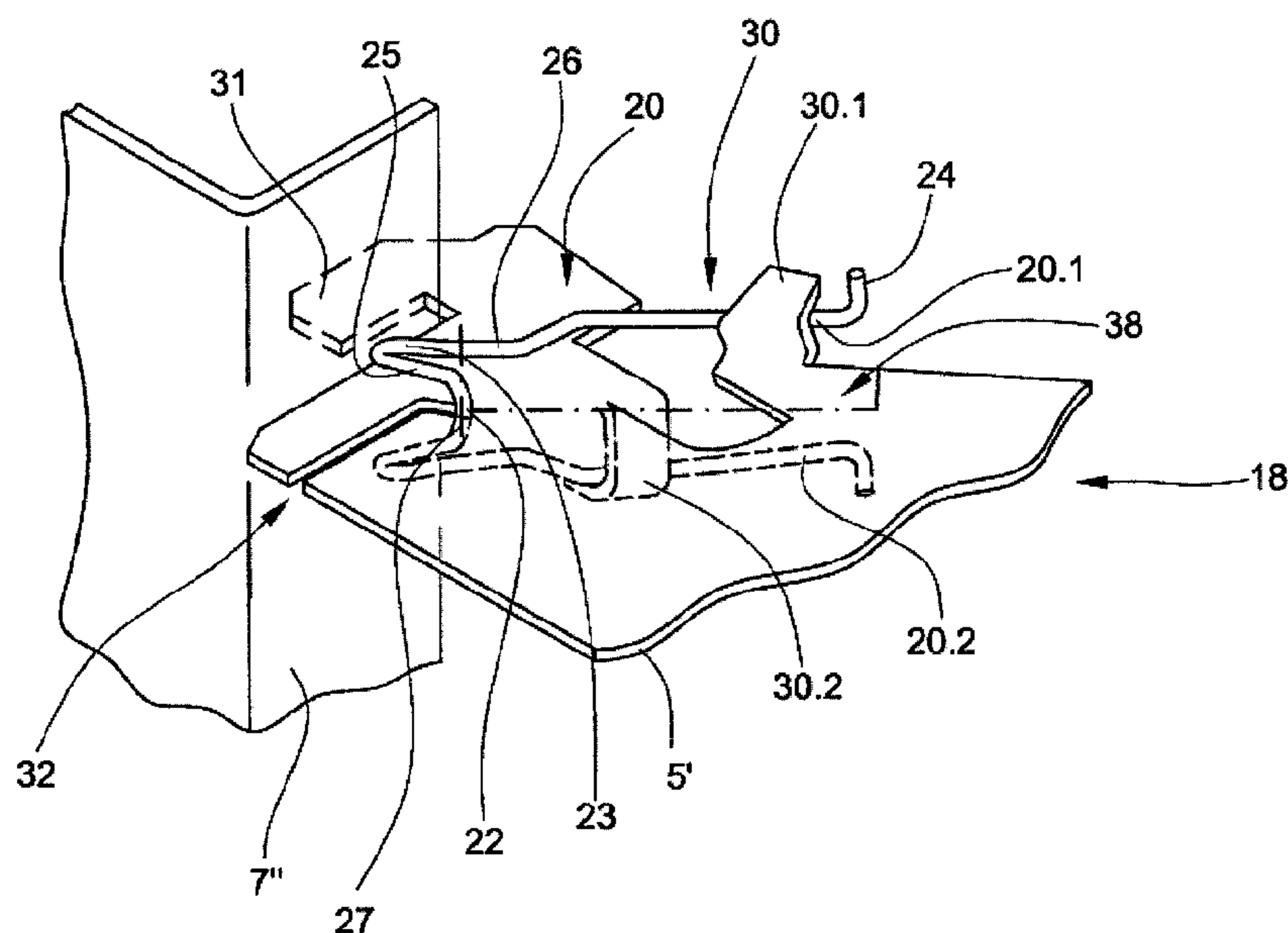

(86) Date de dépôt PCT/PCT Filing Date: 2012/07/09
 (87) Date publication PCT/PCT Publication Date: 2013/01/24
 (45) Date de délivrance/Issue Date: 2019/04/02
 (85) Entrée phase nationale/National Entry: 2014/01/21
 (86) N° demande PCT/PCT Application No.: EP 2012/063361
 (87) N° publication PCT/PCT Publication No.: 2013/010838
 (30) Priorité/Priority: 2011/07/21 (EP11174899.2)

(51) Cl.Int./Int.Cl. *B66B 23/00* (2006.01),
B66B 23/14 (2006.01), *B66B 7/02* (2006.01)
 (72) Inventeurs/Inventors:
MATHEISL, MICHAEL, AT;
SCHULZ, ROBERT, AT;
ILLEDITS, THOMAS, AT;
HAUER, UWE, DE
 (73) Propriétaire/Owner:
INVENTIO AG, CH
 (74) Agent: BORDEN LADNER GERVAIS LLP

(54) Titre : PIECE STRUCTURALE POURVUE D'UN DISPOSITIF DE FIXATION DESTINE A DES PIECES A MONTER
 (54) Title: COMPONENT HAVING A FASTENING APPARATUS FOR ADD-ON PARTS



(57) **Abrégé/Abstract:**

The invention relates to a component (5') of an escalator (1), of a moving walkway or of an elevator, which component (5') has a fastening apparatus (18) which comprises a spring element (20), a locking position (30) for locking the spring element (20) and a support position (31) for supporting an add-on part (7'') to be fastened. The spring element (20) is arranged pivotably on the component (5'), wherein, in a tensioned state, the spring element (20) is locked in the locking position (30), and the add-on part (7'') is pressed against the support position (31) by the tensioned spring element (20).

ABSTRACT

The invention relates to a component (5') of an escalator (1), of a moving walkway or of an elevator, which component (5') has a fastening apparatus (18) which comprises a spring element (20), a locking position (30) for locking the spring element (20) and a support position (31) for supporting an add-on part (7") to be fastened. The spring element (20) is arranged pivotably on the component (5'), wherein, in a tensioned state, the spring element (20) is locked in the locking position (30), and the add-on part (7") is pressed against the support position (31) by the tensioned spring element (20).

Component having a fastening apparatus for add-on parts**Description**

The invention relates generally to an escalator, a moving walkway or a lift. The invention relates particularly to a component which comprises a fastening device including a spring element, a detent point for detenting the spring element and a support point for support of an attachment to be fastened.

Lift installations comprise guide rails which are arranged in the lift shaft and which serve for guidance of a lift cage and a compensating weight movably arranged in the lift shaft. The guide rails are either arranged at a shaft frame or connected with the (concrete) shaft wall by means of a wall mount. The guide rails are usually firmly clamped to the wall mounts by means of clamping claws.

EP 1 679 280 describes an escalator comprising two supporting side walls or framework walls, which are connected together by means of transverse struts. Track rails are arranged at the side walls. These track rails serve for guidance of a step chain which is arranged between a first deflecting region and a second deflecting region. Correspondingly, the step belt of the escalator has a forward run and a return run, wherein two respective track rails are provided for each of the forward run and the return run. The track rails are fixedly connected with the side walls by means of a plurality of spring clips. The fastening of the track rails to the side walls or transverse struts by means of spring clips represents, by comparison with welding or screw-connecting of these components, a substantial simplification of assembly and has proved best in practice.

A disadvantage of the fastening device, which is disclosed in EP 1 679 280, with spring clips resides in the fact that the spring constant of the spring clips is relatively high so as to achieve a high clamping force and thereby a secure connection of the track rails with the side walls. These spring clips are therefore able to be mounted only with a substantial expenditure of force, for example by means of a hammer blow. The assistance of an assembly tool, for example a hammer, can, however, cause plastic deformations at the spring clip, which can lead to partial loss of the clamping force thereof. Moreover, the parts to be connected have to be produced

very precisely, since due to the high spring constant of the spring clip even small differences in the spring travel or deflection travel in the stressed state can lead to large differences in the clamping force present at the individual connecting points. In order to enable mounting of tracks and track rails by means of the known spring clips, these tracks and track rails are required in the form of hollow profile members with complicated design and expensive in production.

The object of the present invention is therefore to create a component with a fastening device which overcomes the disadvantages expressed in the foregoing. This object is fulfilled by a component of an escalator, a moving walkway or a lift, this component having a fastening device which includes a spring element, a detent point for detenting the spring element and a support point for support of an attachment to be fastened. In the described embodiments the spring element is pivotably arranged at the component, wherein in a stressed state the spring element is detented in the detent point and the attachment is pressed against the support point by the stressed spring element.

The fastening device described here enables problem-free mounting, but also rapid demounting of the attachments by hand without requiring use of a tool. This is a decisive advantage not only in production of an escalator or a moving walkway, but also in the installation thereof in a building and in the case of maintenance operations. Worn attachments such as tracks, track rails and guide rails can be exchanged by virtue of the fastening device within a short time, for example a few hours. Moreover, a high clamping force can be generated on the attachment even when the spring element has a substantially smaller spring constant than the spring clip known from the prior art. These advantages are made possible by the pivotable arrangement of the spring element at the component. In that case the pivot axis of the spring element acts as a lever bearing of the spring element and the spring element itself as a clamping lever.

In a first embodiment of the fastening device the spring element comprises a bearing point by which the spring element is pivotably arranged at the component. In addition, the spring element includes a clamping point and a lever end, wherein a short lever arm is arranged between the bearing point of the clamping point and a long lever arm between the clamping point and the lever end. When the spring element is stressed the attachment is arranged between the support point and the clamping point. Depending on the respectively selected translation ratio between the short lever arm and the long lever arm the spring element can detent in the detent point with a greater or lesser expenditure of force in the case of a

predetermined clamping force. Through the use of a spring element as a clamping lever the fastening device is particularly free of susceptibility to tolerance differences of the component, spring element and attachment. Even relatively large differences in the production dimensions of two fastening devices yield only small differences in the clamping force acting on the attachment.

In a second embodiment of the fastening device the spring element is constructed with mirror symmetry with respect to its longitudinal direction and has a bearing point by which the spring element is pivotably arranged at the component. Moreover, the spring element has, through the construction with mirror symmetry, two spring limbs, wherein each spring limb has a clamping point and a lever end. A respective short lever arm is arranged between the bearing point and each clamping point and a respective long lever arm is arranged between the clamping points and the lever ends. When the spring element is stressed, the component is arranged between the spring limbs and the attachment is arranged between the support point and the clamping points.

The second embodiment has all the advantages of the first embodiment. The second embodiment additionally has the further advantages that the spring element is trapped by the component in orthogonal direction with respect to the clamping force and therefore has no sensitivity to lateral forces which might act on the spring element. Correspondingly, this embodiment has an even higher degree of stability and security against unintended loosening than the first embodiment.

The spring element can be produced integrally from the component. This integral construction can, however, restrict design freedom, since the component is usually made from a constructional steel, for example S235JR+AR (tensile strength 360 N/mm^2 according to EN 10025-2:2004-10). This constructional steel has a lower tensile strength than spring steel, for example 38Si7, which has a tensile strength of $1300 - 1600 \text{ N/mm}^2$. Accordingly, the component and the spring element are preferably constructed as separate parts, wherein the component is made of constructional steel and the spring element of spring steel.

The clamping point of the spring element can be formed by an angled fold simple to produce. This has the advantage that the clamping point has a radiussing which is directed towards the attachment and, during clamping, permits a relative movement between the surface of the

attachment and the clamping point of the spring element. In addition, by virtue of the angled fold the point of force introduction of the clamping force at the attachment is given with sufficient precision.

In order to facilitate the mounting and clamping of the spring element, the long lever arm is at least twice as long as the short lever arm.

The fastening device can be used at many points within an escalator or moving walkway for connection of components. For example, the component can be a framework or support structure, which is formed from load-bearing side walls and transverse struts, of an escalator or moving walkway and the attachment can be a frame or a module of an escalator or a moving walkway. Usually designated as a frame is a flat component which protrudes from the supporting structure towards the inner side thereof and at which attachments such as track rails, guide rails and tracks can be arranged. In addition, they usually serve for stiffening of the supporting structure, particularly with respect to the torsional stiffness thereof.

Sections of the escalator or moving walkway are termed modules. These can be of different construction in correspondence with the function thereof. For example, a first module can have a deflecting region of the step chain, a second module can include the driving and deflecting region of the step chain and further, identical intermediate modules with side walls and transverse struts can be present. An intermediate module can also comprise a plurality of frames which are connected together by track rails, running rails and/or guide rails, wherein one or more intermediate modules can be inserted into an existing support structure. Through the joining together of two or more modules the two deflecting regions of the step chain can be connected together.

The frame or the module of an escalator or a moving walkway can now comprise even further fastening devices for further attachments. Thus, the frame or the module is the component and the attachment is a track rail, running rail or guide rail.

The fastening device can, however, also be used in lift construction. The component can, for example, be a wall mount arranged in a lift shaft or a shaft frame arranged in the lift shaft. A running rail of a lift cage and/or a compensating weight can, as attachments, be connected by means of the fastening devices with the wall mount or the shaft frame.

The detent point can be constructed in different ways. In a first embodiment the detent point can be formed at the component. In a further embodiment the detent point can comprise an insert part fastenable to the component. The insert part and the component are preferably designed in such a manner by projections, for example in the form of hooks, and recesses that the insert part is fixed by these and by means of the support force of the spring limb to the component. In addition, the clamping force of the spring element can be adapted to the conditions of use by means of differently designed insert parts.

In order to facilitate detenting of the spring element to be clamped a spreader wedge can be formed at the detent point. This can be constructed at the component, but also at the insert part.

The detent point can have specific characteristics which influence the operating behaviour of the escalator, moving walkway or lift. For example, the insert part can be made of plastics material so that vibrations can be damped and operating noises thereby reduced. The detent point can obviously also have differently constructed damping elements. Thus, plastics material inserts arranged in the region of contact between the spring element and the detent point are also conceivable.

Since the clamping force of the spring element acts only in one direction, the support point preferably has at least one abutment point for limitation of at least one movement direction of the attachment. The abutments not only limit one or more movement directions of the attachment relative to the component, but can also serve as assembly aids. For example, a running rail can be placed in the support points of the frames, wherein the abutment points prevent slipping of the running rail out of the support points.

The support point can additionally have a slide surface. This is particularly important for guide rails of a lift shaft. Buildings of concrete can over time exhibit substantial contraction, which leads to shortening of the lift shaft length. The distances between the wall mounts in the lift shaft correspondingly also change. The guide rails of steel do not have this contraction. If between the wall mounts and the guide rail no relative movement parallel to the length direction of the lift shaft were to be possible, the guide rails or the wall mounts would deform or even be destroyed. The same can also happen due to temperature fluctuations in the lift shaft, since concrete and steel have different coefficients of thermal expansion.

The slide surface can be a smooth surface of the support point, but a plastics material intermediate layer can also be arranged between the support point and the attachment. However, in the case of a plastics material intermediate layer the permissible surface pressure of the material is to be observed so that the clamping force of the spring element is not unacceptably reduced due to creep. In addition, compensation for dimensional differences due to construction can be provided by the plastics material intermediate layers, in which case a set of plastics material intermediate layers of different thickness is required. The plastics material intermediate layers can have the form of a slide shoe or a slide insert.

The support point can, however, also have slide-inhibiting means. These can be used particularly in the case of escalators and moving walkways, since there the environment of the track rails, running rails or guide rails is similarly usually of steel and a rigid connection of these attachments with the components such as frames, transverse struts and side parts is desired. As anti-slip means it is possible to construct, for example, tooth profiles or profiles with sharp points at the support point, the teeth of which penetrate into the contacting surface of the attachment as a consequence of the spring force of the spring element. In addition, rough surfaces such as, for example, abrasive coatings applied to the support point can also be used.

The fastening device is preferably so designed that the reaction force to the external forces acting on the attachment is oriented in the same direction as the clamping force of the spring element acting on the attachment. The external forces thereby do not oppose the clamping force and it is never possible to overcome the clamping force. Lifting of the attachment off the support point can thus be prevented.

The component of an escalator, a moving walkway or a lift with a fastening device is explained in more detail in the following on the basis of examples and with reference to the drawings, in which:

- Figure 1 shows, in schematic illustration, an escalator with track rails and with a step belt;
- Figure 2 shows a section through the escalator along the line A-A of Figure 1, with frames as bearers of the track rails;

- Figure 3 shows, in three-dimensional view, a construction of a fastening device which detachably connects a frame with a framework or support structure;
- Figure 4 shows, in three-dimensional view, a frame - which is illustrated in Figure 2 - with tracks, running rails and guide rails, wherein the tracks and running rails are fastened to the frame by fastening devices;
- Figure 5 shows, in plan view, the frame - which is illustrated in Figure 4 - with tracks, running rails and guide rails;
- Figure 6 shows, in plan view and to enlarged scale, the detail B - which is marked in Figure 5 - with a first design of the support points;
- Figure 7A shows, in sectional plan view, a second design possibility of the support point constructed at the component;
- Figure 7B shows, in sectional plan view, a third design possibility of the support point constructed at the component;
- Figure 8 shows the detent point, which is illustrated in Figures 4 to 6 and constructed at the component, in three-dimensional view; and
- Figure 9 shows a guide rail of a lift in three-dimensional view, which is arranged in a lift shaft (not illustrated).

Figure 1 and Figure 2 show an escalator 1 with a balustrade 2, which carries a handrail 2.1, and steps 4 laterally guided between base plates 3. The escalator 1 connects a first storey E1 with a second storey E2. Guide rollers 4.1 of the steps 4 travel on track rails 6.3", 6.4" or on tracks 6.1", 6.2", which are fastened at the frames 7 by the fastening devices 8. In addition, two guide rails 6.5 are also fixed to the frame 7 by a fastening device 8. These fastening devices 8 are described in more detail further below with reference to Figures 3 to 9. Each frame 7 is connected with a framework 5 of the escalator 1 by means of, for example, a screw connection, weld connection, press-fit connection, rivet connection or through-joining (clinching).

As shown in Figure 3 in three-dimensional illustration the frame as attachment 7" can also be connected with the framework as component 5' by means of a fastening device 18. Since the fastening device 18 is quickly releasable, this form of fastening of the frames as attachments 7" to the framework represents an inestimable advantage if the escalator or moving walkway due to age has to be equipped with new tracks and/or frames.

The fastening device 18 comprises a spring element 20 with two spring limbs 20.1, 20.2 and a bearing point 22. Each spring limb 20.1, 20.2 has a clamping point 23 and a lever end 24. A respective short lever arm 25 is arranged between the bearing point 22 and the clamping points 23 and a respective long lever arm 26 is arranged between the clamping points 23 and the lever ends 24. The spring element 20 is constructed to have mirror symmetry with respect to its longitudinal direction, wherein the mirror plane is arranged between the two spring limbs 20.1, 20.2 and orthogonally to the pivot axis 27 of the bearing point 22.

In addition, a detent point 30 constructed at the component 5', a support point 31 and a mounting receptacle 32 belong to the fastening device 18. The detent point 30 illustrated in Figure 3 comprises two yokes 30.1, 30.2 formed at the component 5', wherein each yoke 30.1, 30.2 receives a respective long lever arm 26 when the spring element 20 is stressed.

The fastening of the attachment 7" to the component 5' is extremely simple. Initially, the spring element 20 or the bearing point 22 thereof is inserted into the mounting receptacle 32 and, in particular, so that the component 5' is arranged between the two spring limbs 20.1, 20.2. However, the two long lever arms 26 may not yet detent in the detent point 30. The two spring limbs 20.1, 20.2 are to be brought into a starting position 38 so that the attachment 7" can be inserted into the support point 31. The attachment 7" is subsequently inserted into the support point 31 and aligned. The two spring limbs 20.1, 20.2 can now be pivoted, lifted over the yokes 30.1, 30.2 and detented under the yokes 30.1, 30.2. Through pivotation of the spring element 20 about the pivot axis 27 the clamping points 23 stand against the attachment 7" and press it against the support point 31 still before the spring limbs 20.1, 20.2 reach the detent point 30. Due to the lever translation of the short lever arm 25 and the long lever arm 26 a very high clamping force or biasing force acting on the attachment 7" can be generated notwithstanding manual assembly.

Figure 4 shows an individual frame of Figure 2 with attached running rails, tracks and guide rails in three-dimensional illustration. The frame is thus the component 7', the running rails are attachments 6.1", 6.2", the tracks are attachments 6.3", 6.4" and the guide rail is similarly an attachment 6.5". The fastening devices 8 correspond, apart from the differently designed detent point 41, with the fastening device 18 illustrated in Figure 3, for which reason the same reference numerals are used for identical features. The detent point 41 of the spring element 20 is illustrated in Figure 8 and explained in more detail further below.

In addition, two guide rails 9.1, 9.2 made of thin sheet metal are arranged at the component 7'. These limit possible lifting of the guide rollers or step rollers, which are not illustrated, off the attachments 6.1", 6.2". The U-shaped guide rails 9.1, 9.2 can by virtue of the small sheet metal thickness be splayed transversely to the length direction and can be detented, without a large expenditure of force, in dovetail feet 10, which are formed at the component 7'. The guide rail 9.1, 9.2 can obviously also be fixed to the component 7' by means of a fastening device 8.

Figure 5 shows in plan view the frame or component 7', which is illustrated in Figure 4, with the tracks, running rails and guide rails as attachments 6.1", 6.2", 6.3", 6.4", 6.5". In this view the fastening devices 8 with the clamped spring elements 20 can be seen substantially more easily. The effective lever lengths L_1 , L_2 are also illustrated at the example of an attachment 6.1 (running rail). Due to the angled fold 29 of the spring element 20 and the arrangement of the spring element 20 at the component 7' these are shorter than the associated lever arms 25, 26. The effective lever length L_2 of the long lever arm 26 is obviously dependent on the direction of the manual force F_H to be exerted for the detenting. The effective lever length L_1 of the short lever arm 25 changes only slightly when the angled fold 29 or the thereby-formed clamping point 23 has a position which differs, due to production tolerances, from the design position. By design position there is to be understood the theoretical position of the spring element 20 in the stressed state when all dimensions of the spring element 20, the component 7' and the attachment 6.1" are taken into consideration without departures from tolerances. Obviously the clamping point 23 should never exceed the dead centre, i.e. the effective lever length L_1 of the small lever 25 may never be smaller than 0. If the dead centre is exceeded and thus the effective lever length L_1 is smaller than 0, the spring element 20 cannot be stressed, since the clamping point 23 with increasing pivot angle of the spring element 20 in clockwise sense and relative to the component 7' moves away from the attachment 6.1". Correspondingly, the fastening device 8 has a very high security against failure. This is given by the fact that a non-

stressable spring element 20 is immediately recognised during assembly and measures for remedying this, for example insertion of a plate between the clamping point 23 and the attachment 6.1", can be undertaken immediately. Broken or deformed spring elements 20 are immediately recognised, during inspections and/or maintenance operations, by virtue of the absence of clamping force and can be replaced, wherein the number of fastening devices 8 over the length direction of an escalator, a moving walkway or a lift shaft is to be so selected that the functional reliability is guaranteed even in the case of failure of individual spring elements 20.

In addition, the advantageous positioning of the spring elements 20 with respect to external forces acting on the tracks and running rails can be illustrated by means of Figure 5. The external force F_S , the clamping force F_F of the spring element 20, the bending moment M_L caused by the external force F_S and the supporting of the moment M_L by the reaction force F_R are illustrated by way of the example of an attachment 6.2" (track). The external force F_S acts by virtue of the mass and the load, which is to be borne, of a step of the escalator or a plate of a moving walkway by way of the guide roller 4.1 on the attachment 6.2". This is supported by the component 7', wherein due to the design of the rail support 7.1 thereof a bending moment M_L is present in the component 7' and a small elastic deformation or a small tipping of the rail support 7.1 could arise due to the bending moment M_L . This tipping is counteracted not only by the rail support 7.1, but also, through the folding of the attachment 6.2", by the support point 31. This reaction force F_R acting on the support point 31 has the same direction as the clamping force F_F of the spring element 20. In addition, transverse forces F_Q which can similarly act via the guide rollers 4.1 on the attachment 6.2" are also supported by the support point 31.

Figure 6 shows in larger-scale illustration the detail B marked in Figure 5. This shows that two attachments 6.3", 6.4" can also be fastened to the component 7' by one fastening device 8. Obviously, three or even more attachments can also be fastened to the component 7' by the fastening device 8. In particular, the lack of sensitivity of the fastening device 8 with respect to large production tolerances has a bearing here.

In order that a relative movement in the direction of the length direction of the attachments 6.3", 6.4" between the component 7' and the contacting attachment 6.3" can be prevented, the support point 51 of the component 7' can have a suitable shaping, for example a toothed profile 43. This can have, for example, a higher level of hardness than the material of the attachment

6.3". When the spring element 20 is stressed, the protruding teeth of the toothed profile 43 partly penetrate into the material of the attachment 6.3". This mechanically positive couple prevents any relative movement between the component 7' and the attachment 6.3" in a plane extending orthogonally to the direction of the clamping force F_F of the spring element 20. Here, too, the lack of sensitivity of the fastening device 8 to different depths of penetration proves to be an important characteristic. The illustrated toothed profile 43 is only by way of example and obviously use can also be made of further suitable toothed profiles 43 or profiles with sharp points. Moreover, a slide-inhibiting coating, for example a flame-sprayed carbide hard-material coating or a slide-inhibiting or slip-resistant intermediate layer can also be arranged between the support point 51 and the attachment 6.3" in place of the toothed profile 43.

The abutment points 34, 35, which are arranged at the component 7' and which limit the movement directions of the attachments 6.3", 6.4" in at least one direction, are also readily recognisable.

Moreover, the design of the mounting receptacle 32, which is formed in the component 7', is also apparent. This is preferably formed not as a bore, but as a slot-shaped recess. The open end of the mounting receptacle 32 preferably extends in the opposite direction to the bearing force F_P of the spring element 20. This design enables simple insertion of the spring element into the component 7'.

Figure 7A shows a further design possibility of the support point 61, which is formed at the component 7', in sectional plan view. In this case a relative movement of attachment 6.1" in the direction of its length direction is desired. The attachment 6.1" is mentioned only by way of example and the other attachments (not illustrated) can also be fixed to the component 7' by means of a suitably designed fastening device. A relative movement can be permitted without problems, since the partly illustrated spring element 20 is held in stationary position at the component 7' by the bearing point and detent point (both not illustrated) penetrating the component 7'. In order to assist a possible relative movement, a slide shoe 52 is arranged between the attachment 6.1" and the support point 61. In the illustrated embodiment this is made from a synthetic material with high strength and low creep behaviour, for example from a glassfibre-reinforced synthetic material. The slide shoe 52 of synthetic material additionally has characteristic damping vibrations.

It is obviously possible, as illustrated in Figure 7B to arrange between the spring element 20 and the attachment 6.1" a slide insert 53 which improves the slide characteristics and/or vibration-damping characteristics between the attachment 6.1" and the clamping points 23 of the spring element 20. In addition, the clamping points 23 can be mutually supported in the direction of the slide movement X by the slide insert 53 in order to avoid lateral drift.

Figure 8 shows the detent point 41, which is formed at the component 7', in three-dimensional view. For reasons of clarity the mounting receptacle formed at the component 7' was not illustrated, for which reason the entire spring element 20 and the bearing point 22 thereof are visible. The detent point 41 comprises a hook 71, which is formed at the component 7', and an insert part 72 with a passage 72.1. In the assembled state the hook 71 extends through the passage 72.1. The insert part 72 is in addition secured in the hook 71 by the supporting forces F_A of the spring element 20. The further the insert part 72 is arranged from the bearing point 22 the lower are the supporting forces F_A acting on the insert part 72. The insert part 72 can be made of metal, for example of steel, but also of synthetic material. An insert part 72 made of synthetic material has the advantage that vibrations within the fastening device are damped so that the operating noises of the escalator, moving walkway or lift can be minimised.

The insert part 72 further comprises a spreader wedge 72.2 which is formed by two lateral chamfers. When the spring element 20 is tensioned the two spring limbs 20.1, 20.2 thereof have to be detented from the starting position Y, which is indicated by dashed lines, in the two recesses 72.3, 73.4 formed at the insert part 72. The spreader wedge 72.2 facilitates spreading apart of the two spring limbs 20.1, 20.2 so that these can be lifted without difficulties over the lugs 72.5, 72.6 of the insert part 72 and detented in the recesses 72.3, 72.4.

Figure 9 shows a guide rail of a lift in three-dimensional view, which is arranged in a lift shaft (not illustrated). The lift cage and/or the compensating weight or counterweight is or are, for example, guided at this guide rail. The guide rail as attachment 80" is fastened to the shaft wall of the lift shaft by means of a component 90' in the form of a wall mount. The component 90' in turn comprises a fastening device 28. As in the case of the embodiments described in the preceding, a support point 91, a detent point 92 and a mounting receptacle 93 are formed at the component 90'. The detent point 92 is constructed by means of an S-shaped folding of a region of the component 90' bounded by two parallel sections. The component 90' additionally has an abutment point 94 for limitation of the freedom of movement of the attachment 80".

The illustrated spring element 95 differs from the spring elements of the embodiments described in the preceding by the fact that it has only one spring limb 95.1. The features such as clamping point 95.9, a lever end 95.4, a bearing point 95.2, a short lever arm 95.5 and a long lever arm 95.3 are also present in this spring element 95. In addition, the mode of functioning and the assembly sequence of this fastening device 28 correspond with the preceding embodiments.

Although the invention has been described by illustration of specific embodiments, it will be obvious that numerous further variants of embodiment can be created with knowledge of the present invention, for example by combining the features of the individual embodiments with one another and/or exchanging individual functional units of the embodiments. For example, the spring element can have only one spring limb in all embodiments. Obviously, in all embodiments use can be made of slide shoes, slide inserts, damping inserts, toothed profiles or profiles with sharp points and more of the same. It is also conceivable for an attachment, which is fastened to several components, to be connected with the components by differently designed fastening devices. For example, one of the fastening devices can have a toothed profile and all other fastening devices a slide shoe. Consequently, correspondingly designed fastening devices are embraced by the scope of protection of the present claims.

CLAIMS:

1. A component of an escalator a moving walkway or a lift, comprising:

a fastening device which includes

a spring element having a bearing point by which the spring element is pivotably arranged at the component and the spring element additionally includes a clamping point and a lever end, wherein a short lever arm is arranged between the bearing point and the clamping point and a long lever arm is arranged between the clamping point and the lever end,

a detent point for detenting the spring element and

a support point for support of an attachment to be fastened, wherein the spring element is pivotably arranged at the component, wherein in a stressed state the spring element is detented in the detent point and the attachment is pressed by the stressed spring element against the support point, and when the spring element is stressed the attachment is arranged between the support point and the clamping point.

2. A component of an escalator, a moving walkway or a lift, comprising:

a fastening device which includes a spring element, a detent point for detenting the spring element and a support point for support of an attachment to be fastened,

wherein the spring element is pivotably arranged at the component and is constructed with mirror symmetry with respect to its longitudinal direction and has a bearing point by which the spring element is pivotably arranged at the component, the spring element further including two spring limbs, wherein each spring limb has a clamping point and a lever end, a respective short lever arm is arranged between the bearing point and each clamping point and a respective long lever arm is arranged between the clamping points and the lever ends,

wherein in a stressed state the spring element is detented in the detent point and the attachment is pressed by the stressed spring element against the support point, and wherein the component is arranged between the spring limbs and when the spring element is stressed the attachment is arranged between the support point and the clamping points.

3. The component according to claim 1 or 2, wherein the clamping point of the spring element is formed by an angled fold.

4. The component according to any one of claims 1 to 3, wherein the long lever arm has at least twice the length of the short lever arm.
5. The component according to any one of claims 1 to 4, wherein the component is a support framework of an escalator or a moving walkway and the attachment is a frame or a module of an escalator or a moving walkway.
6. The component according to any one of claims 1 to 5, wherein the component is a frame or a module of an escalator or a moving walkway and the attachment is a track rail, running rail or guide rail.
7. The component according to any one of claims 1 to 4, wherein the component is a wall mount arranged in a lift shaft and the attachment is a running rail or guide rail of a lift cage and/or a compensating weight.
8. The component according to any one of claims 1 to 7, wherein the detent point is formed at the component.
9. The component according to any one of claims 1 to 8, wherein the detent point comprises an insert part.
10. The component according to any one of claims 1 to 9, wherein a spreader wedge is formed at the detent point.
11. The component according to any one of claims 1 to 10, wherein the detent point comprises a damping element.
12. The component according to any one of claims 1 to 11, wherein the support point comprises at least one abutment point for limitation of a direction of movement of the attachment.
13. The component according to any one of claims 1 to 12, wherein the support point comprises a slide surface, a slide insert or a slide shoe.

14. The component according to any one of claims 1 to 12, wherein the support point comprises anti-slip means.

15. The component according to any one of claims 1 to 14, wherein a reaction force (F_R) to external forces (F_S , F_Q) acting on the attachment is oriented in a same direction as a clamping force (F_F), which acts on the attachment, of the spring element.

FIG. 1

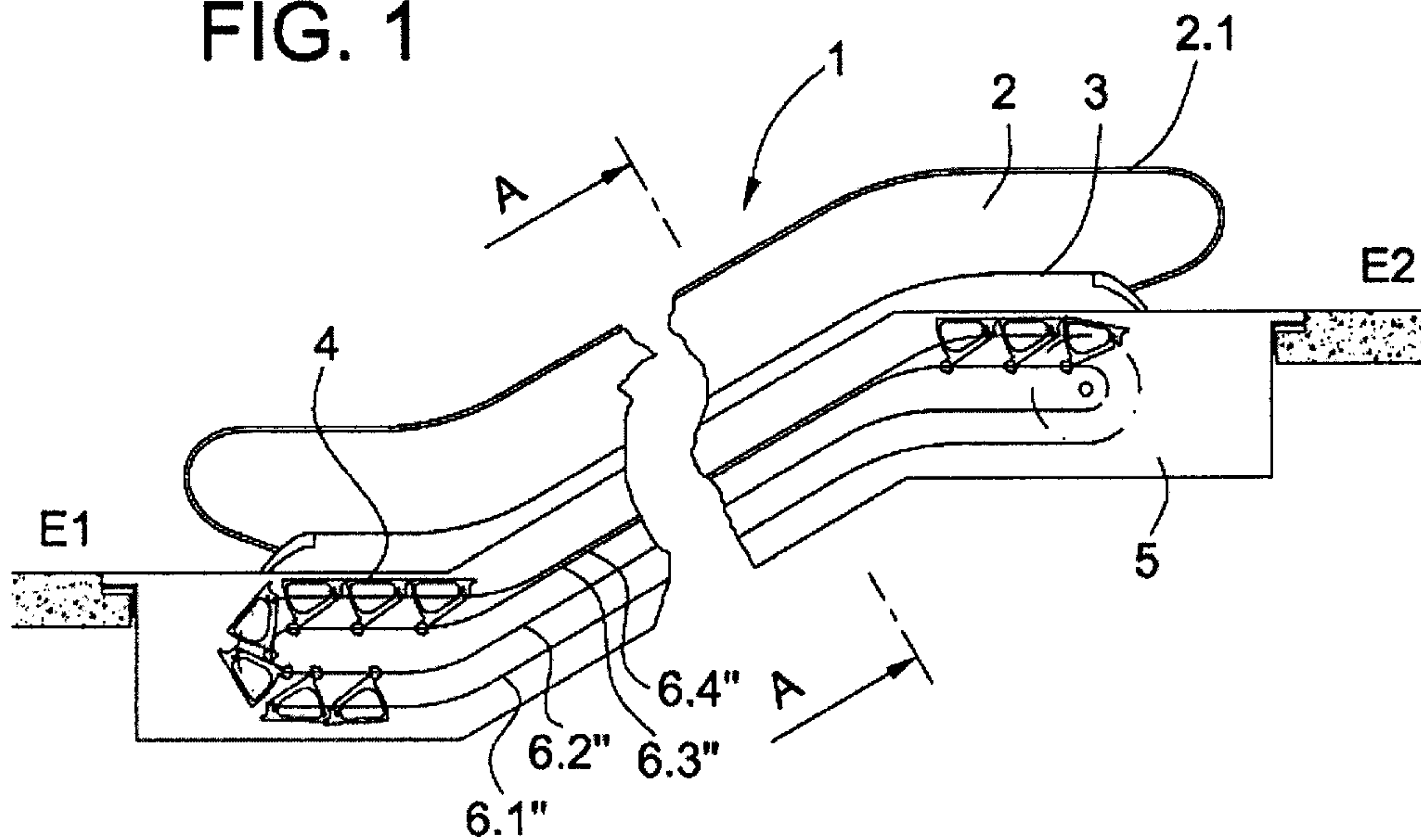

FIG. 2

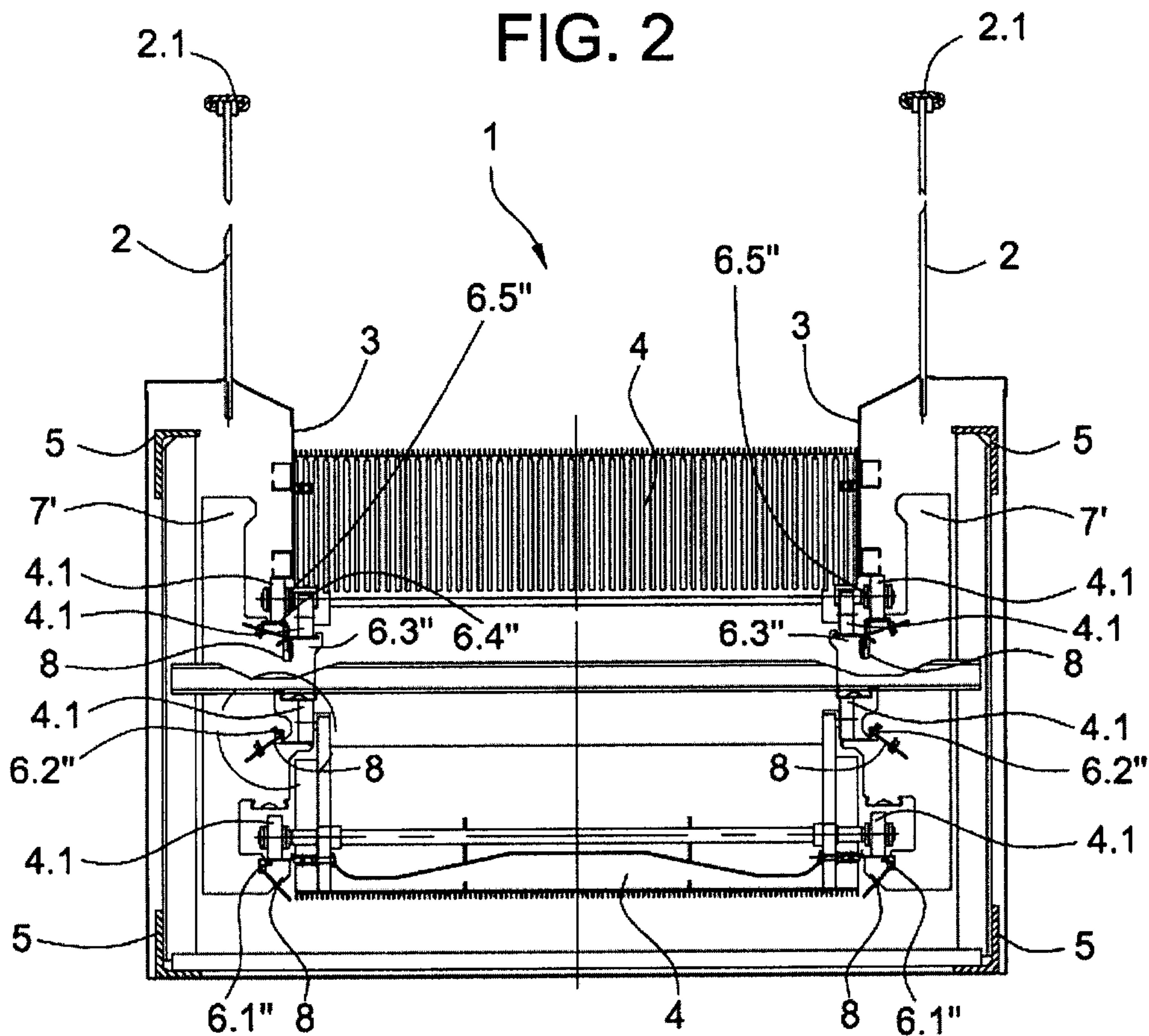

Fig. 3

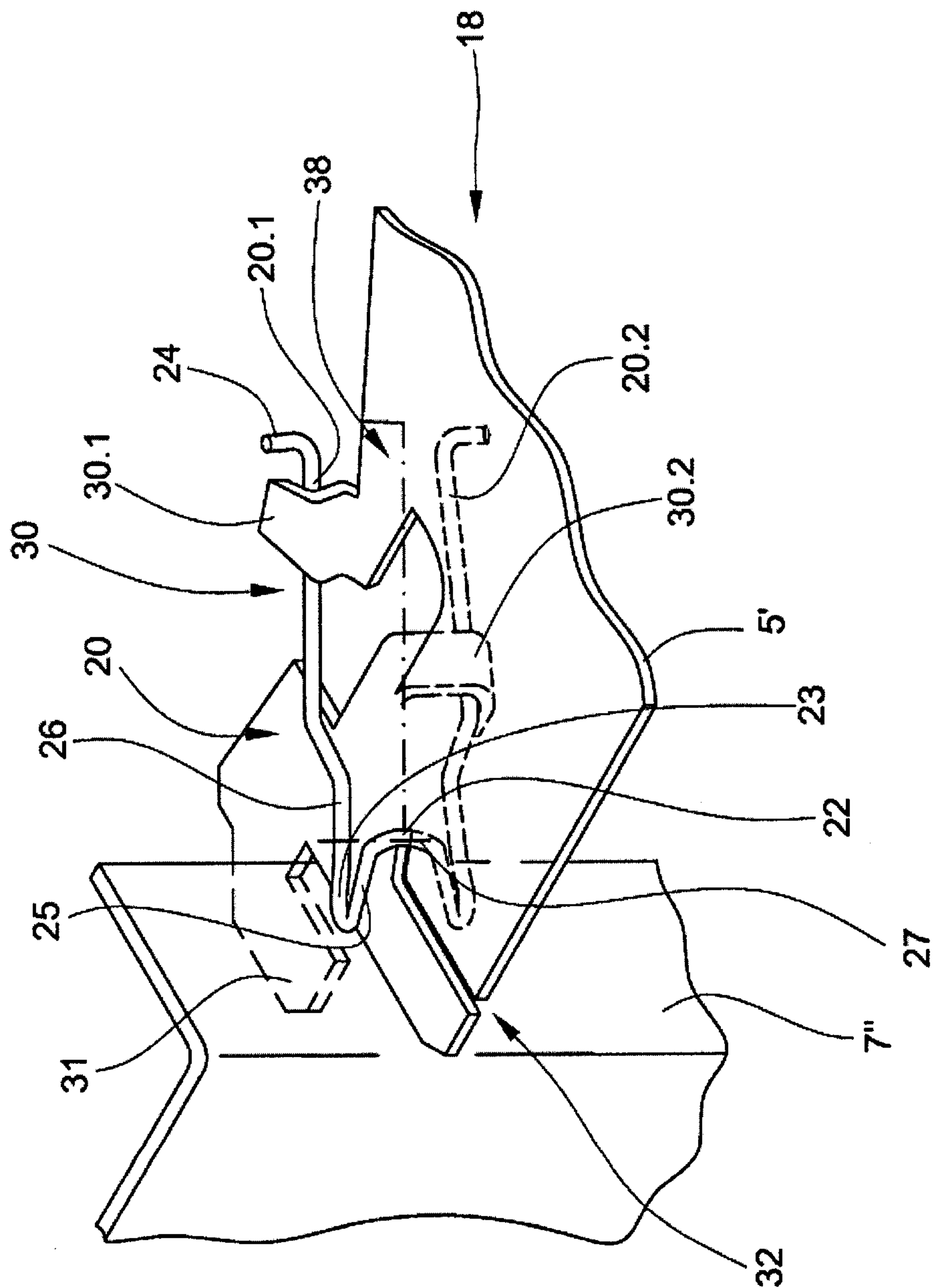

Fig. 4

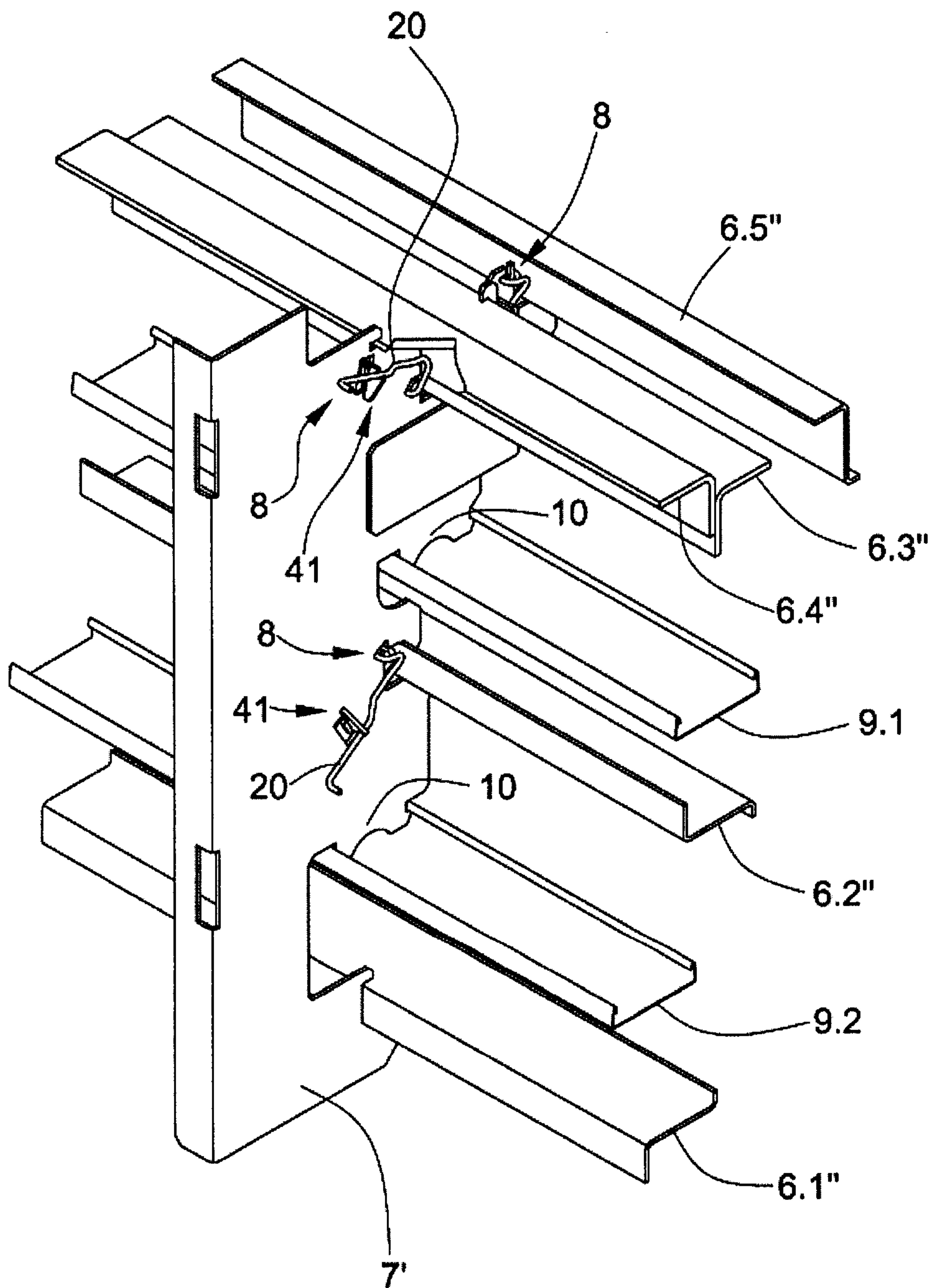

Fig. 6

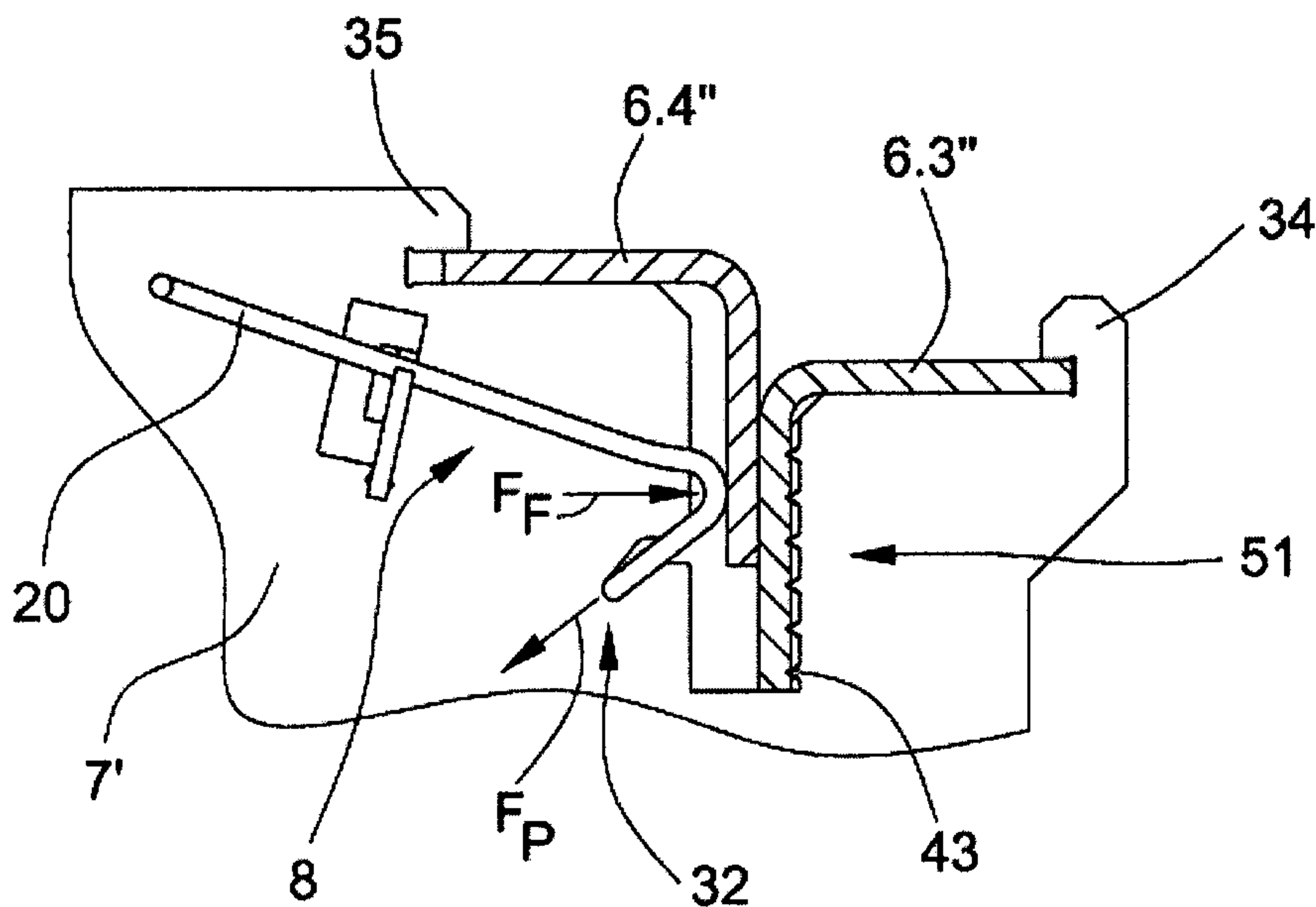

Fig. 7A

Fig. 7B

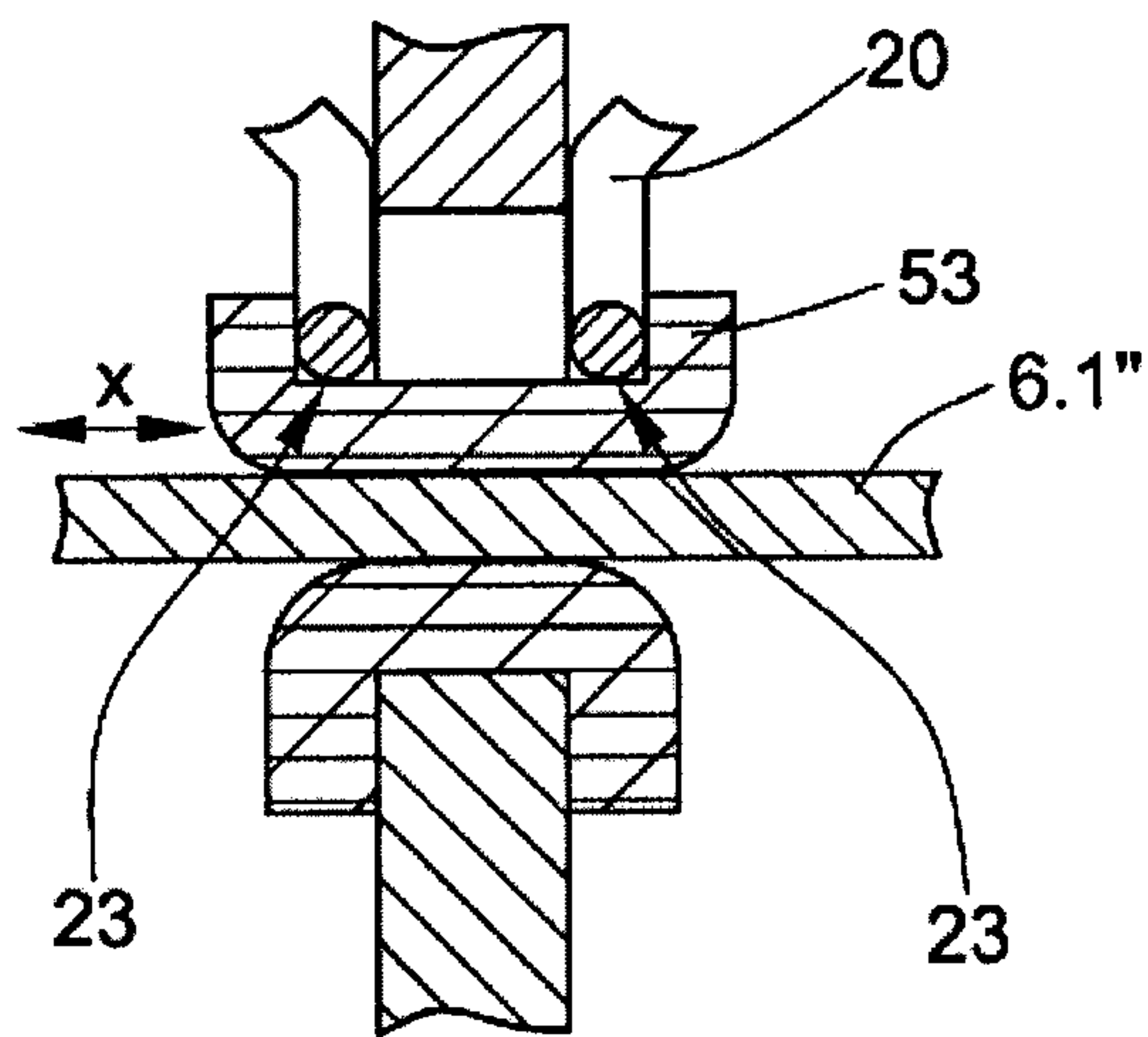
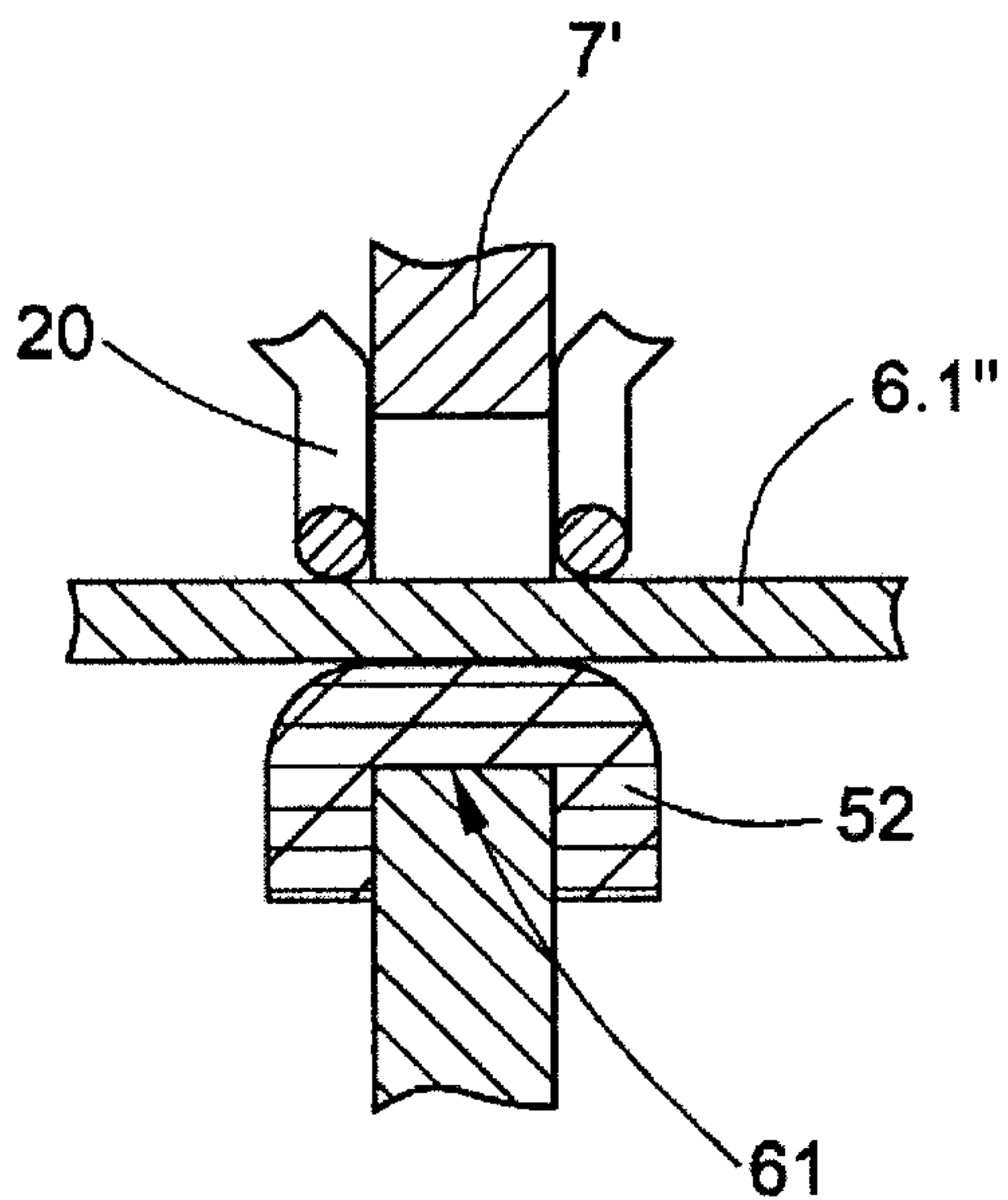

Fig. 8

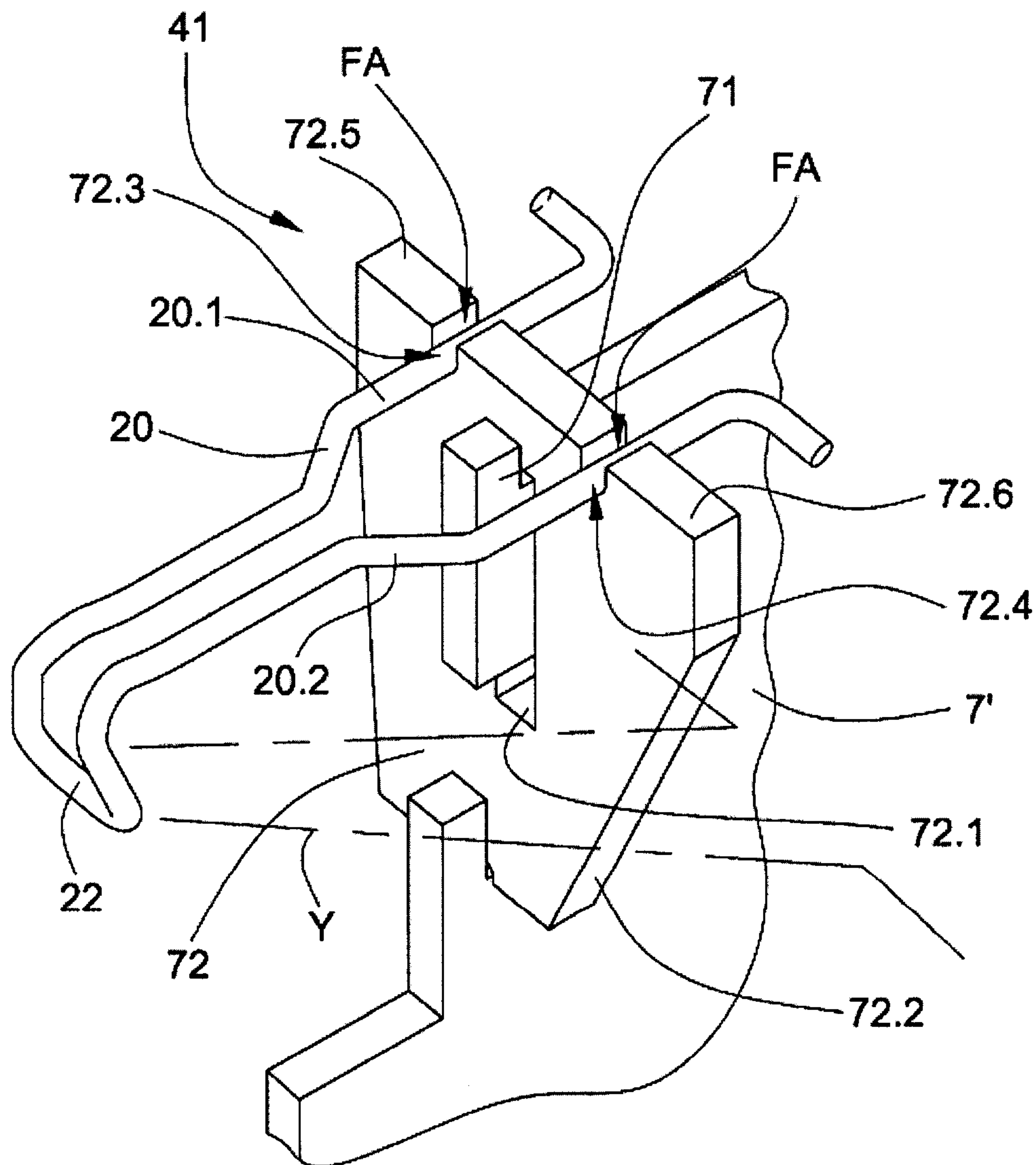

Fig. 9

