



US00D378229S

United States Patent [19]
Gayfer et al.

[11] **Patent Number: Des. 378,229**
[45] **Date of Patent: **Feb. 25, 1997**

- [54] **COMBINED DIRT COLLECTOR AND CUT-OUT COCK**
- [75] Inventors: **Robert P. Gayfer**, Watertown, N.Y.;
Martin A. Petzoldt, Hanover, Pa.
- [73] Assignee: **New York Air Brake Corporation**,
Watertown, N.Y.
- [**] Term: **14 Years**

Primary Examiner—Doris V. Coles
Assistant Examiner—Eric Watterson
Attorney, Agent, or Firm—Barnes & Thornburg

[57] **CLAIM**

The ornamental design for combined dirt collector and cut-out cock, as shown.

- [21] Appl. No.: **25,855**
- [22] Filed: **Jul. 14, 1994**
- [52] **U.S. Cl.** **D23/233**
- [58] **Field of Search** D23/233-237,
D23/244-249; 137/549; 210/452; 251/315.01

DESCRIPTION

- FIG. 1 is a front view of a combined dirt collector and cut-out cock according to the present invention;
- FIG. 2 is a back view;
- FIG. 3 is a right view;
- FIG. 4 is a left view;
- FIG. 5 is a top view; and,
- FIG. 6 is a bottom view.

- [56] **References Cited**
- U.S. PATENT DOCUMENTS**
- 3,748,837 7/1973 Billeter 137/549 X
- OTHER PUBLICATIONS**

Approval Test Specification for Combined Dirt Collector and Cut-Out Cock, Adopted 1982, Revised 1988, Association of American Railroads—Mechanical Division—Manual of Standards and Recommended Practices.

1 Claim, 3 Drawing Sheets

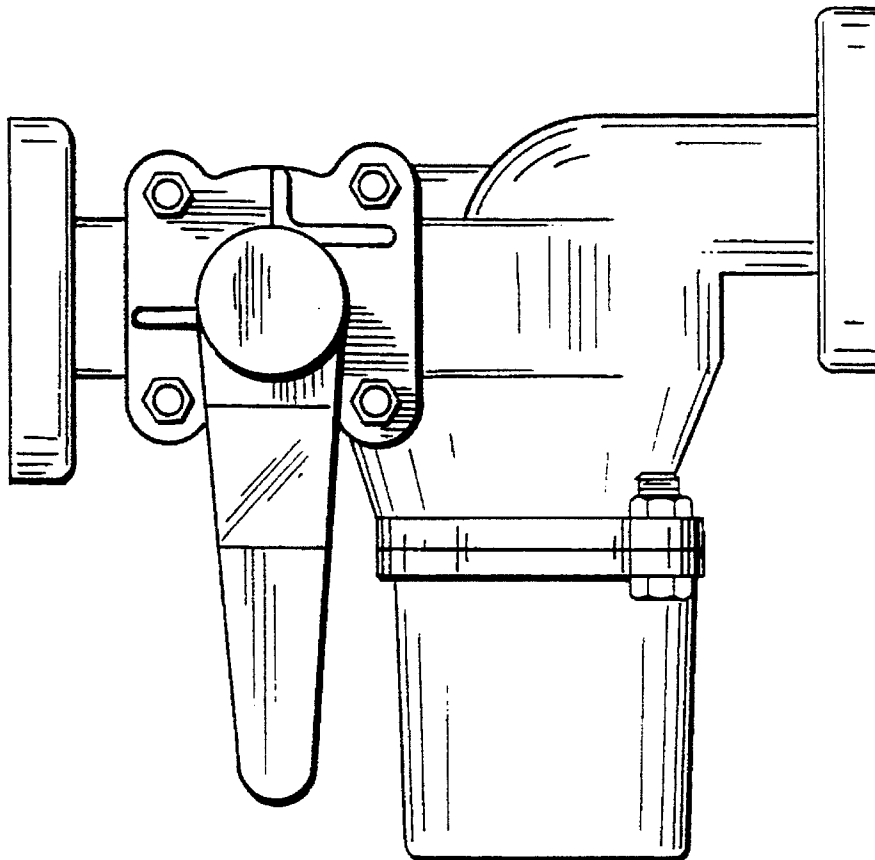

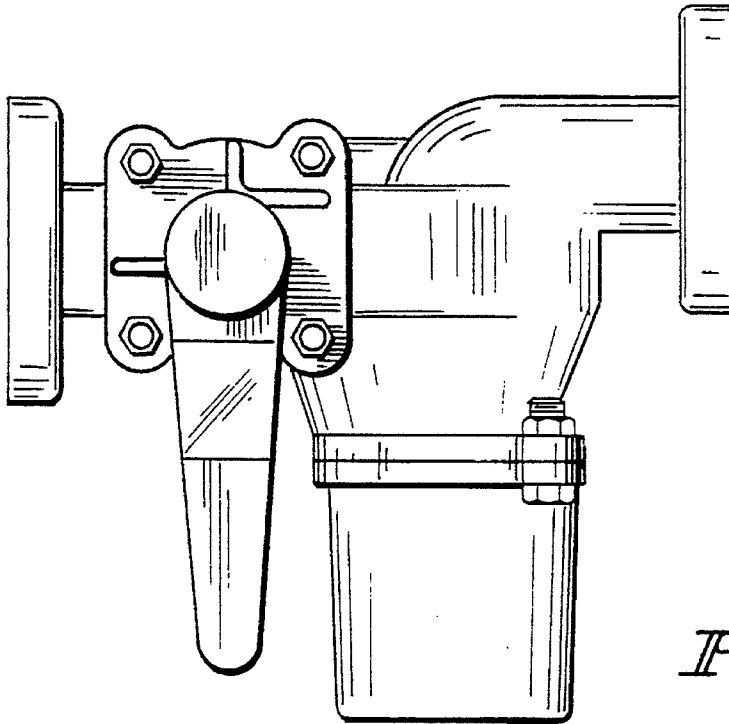

FIG. 1

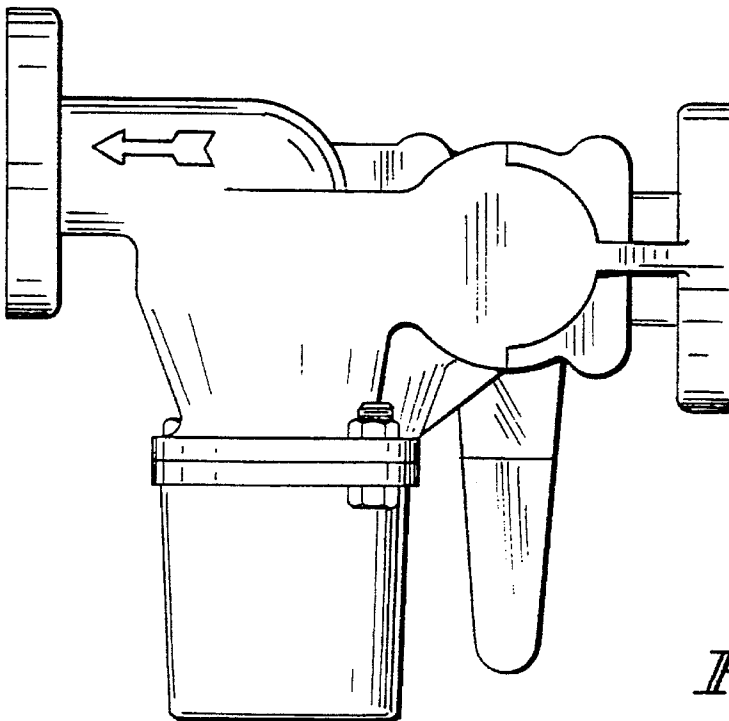

FIG. 2

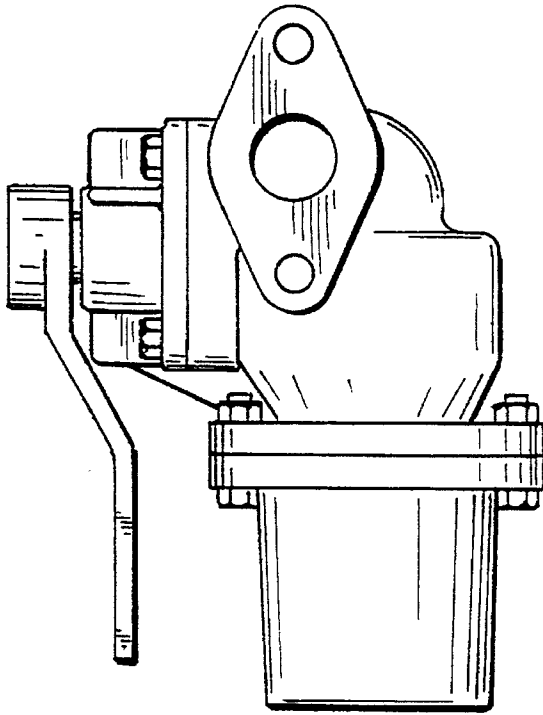

FIG. 3

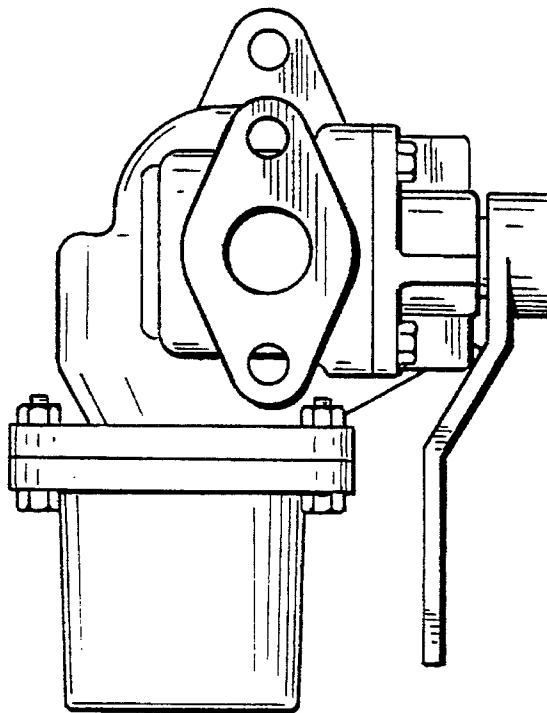

FIG. 4

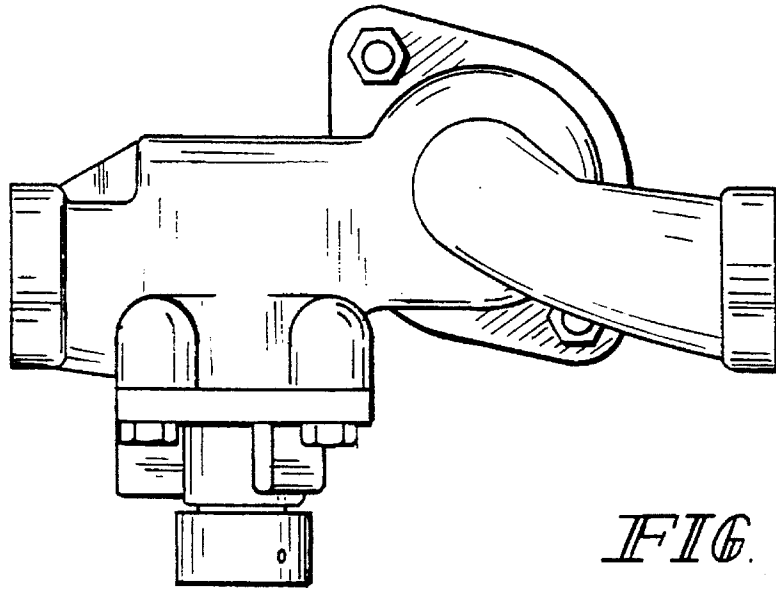

FIG. 5

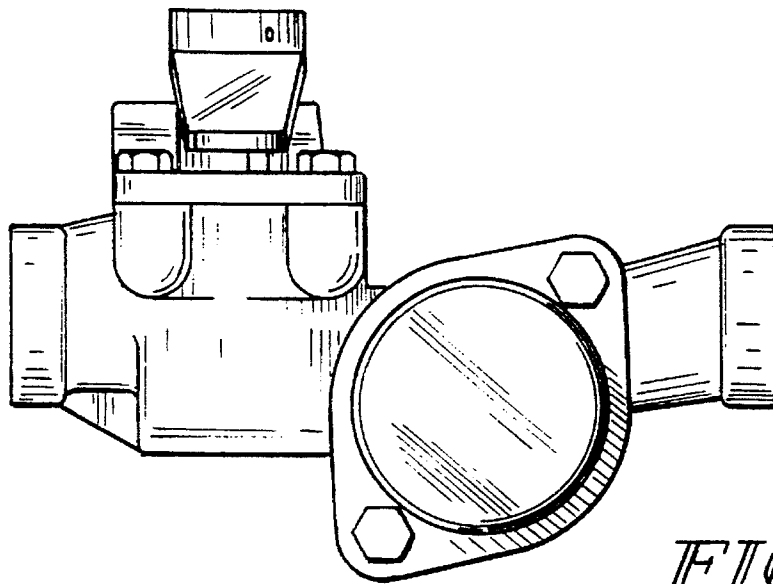

FIG. 6