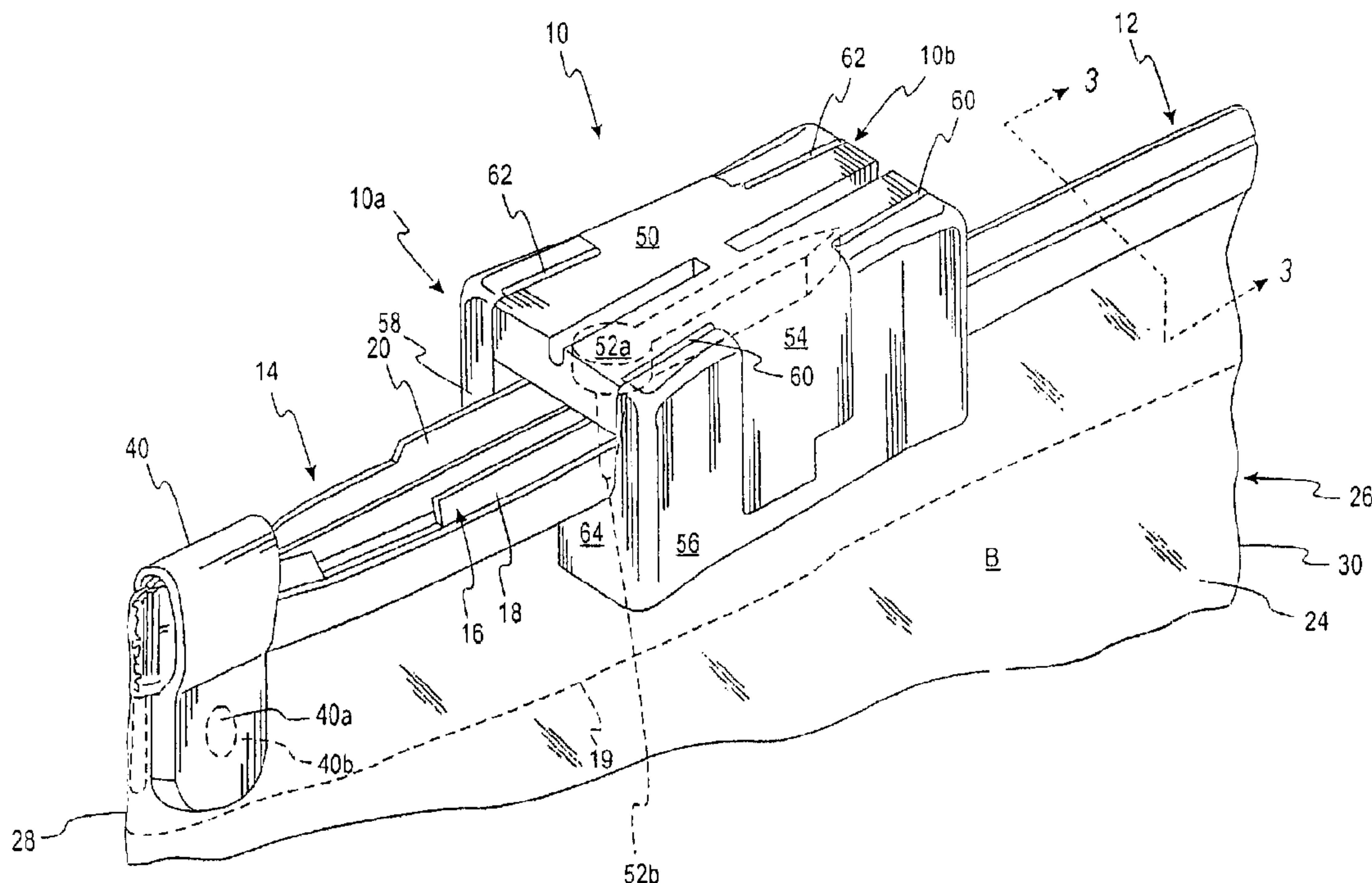




(22) Date de dépôt/Filing Date: 2003/02/26  
(41) Mise à la disp. pub./Open to Public Insp.: 2003/09/12  
(62) Demande originale/Original Application: 2 477 918  
(30) Priorité/Priority: 2002/03/01 (US60/361,171)

(51) Cl.Int./Int.Cl. *B65D 33/25* (2006.01),  
*A44B 19/16* (2006.01), *A44B 19/26* (2006.01),  
*B65D 33/16* (2006.01)  
(71) Demandeur/Applicant:  
PACTIV CORPORATION, US  
(72) Inventeurs/Inventors:  
DOBRESKI, DAVID V., US;  
FERRARI, DANIEL B., US;  
LONG, STEVEN P., US;  
THOMAS, TOBY R., US;  
BLYTHE, JAMES S., US;  
CAMERON, DAVID P., US  
(74) Agent: MARKS & CLERK

(54) Titre : SYSTEMES DE FERMETURE PAR PRESSION OU GLISSIERE REUTILISABLES POUR SACHETS  
POLYMERIQUES  
(54) Title: RECLOSABLE FASTENERS OF ZIPPERS FOR USE WITH POLYMERIC BAGS



(57) **Abrégé/Abstract:**

A slider (10) is adapted for use with a reclosable fastener (12) for bags containing material. The reclosable fastener includes a first track (14) and a second track (16). The first track (14) includes a first profile (18), while the second track (16) includes a second profile (20). The first and second profiles (18, 20) are releasably engageable to each other. At least one of the first and second profiles has an interior portion. The slider (10) comprises a body (50) that includes a top, a first side, a second side and a separation member (52a) on an underside of the top. The separation member (52a) is adapted to open and close the fastener and includes a slider finger (52b) that extends generally downwardly from the top. The slider finger extends into an interior portion of the first profile so as to assist in removing material trapped in the interior portion of the first profile when closing the reclosable fastener.

### **Abstract**

A slider (10) is adapted for use with a reclosable fastener (12) for bags containing material. The reclosable fastener includes a first track (14) and a second track (16). The first track (14) includes a first profile (18), while the second track (16) includes a second profile (20). The first and second profiles (18, 20) are releasably engageable to each other. At least one of the first and second profiles has an interior portion. The slider (10) comprises a body (50) that includes a top, a first side, a second side and a separation member (52a) on an underside of the top. The separation member (52a) is adapted to open and close the fastener and includes a slider finger (52b) that extends generally downwardly from the top. The slider finger extends into an interior portion of the first profile so as to assist in removing material trapped in the interior portion of the first profile when closing the reclosable fastener.

## RECLOSABLE FASTENERS OR ZIPPERS FOR USE WITH POLYMERIC BAGS

This is a divisional application of Canadian Patent Application 2,477,918 filed on February 26, 2003.

### FIELD OF THE INVENTION

The present invention relates generally to reclosable polymeric bags. More particularly, the present invention relates to improved fasteners or zippers for use with the polymeric bags. It should be understood that the expression "the invention" and the like encompasses the subject-matter of both the parent and the divisional applications.

### BACKGROUND OF THE INVENTION

Polymeric bags are popular household items that are used in a variety of applications including storage of food. The addition of reclosable fasteners or zippers to these bags has further enhanced their utility and the addition of a slider has made the fasteners easier to open and close. The fasteners include complementary first and second profiles that engage each other to close the polymeric bag.

There are a variety of food items that are desirable to store in these polymeric bags. Some desired items for storage include packaged material, such as particles or powders. This packaged material may include such items as sugar, salt, baby formula, coffee, pancake mix and dog food. Existing reclosable fastener or zipper bags, such as press to close bags and slider bags, often do not reclose after the packaged material is poured from the bag because the material gets trapped in an interior area of one or more of profiles. The trapped material can prevent or inhibit the first and second profiles from rolling or snapping together, resulting in the fastener not being able to reclose.

A need therefore exists for an improved reclosable fastener that reduces or eliminates the above-described problem of reclosing the first and second profiles after packaged material has been trapped therein.

### SUMMARY OF THE INVENTION

According to one embodiment, a slider is adapted for use with a reclosable fastener for bags containing material. The reclosable fastener includes a first track and a second track. The first track includes a first profile, while the second track includes a second profile. The first and second profiles are releasably engageable to each other. At least one of the first and second profiles has an interior portion. The slider comprises a body that includes a top, a first slide, a second slide and a separation member on a

underside of the top. The separation member is adapted to open and close the fastener and includes a first slider finger and a second slider finger. The first slider finger extends generally downwardly from the top. The first slider finger extends into an interior portion of the first profile so as to assist in removing material trapped in the interior portion of the first profile when closing the reclosable fastener. The second slider finger extends generally downwardly from the top. The second slider finger extends into an interior portion of the second profile so as to assist in removing material trapped in the interior portion of the second profile when closing the reclosable fastener.

According to one embodiment, a reclosable fastener is adapted for use with bags having an interior space adapted to receive material. The reclosable fastener comprises a first track and a second track. The first track includes a first profile, first fin portion and a first fin flap. The second track includes a second profile, a second fin portion and a second fin flap. The first and second profiles are releasably engageable to each other. The first fin portion extends generally downwardly from the first profile toward the interior space of the bag. The second fin portion extends generally downwardly from the second profile toward the interior space of the bag. The first fin flap is attached to the first fin and extends upwardly and outwardly to the second profile so as to prevent or inhibit material from entering one of more interior areas of the first and second profiles. The second fin flap is attached to the second fin portion and extends upwardly and outwardly to the first profile so as to prevent or inhibit material from entering one of more interior areas of the first and second profiles.

According to another embodiment, a reclosable fastener is adapted for use with bags having an interior space adapted to receive material. The reclosable fastener comprises a first track and a second track. The first track includes a first profile, and a first fin portion. The second track includes a second profile, a second fin portion and a first fin flap. The first and second profiles are releasably engageable to each other. The first fin portion extends generally downwardly from the first profile toward the interior space of the bag. The second fin portion extends generally downwardly from the second profile toward the interior space of the bag. The first fin flap is attached to the second fin portion and extends upwardly and outwardly to the first profile so as to prevent or inhibit material from entering one of more interior areas of the first and second profiles.

According to a further embodiment, a reclosable fastener is adapted for use with bags having an interior space adapted to receive material. The reclosable fastener comprises a first track and a second track. The first track includes a first profile that has an interior area, while the second track includes a second profile. The first and second profiles are releasably engageable to each other. The first profile has a thin walled deflection shield that prevents or inhibits material from entering the interior area of the first profile. A portion of the thin walled deflection shield is adapted to break, rupture or slit in response to a portion of the second profile entering the interior area of the first profile. The thin walled deflection shield may be formed by a seam portion.

According to yet another embodiment, a reclosable fastener is adapted for use with bags having an interior space adapted to receive material. The reclosable fastener comprises a first track and a second track. The first track includes a first profile, while the second track includes a second profile. The first and second profiles are releasably engageable to each other. The first profile is a general c-shape and further includes two thin walled deflection shields. The general c-shape is formed from two extensions spaced apart and attached to a first portion. The two extensions has two outer ends spaced from the first portion. Each of the two thin walled deflection shields is attached near a respective one of the two outer ends of the two extensions so as to prevent or inhibit material from entering the interior area of the first profile. The thin walled deflection shields are spaced slightly apart so as to allow a portion of the second profile to enter into the interior area formed by the general c-shape section.

According to yet a further embodiment, a reclosable fastener is adapted for use with bags having an interior space adapted to receive material. The reclosable fastener comprises a first track and a second track. The first track includes a first profile, while the second track includes a second profile. The first profile includes a gasket formed in an interior area thereof. The gasket is adapted to prevent or inhibit material from entering the interior area of the first profile and/or expel material from the interior area of the first profile. The first and second profiles are releasably engageable to each other and the gasket is compressed upon engagement of the first and second profiles.

3a

In one aspect, the invention provides a reclosable fastener for use with bags having an interior space adapted to receive material, the reclosable fastener comprising:

a first track comprising a first profile, first fin portion and a first fin flap, the first fin portion extending generally downwardly from the first profile, the first fin flap being attached to the first fin and extending upwardly and outwardly toward the interior of the bag so as to prevent or inhibit material from entering at least one interior area of the first profile and a second profile; and

a second track comprising the second profile, a second fin portion and a second fin flap, the first and second profiles being releasably engageable to each other, the second fin portion extending generally downwardly from the second profile, the second fin flap being attached to the second fin portion and extending upwardly and outwardly toward the interior space of the bag so as to prevent or inhibit material from entering at least one interior area of the first and second profiles; and

a slider configured to operate on the first and second tracks, the slider being slidable along the first and second tracks from an open position to a closed position, in which the first and second profiles are disengaged when the slider is in the open position and engaged when the slider is in the closed position.

In one aspect, the invention provides a reclosable fastener for use with bags having an interior space adapted to receive material, the reclosable fastener comprising:

a first track comprising a first profile, and first fin portion, the first fin portion extending generally downwardly from the first profile;

a second track comprising a second profile, a second fin portion and a first fin flap, the first and second profiles being releasably engageable to each other, the second fin portion extending generally downwardly from the second profile, the first fin flap being attached to the second fin portion and extending upwardly and outwardly toward the interior space of the bag so as to prevent or inhibit material from entering at least one interior area of the first and second profiles; and

3b

a slider configured to operate on the first and second tracks, the slider being slidable along the first and second tracks from an open position to a closed position, in which the first and second profiles are disengaged when the slider is in the open position and engaged when the slider is in the closed position.

- 5 In one aspect, the invention provides a reclosable fastener for use with bags having an interior space adapted to receive material, the reclosable fastener comprising:
- a first track comprising a first profile, the first profile being a general c-shape and further including two generally thin walled deflection shields, the general c-shape being formed from two extensions spaced apart and attached to a first portion, the two
  - 10 extensions having respective outer ends each spaced from the first portion, each of the two generally thin walled deflection shields being attached near a respective one of the outer ends of the two extensions so as to prevent or inhibit material from entering the interior area of the first profile;
  - a second track comprising a second profile, the first and second profiles being releasably
  - 15 engageable to each other; and
  - a slider configured to operate on the first and second tracks, the slider being slidable along the first and second tracks from an open position to a closed position, in which the first and second profiles are disengaged when the slider is in the open position and engaged when the slider is in the closed position;
  - 20 wherein the generally thin walled deflection shields are spaced slightly apart so as to allow a portion of the second profile to enter into the interior area formed by the general c-shape section.

- In one aspect, the invention provides a reclosable fastener for use with bags having an interior space adapted to receive material, the reclosable fastener comprising:
- 25 a first track comprising a first profile, the first profile including a resilient gasket formed in an interior area thereof, the gasket extending near an opening to the interior area so as

3c

to prevent or inhibit material from entering the interior area of the first profile and/or expel material from the interior area of the first profile; and

a second track comprising a second profile, the first and second profiles being releasably engageable to each other;

- 5 wherein the gasket is compressed from an initial position upon engagement of the first and second profiles, and substantially returns to the initial position when the first and second profiles are disengaged.

In one aspect, the invention provides a reclosable fastener for a bag adapted to contain material, the reclosable fastener comprising:

- 10 a first track including a first profile, the first profile having an interior portion;  
a second track including a second profile, the second profile having an interior portion, the first and second profiles being releasably engageable to each other; and  
a slider engaging the first and second tracks, the slider comprising a body including a top, a first side, a second side and a separation member on an underside of the top, the  
15 separation member being adapted to open and close the first and second tracks and comprising a first slider finger and a second slider finger, the first slider finger extending generally downwardly from the top of the body and the first slider finger extending into an interior portion of the first profile so as to assist in removing material trapped in the interior portion of the first profile when closing the reclosable fastener, the second slider  
20 finger extending generally downwardly from the top and the second slider finger extending into an interior portion of the second profile so as to assist in removing material trapped in the interior portion of the second profile when closing the reclosable fastener.

In one aspect, the invention provides a reclosable fastener for a bag adapted to  
25 contain material, the reclosable fastener comprising:

a first track including a first profile, the first profile having an interior portion;



3d

a second track including a second profile, the second profile having an interior portion, the first and second profiles being releasably engageable to each other; and

a slider engaging the first and second tracks, the slider comprising a body including a top, a first side, a second side and a separation member on an underside of the top, the separation member being adapted to open and close the first and second tracks and comprising a first slider finger and a second slider finger, the first slider finger extending generally downwardly from the top of the body and the first slider finger extending into and substantially filling an interior portion of the first profile so as to assist in removing material trapped in the interior portion of the first profile when closing the reclosable fastener, the second slider finger extending generally downwardly from the top and the second slider finger extending into an interior portion of the second profile so as to assist in removing material trapped in the interior portion of the second profile when closing the reclosable fastener.

In one aspect, the invention provides a method of using a reclosable fastener for a bag adapted to contain material, the method comprising:

providing a first track and a second track, the first track including a first profile, the second track including a second profile, the first and second profiles being releasably engageable to each other, each of the first and second profiles having an interior portion;

providing a slider engaging the first and second tracks, the slider comprising a body including a top, a first side, a second side and a separation member on an underside of the top, the separation member being adapted to open and close the fastener and comprising a first slider finger and a second slider finger, the first slider finger extending generally downwardly from the top of the body, the second slider finger extending generally downwardly from the top; and

grasping the slider and moving the slider on the first and second tracks of a bag such that the first slider finger extends into an interior portion of the first profile and assists in removing material trapped in the interior portion of the first profile when closing the

3e

reclosable fastener, and the second slider finger extends into an interior portion of the second profile and assists in removing material trapped in the interior portion of the second profile when closing the reclosable fastener.

In one aspect, the invention provides a reclosable fastener for use with bags  
5 having an interior space adapted to receive material, the reclosable fastener comprising:  
a first track comprising a first profile, first fin portion and a first fin flap, the first fin  
portion extending generally downwardly from the first profile, the first fin flap being  
attached to the first fin and extending upwardly and outwardly toward the interior of the  
bag so as to prevent or inhibit material from entering at least one interior area of the first  
10 and second profiles; and  
a second track comprising a second profile, a second fin portion and a second fin flap,  
the first and second profiles being releasably engageable to each other, the second fin  
portion extending generally downwardly from the second profile, the second fin flap  
being attached to the second fin portion and extending upwardly and outwardly toward  
15 the interior space of the bag so as to prevent or inhibit material from entering at least one  
interior area of the first and second profiles;  
wherein the first fin flap and the second fin flap extend upwardly and outwardly toward  
the interior space of the bag such that during the engagement of the first and second  
profiles, the first fin flap and the second fin flap are located entirely beneath the first and  
20 second profiles in a non-interlocked position.

**BRIEF DESCRIPTION OF THE DRAWINGS**

FIG. 1 is a perspective view of a thermoplastic bag having a fastener and slider.

FIG. 2 is an enlarged perspective view of a slider on a bag constructed in accordance with one embodiment of the present invention.

5 FIG. 3 is a cross-sectional view of the fastener of FIGS. 1 and 2 taken generally along line 3-3 in FIG. 2.

FIG. 4 is an end view of a slider with a generally straight finger according to one embodiment of the present invention.

FIG. 5 is an end view of a the slider of FIG. 4 with first and second profiles  
10 according to one embodiment of the present invention.

FIG. 6 is an end view of the slider with an angled finger according to another embodiment of the present invention.

FIG. 7 is an end view of the slider of FIG. 6 with first and second profiles according to another embodiment of the present invention.

15 FIG. 8 is an end view of a slider with an enlarged radiused finger according to yet another embodiment of the present invention.

FIG. 9 is an end view of the slider of FIG. 8 with first and second profiles according to yet another embodiment of the present invention.

FIG. 10 is an end view of a slider with a longer finger, and first and second  
20 profiles according to an embodiment of the present invention.

FIG. 11 is end view of a slider with a wider finger, and first and second profiles according to another embodiment of the present invention.

FIG. 12 is an end view of a slider according to yet another embodiment of the present invention.

25 FIGS. 13a, b are perspective views of the slider of FIG. 12.

FIG. 14 is an end view of a portion of the slider of FIG. 12 with first and second profiles.

FIG. 15 is a top perspective view of a portion of the slider of FIG. 12 with first and second profiles.

30 FIG. 16 is an elastomeric female track and a male track according to an embodiment of the present invention.

FIG. 17 is the elastomeric female track of FIG. 16 with an elastomeric profile portion in a first position.

FIG. 18 is the elastomeric track and the male track of FIG. 16 in an interlocking position with the elastomeric profile portion in a second position.

5 FIG. 19 is an elastomeric female track and a male track according to a further embodiment of the present invention.

FIG. 20 is the elastomeric female track of FIG. 19 with an elastomeric profile portion in a first position.

10 FIG. 21 is the elastomeric female track and the male track of FIG. 19 in an interlocking position with the elastomeric profile portion in a second position.

FIG. 22a is a female track and a male track with respective fin flaps according to one embodiment of the present invention.

FIG. 22b is a female track and a male track with respective fin flaps according to another embodiment of the present invention.

15 FIG. 22c is a female track and a male track with a fin flap according to another embodiment of the present invention.

FIG. 23 is a female profile with a generally thin-walled section according to a further embodiment of the present invention.

20 FIG. 24 is the female profile of FIG. 23 shown in an interlocking position with a male profile.

FIG. 25 is the female profile of FIG. 23 after the male profile has been in an interlocking position thereto.

FIG. 26 is a female profile with a gasket portion according to yet a further embodiment of the present invention.

25 FIG. 27 is the female profile of FIG. 26 shown in an interlocking position with a male profile.

FIG. 28 is a side view of a polymeric bag and a fastener or zipper with two male profiles and two female profiles according to an embodiment of the present invention.

30 FIG. 29 is a cross sectional view of the respective male and female profiles of FIG. 28 in an interlocked position.

FIG. 30 is a side view of a polymeric bag and a fastener or zipper with two male profiles and two female profiles according to another embodiment of the present invention.

While the invention is susceptible to various modifications and alternative forms, specific embodiments thereof have been shown by way of example in the drawings and will herein be described in detail. It should be understood, however, that it is not intended to limit the invention to the particular forms disclosed but, on the contrary, the intention is to cover all modifications, equivalents, and alternatives falling within the spirit and scope of the invention as defined by the appended claims.

#### 5 DETAILED DESCRIPTION OF THE ILLUSTRATED EMBODIMENT

Referring to FIG. 1, there is illustrated a polymeric slider 10 and a profiled polymeric fastener or zipper 12. The slider 10 and fastener 12 are particularly suited for thermoplastic bags and the like. It is contemplated that the slider and fastener may be used with other bags such as multi-walled paper bags. Slider 10 has been illustrated in  
10 FIG. 2 assembled on the fastener 12 at the top edge or mouth of a thermoplastic bag B. The slider 10 and the fastener 12 cooperate to close the bag B. To assist in opening the bag, the slider 10 is slidably mounted to the fastener 12 for movement between a closed position and an open position.

Bag B (as shown in FIGs. 1 and 2) is formed from a single flexible polymeric sheet  
15 folded upon itself and comprises first and second opposing body panels 24, 26. Body panels 24, 26 are fixedly connected to each other along a pair of sides 28, 30 and a bottom 32 which extends between the pair of sides 28, 30. The fastener 12 extends along the top edge or mouth formed opposite the bottom 32 of bag B, in which the fastener 12 has a male track 14 and a female track 16.

20 Alternatively, bag B may be formed from separate polymeric sheets where the first and second opposing body panels are sealed after being initially separated so as to form the pair of sides and the bottom (*i.e.*, sealed on three sides). Alternatively, bag B may be formed from a single flexible plastic sheet having a side fold, a seal on the side opposite the side fold, and an end seal (not shown).

Alternatively, bag B (not shown) may be a stand-up polymeric bag that comprises first and second opposing body panels, a bottom wall and a reclosable feature or fastener, such as a reclosable zipper which can be opened and closed either by the use of an auxiliary slider mechanism, by finger pressure, or by an auxiliary squeezing device other than an auxiliary slider mechanism. The first and second opposing body panels are coupled to opposing portions of the bottom wall. The bottom wall may be a gusseted bottom wall comprising gusseted portions or may be comprised of configurations other than a gusseted bottom wall. One example of a stand-up polymeric bag is shown in U.S. Patent No. 6,148,588 to Thomas et al. It is contemplated that the bag may be a side-gusseted bag.

The body panels 24, 26 typically comprise one or more polymeric resins. The body panels 24, 26 may be comprised of polyolefins including, but not limited to, polyethylene, polypropylene or combinations thereof.

Referring to FIGs. 2 and 3, the fastener 12 comprises the male track 14 and the female track 16. The male and female tracks 14, 16 include respective male and female profiles 18, 20. The male and female profiles 18, 20 are interlocking and extend the length thereof in the form of rib and groove elements on the respective tracks. The tracks 14, 16 may be extruded separately with a fin and attached to the respective sides of the bag mouth or the tracks 14, 16 may be extruded integral with the sides of the bag mouth. If the tracks 14, 16 are extruded separately, they are most effectively attached by means of a respective male and female fins, incorporated within the tracks, that is heat sealed to a bag mouth.

The fastener 12 typically comprises one or more polymeric resins. The fastener may be comprised of polyolefins including, but not limited to, polyethylene, polypropylene or combinations thereof.

Referring specifically to FIG. 3, the male track 14 includes the male profile 18 and a first depending fin or flange 19, extending downward from the male profile 18. Likewise, the female track 16 includes the female profile 20 and a second depending fin or flange 21 extending downward from the female profile 20. The fins 19, 21 are shown attached to the opposing body panels 24, 26 in FIG. 3. The opposing body panels 24, 26 may be attached to the inner surfaces of respective fins 19, 21 as shown in FIG. 3 or may

be attached to outer surfaces of respective fins 19, 21 (not shown). The male and female profiles 18, 20 have complementary cross-sectional shapes. The cross-sectional shapes of the interlocking male and female profiles 18, 20 shown in FIG. 3 are also shown in U.S. Patent No. 5,007,143 to Herrington.

5 In the open position of the slider 10, the male and female profiles 18, 20 are disengaged from each other so that a user can gain access to the interior of the bag B. Movement of the slider 10 from the open position to the closed position interlocks the male and female profiles 18, 20 so as to restrict access to the interior of the bag B. For example, the male and female profiles 18, 20 may be rolled or pressed into their  
10 interlocking arrangement so as to securely close the bag B by one of two means. First, the tracks may be rolled or pressed together at one end by a user and then sequentially fitted together along the length of the fastener by a user running a finger along the length of the fastener on each side of the tracks. Alternatively, some bags employ a polymeric slider that rides along the tracks of the fastener. If the slider is pulled in one direction, the  
15 bag is sealed shut; if the slider is pulled in the opposite direction, the bag is reopened. As may be seen in FIG. 2, the slider 10 straddles the fastener 12 at the top of the bag B and is adapted for opening or closing the interlocking tracks 14, 16 of the fastener 12.

The opposite ends of the fastener 12 are typically provided with opposing end terminations. One example of an end termination is end termination clip 40 depicted in  
20 FIGs. 1-2. Each end clip 40 comprises a strap member which wraps over the top of the fastener 12. One end of the strap is provided with a rivet like member 40a which is adapted to penetrate through the bag material and into a cooperating opening 40b at the other end of the clip 40. The rivet 40a is then deformed so as to create a head locked into the opening 40b.

25 End terminations may have various purposes such as (a) preventing or inhibiting the slider 10 from going past the ends of the fastener 12, (b) interacting with the slider 10 to give a tactile indication of being closed, (c) assisting in inhibiting or preventing leakage from the bag B and (d) holding the male and female profiles 18, 20 together and providing additional strength in resisting stresses applied to the profiles 18, 20 during normal use of  
30 the bag B. Further details concerning the construction and operation of the slider 10 and

the end clips 40 may be obtained from United States Patent No. 5,067,208 to Herrington, Jr. et al.

It is contemplated that other end terminations may be used instead of the above-described end terminations clip 40. For example, an end weld may be formed by heated bars pressed against the end of the fastener, ultrasonic welding or other ways known in the art.

#### Improved Sliders

According to one embodiment of the present invention, a slider is adapted to remove packaged material, such as particles or powder, that has been trapped in an interior area of one or more of the tracks. The slider includes a slider finger that removes the packaged material that has been trapped in an interior area out of one or more of the profiles. The removal of the trapped material increases the likelihood of reclosing the pouch or bag (e.g., a stand-up bag).

Referring initially to FIG. 4, there is illustrated the slider 10 according to one embodiment of the present invention. The slider 10 may be a unitary or integral structure (i.e., a one-piece slider). The slider 10 is an inverted generally U-shaped member. The sliders of the present invention may be combined with the fastener or zipper 12 in forming the thermoplastic bag B (see FIGs. 1-2).

As shown in FIG. 2, the slider 10 comprises an inverted generally U-shaped member including a transverse support member or body 50 from which a torpedo 52a and generally straight slider finger 52b extend generally downward. The body 50 is itself U-shaped and includes two integral legs 54 extending generally downward. The generally straight finger 52b and torpedo 52a are positioned between the legs 54. It is contemplated the generally straight finger and torpedo may be located in front of the legs (i.e., at an end of the slider closer to end termination 40). The body 50 is adapted to move along the top edges of the tracks 14, 16 with the legs 54 straddling these elements and the torpedo 52a positioned between the tracks 14, 16. The slider 10 also includes a pair of hinged "wings" 56, 58 that can be folded down into their final position. The wings 56, 58 are hinged to the main slider body 50 by means of hinge structures 60, 62 located at opposite ends of the legs 54. It is contemplated that the slider does not necessarily have to be a hinged structure.



The foldable depending wings or side walls 56, 58 extend from an opening end 10a of the slider 10 to a closing end 10b. It is noted that the body 50 and the torpedo 52a are wider at the opening end 10a than at the closing end 10b. Similarly, the side walls 56, 58 and the legs 54 are spaced wider apart at the opening end 10a of the slider 10 to permit separation of the male and female profiles 18, 20 by the torpedo 52a engaging the tracks 14, 16. The wings 56, 58 and legs 54 are spaced sufficiently close together at the closing end 10b of the slider to press the male and female profiles 18, 20 into an interlocking relationship as the slider 10 is moved in a fastener closing direction.

As shown in FIG. 2, the wings 56, 58 at their lower ends are each provided with an inwardly extending shoulder structure 64. The shoulder structures 64 engage a bottom of the fastener 12 to prevent or inhibit the slider 10 from being lifted off the edges of the tracks 14, 16 while the slider 10 straddles the fastener 12. Specifically, the shoulder structures 64 engage with lower surfaces of the profiles to inhibit or prevent the slider from being (a) pulled off in a direction perpendicular to the sliding motion and (b) removed from the force required to open the profiles.

The torpedo 52a has a wide portion 53 (FIG. 5) and a narrow portion (not shown). The torpedo 52a with the wide and narrow portions interact with first and second portions 22, 23 (FIG. 5) of the fastener 12 to lock and unlock the male and female profiles 18, 20 of the fastener 12. This interaction opens and closes the fastener 12 in the manner described in United States Patent No. 5,007,143. More specifically, the wide portion 53 of the torpedo 52a in cooperation with the shoulder structures 64 spread the first and second portions 22, 23. The spread first and second portions 22, 23 separate the male and female profiles 18, 20, thereby opening the fastener 12 (FIG. 2) as the slider 10 is moved.

To close the fastener 12, the slider 10 is moved in the reverse direction and the narrow portion of the torpedo 52a cooperates with the shoulder structures 64 and the sides of the slider 10 to bring the first and second portions 22, 23 together. The first and second portions 22, 23 when brought together lock the male and female profiles 18, 20 (FIG. 3). To close the fastener 12 completely, at least the wide portion 53 of the torpedo 52a is removed from between the first and second portions 22, 23 of the fastener 12.

Referring to FIG. 4, it is desirable that the generally straight finger 52b is integrally connected to the torpedo 52a. For example, the slider 10 including the torpedo 52a and slider finger 52b may be formed by an injection molding process. The generally straight slider finger 52b, however, may be formed separately from the torpedo 52a.

5 The slider 10 with generally straight slider finger 52b is depicted in relation to the male profile 18 and the female profile 20 in FIG. 5. The generally straight slider finger 52b extends into and seats in an interior area 66 of the female profile 20. Specifically, the generally straight slider finger 52b extends through a female gap 68 formed between outer end extensions 70, 72 of the female profile 20. The generally straight slider finger 52b is shown in FIG. 5 as abutting a lower surface 74 of a groove 76 formed in the interior area 66. It is contemplated, however, that the generally straight slider finger 52b may not necessarily extend and abut the lower surface 74 of the groove 76 as long as the slider finger 52b assists in removing the material trapped in the interior area 66. For example, the generally straight slider finger 52b may extend to a location adjacent to or at an upper edge of the outer end extension 72 of FIG. 5 (see also FIG. 9). Preferably, the generally straight slider finger 52b assists in removing most, if not all, of the material, such as particles or powder, trapped in the female gap 68.

According to another embodiment that is depicted in FIG. 6, a slider 110 has an angled slider finger 152b. The slider 110 includes the angled slider finger 152b and a torpedo 152a.

20 The slider 110 with the angled slider finger 152b is shown with respect to a male profile 118 and a female profile 120 in FIG. 7. The angled slider finger 152b extends into and seats in an interior area 166 of the female profile 120. Specifically, the angled slider finger 152b extends through a female gap 168 formed between outer end extensions 170, 172. The angled slider finger 152b is shown in FIG. 7 as abutting a lower surface 174 of a groove 176 formed in the interior area 166 at an angle. It is contemplated, however, that the angled slider finger 152b may not necessarily extend and abut the lower surface 174 of the groove 176 as long as the angled slider finger 152b assists in removing the material trapped in the interior area 166. For example, the angled slider finger 152b may extend to a location adjacent to or at an upper edge of the outer end extension 172 of FIG. 7 (see also FIG. 9). Preferably, the angled slider finger 152b assists in removing

most, if not all, of the material, such as particles or powder, trapped in the female gap 168.

It is also contemplated that the generally straight slider finger 52b and the angled slider finger 152b may be sized and shaped differently than depicted in FIGs. 4-7. For example, in FIGs. 8-9, a slider 210 includes a torpedo 252a and a slider finger 252b that has been widened at one end to improve its strength while still assisting in removing material, such as particles or powder, from a female gap of the female profile 220. The slider finger 252b extends into an interior area 260 of the female profile 220. To reduce stress concentrations, edges 280 of the slider finger 252b of the slider 210 may be generally radiused as depicted in FIGs. 8 and 9. FIG. 9 depicts the relationship of the torpedo 252a and the slider finger 252b to the female profile 220 and male profile 218 in an open position.

Further examples of angled fingers are depicted in FIGs. 10 and 11. Referring to FIG. 10, a slider 300 is shown with a longer slider finger 302, as well as a male profile 304 and a female profile 306. The longer slider finger 302 extends and abuts a lower surface 308 of an interior area 310 of the female profile 306. Referring to FIG. 11, a slider 320 is shown with a wider slider finger 322, as well as a male profile 324 and a female profile 326. The wider slider finger 322 extends into an interior area 330 further than the angled slider 210 extends into the interior area 260 (FIG. 9).

According to one embodiment, a slider is adapted for use with a reclosable fastener for thermoplastic bags containing material. The reclosable fastener includes a first track and a second track. The first track includes a first profile, while the second track includes a second profile. The first and second profiles are releasably engageable to each other. At least one of the first and second profiles has an interior portion. The slider comprises a body that includes a top, a first side, a second side and a separation member on an underside of the top. The separation member is adapted to open and close the fastener and includes a slider finger that extends generally downwardly from the top. The slider finger extends into an interior portion of the first profile so as to assist in removing material trapped in the interior portion of the first profile when closing the reclosable fastener. The slider may be a unitary structure and may be an inverted

generally U-shaped member. The slider finger may be generally straight or angled, and the slider finger may abut a lower surface formed in the interior area of the profile.

Another embodiment is depicted in FIGs. 12-15 with slider 350. Referring first to FIGs. 12-13b, the slider 350 includes a torpedo 352a with a first angled slider finger 352b and a second angled slider finger 352c. It is desirable for the first angled slider finger 352b and the second angled slider finger 352c to be integrally connected to the torpedo 352a.

As shown in FIGs. 14 and 15, the first angled slider finger 352b extends into an interior area 358 of a first profile 360, while the second angled slider finger 352c extends into an interior area 378 of a second profile 380. The first angled slider finger 352b extends through a female gap 362 formed between two extensions 364, 366 of the first profile 360. The first angled slider finger 352b assists in removing the material trapped in the interior area 358. The first angled slider finger 352b preferably assists in removing most, if not all, of the material, such as particles or powder trapped in the female gap 362. The first angled slider finger 352b is not shown in FIG. 14 as abutting a lower surface 368 of the first profile 360. It is contemplated that the first angled slider finger 352b could extend to and abut the lower surface 368.

The second angled slider finger 352c assists in removing the material trapped in the interior area 378 of the second profile 380. The second angled slider finger 352c is shown as abutting portions of surfaces 382, 384 of the second profile 380. It is contemplated that the second angled slider finger 352c may abut one or none of the surfaces 382, 384.

It is contemplated that one slider finger with two distinct extensions may be able to extend into an interior area of the first and second profiles so as to assist in removing the trapped material.

The sliders 10, 110 and 210 may be formed from suitable polymeric materials such as, for example, nylon, polypropylene, polyethylene, polystyrene, copolymers of polyethylene and polypropylene, polycarbonates, polyesters, polyacetals, acrylic-butadiene-styrene copolymers or combinations thereof. The sliders 10, 110 and 210 of the present invention may be formed by injection molding.

### Elastomeric Profiles

According to another embodiment of the present invention, one or more of the profiles is designed to (a) expel material, such as particles or powder, that has been trapped, and/or (b) prevent or inhibit material from entering an interior area of the profile(s). One or more of the profiles uses a generally thin piece of elastic material to expel the material and/or prevent or inhibit material from entering an interior area of the profile(s).

According to this embodiment, a reclosable fastener is adapted for use with thermoplastic bags containing material. The reclosable fastener comprises a first track and a second track. The first track includes a first profile, while the second track includes a second profile. At least the first profile has an elastomeric portion attached thereto. The elastomeric portion is adapted to cover at least a portion of the first profile to prevent or inhibit the material from entering an interior area of the first profile and/or expel the material from the interior area of the first profile. The first and second profiles are releasably engageable to each other wherein the elastomeric portion is located between the first and second profiles during engagement thereto.

Referring to FIGs. 16-18, one embodiment of an elastomeric track of the present invention is depicted. Referring to FIG. 16, a fastener 400 includes a female track 402 and a male track 404. The female track 402 includes a female profile 406 and a female fin 408 and the male track 404 includes a male profile 416 and a male fin 418. The female profile 406 includes an elastomeric portion 410 and an interlocking profile 412. The elastomeric portion 410 is adapted to cover an opening to an interior cavity 422 as shown in FIGs. 16-17. The elastomeric portion 410 is attached or formed to an end 406a of the female profile 406 as depicted in, for example, FIG. 16. The elastomeric portion 410 may be attached or formed to the female profile 406 using a coextrusion process. It is contemplated that the elastomeric portion 410 may be attached to the female profile 406 using other methods known in the art.

Referring to FIG. 17, the elastomeric portion 410 is shown covering the opening to the interior cavity 422 and is sealed to the female fin 408. The seal between the elastomeric portion 410 and the female fin 408 may also include a seal to an opposing

body panel 414 as shown in FIG. 17. It is contemplated that the elastomeric portion 410 may be directed attached to an opposing body panel 414.

Referring to FIGs. 17 and 18, the elastomeric portion 410 is able to move or retract into the interior cavity 422 formed by the interlocking portion 412 when the female profile 406 is interlocked with the male profile 416. Thus, the elastomeric portion 410 must be of a sufficient elasticity to allow the male profile 416 to enter into the interior cavity 422 and interlock with the female profile 406. When the female profile 406 and the male profile 416 are not engaged, the elastomeric portion 410 pops open or snaps back so as to remove any unwanted material such as depicted in FIG. 17. This movement of the elastomeric portion 410 is depicted by comparing a first position of the elastomeric portion 410 (see FIG. 17) and a second position of the elastomeric portion 410 (see FIG. 18). The elastomeric portion 410 in the first position (FIG. 17) prevents or inhibits the material from entering the interior cavity 422 (including the female gap 413) of the female profile 406.

The elastomeric portion 410 may be placed in a first position (see FIG. 17) during the conversion of the bag (*i.e.*, when the track and bag are connected). The conversion of the bag may also include the addition of an optional slider and opposing end terminations. The elastomeric portion 410 fits into the interior cavity 422 of the female profile 406 under tension by the male profile 416. To better remove the trapped material, it is desirable that the elastomeric portion 410 extend through at least a female gap of the female profile 406.

The elastomeric portion 410 may be made of any suitable material that (a) moves during the process of interlocking the female and male profile 406, 416 and (b) retracts upon the disengaging of the female and male profiles 406, 416 to remove unwanted material from at least the female gap 413 of the interior cavity 422 of the female profile 406. Examples of materials that may be used in forming the elastomeric portion 410 include wrapping polymeric materials such as polyvinylidene chloride (*e.g.*, SARAN™ Wrap), rubber, rubberlike materials and alkenyl aromatic polymers (*e.g.*, polystyrene foam).

The thickness of the elastomeric portion 410 is typically thinner than the remainder of the female profile 406. The elastomeric portion 410 generally has a

thickness of from about 0.2 to about 10 mils and, more specifically, from about 0.5 to about 6 mils.

The interlocking portion 412 of the first profile 406, the second profile 416 and the fin portions 408, 418 may be independently made of polymeric resins such as polyolefinic resins. Nonlimiting examples of polyolefinic resins which may be used include low density polyethylenes, linear low density polyethylenes, high density polyethylenes (HDPE), medium density polyethylenes (MDPE), polypropylenes, plastomers, elastomers, ethylene vinyl acetates (EVA), ethyl methacrylates, polymethylpentene copolymers, polyisobutylenes, polyolefin ionomers, or combinations thereof. It is contemplated that other polyolefinic resins may be used. The preferred polyolefinic resins are low density polyethylenes and linear low density polyethylenes.

Referring to FIGs. 19-21, another embodiment using an elastomeric portion of the present invention is depicted. Referring to FIG. 19, a fastener 500 includes a female track 502 and a male track 504. The female track 502 includes a female profile 506 and a female fin 508 and the male track 504 includes a male profile 516 and a male fin 518. The female profile 506 includes an elastomeric portion 510 and an interlocking portion 512. The elastomeric portion 510 is adapted to cover an opening to an interior cavity 522 as shown in FIGs. 19-20. The elastomeric portion 510 is attached or formed in a different location of the female profile 506 than previously depicted in FIGs. 16-18 with respect to the elastomeric portion 410 and the female profile 406. Specifically, the elastomeric portion 510 is attached or formed to an end 506a of the female profile 506 where the end 506a forms a portion of female gap 513.

It is contemplated that the elastomeric portion may be attached to the interlocking portion at different locations than depicted in FIGs. 16-21. For example, the elastomeric portion may be attached to a portion of the interlocking portion 412 forming the interior cavity 422.

Referring to FIG. 20, the elastomeric portion 510 is shown covering the opening to the interior cavity 522 and is sealed to the female fin 508. The seal between the elastomeric portion 510 and the female fin 508 may also include a seal to an opposing body panel 514 as shown in FIG. 20. It is contemplated that the elastomeric portion 510 may be directed attached to an opposing body panel 514.

Referring to FIGs. 20 and 21, the elastomeric portion 510 is able to move or retract into the interior cavity 522 formed by the interlocking portion 512 when the female profile 506 is interlocked with the male profile 516. Thus, the elastomeric portion 510 must be of a sufficient elasticity to allow the male profile 516 to enter into the interior cavity 522 and interlock with the female profile 506. When the female profile 506 and the male profile 516 are not engaged, the elastomeric portion 510 pops open or snaps back so as to remove any unwanted material such as depicted in FIG. 20. This movement of the elastomeric portion 510 is depicted by comparing a first position of the elastomeric portion 510 (see FIG. 20) and a second position of the elastomeric portion 510 (see FIG. 21). The elastomeric portion 510 in the first position (FIG. 20) prevents or inhibits the material from entering the interior cavity 522 (including the female gap 513) of the female profile 506.

The elastomeric portion 510 may be placed in a first position (see FIG. 20) during the conversion of the bag (*i.e.*, when the track and bag are connected). The conversion of the bag may also include the addition of an optional slider and opposing end terminations. The elastomeric portion 510 fits into the interior cavity 522 of the female profile 506 under tension by the male profile 516. To better remove the trapped material, it is desirable that the elastomeric portion 510 extend through at least a female gap 513 of the female profile 506.

It is also contemplated that the elastomeric portion of the female profile may be used with different shaped female and/or male profiles, than those depicted in FIGs. 16-21.

The materials used to form the elastomeric portion 510 are the same as described above with respect to the elastomeric portion 410. Similarly, the materials used to form the interlocking portion 512 of the female profile 506, the male profile 516, and the fins 508, 518 are the same as described above to the interlocking portion 412, the male profile 416 and the fins 408, 418, respectively.

#### Fin Flap Fasteners

Referring to FIG. 22a, a fastener 600 includes a female track 602 and a male track 604. The female track 602 includes a female profile 606 and a female fin 608, and the male track 604 includes a male profile 616 and a male fin 618. The female fin 608 and the



male fin 618 include a female fin flap 610 and a male fin flap 620, respectively. The female fin 608 and the male fin 618 are attached to respective opposing body panels 612 and 622.

The female and male fin flaps 610, 620 are designed to prevent or inhibit material, such as particles or powder, from entering an interior area of the female profile 606 and/or male profile 616 during the pouring of the material from a pouch or bag. By reducing or eliminating material from entering the interior area of the female profile 606 and/or male profile 616, the likelihood of the entirely reclosing the profiles 606, 616 is increased.

The female fin flap 610 and the male fin flap 620 of FIG. 22a extend away from their respective fins 608, 618 in a generally upwardly and outwardly direction. Specifically, the female and male fin flaps 610, 620 extend generally toward the male and female profiles 606, 616. The female fin flap 610 and the male fin flap 620 extend away from the opposing body panels 612, 622. As shown in FIG. 22a, upper edges 610a, 620a of the male and female fin flaps 610, 620, respectively, are located near the respective profiles 606, 616 and also to each other so as to prevent or inhibit unwanted material from entering the interior areas of the profiles 606, 616.

The female fin flap 610 and the male fin flap 620 may be made of materials such as described above with respect to fins 408, 418. The female and male profiles 606, 616 may be made of materials such as discussed above with respect to male profile 416. Similarly, the female and male fins 608, 618 may be made of materials such as discussed above with respect to male and female fins 408, 418.

The female fin flap 610 and the male fin flap 620 may be integrally formed with the fins 608, 618, respectively. For example, the female fin 608 and the female fin flap 610 may be formed by profile extrusion. Similarly, the male fin 610 and the male fin flap 620 may be formed by profile extrusion or injection molding. Alternatively, the female fin 608 and the female fin flap 610 may be formed by coextrusion or other methods known in the art. Alternatively, the male fin 610 and the male fin flap 620 may be formed by coextrusion or other methods known in the art. For example, the female fin flap 610 and the male fin flap 620 may be attached to respective fins 608, 618 via an adhesive.

It is contemplated that the female and male fin flaps may be shaped differently and/or extend at different angles than depicted in FIG. 22a. The female and male fin flaps may extend from a different location on the respective fins than depicted in FIG. 22a. The fin flaps are not limited to the specific female and male profiles 606, 616 depicted in FIG. 22a.

For example, in FIG. 22b, a fastener 650 includes the female track 602 and the male track 604 and is shown in a non-interlocked position. The female track 602 includes the female profile 606 and the female fin 608, and the male track 604 includes the male profile 616 and the male fin 618. The female fin 608 and the male fin 618 include a female fin flap 660 and a male fin flap 670, respectively. The female fin 606 and the male fin 616 are attached to the respective opposing body panels 612 and 622. The female fin flap 660 has an end 660a that extends near to or above an interior cavity of the female profile 606. Similarly, the male fin flap 670 has an end 670a that extends near to or above an interlocking portion of the male profile 616.

It is also contemplated that the fin flap may be located on only one of the profiles. For example, in FIG. 22c, fastener 600a includes a female track 602a that includes the female profile 606 and the female fin 608, but does not include a female fin flap. The male track 604 of FIG. 22c includes the male fin flap 620 that prevents or inhibits material from entering the interior area of the male track 604 such as area 626. Alternatively, the fastener may include a female track that includes a female fin flap such as female track 602 of FIG. 22a and a male track that does not include a male fin flap.

#### Deflection Shield on Profile(s)

Referring to FIG. 23, a female profile 700 is depicted that includes an extension portion or ear 702, a generally c-shaped section 704 and a generally thin-walled deflection shield 706. The thin-walled deflection shield 706 extends generally perpendicularly between outer ends 708, 710 of the generally c-shaped section 704. The ear 702 extends generally upwardly and outwardly from the generally c-shaped section 704 as depicted in FIG. 23.

The c-shaped section 704 includes a first portion 712 and two extensions 714, 716. The two extensions 714, 716 are generally perpendicular to and extend from the

first portion 712. The two extensions 714, 716 are spaced apart from each other so as to form an interior area or cavity 718.

The thin-walled deflection shield 706 is designed to have at least a portion thereof (e.g., a seam portion) that enables a male profile to enter the interior area 718. The interior area 718 is adapted to receive a male profile (e.g., male profile 730 in FIG. 24) that interlocks with the female profile 700. The seam portion 706a of the deflection shield 706 is thinner than the remainder of the deflection shield 706 and is adapted to be broken, ruptured or slit by the male profile. The seam portion 706a is a stress point on the deflection shield 706 that is designed to break, rupture or slit before the remainder of the deflection shield 706. The seam portion 706a of the deflection shield 706 is preferably broken, ruptured or slit by the male profile during the closing of the track.

The interlocking relationship between the female profile 700 and the male profile 730 is depicted in FIG. 24. The male profile 730 enters the interior area 718 through the deflection shield 706 and, more specifically, the seam portion 706a.

Upon the disengagement of the female profile 700 and the male profile 730 (see FIG. 25), the deflection shield 706 is split into a first deflection shield 706b and a second deflection shield 706c. The first and second deflection shields 706b, 706c assist in preventing or inhibiting material, such as particles or powder, from entering the interior area 718 of the female profile 700. For example, the deflection shields 706b, 706c assist in preventing or inhibiting material, such as particles or powder, from entering a female gap 722. The female gap 722 of the female profile 700 is formed by the breaking, rupturing or slitting of the seam portion 706a.

The deflection shield 706 may be made from polymeric materials such as polyolefins, including polyethylenes, polypropylenes and combinations thereof. More specifically, the deflection shield 706 may be made of the materials discussed above in the fins 408, 418. The remainder of the female profile 700 (the ear 702 and the generally c-shaped section 704) may be formed by the same material as the deflection shield 706. It is contemplated, however, that the remainder of the female profile 700 may be formed from different materials than the deflection shield 706.

It is desirable that the deflection shields 706b, 706c have some flexibility to allow the male profile 730 to enter the female profile 700. The deflection shields 706b, 706c

may have flexibility due to the thickness of the shields 706b, 706c and/or the materials used in forming the deflection shields 706b, 706c. This allows the first and second deflection shields 706b, 706c to be lengthened which assists in preventing or inhibiting more material from entering into or through the female gap 722. If the deflection shields 706b, 706c are not flexible, then the seam portion 706a must be sized to correspond with an interlocking portion of the male profile 730 that enters the interior area 718.

The first and second deflection shields 706b, 706c generally have a thickness of from about 0.5 to about 10 mils and more specifically, from about 2 to about 5 mils. The seam portion 706a is preferably thinner than the deflection shields 706b, 706c. The seam portion 706a generally has a thickness of from about 0.2 to about 8 mils and, more specifically, from about 1 to about 4 mils.

The female profile 700 with the deflection shield 706 may be formed by an extrusion process. The female profile 700 may be integrally formed. An air injection process is contemplated that will enhance the cooling time of the materials, especially the surfaces forming the interior area 718.

Alternatively, a female profile may comprise the first and second deflection shields 706b, 706c without the seam portion 706a. In other words, the female profile may initially have a small slit opening or gap (e.g., the female gap 722 of FIG. 25) formed between first and second deflection shields 706b, 706c. This of course would eliminate the need of a male profile from breaking, rupturing or slitting a portion of the thin-walled deflection shield 706.

According to another embodiment depicted to FIGs. 26 and 27, a female profile 750 includes an extension portion or ear 752, a generally c-shaped section 754 and a gasket portion 756. The gasket portion 756 is located in an interior area or cavity 758 that is defined by an interior surface of the generally c-shaped section 754.

The gasket portion 756 assists in preventing or inhibiting materials, such as particles or powders, from entering the interior area 758 by deflecting such materials. The gasket portion 756 prevents or inhibits such material from entering the interior area 758 when the female profile 750 and male profile 770 (see FIG. 27) are not interlocked. The gasket portion also may expel material from the interior area 758 upon the disengagement of the female profile 750 and the male profile 770. The gasket portion

756 is shown as extending to or near a female gap 760. The female gap 760 is formed between ends 754a, 756b of the generally c-shaped section 754. When the female profile 750 and the male profile 770 are in an interlocking position (see FIG. 27), the gasket portion 756 is pushed back away from the female gap 760. After the female profile 750 and the male profile 770 are disengaged, the gasket portion 756 returns to or near its initial position depicted in FIG. 26.

The gasket portion 756 should be made of a generally resilient material so as to allow the gasket portion 756 to (a) compress in response to the process of interlocking the female profile 750 and the male profile 770 and (b) return to its initial position of FIG. 26 when the female profile 750 and the male profile 770 are not interlocked. The gasket portion 756 may be made of materials such as described above with respect to the male profile 416. The gasket portion 756 may have resiliency due to the thickness thereof. The remainder of the female profile 750 (ear 752 and generally c-shaped section 754) may be made of the same materials such as described above with male profile 416. It is contemplated that the remainder of the female profile 750 may be made of different materials than the gasket portion 756.

The female profile 750, including the gasket portion 756, may be formed from an extrusion process. It is contemplated that the female profile 750 with the gasket portion 756 may be formed by other methods known in the art, such as an injection molding process.

#### Track-In Track

According to yet another embodiment, a track-in-track feature is designed to prevent or inhibit materials, such as particles or powders, from entering an interior area of the female and male profiles. The track-in-track embodiment includes first male and female profiles being fit or engaged with second female and male profiles, respectively.

According to this embodiment, a reclosable fastener is adapted for use with thermoplastic bags having an interior space adapted to receive material. The reclosable fastener comprises a first male track, a second male track, a first female track, a second female track and a slider. The first and second male track includes a respective first and second male profile. The first and second female track includes a respective first and second female profile. The second male and female profiles are attached to the slider and

when the slider is moved to an open position, the second male and female profiles engage with a respective first female and first male profiles so as to prevent or inhibit material from entering the interior first female and male profiles. When the slider is moved to a closed position, the second male and female profiles disengage with a respective first female and first male profiles.

Referring to FIG. 28, a polymeric bag 800 is depicted with a fastener 812. The fastener 812 comprises a slider 814, a first female profile 816, a first male profile 818, a second female profile 820 and a second male profile 822. The second female profile 820 and the second male profile 822 are attached to the slider 814. The profiles 820, 822 may be molded, for example, to the slider 814.

As the slider 814 is moved to an open position, the second female and male profiles 820, 822 slide forward and engage with respective first male profile 818 and first female profile 816. For example, a cross sectional of the profiles 816, 818, 820 and 822 is depicted in FIG. 29 where the cross sectional is taken across the profiles where the profiles 816, 818 are not engaged to each other (*i.e.*, an open position). The profiles 816, 822 and 818, 820 in FIG. 29, however, are respectively interlocked to each other. The interlocked profiles 816, 822 and 818, 820 prevent or inhibit materials, such as particles or powders, from entering the tracks or profiles.

As depicted in FIG. 29, the profile 816 has a fin portion 824 extending generally downwardly therefrom. The fin portion 824 is attached to body panel 825. Similarly, the profile 818 has a fin portion 826 extending generally downwardly therefrom. The fin portion 826 is attached to body panel 827. When the profiles 816, 822 and 818, 820 are respectively engaged, material may still be poured from an area 828 between the profiles 820 and 822 as shown in FIG. 29. The area 828 may be increased by moving the engaged profiles 816, 822 and 818, 820 further apart from each other.

When the bag 800 is in a closed position, the first profiles 816, 818 are interlocked with each other and the second profiles 820, 822 extend into the bag region. The second profiles 820, 822 may extend in a generally downwardly direction into an interior of the bag 800 such as depicted in FIG. 28. The second profiles 820, 822 may extend into the interior of the bag 800 in a coiled manner such as depicted in FIG. 30. The second profiles 820, 822 may be formed with slip or antiblock additives so as to prevent or inhibit

friction with a side 830 of the bag (see FIGs. 28 and 30) by improving the slip characteristics of the second profiles 820, 822. Contemplated slip additives include silicas, talcs, diatomaceous earth, silicates, lubricants, etc.

The first profiles 816, 818 and the second profiles 820, 822 may be independently  
5 formed from materials such as made of polymeric resins such as polyolefinic resins. Nonlimiting examples of polyolefinic resins which may be used include low density polyethylenes (LDPE), linear low density polyethylenes (LLDPE), high density polyethylenes (HDPE), medium density polyethylenes (MDPE), polypropylenes (PP),  
plastomers, elastomers, ethylene vinyl acetates (EVA), ethyl methacrylates,  
10 polymethylpentene copolymers, polyisobutylenes, polyolefin ionomers, or combinations thereof. It is contemplated that other polyolefinic resins may be used. The preferred polyolefinic resins are low density polyethylenes and linear low density polyethylenes.

While the present invention has been described with reference to one or more  
particular embodiments, those skilled in the art will recognize that many changes may be  
15 made thereto without departing from the spirit and scope of the present invention. Each of these embodiments and obvious variations thereof is contemplated as falling within the spirit and scope of the claimed invention, which is set forth in the following claims.

The embodiments of the invention in which an exclusive property or privilege is claimed are defined as follows:

1. A reclosable fastener for use with bags having an interior space adapted to receive material, the reclosable fastener comprising:

a first track comprising a first profile, first fin portion and a first fin flap, the first fin portion extending generally downwardly from the first profile, the first fin flap being attached to the first fin and extending upwardly and outwardly toward the interior of the bag so as to prevent or inhibit material from entering at least one interior area of the first profile and a second profile; and

a second track comprising the second profile, a second fin portion and a second fin flap, the first and second profiles being releasably engageable to each other, the second fin portion extending generally downwardly from the second profile, the second fin flap being attached to the second fin portion and extending upwardly and outwardly toward the interior space of the bag so as to prevent or inhibit material from entering at least one interior area of the first and second profiles; and

a slider configured to operate on the first and second tracks, the slider being slidable along the first and second tracks from an open position to a closed position, in which the first and second profiles are disengaged when the slider is in the open position and engaged when the slider is in the closed position.

2. The fastener of claim 1, wherein the first fin flap is integrally formed with first fin portion and the second fin flap is integrally formed with second fin portion.

3. The fastener of claim 1 or 2, wherein an upper edge of the first fin flap is in close proximity to the first profile.

4. The fastener of claim 3, wherein an upper edge of the second fin flap is in close proximity to the second profile.

5. The fastener of any one of claims 1 to 4, wherein the first fin flap extends upwardly past the interior area of the first profile.



6. The fastener of any one of claims 1 to 4, wherein the first fin flap and the second fin flap extend upwardly and outwardly toward the interior space of the bag such that during the engagement of the first and second profiles, the first fin flap and the second fin flap are trapped between the first and second profiles.
7. The fastener of any one of claims 1 to 4, wherein the first fin flap extends to and abuts a lower surface of the first profile, the second fin flap extends to and abuts a lower surface of the first profile, and the first and second fin flaps abut each other.
8. The fastener of any one of claims 1 to 4, wherein the first fin flap and the second fin flap extend upwardly and outwardly toward the interior space of the bag such that during the engagement of the first and second profiles, the first fin flap and the second fin flap are located beneath the first and second profiles in a non-interlocked position.
9. The fastener of any one of claims 1 to 4, wherein the first fin flap, first fin, second fin flap and second fin each comprise material independently comprising low density polyethylenes, linear low density polyethylenes, high density polyethylenes (HDPE), medium density polyethylenes (MDPE), polypropylenes, plastomers, elastomers, ethylene vinyl acetates (EVA), ethyl methacrylates, polymethylpentene copolymers, polyisobutylenes, polyolefin ionomers, or combinations thereof.
10. The fastener of any one of claims 1 to 4, wherein the first fin flap, first fin, second fin flap and second fin comprise the same material comprising low density polyethylenes, linear low density polyethylenes, high density polyethylenes (HDPE), medium density polyethylenes (MDPE), polypropylenes, plastomers, elastomers, ethylene vinyl acetates (EVA), ethyl methacrylates, polymethylpentene copolymers, polyisobutylenes, polyolefin ionomers, or combinations thereof.
11. The fastener of any one of claims 1 to 10, wherein the first profile and the second profile are formed by profile extrusion.
12. The fastener of any one of claims 1 to 10, wherein the first profile and the second profile are formed by injection molding.

13. A reclosable fastener for use with bags having an interior space adapted to receive material, the reclosable fastener comprising:

a first track comprising a first profile, and first fin portion, the first fin portion extending generally downwardly from the first profile;

a second track comprising a second profile, a second fin portion and a first fin flap, the first and second profiles being releasably engageable to each other, the second fin portion extending generally downwardly from the second profile, the first fin flap being attached to the second fin portion and extending upwardly and outwardly toward the interior space of the bag so as to prevent or inhibit material from entering at least one interior area of the first and second profiles; and

a slider configured to operate on the first and second tracks, the slider being slidable along the first and second tracks from an open position to a closed position, in which the first and second profiles are disengaged when the slider is in the open position and engaged when the slider is in the closed position.

14. The fastener of claim 13, wherein the second profile is a male profile.

15. The fastener of claim 13 or 14, wherein the first fin flap is integrally formed with second fin portion.

16. The fastener of any one of claims 13 to 15, wherein an upper edge of the first fin flap is in close proximity to the second profile.

17. The fastener of any one of claims 13 to 16, wherein the first fin flap extends upwardly and outwardly toward the interior space of the bag such that during the engagement of the first and second profiles, the first fin flap is trapped between the first and second profiles.

18. The fastener of any one of claims 13 to 16, wherein the first fin flap extends to and abuts a lower surface of the second profile.

19. The fastener of any one of claims 13 to 18, wherein the first fin flap, first fin, and second fin each comprise material independently comprising low density polyethylenes,

linear low density polyethylenes, high density polyethylenes (HDPE), medium density polyethylenes (MDPE), polypropylenes, plastomers, elastomers, ethylene vinyl acetates (EVA), ethyl methacrylates, polymethylpentene copolymers, polyisobutylenes, polyolefin ionomers, or combinations thereof.

20. The fastener of any one of claims 13 to 19, wherein the first profile and the second profile are formed by profile extrusion.

21. The fastener of any one of claims 13 to 19, wherein the first profile and the second profile are formed by injection molding.

22. A reclosable fastener for use with bags having an interior space adapted to receive material, the reclosable fastener comprising:

a first track comprising a first profile having an interior area, the first profile having a generally thin walled deflection shield that prevents or inhibits material from entering the interior area of the first profile; and

a second track comprising a second profile, the first and second profiles being releasably engageable to each other by having a portion of the second profile enter an interior area of the first profile;

wherein a portion of the generally thin walled deflection shield is adapted to break, rupture or slit in response to a portion of the second profile entering the interior area of the first profile.

23. The fastener of claim 22, wherein the generally thin walled deflection shield is formed by a seam portion.

24. The fastener of claim 23, wherein the seam portion is thinner than the remainder of the generally thin wall deflection shield.

25. The fastener of any one of claims 22 to 24, wherein the first profile forms a general c-shape that includes at least two extensions having respective ends, the generally thin walled deflection shield attached to and extending between the respective ends.

26. The fastener of claim 25, wherein the generally thin walled deflection shield is perpendicular to the respective ends.
27. The fastener of any one of claims 22 to 26, wherein the generally thin walled deflection shield upon breaking, rupturing or slitting in response to a portion of the second profile entering the interior area of the first profile forms two deflection shields.
28. The fastener of any one of claims 22 to 27, wherein the first profile is integrally formed.
29. The fastener of any one of claims 22 to 28, wherein the generally thin wall deflection shield is flexible.
30. The fastener of any one of claims 22 to 29, wherein the generally thin wall deflection shield has a thickness of from about 0.5 to about 10 mils.
31. The fastener of any one of claims 22 to 29, wherein the generally thin walled deflection shield is formed by a seam portion, the seam portion has a thickness of from about 0.2 to about 8 mils.
32. The fastener of claim 31, wherein the seam portion has a thickness of from about 1 to about 4 mils.
33. The fastener of any one of claims 22 to 32, wherein the generally thin wall deflection shield comprises at least one polyolefin.
34. The fastener of claim 33, wherein the generally thin wall deflection shield comprises polyethylene, polypropylene, or combinations thereof.
35. The fastener of any one of claims 22 to 34, wherein the first profile is formed by an extrusion process.

36. The fastener of any one of claims 22 to 34, wherein the first profile is formed by an injection-molded process.

37. A reclosable fastener for use with bags having an interior space adapted to receive material, the reclosable fastener comprising:

a first track comprising a first profile, the first profile being a general c-shape and further including two generally thin walled deflection shields, the general c-shape being formed from two extensions spaced apart and attached to a first portion, the two extensions having respective outer ends each spaced from the first portion, each of the two generally thin walled deflection shields being attached near a respective one of the outer ends of the two extensions so as to prevent or inhibit material from entering the interior area of the first profile;

a second track comprising a second profile, the first and second profiles being releasably engageable to each other; and

a slider configured to operate on the first and second tracks, the slider being slidable along the first and second tracks from an open position to a closed position, in which the first and second profiles are disengaged when the slider is in the open position and engaged when the slider is in the closed position;

wherein the generally thin walled deflection shields are spaced slightly apart so as to allow a portion of the second profile to enter into the interior area formed by the general c-shape section.

38. The fastener of claim 37, wherein each of the generally thin walled deflection shields are perpendicular to a respective end thereof.

39. The fastener of claim 37 or 38, wherein the first profile is integrally formed.

40. The fastener of any one of claims 37 to 39, wherein the generally thin wall deflection shields are flexible.

41. The fastener of any one of claims 37 to 40, wherein the generally thin walled deflection shields have a thickness of from about 0.2 to about 10 mils.

42. The fastener of any one of claims 37 to 41, wherein the generally thin wall deflection shields comprise at least one polyolefin.
43. The fastener of claim 42, wherein the generally thin wall deflection shields comprise polyethylene, polypropylene, or combinations thereof.
44. The fastener of any one of claims 37 to 43, wherein the first profile is formed by an extrusion process.
45. The fastener of any one of claims 37 to 44, wherein the first profile is formed by an injection-molded process.
46. A reclosable fastener for use with bags having an interior space adapted to receive material, the reclosable fastener comprising:  
a first track comprising a first profile, the first profile including a resilient gasket formed in an interior area thereof, the gasket extending near an opening to the interior area so as to prevent or inhibit material from entering the interior area of the first profile and/or expel material from the interior area of the first profile; and  
a second track comprising a second profile, the first and second profiles being releasably engageable to each other;  
wherein the gasket is compressed from an initial position upon engagement of the first and second profiles, and substantially returns to the initial position when the first and second profiles are disengaged.
47. The fastener of claim 46, wherein the first profile is a generally c-shape.
48. The fastener of claim 46 or 47, wherein the gasket returns to its initial position upon disengagement of the first and second profiles.
49. The fastener of any one of claims 46 to 48, wherein the gasket comprises low density polyethylenes, linear low density polyethylenes, high density polyethylenes (HDPE), medium density polyethylenes (MDPE), polypropylenes, plastomers,

elastomers, ethylene vinyl acetates (EVA), ethyl methacrylates, polymethylpentene copolymers, polyisobutylenes, polyolefin ionomers, or combinations thereof.

50. The fastener of any one of claims 46 to 50, wherein the first profile is formed by an extrusion process.

51. The fastener of any one of claims 46 to 50, wherein the first profile is formed by an injection-molded process.

52. The fastener of any one of claims 1 to 12, wherein the slider straddles the first and second tracks and comprises a separation member extending between the first and second tracks, the separation member being adapted to open and close the first and second tracks.

53. The fastener of any one of claims 13 to 21, wherein the slider straddles the first and second tracks and comprises a separation member extending between the first and second tracks, the separation member being adapted to open and close the first and second tracks.

54. A reclosable fastener for use with bags having an interior space adapted to receive material, the reclosable fastener comprising:

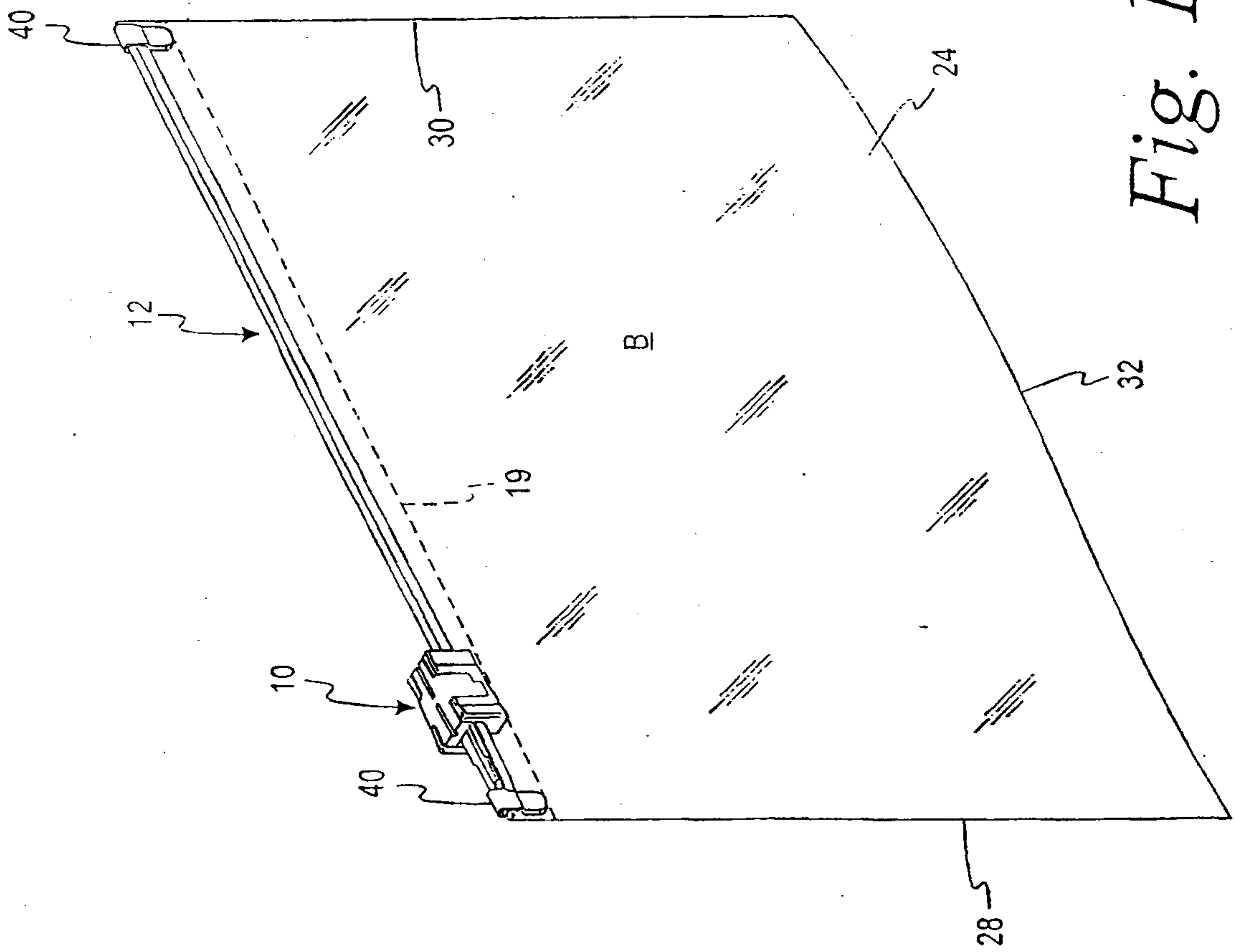
a first track comprising a first profile, first fin portion and a first fin flap, the first fin portion extending generally downwardly from the first profile, the first fin flap being attached to the first fin and extending upwardly and outwardly toward the interior of the bag so as to prevent or inhibit material from entering at least one interior area of the first and second profiles; and

a second track comprising a second profile, a second fin portion and a second fin flap, the first and second profiles being releasably engageable to each other, the second fin portion extending generally downwardly from the second profile, the second fin flap being attached to the second fin portion and extending upwardly and outwardly toward the interior space of the bag so as to prevent or inhibit material from entering at least one interior area of the first and second profiles;

wherein the first fin flap and the second fin flap extend upwardly and outwardly toward the interior space of the bag such that during the engagement of the first and second

profiles, the first fin flap and the second fin flap are located entirely beneath the first and second profiles in a non-interlocked position.





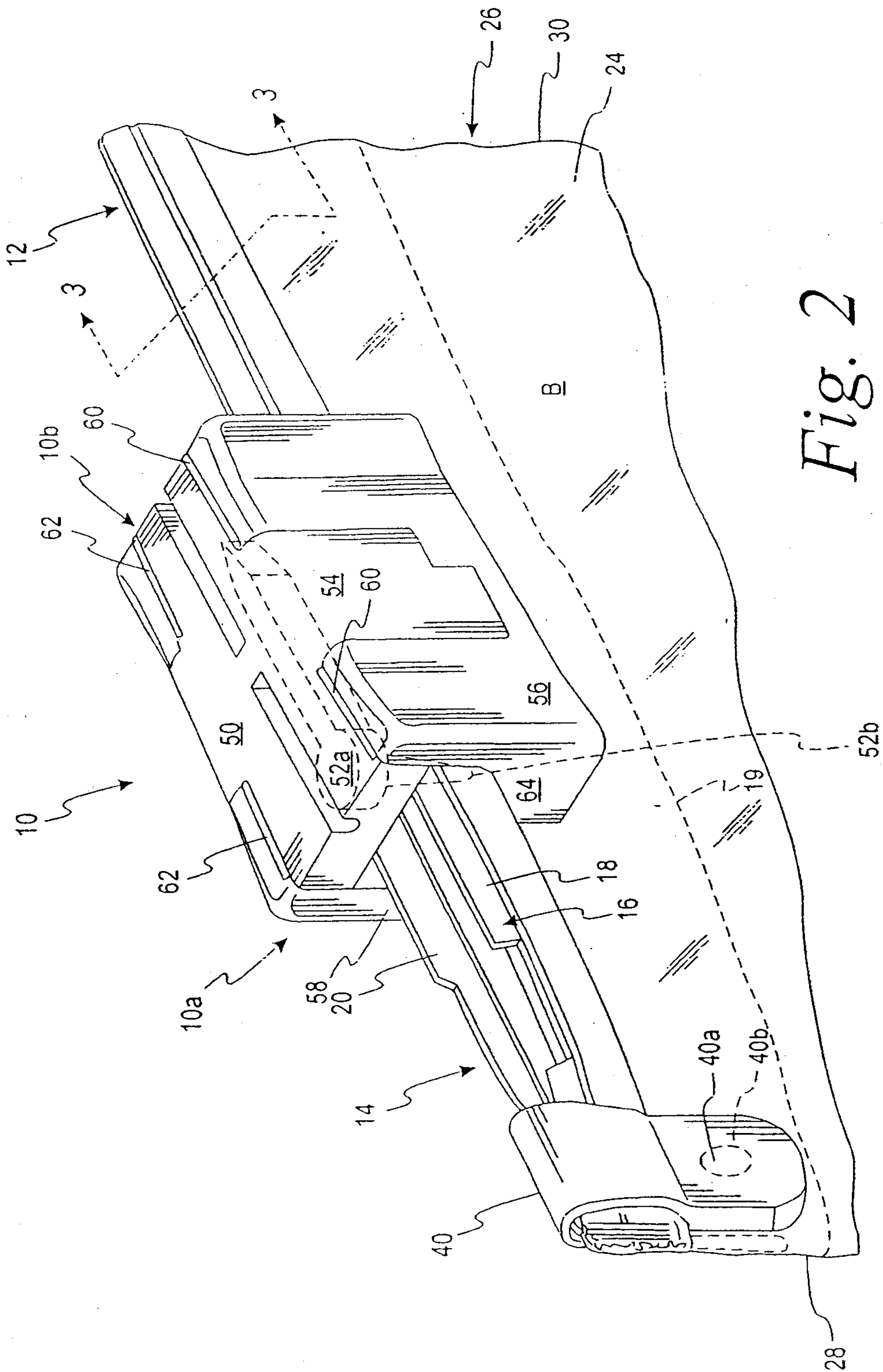


Fig. 2

3/18

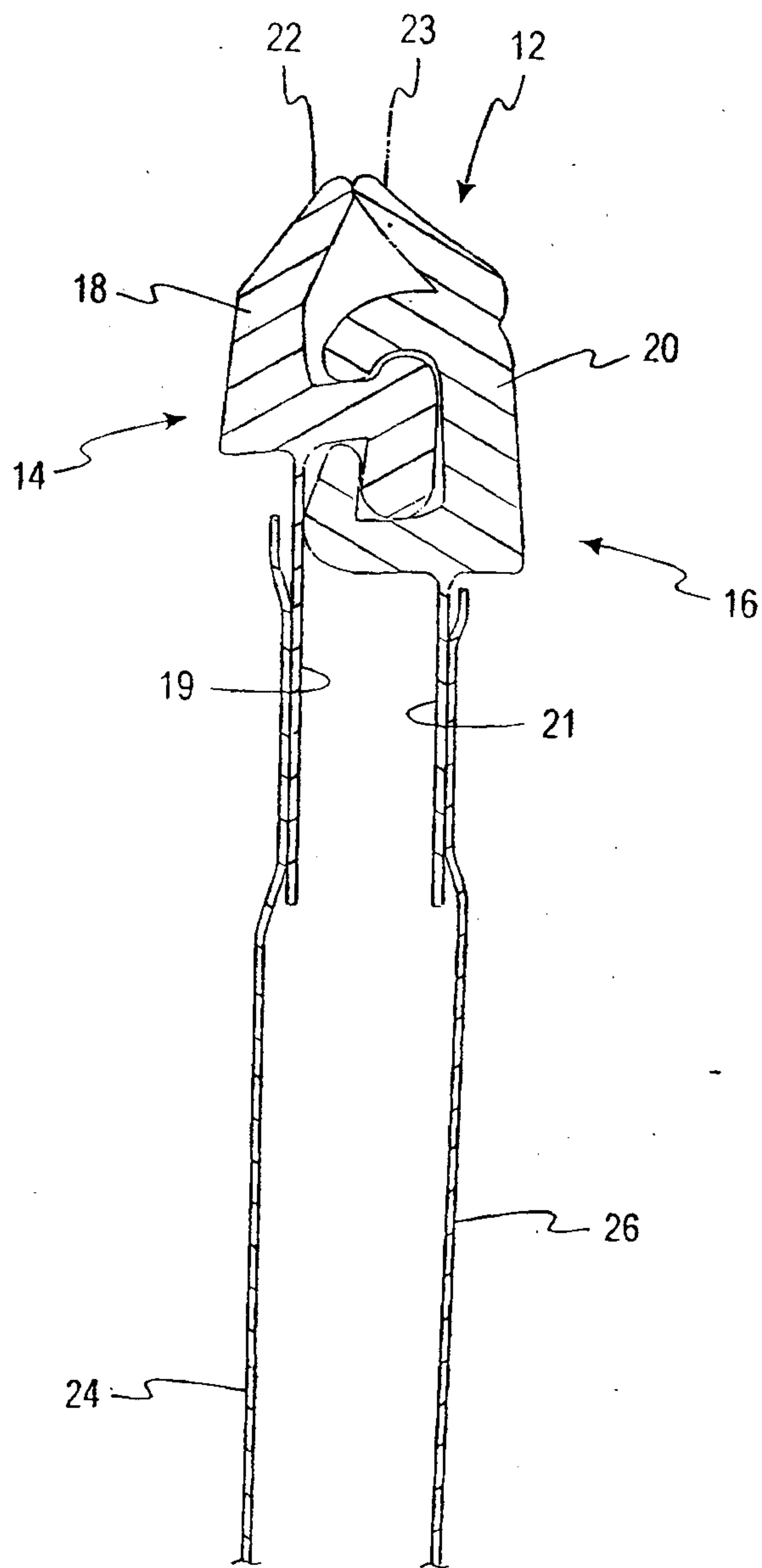


Fig. 3

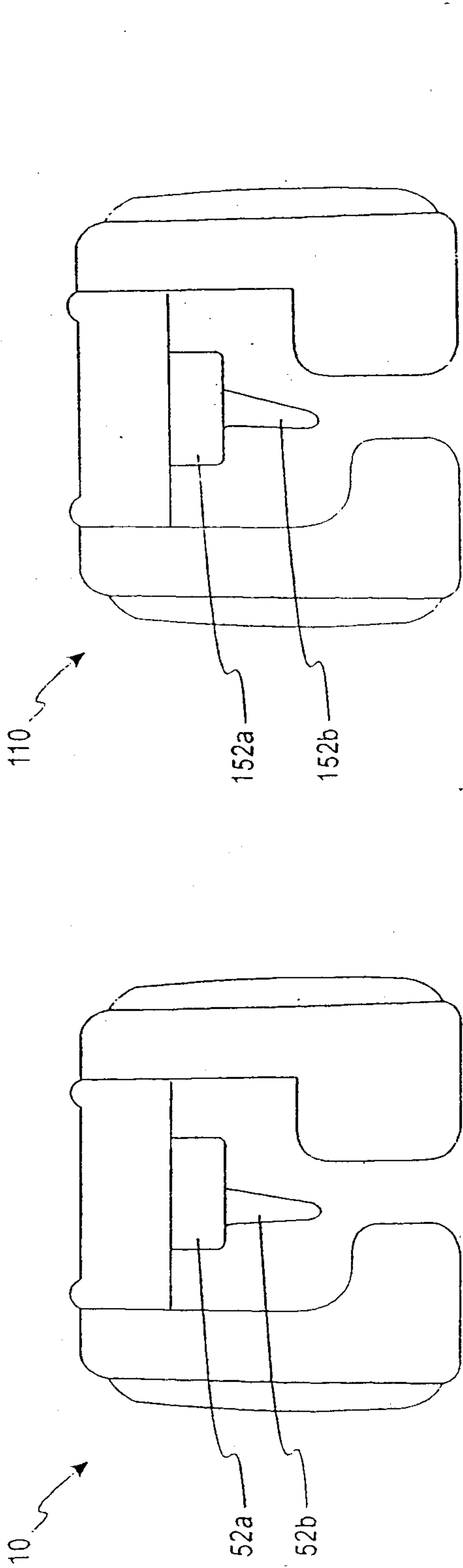


Fig. 6

Fig. 4

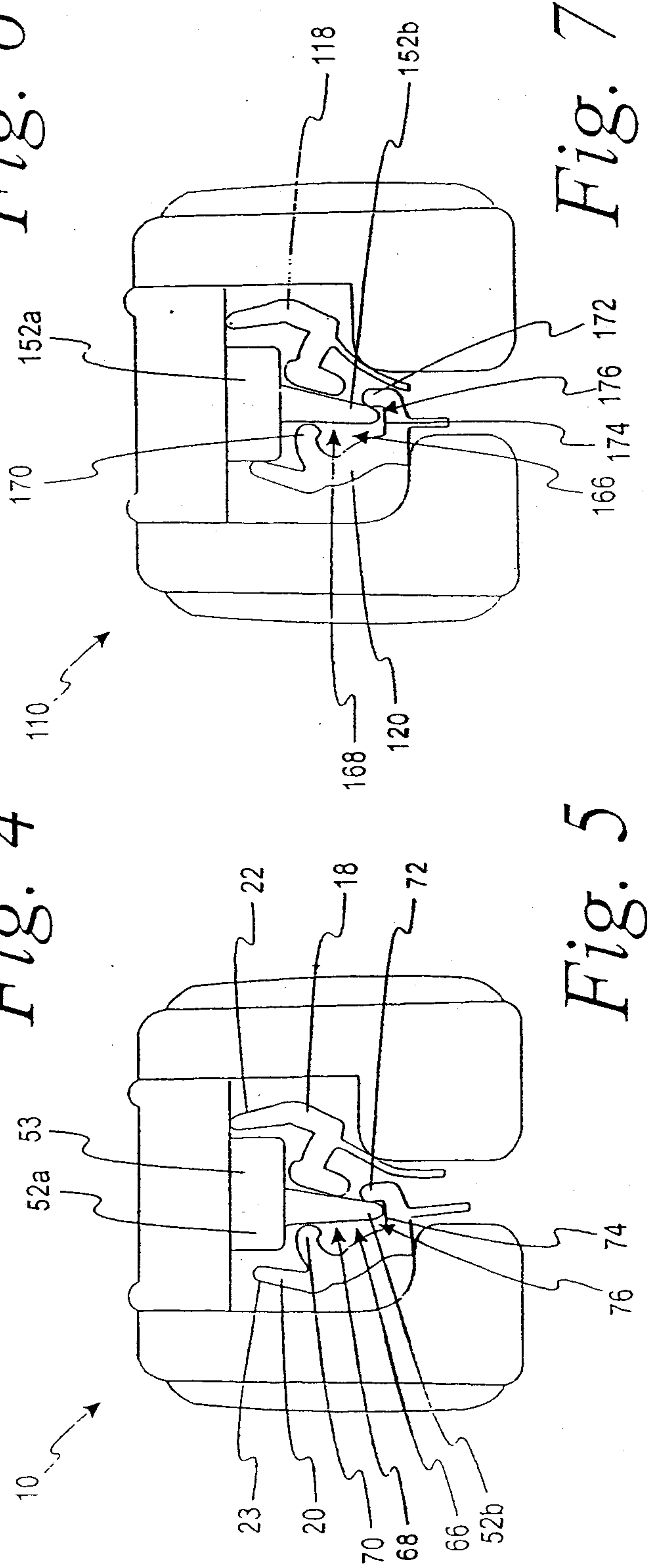
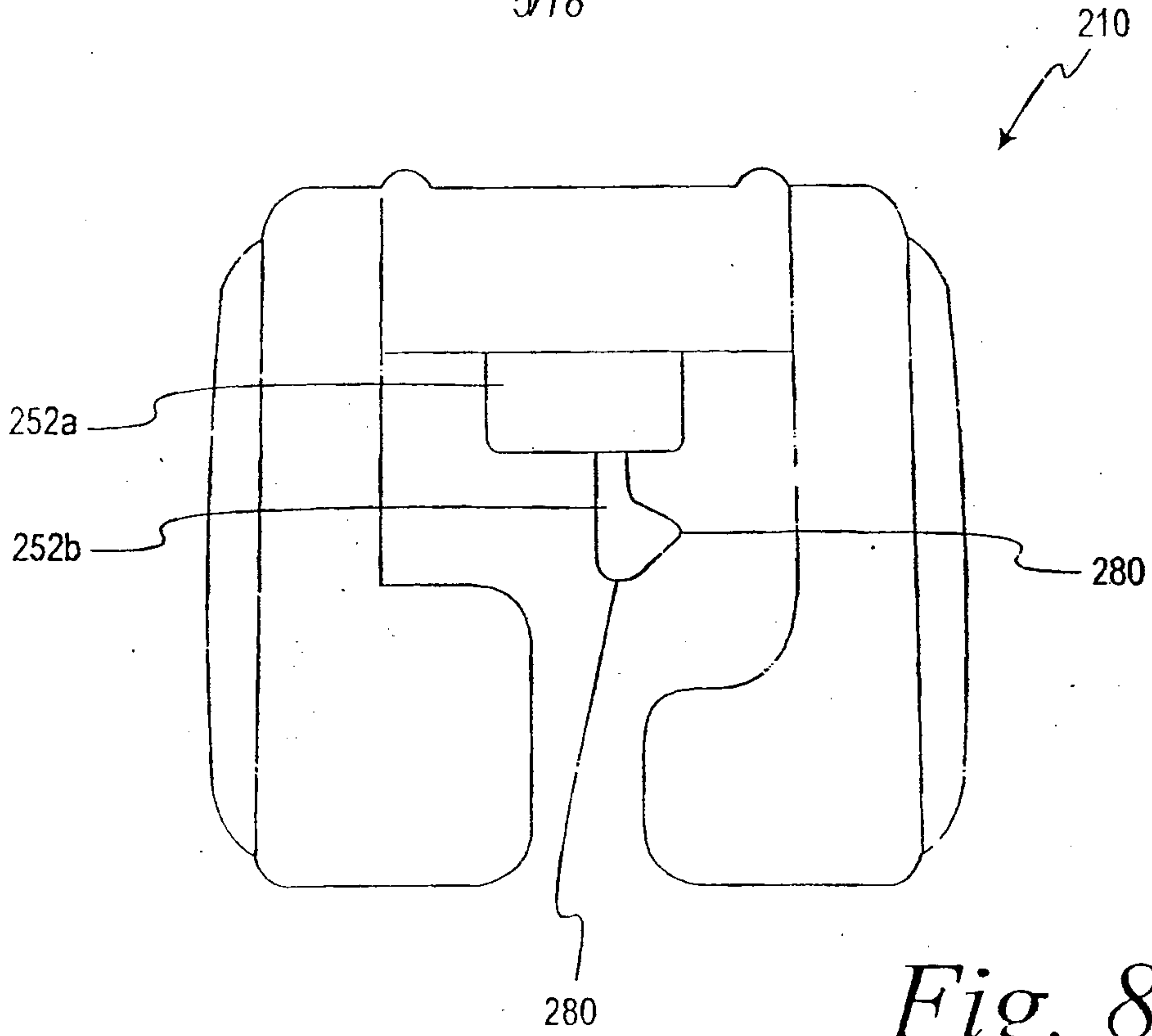


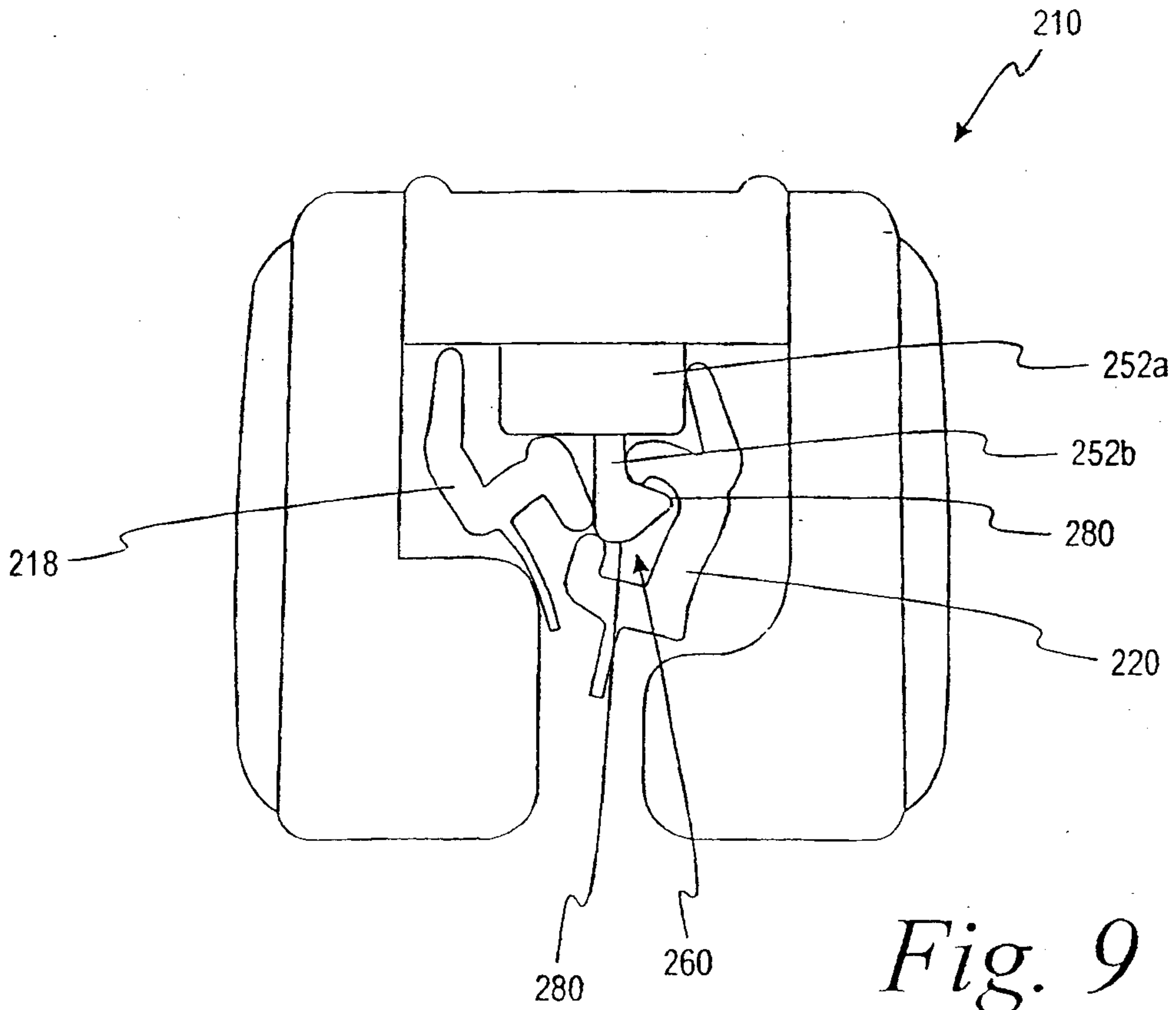
Fig. 7

Fig. 5

5/18



*Fig. 8*



*Fig. 9*

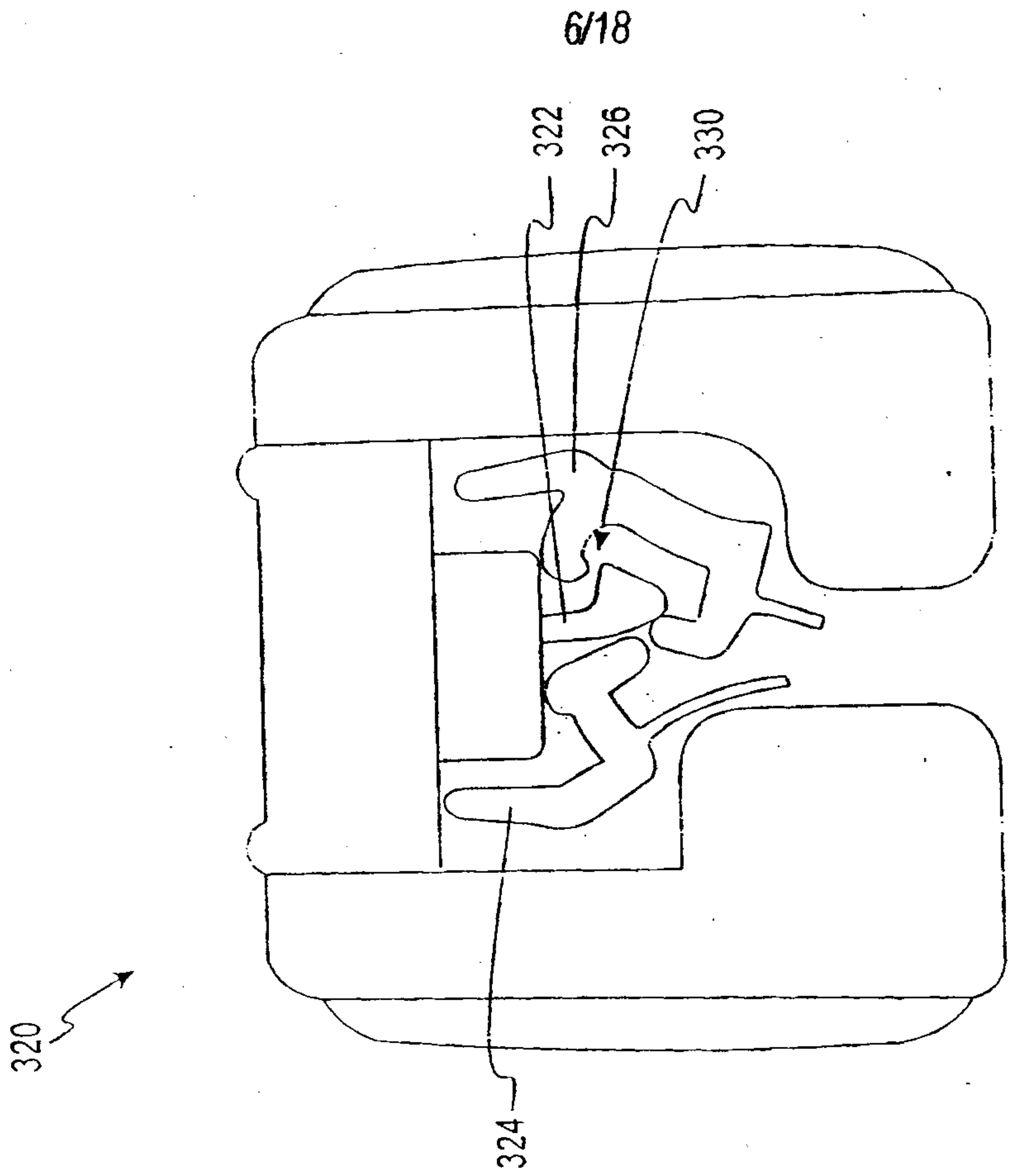


Fig. 10

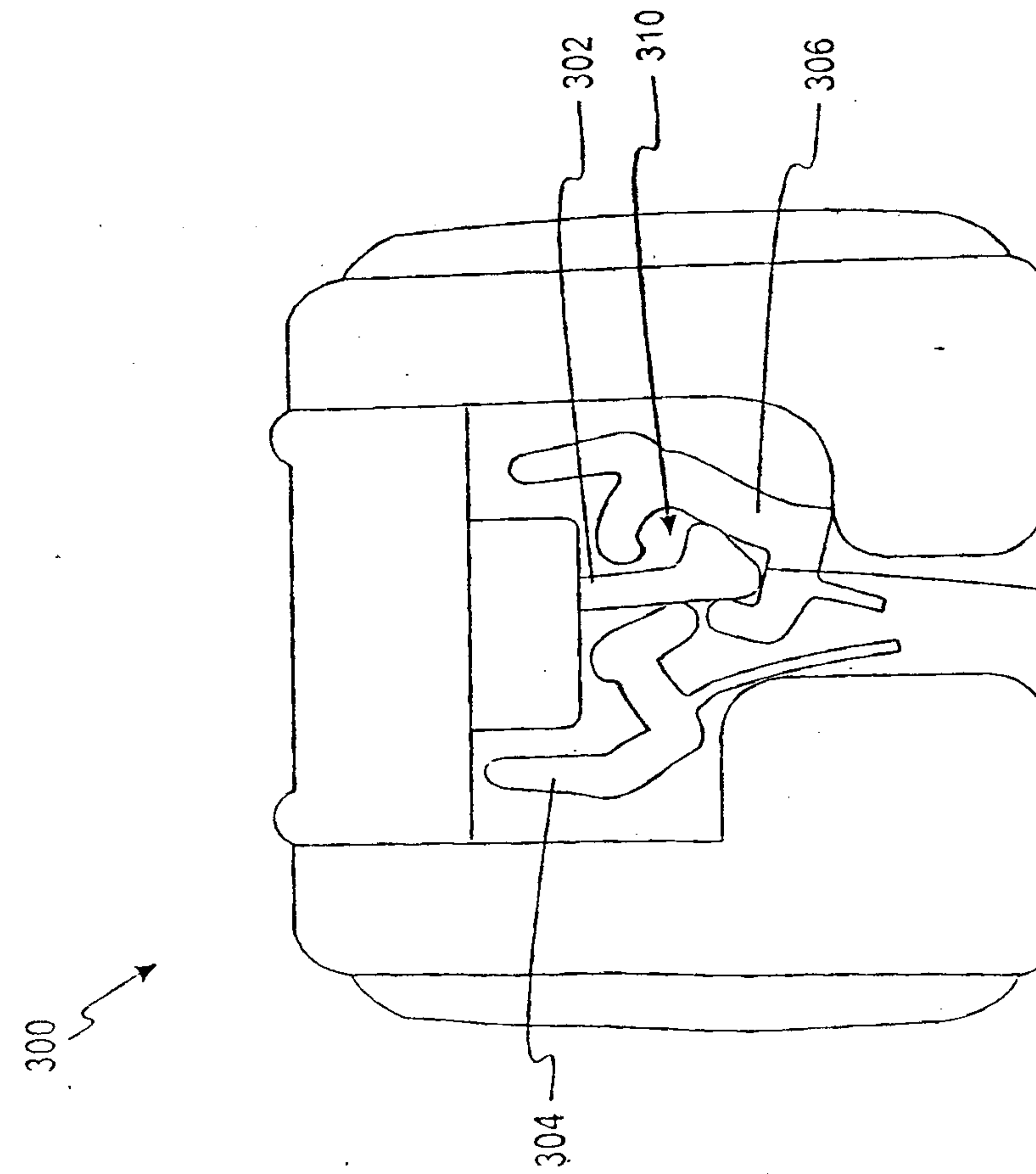
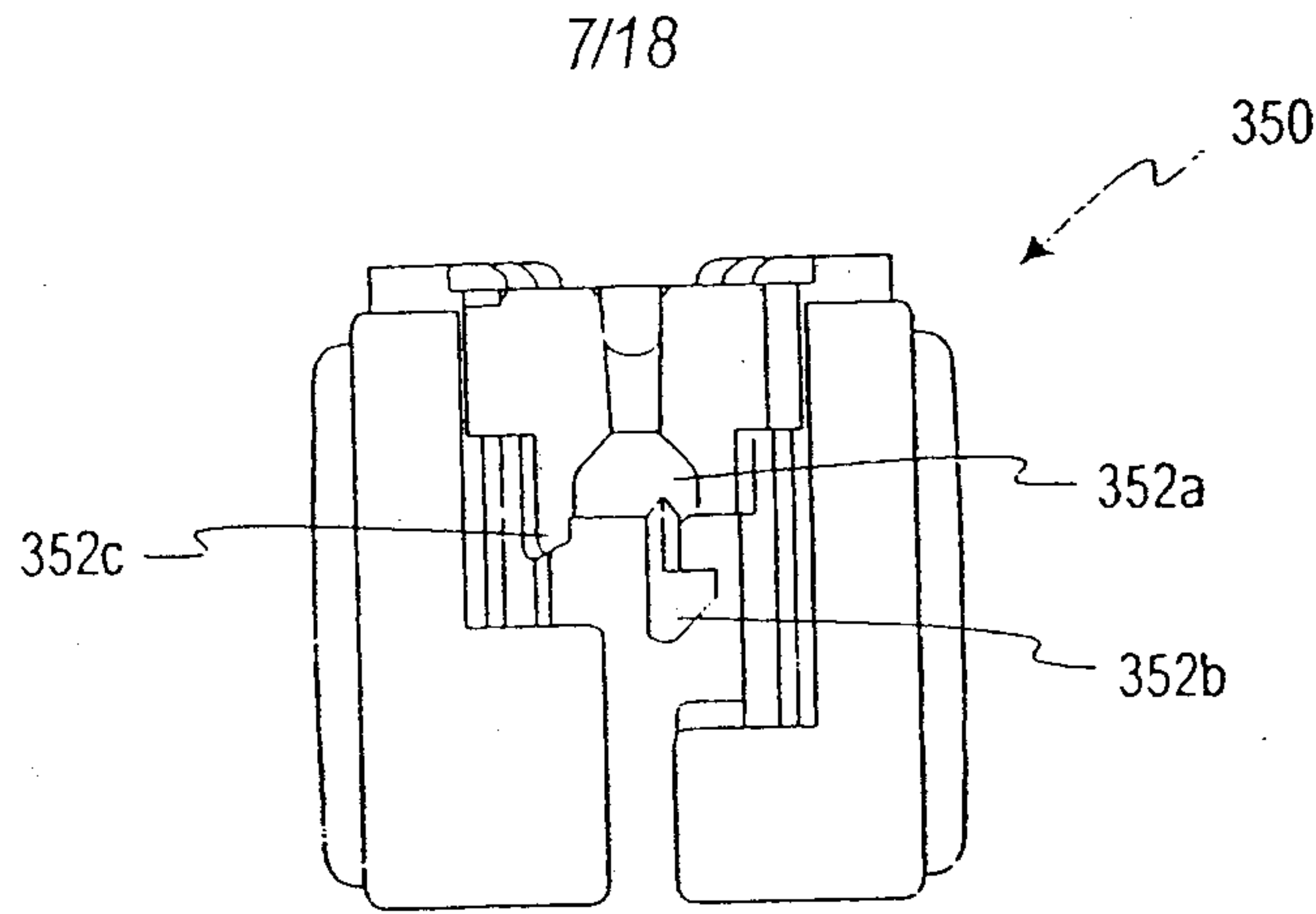
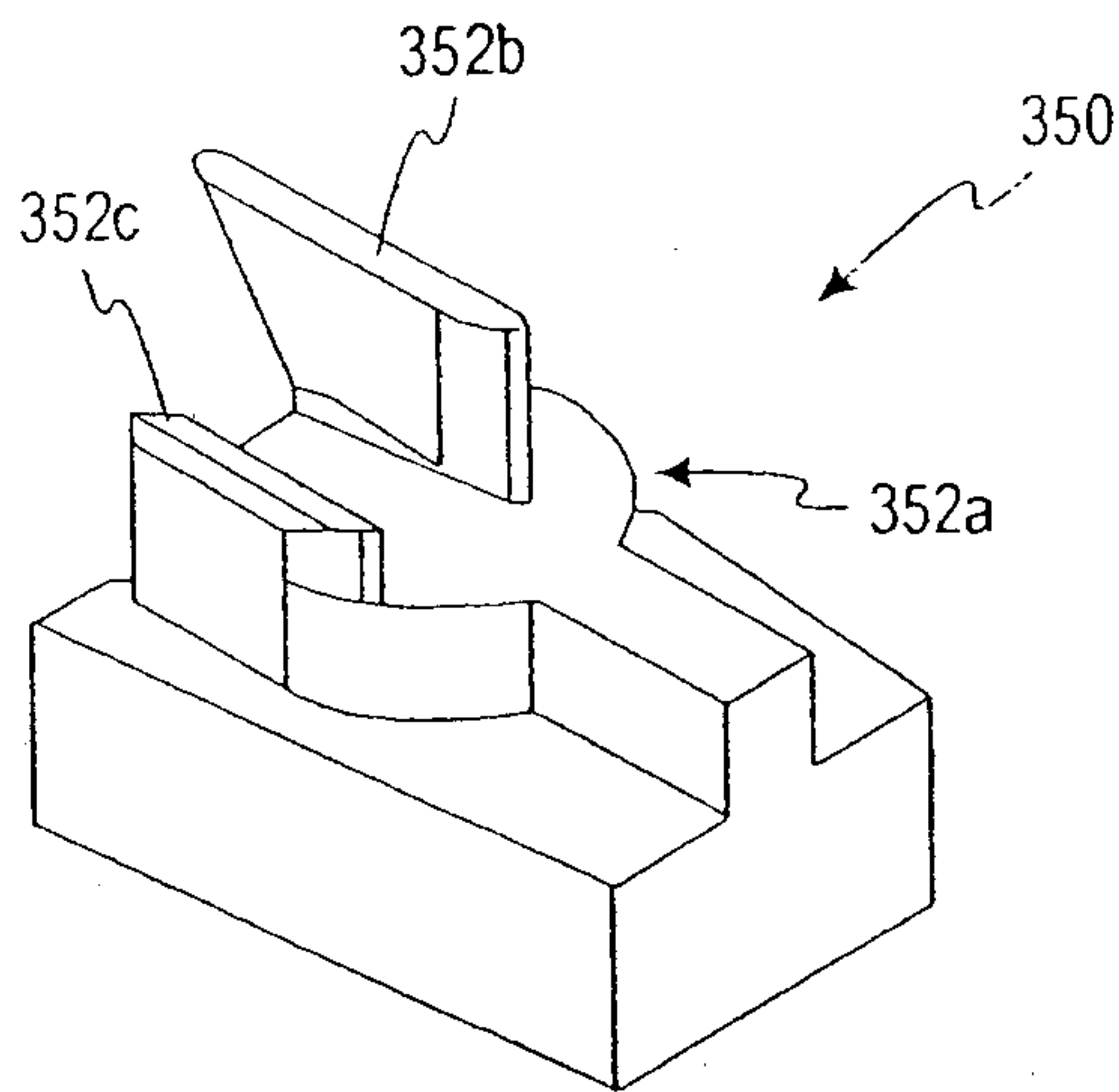


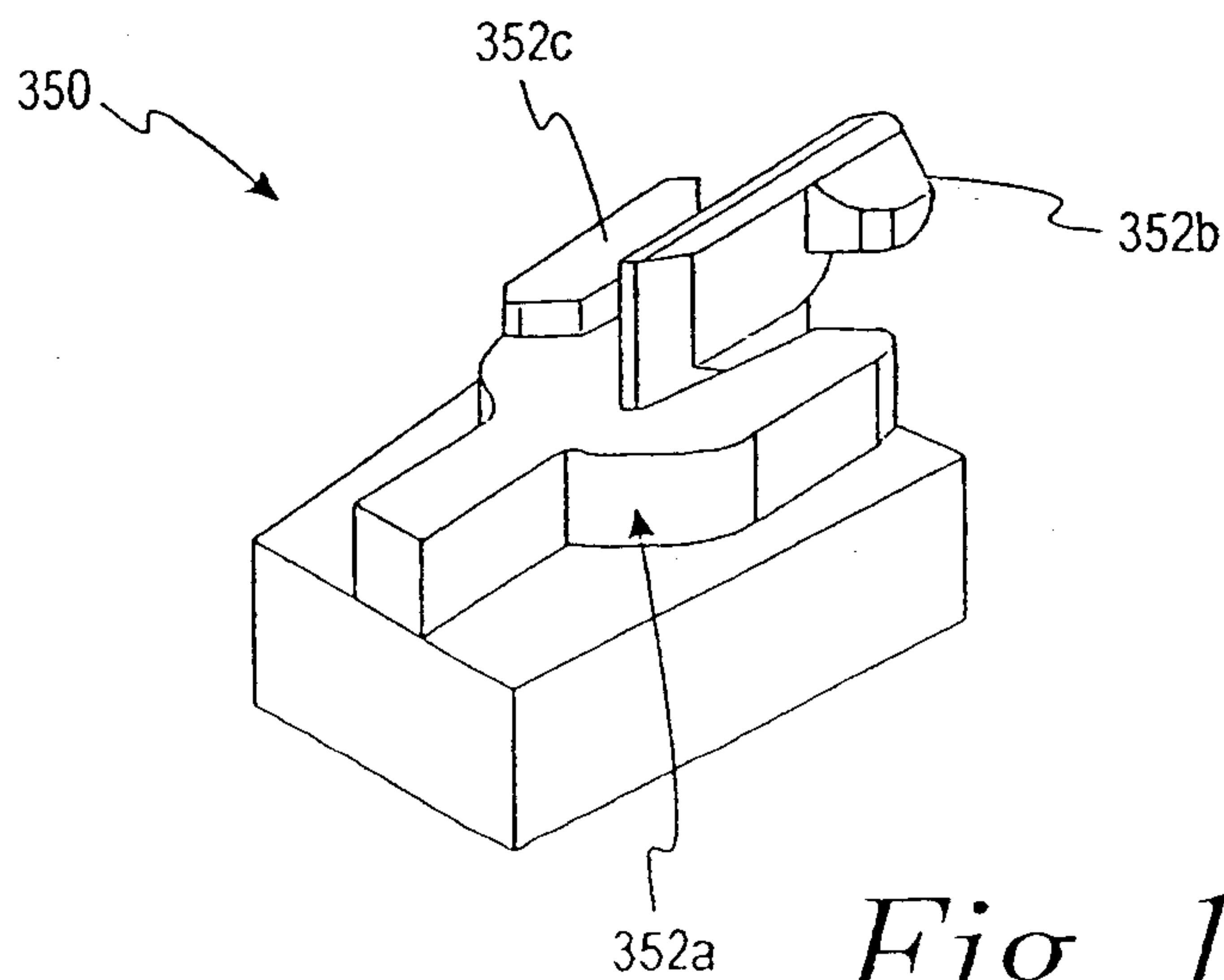
Fig. 11



*Fig. 12*



*Fig. 13a*



*Fig. 13b*

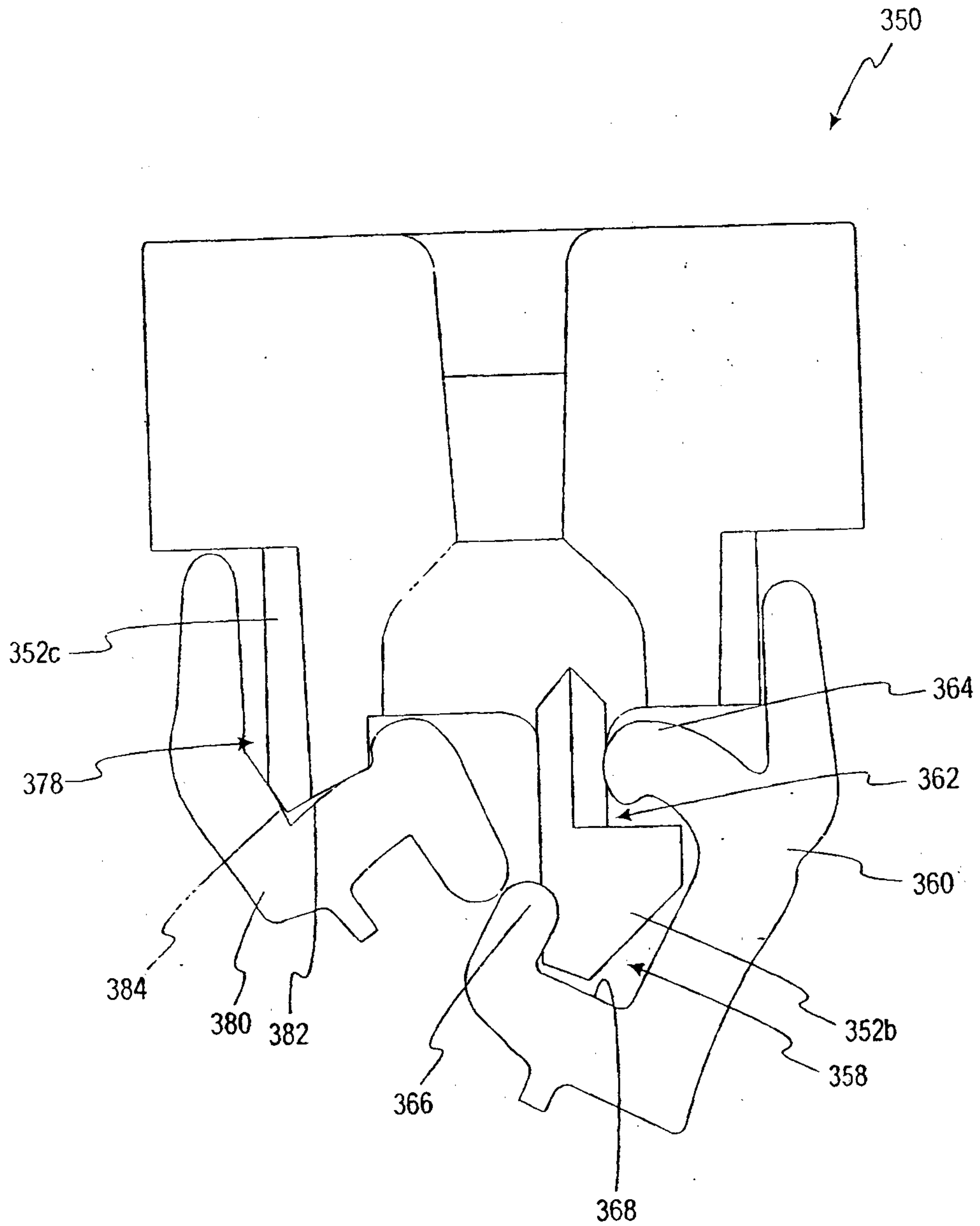
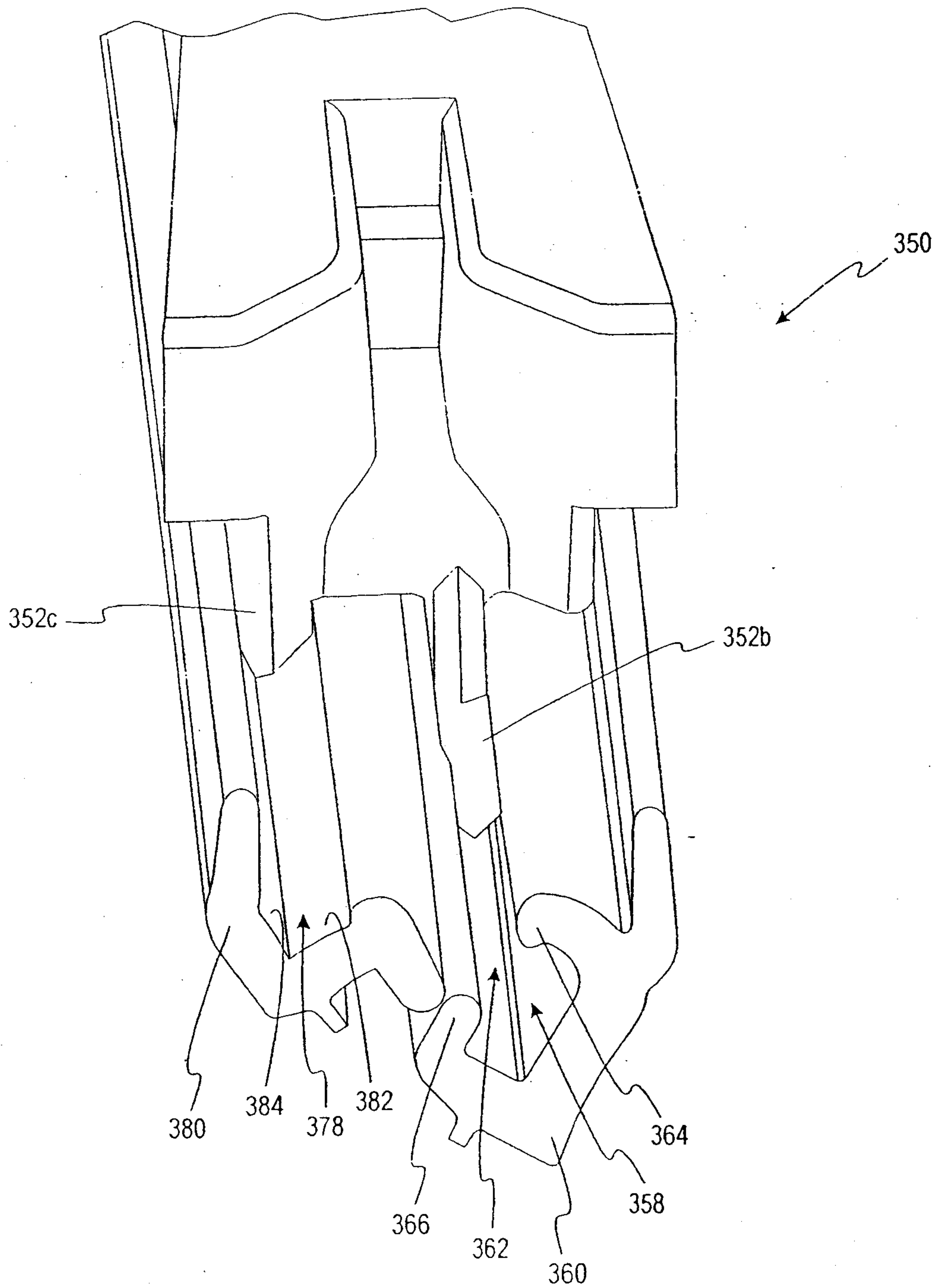


Fig. 14

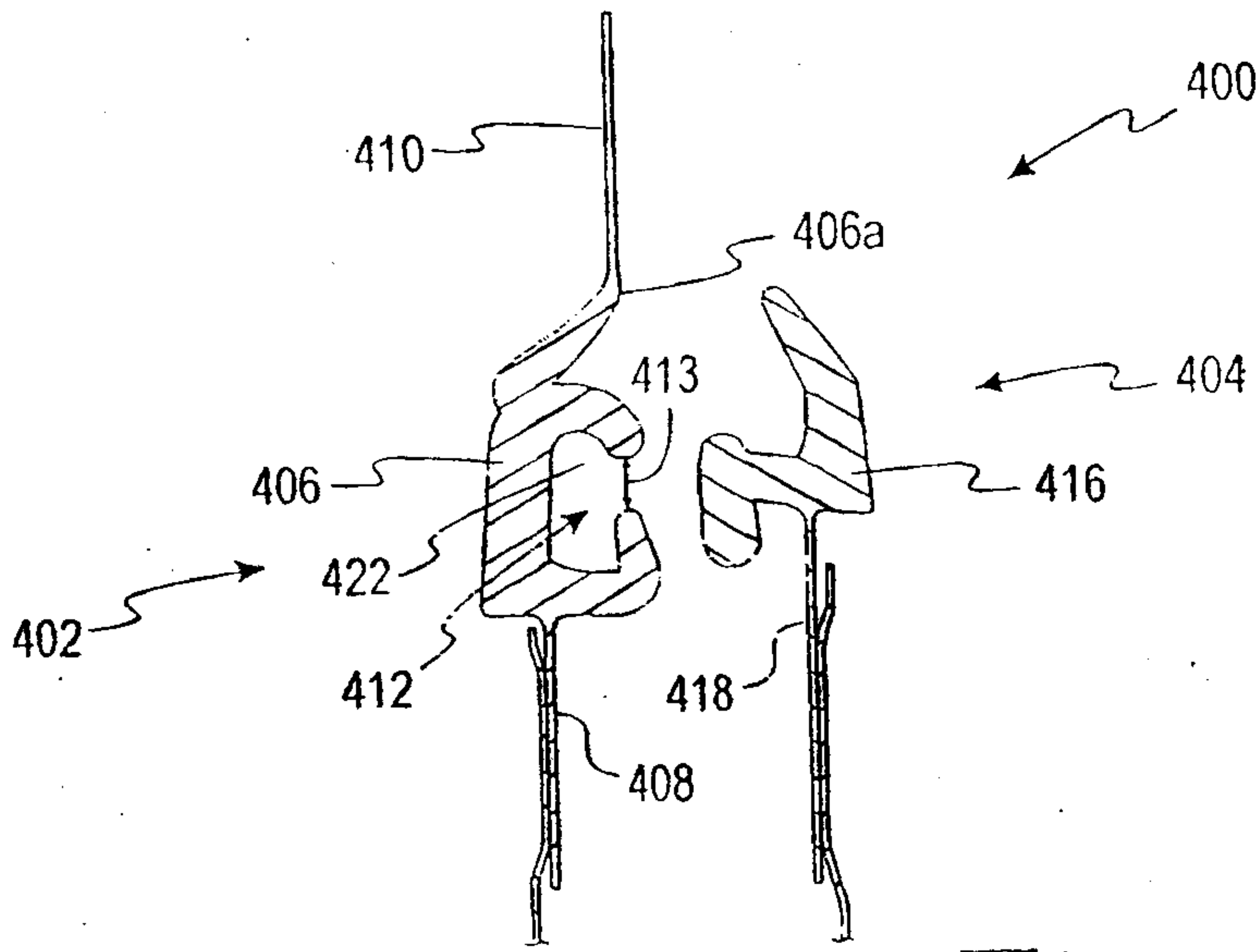


9/18

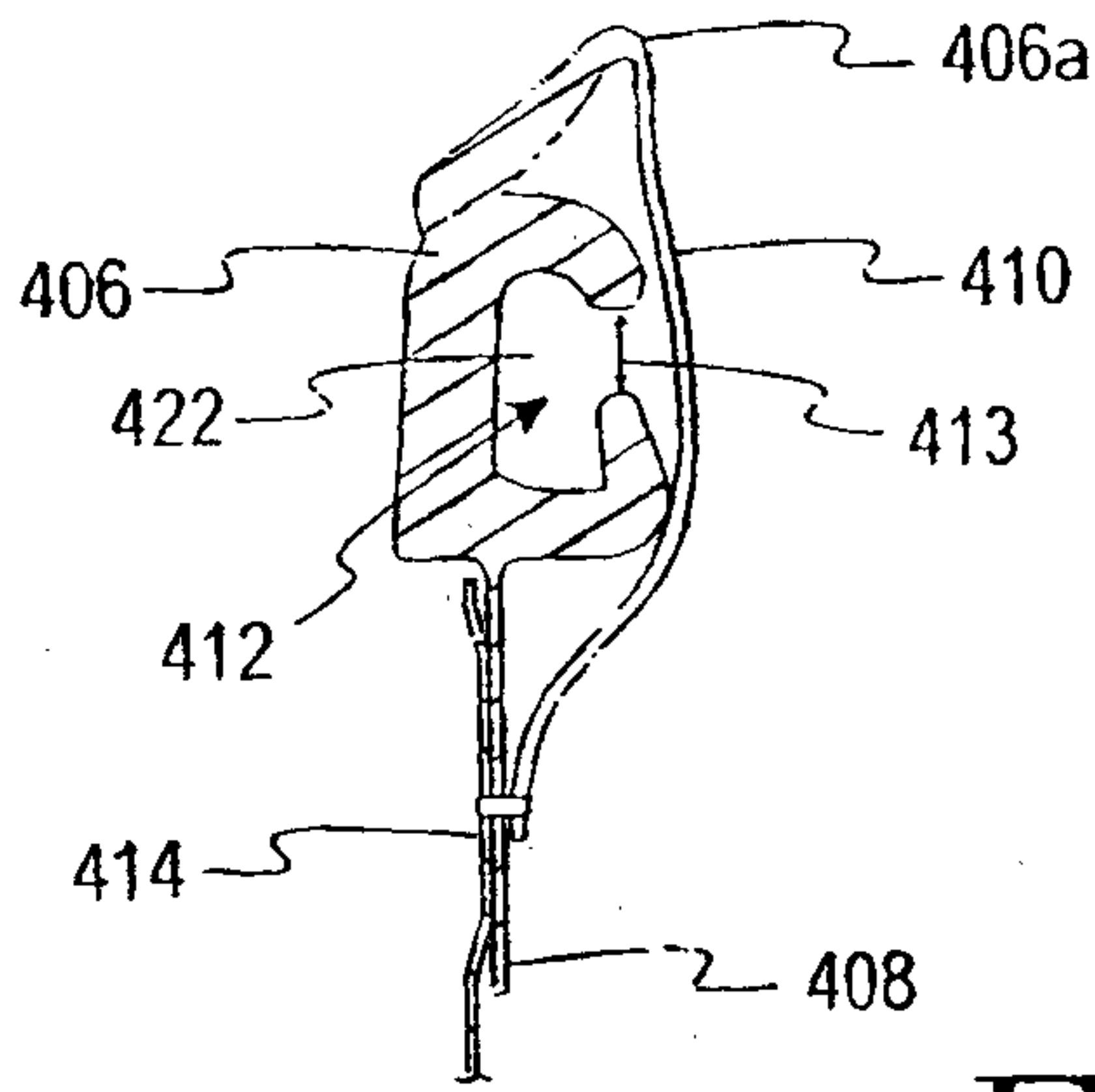


*Fig. 15*

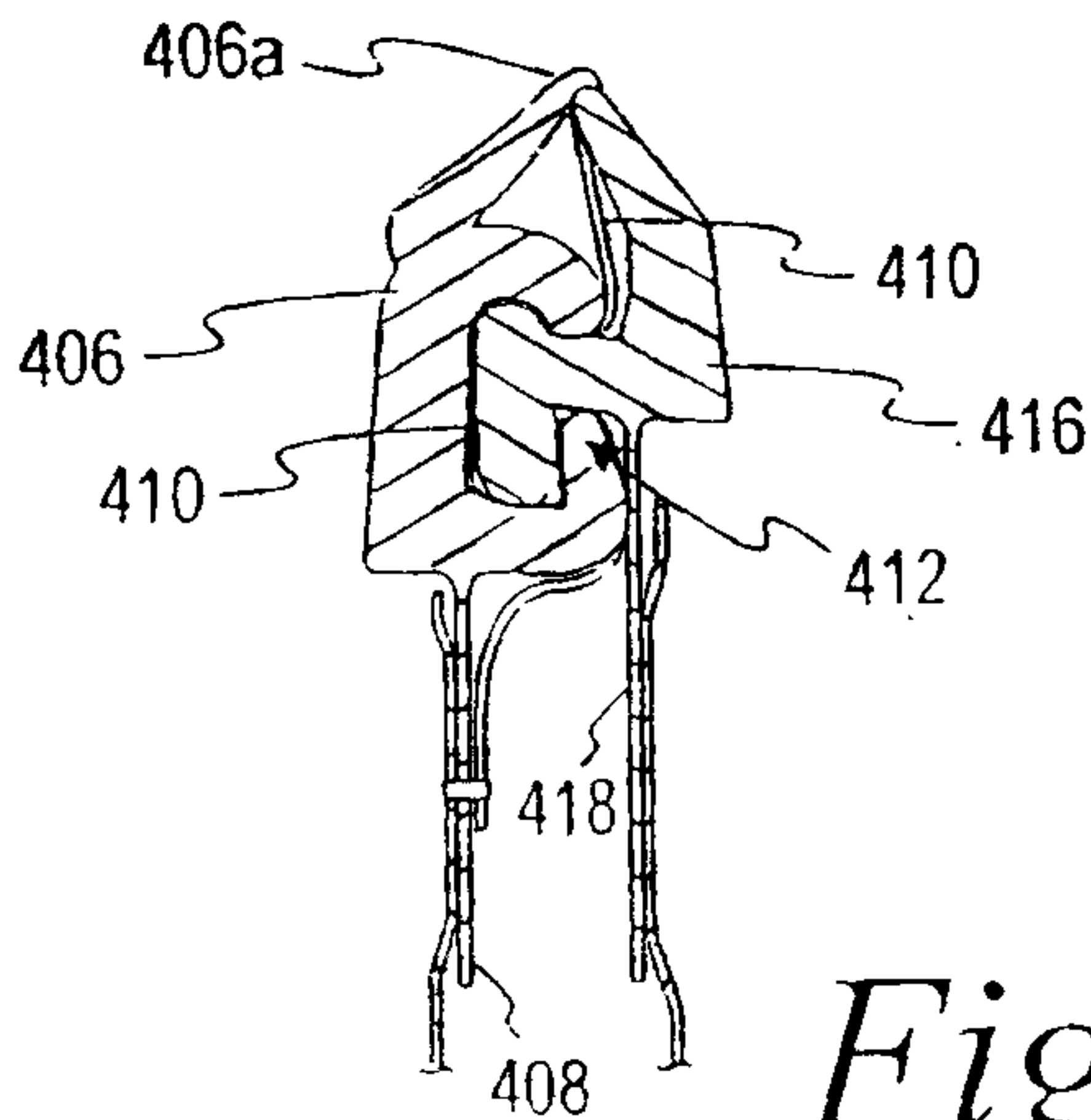
10/18



*Fig. 16*

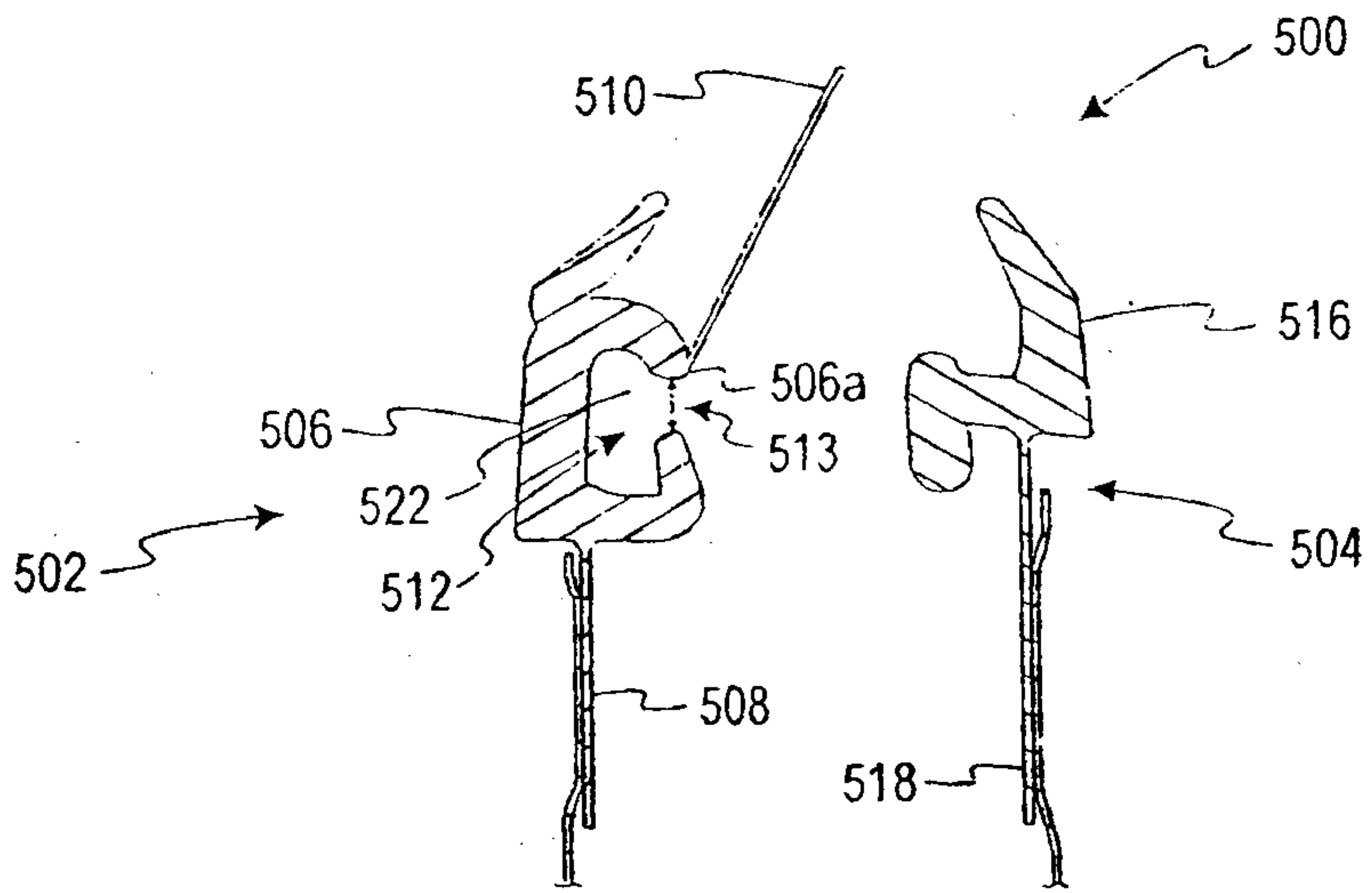


*Fig. 17*

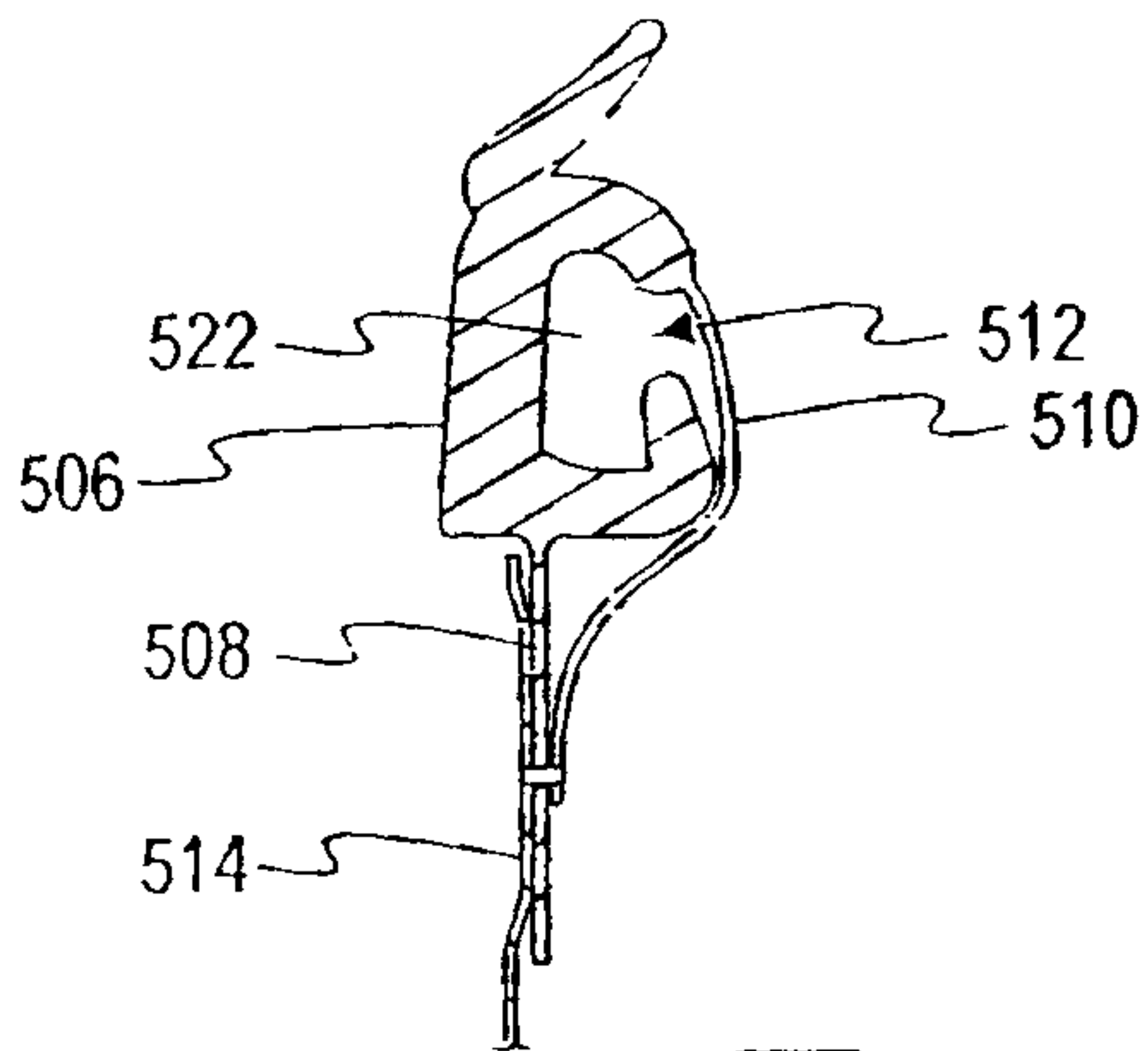


*Fig. 18*

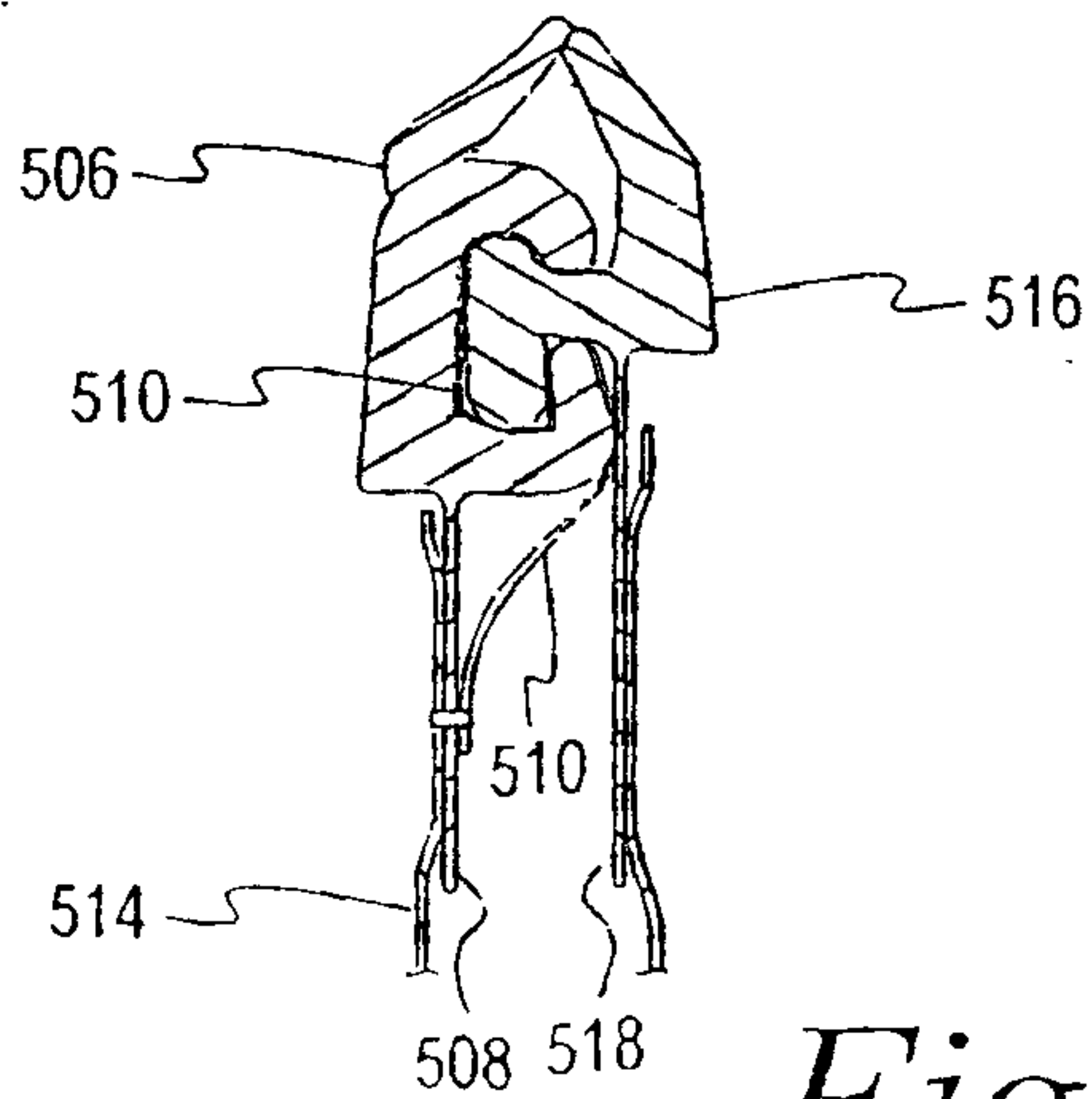
11/18



*Fig. 19*

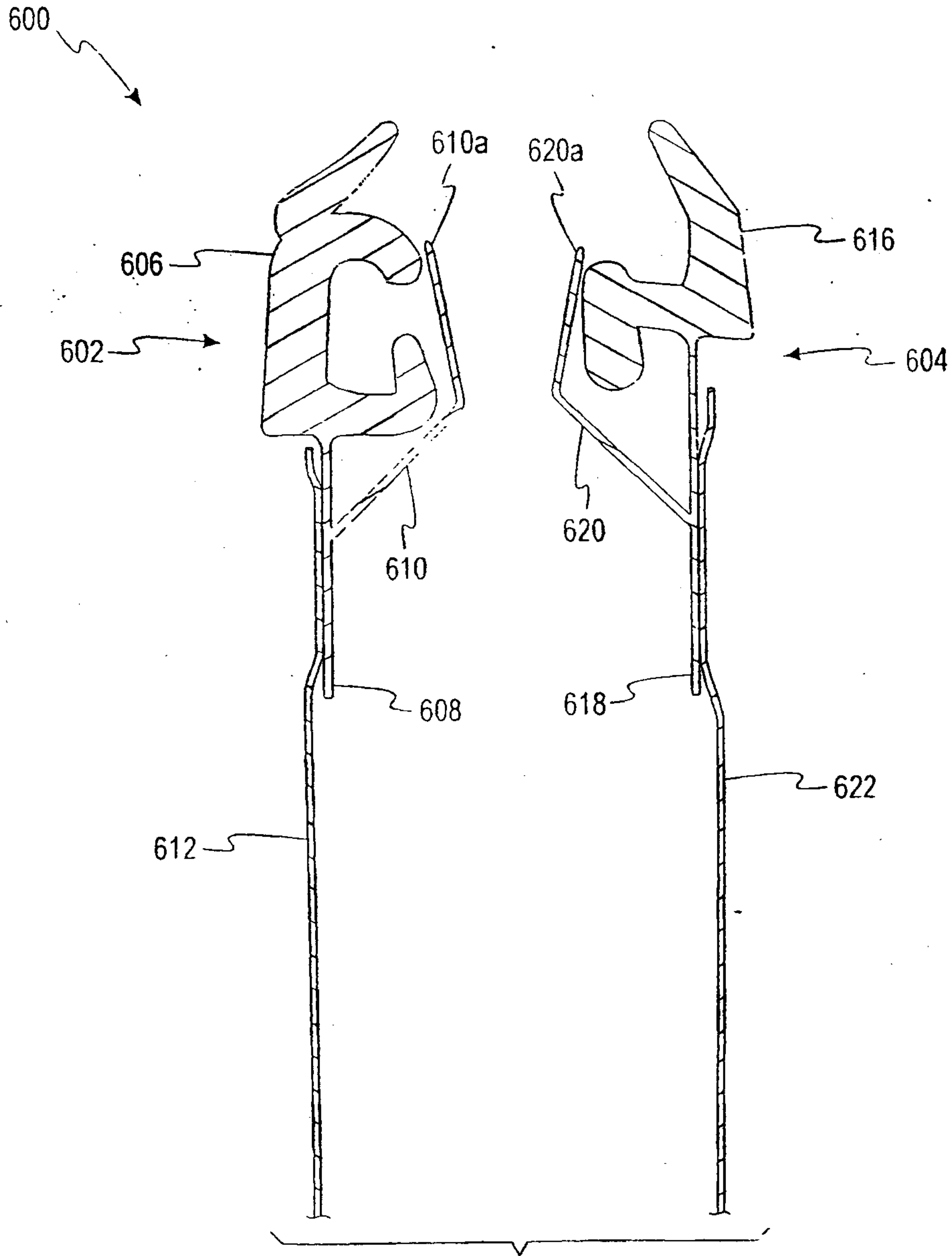


*Fig. 20*



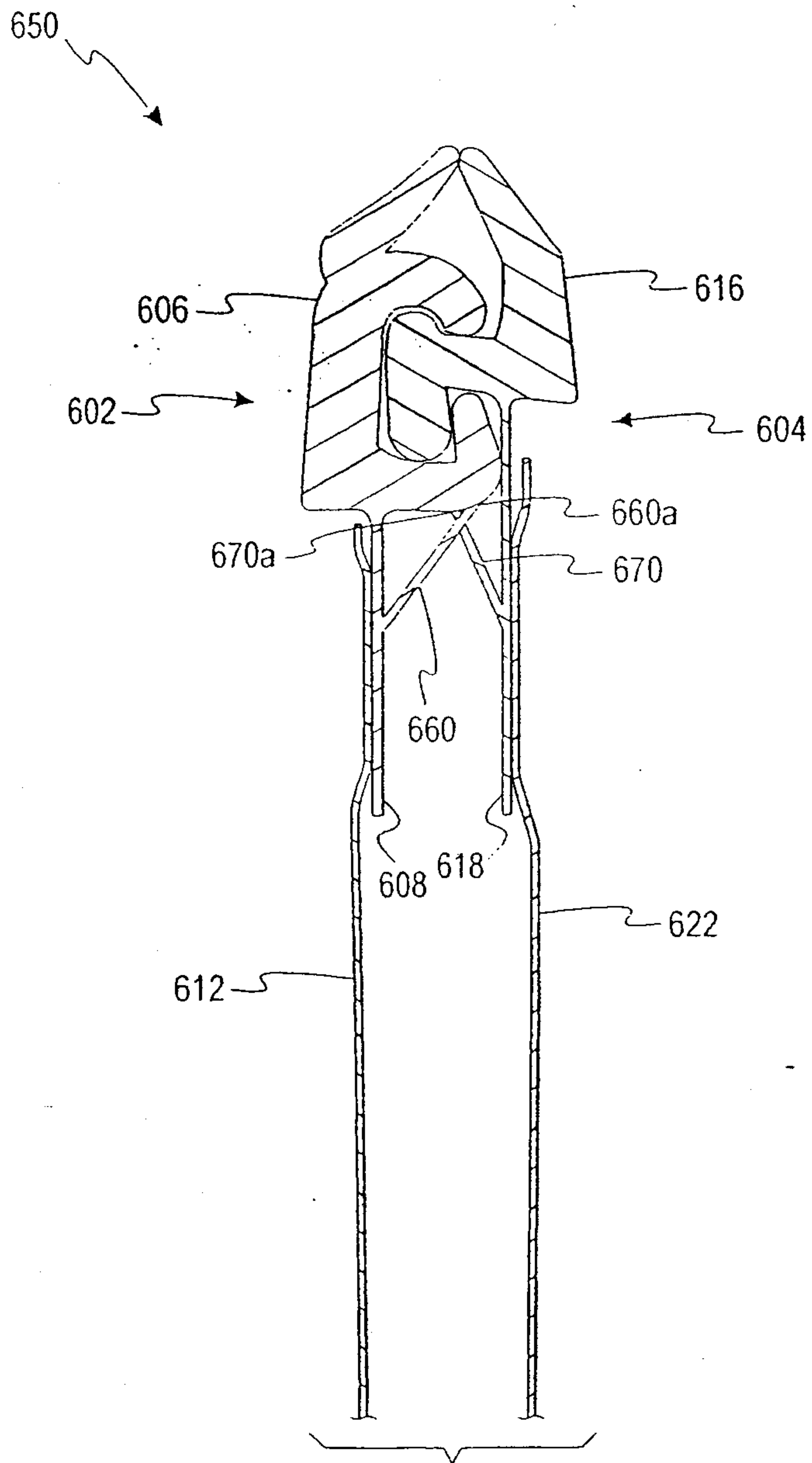
*Fig. 21*

12/18

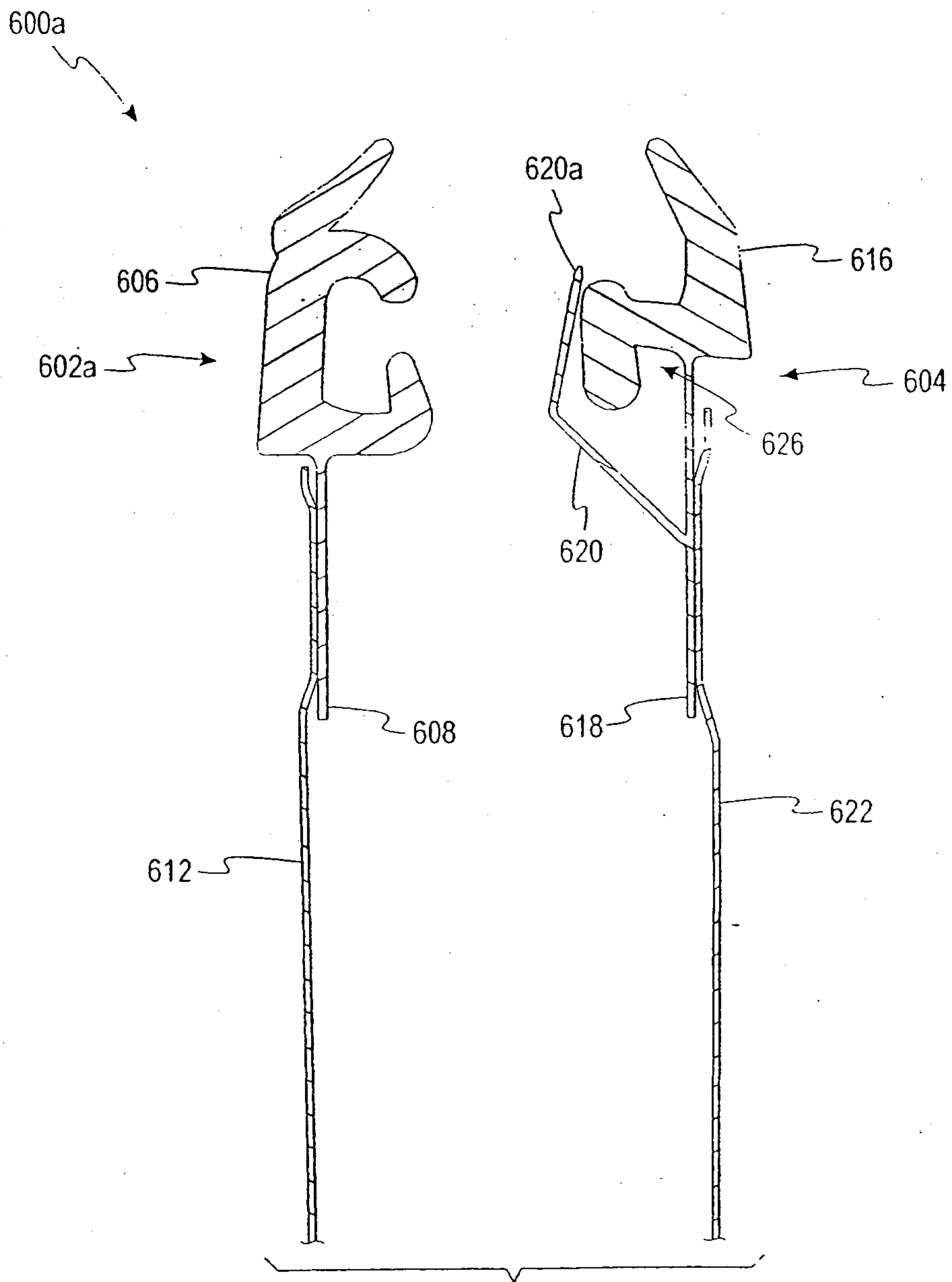


*Fig. 22a*

13/18

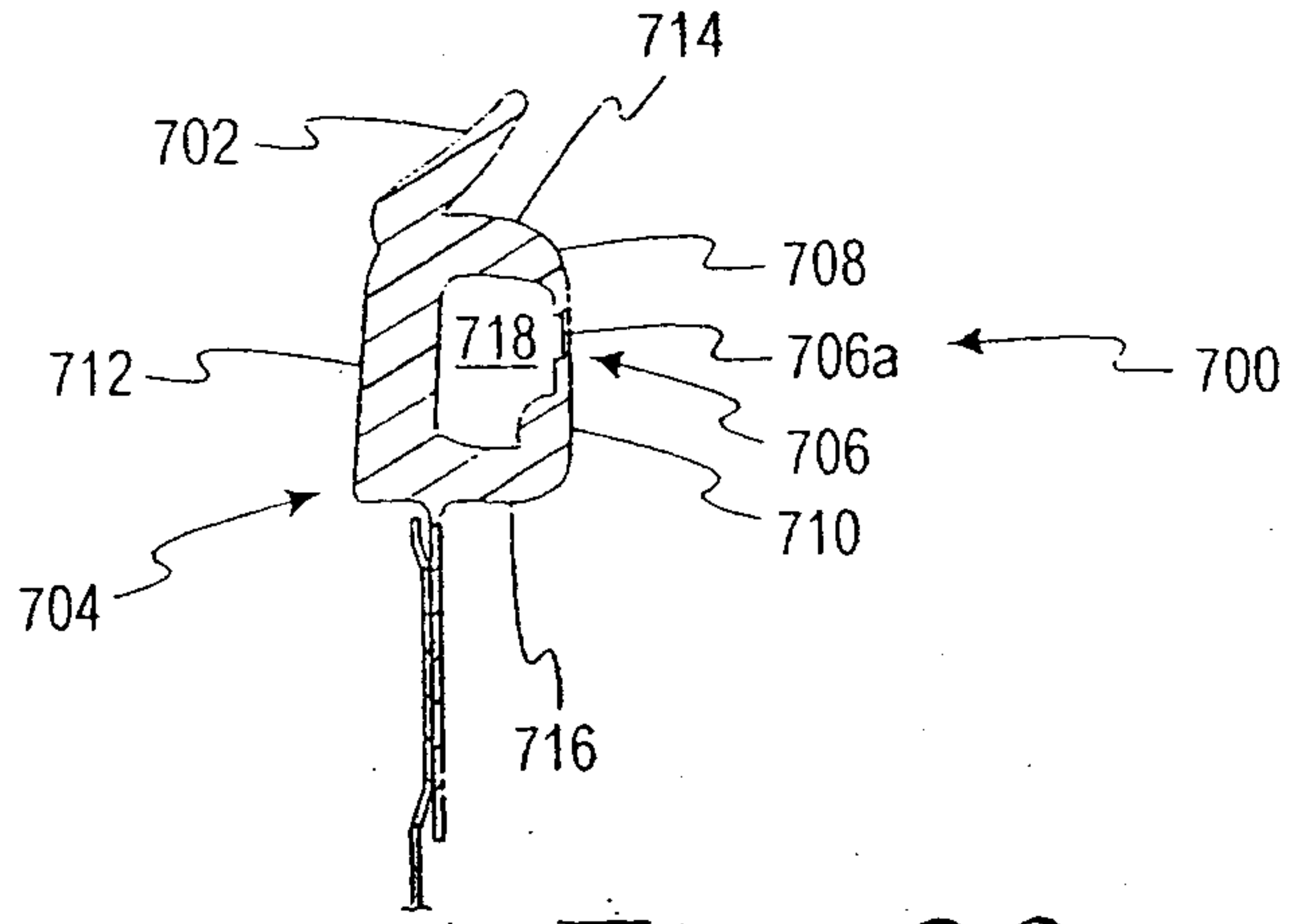


*Fig. 22b*

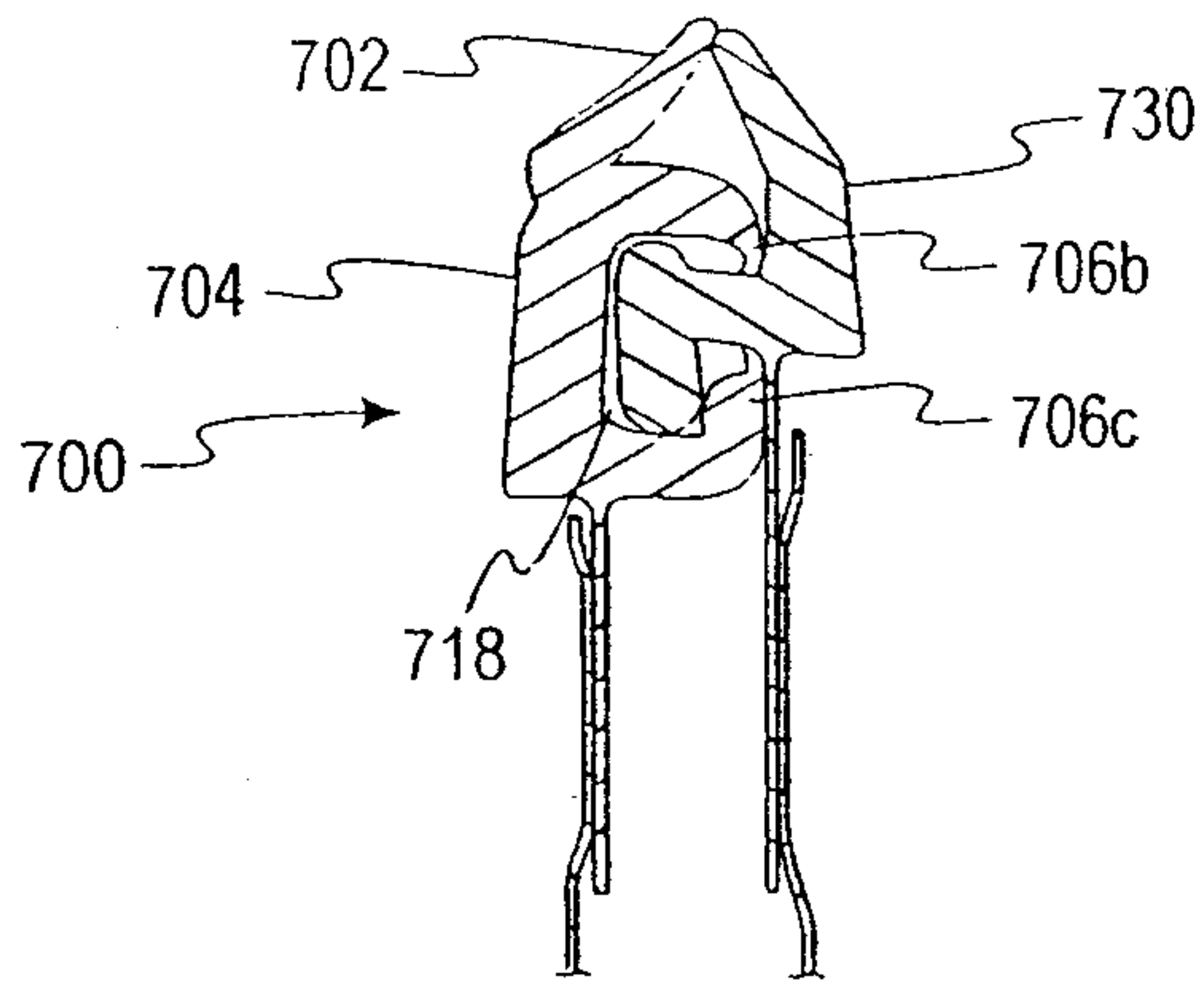


*Fig. 22c*

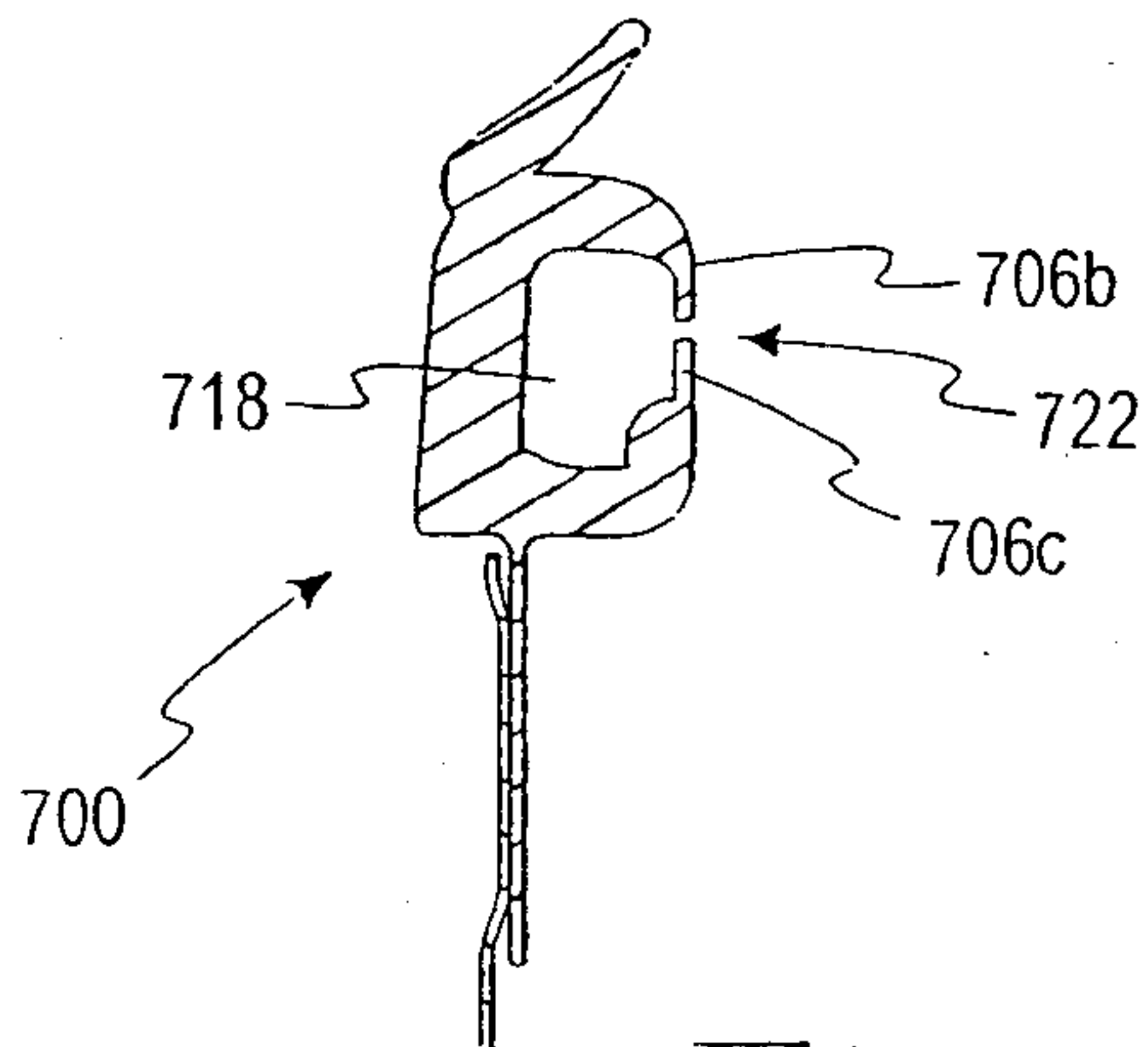
15/18



*Fig. 23*

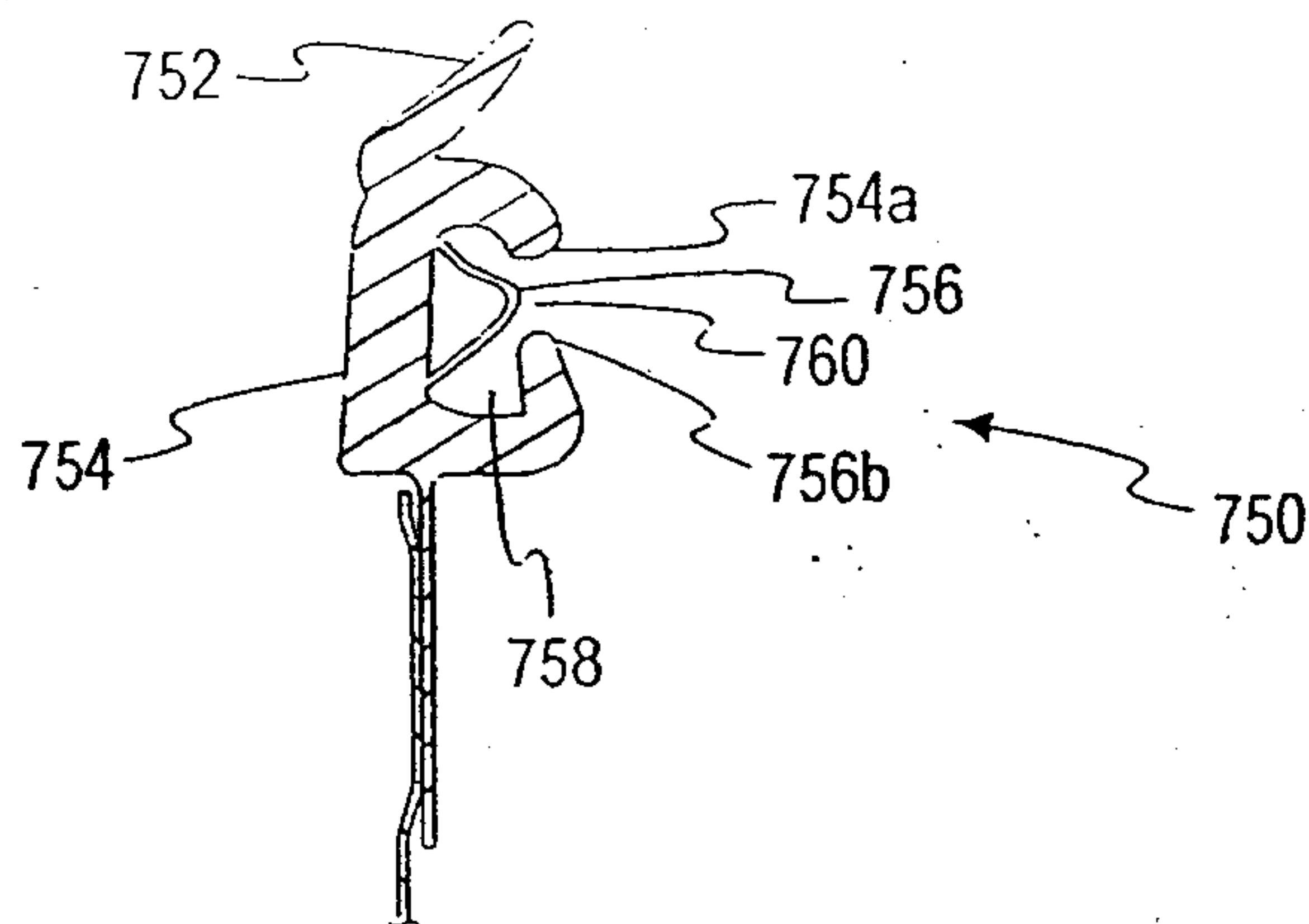


*Fig. 24*

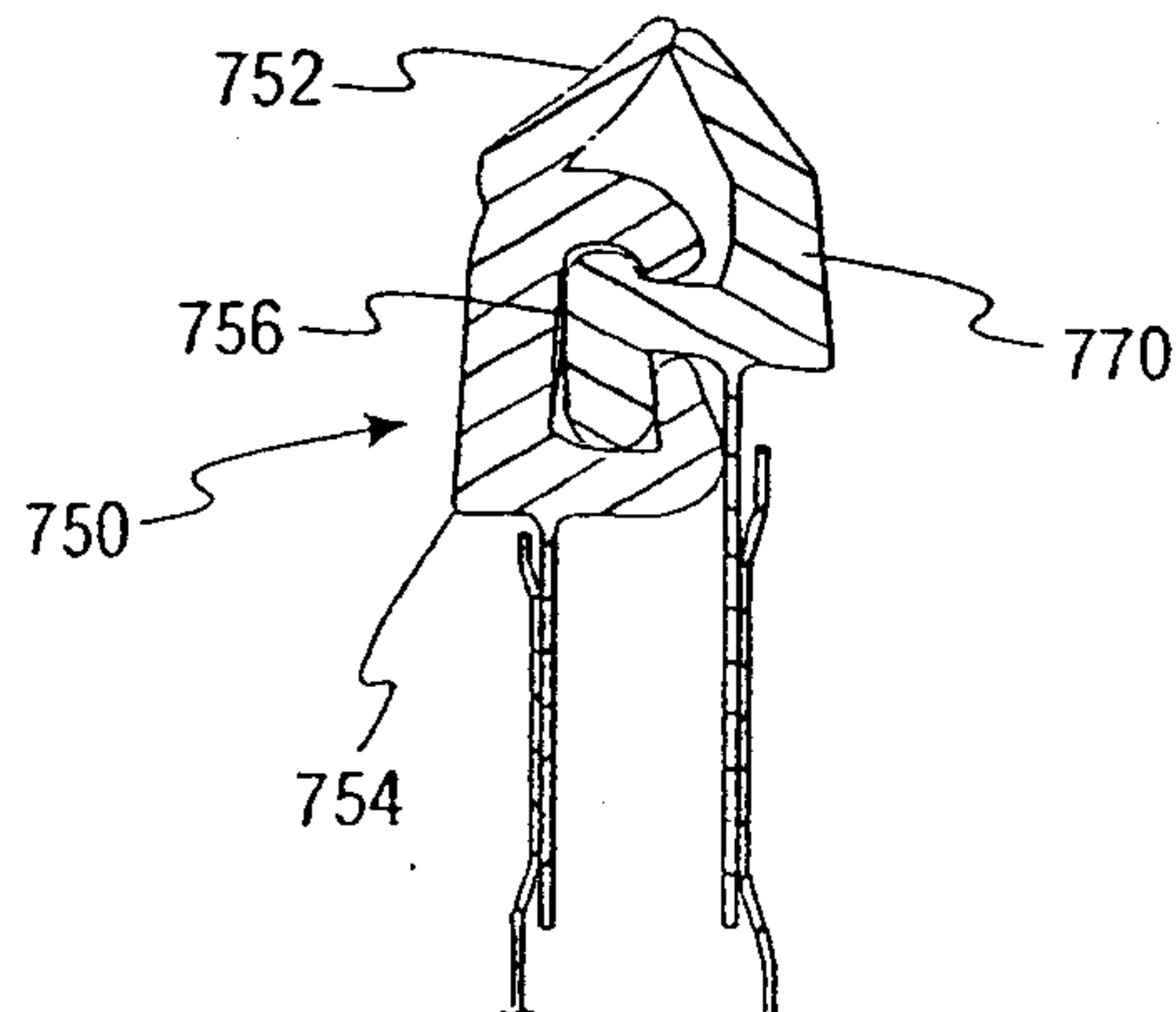


*Fig. 25*

16/18



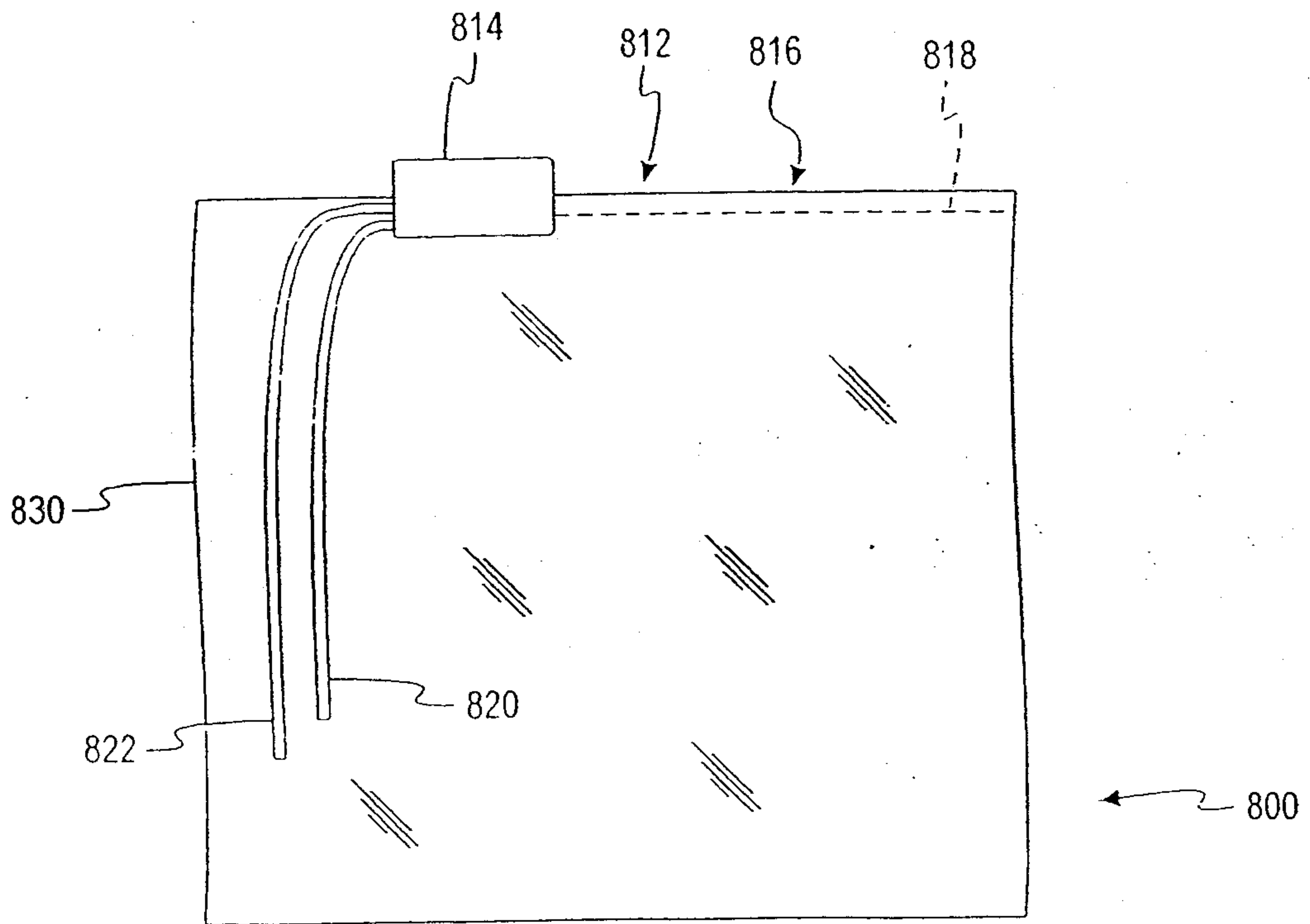
*Fig. 26*



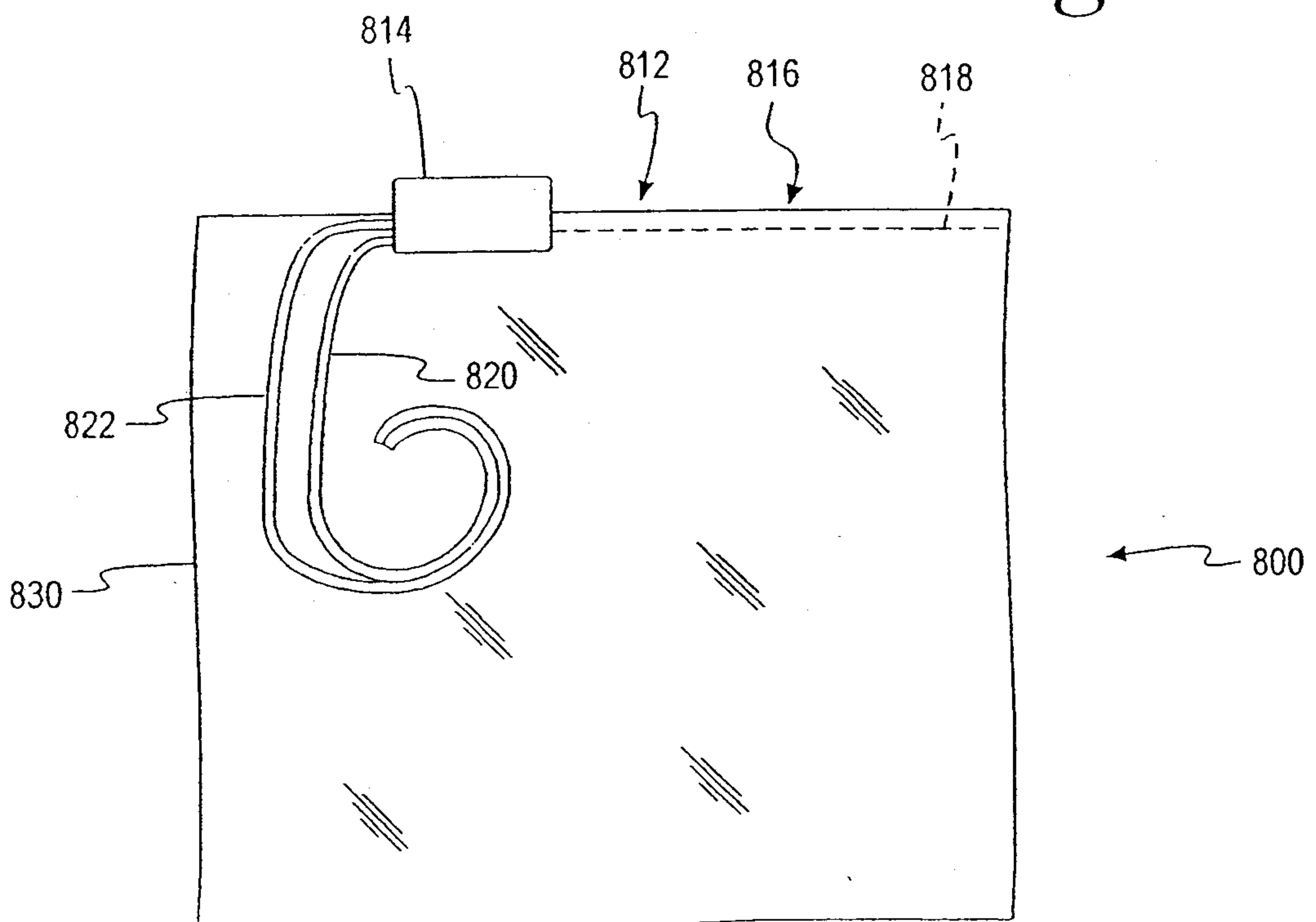
*Fig. 27*



17/18



*Fig. 28*



*Fig. 30*

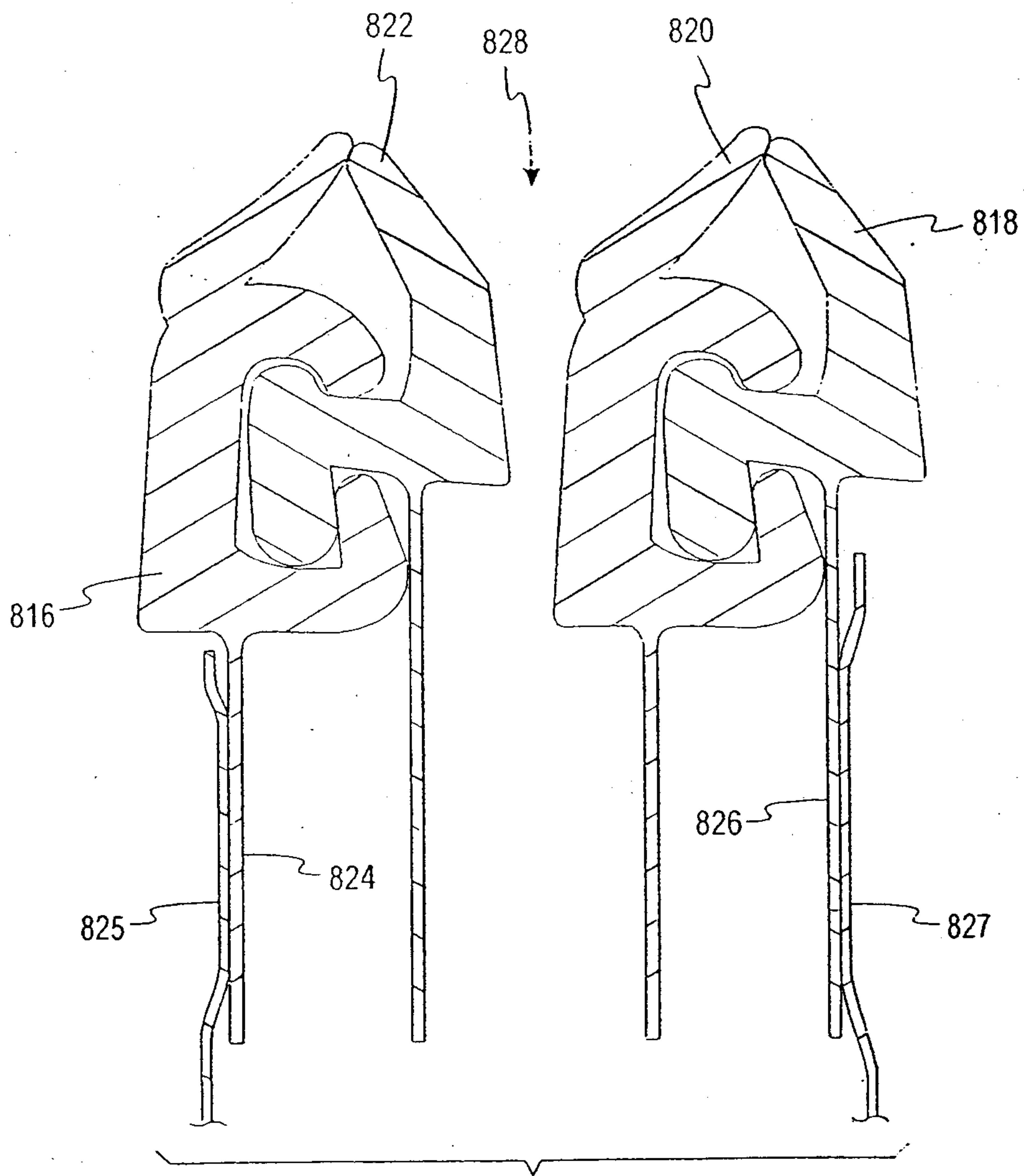


Fig. 29

