



Europäisches Patentamt
European Patent Office
Office européen des brevets



Publication number: **0 257 988 B1**

12

EUROPEAN PATENT SPECIFICATION

- 45 Date of publication of patent specification: 03.03.93 51 Int. Cl.5: G03B 17/56
21 Application number: 87307375.3
22 Date of filing: 20.08.87

54 Camera panner.

- 30 Priority: 26.08.86 GB 8620625
43 Date of publication of application:
02.03.88 Bulletin 88/09
45 Publication of the grant of the patent:
03.03.93 Bulletin 93/09
84 Designated Contracting States:
AT BE CH DE ES FR GB GR IT LI LU NL SE
56 References cited:
DE-A- 3 308 126 DE-B- 1 125 274
DE-B- 2 657 393 DE-C- 1 014 428
US-A- 3 782 671 US-A- 4 673 268

- 73 Proprietor: Maxwell Electronics Limited
Maxwell Industrial Building 350 Kwun Tong
Road
Kowloon(HK)
72 Inventor: Bittner, Wilfried Alois Anton
Flat C2, 12th Floor, Nam Hong Building
23 Hong Lee Road, Kwun Tong, Kowloon(HK)
74 Representative: Higgins, Michael Roger et al
MARKS & CLERK 57/60 Lincoln's Inn Fields
London WC2A 3LS (GB)

Note: Within nine months from the publication of the mention of the grant of the European patent, any person may give notice to the European Patent Office of opposition to the European patent granted. Notice of opposition shall be filed in a written reasoned statement. It shall not be deemed to have been filed until the opposition fee has been paid (Art. 99(1) European patent convention).

Description

The present invention relates to a powered panner for movie and video cameras. Such panners may also be used with telescopes, binoculars, still cameras and the like.

In particular, the invention relates to a panner which is arranged to be mounted on a tripod, a camera or the like being mounted on the panner so that relative motion between the camera and tripod can be effected.

Document US-A-3,782,671 discloses a camera panner which includes a base and a support onto which a camera or the like can be locked. This arrangement allows the movement of the base around a vertical axis and the rotation of the support around a horizontal axis. Said movements are made possible by means of two sets of drive means based on the use of a number of gearing components. Document DE-A-33,08,126 shows a camera panner having a support and a base allowing movement of said parts around a horizontal and vertical axis respectively. The movement is made possible by two motors.

The present invention provides a panner or the like as claimed in claim 1.

Preferred embodiments of the invention are disclosed in the dependent claims.

Other preferred features and advantages of the invention will be apparent from the following description.

The invention will be further described by way of example with reference to the accompanying drawings, in which:-

Figure 1 is a schematic side view of a panner according to the invention;

Figure 2 is a schematic end view of the panner of Figure 1;

Figure 3 is a schematic view not to scale, illustrating a drive mechanism for tilting a camera platform of the panner;

Figure 3a is a detail of Figure 3;

Figure 4 is a schematic view not to scale illustrating a drive mechanism for rotating a housing of the panner relative to a base thereof; and

Figures 5a and 5b together show an exploded perspective view of the panner illustrating the assembly thereof.

Figure 1 is a schematic side view of a panner according to the invention, comprising a base 1, housing 2 and camera support 3.

The housing 2 comprises a plastics, cylindrical inner portion 4 which houses drive motors for rotating the housing relative to the base 1, and tilting the support 3 relative to the housing. On opposite sides of the cylindrical portion 4 are integrally moulded plastics chambers 5, 6 for housing batteries to form a power supply and electronic con-

trols respectively. The cylindrical portion 4 is closed at its upper end 8, save for a slot 9 which receives an arm 10 of the support 3.

Support 3 comprises a platform 11 on which a camera, telescope etc. can be mounted. The platform 11 carries a screw (see Figure 5a) for securing a camera to the platform as generally used on tripods, it may also carry a retractable pin (see Figure 5a) for use in aligning cameras having an aperture for such a pin. Support 3 is pivotably mounted at each side on pins 12 which are fast in arms 13 which extend up from and are integrally formed with the cylindrical portion 4.

Arm 10 is integral with the platform 11 and extends down through slot 9 into the cylindrical portion 4. Arm 10 is bifurcated at its lower end 14 to receive a pin 15 which is reciprocated along an arc to reciprocate the end 14 of the arm 10 and hence to tilt the platform 11.

Preferably the platform is tiltable through an angle of + and - 15 degrees from a mean position parallel to the base.

The base 1 comprises a moulded plastics cup 16 which is a close fit in the bottom of the cylindrical portion 4. Cup 16 carries means for mounting the base on a tripod or the like, as is commonly known. The base may of course simply be set on a flat surface. The cup has a top sidewall 17 which carries degree markings 18 which are visible through an aperture 19 in the wall of the cylindrical portion 4.

Means for driving the pin 15 to tilt the platform 11 and for rotating the housing relative to the base will now be described.

Referring to Figure 3, a sheet metal back plate 20 carries a small, 6 volt permanent magnet direct current (PMDC) motor 21 which is mounted behind the plate. A shaft of the motor projects through an aperture 23 in the plate 20 and carries a worm 22 which meshes with a first wormwheel 24. Wormwheel 24 is mounted fast on a shaft 25 which rotates in two ears 26 which are pressed from the plate 20. Also fast on the shaft 25 is a second worm 27 which meshes with a final drive wormwheel 28. Mounted on wormwheel 28 is a circular plate 29 carrying an arm 30 which carries at its end the pin 15. Wormwheel 28 and plate 29 are rotatable on a central shaft 31. A wavy washer is located between the wormwheel 28 and plate 29 and compressed therebetween to form a friction clutch transmitting drive from the wormwheel 28 to the plate 29, but allowing slip between the wormwheel and plate under high load conditions, for example if the plate is tilted manually.

The motor 21 is driven in forward and reverse directions to reciprocate pin 15 through an arc and so reciprocate arm 10 and platform 11.

Worm 27 is biased towards wormwheel 28 to ensure close meshing between the teeth of the wormwheel and the worm avoiding backlash.

Figure 3A is an end view of shaft 25 looking at ear 26b. Shaft 25 is carried in an oval or oblong hole 32 in ear 26b. A wire spring 33 is wound around shaft 25 and bears at its end on screws 34 which are secured into the ear 26b. Spring 33 thus urges the shaft 25 in the direction of worm 28. A degree of play is allowed where shaft 25 penetrates ear 26a to allow movement of the shaft 25 and so worm 27 towards the wormwheel 28.

The drive assembly of Figure 3 is mounted by screws or the like to the undersurface of the top of cylindrical portion 4.

Figure 4 is a schematic partially exploded view of the means for rotating the base relative to the housing.

A plastics disc 35 is arranged to be a snug fit inside the cylindrical portion 4. Disc 35 is inserted from underneath the direction of base 4, and attached to abutments formed on the housing wall, for example by screws. A shaft 36 is journaled in disc 35 and held against axial movement by collars 37 which are attached to the shaft by grub screws.

At the bottom end of the shaft 36, a plate member 38 comprising a lower disc 39, cylinder 40 and middle disc 41 is mounted fast on the shaft.

Cylinder 40 is reduced in diameter at the level of disc 41 and extends up the shaft 36 to form a sleeve. An upper plate 43 is attached to the upper end of cylinder 40. A final driven wormwheel 42 and a friction clutch 45 in the form of a wavy washer are mounted on cylinders 40 between upper disc 43 and middle disc 41.

Wormwheel 42 is driven by a 6V PMDC motor 44 carried by the disc 35 via a drive chain comprising a first worm 46 (mounted on the shaft of motor 44) which engages a wormwheel 47 mounted on the same shaft 48 as a second worm 49 which results with the wormwheel 42. This drive arrangement is identical in construction with that shown in Figure 3 and, as in the arrangement of Figure 3, includes spring means for biasing worm 49 towards wormwheel 42.

Accordingly, operation of the motor 44 rotates wormwheel 42 to rotate lower disc assembly 38 via the clutch 45. The clutch allows the disc assembly to be rotated without rotation of wormwheel 42 (which will not rotate as it is held by a worm).

Lower plate 39 is screwed to cup 16 to rotate the cup 16 relative to the disc 35, and hence the housing 2.

Also mounted on disc 35 are position sensing switches.

An arcuate plate 50 is carried on pillars 51 and has printed contacts 52 on its underside. A conducting leaf 53 is mounted on a metal pillar 54 on

metal disc 39 and wipes over the contacts 52 as the disc 39 rotates. Electrical continuity between the plate 39 and a respective contact 52 can be detected to indicate the angular position of the plate relative to the disc 35.

A limit stop 55 projects up from the cup 16 and is arranged to abut stops 56 on disc 35, to limit mechanically the angular rotations of the cup and disc assembly 38 relative to disc 35.

To assemble the panner, the two drive assemblies of Figures 3 and 4 are constructed and the support 3 is attached to the housing 2. The drive assemblies are then inserted into cylindrical portion 4 and disc 35 attached to the housing by screws, access being had from the direction of plate 39. The cup 16, base 1, is then attached to the disc 39.

Wiring from the motors and the position detectors 52, 53 is fed through to compartment 6. Control switches may be mounted on the compartment and a socket provided for a lead wire to a remote control.

As indicated previously the circuitry may provide for various modes of operation: manual control via the remote control; automatic panning through predetermined angles such as 30°, 60°, 90°, by virtue of position switches 37, and automatic centering at 0°.

Various modifications will be apparent to those in the art and it is desired to include all such modifications as fall within the scope of the accompanying claims.

Claims

1. An electrically powered panner for a camera or the like comprising:
 - a base (1);
 - a housing (2) mounted on the base (1);
 - first and second drive means (42, 44, 46, 47 & 49; 15, 21, 22, 24 & 27-29) wholly contained within the housing (2); the first drive means (42, 44, 46, 47 & 49) comprising: an electric motor (44) including a motor shaft, the motor (44) being fixed relative to the housing (2), a worm (46) on the motor shaft, a first wormwheel (47) in mesh with the worm (46), a second worm (49) co-axial with and connected to the first wormwheel (47), a second wormwheel (42) in mesh with the second worm (49), the second wormwheel (42) being drivingly connected to the base (1) such that upon actuation of the motor (44), the base (1) is rotated relative to the housing (2) about a first axis; the second drive means (15, 21, 22, 24 & 27-29) comprising: an electric motor (21) including a motor shaft, the motor (21) being fixed relative to the housing (2), a worm (22) on the

- motor shaft, a first wormwheel (24) in mesh with the worm (22), a second worm (27) coaxial with and connected to the first wormwheel (24), a second wormwheel (28) in mesh with the second worm (27), a first arm (30) mounted on the central axis of the second wormwheel (28) such that rotation thereof causes swinging movement of the first arm (30); a support (3) for the camera or the like mounted above the housing (2) to pivot about a second axis perpendicular to the first axis; and
- a second arm (10) extending from the support (3) into the housing (2), the distal end (14) of the second arm (10) being drivingly connected to the distal end of the first arm (30) such that upon actuation of the second drive means (15, 21, 22, 24 & 27-29) the second arm (10) and hence the support (3) rotates about the second axis.
2. A panner as claimed in Claim 1, wherein each worm (22, 27, 46 or 49) is biased towards a respective wormwheel (24, 28, 47 or 42).
 3. A panner as claimed in Claim 1 or Claim 2, wherein a friction clutch (45) is provided in the first drive means (42, 44, 46, 47 & 49) between the housing (2) and the base (1).
 4. A panner as claimed in Claim 3, wherein the friction clutch (45) comprises a wavy washer compressingly sandwiched between a first and a second plate (43 & 41), the first plate (43) being drivingly connected to the second wormwheel (42) of the first drive means (42, 44, 46, 47 & 49) and the second plate (41) being drivingly connected to the base (1), the arrangement affording manual rotation of the base (1) relative to the housing (2) without rotation of the second wormwheel (42).
 5. A panner as claimed in Claim 1, in which the first arm (30) has a pin (15) on the distal end thereof and the distal end (14) of the second arm (10) is bifurcated, the arrangement being such that the pin (15) locates in the bifurcated end (14) of the second arm (10) to thereby drivingly connect the second wormwheel (28) of the second drive means (15, 21, 22, 24 & 27-29) to the distal end (14) of the second arm (10).
 6. A panner as claimed in Claim 1, wherein the first drive means (42, 44, 46, 47 & 49) is mounted on a platform (35) housed in and attached to the housing (2), the electric motor (44) of the first drive means (42, 44, 46, 47 &

49) being mounted above the platform (35) and the first and second worms (46 & 49) and first and second wormwheels (47 & 42) being mounted below the platform (35), the second drive means (15, 21, 22, 24 & 27-29) being mounted above the platform (35).

7. A panner as claimed in Claim 1, wherein position sensing electrical contacts (52) are provided for sensing when the base (1) and housing (2) reach predetermined relative positions.
8. A panner as claimed in Claim 1, including remote control means for controlling remotely each drive means (42, 44, 46, 47 & 49 or 15, 21, 22, 24 & 27-29).
9. A panner as claimed in Claim 1, including automatic control means for controlling the first drive means (42, 44, 46, 47 & 49) and the second drive means (15, 21, 22, 24 & 27-29) according to a preset programme.

Patentansprüche

1. Elektrisch angetriebener Schwenkkopf für eine Kamera oder dergleichen, aus:
 - einer Grundplatte (1);
 - einem auf der Grundplatte (1) angebrachten Gehäuse (2);
 - einem ersten und zweiten Antriebsmittel (42, 44, 46, 47 & 49; 15, 21, 22, 24 & 27-29), die in dem Gehäuse (2) vollständig untergebracht sind; wobei das erste Antriebsmittel (42, 44, 46, 47 & 48) umfaßt: einen Elektromotor (44), der eine Motorwelle aufweist, wobei der Motor (44) an dem Gehäuse (2) befestigt ist, eine auf der Motorwelle angebrachte Schnecke (46), ein erstes Schneckenrad (47), das in Eingriff mit der Schnecke (46) steht, eine zweite Schnecke (49), die koaxial zu dem ersten Schneckenrad (47) ist und damit verbunden ist, ein zweites Schneckenrad (42), das in Eingriff mit der zweiten Schnecke (49) steht, wobei das zweite Schneckenrad (42) mit der Grundplatte (1) so verbunden ist, daß bei Betätigung des Motors (44) die Grundplatte (1) relativ zu dem Gehäuse (2) um eine erste Achse gedreht wird; und wobei das zweite Antriebsmittel (15, 21, 22, 24 & 27-29) umfaßt: einen Elektromotor (21), der eine Motorwelle aufweist, wobei der Motor (21) an dem Gehäuse (2) befestigt ist, eine auf der Motorwelle angebrachte Schnecke (22), ein erstes Schneckenrad (24), das in Eingriff mit der Schnecke

- (22) steht, eine zweite Schnecke (27), die koaxial zu dem ersten Schneckenrad (24) ist und damit verbunden ist, ein zweites Schneckenrad (28), das in Eingriff mit der zweiten Schnecke (27) steht, einen ersten Arm (30), der auf der zentralen Achse des zweiten Schneckenrads (28) so angebracht ist, daß bei Drehung dieser zentralen Achse der erste Arm (30) eine Schwenkbewegung ausführt; eine Auflageplatte (3) für die Kamera oder dergleichen, die über dem Gehäuse (2) angebracht ist, um eine Schwenkbewegung um eine zweite Achse auszuführen, die senkrecht zu der ersten Achse ist; und einen zweiten Arm (10), der sich von der Auflageplatte (3) in das Gehäuse (2) hinein erstreckt, wobei das achsferne Ende (14) des zweiten Arms (10) mit dem achsfernen Ende des ersten Arms (30) so verbunden ist, daß bei Betätigung des zweiten Antriebsmittels (15, 21, 22, 24 & 27-29) der zweite Arm (10), und folglich die Auflageplatte (3) sich um die zweite Achse dreht.
2. Schwenkkopf gemäß Anspruch 1, wobei jede Schnecke (22, 27, 46 oder 49) zu einem zugehörigen Schneckenrad (24, 28, 47 oder 42) hin vorgespannt ist.
 3. Schwenkkopf gemäß Anspruch 1 oder 2, wobei bei dem ersten Antriebsmittel (42, 44, 46, 47 & 49) eine Reibungskupplung (45) zwischen dem Gehäuse (2) und der Grundplatte (1) vorgesehen ist.
 4. Schwenkkopf gemäß Anspruch 3, wobei die Reibungskupplung (45) eine gewellte Unterlegscheibe aufweist, die zwischen einer ersten und einer zweiten Platte (43 & 41) unter Druckbelastung sandwichartig angeordnet ist, wobei die erste Platte (43) mit dem zweiten Schneckenrad (42) des ersten Antriebsmittels (42, 44, 46, 47 & 49), und die zweite Platte (41) mit der Grundplatte (1) verbunden ist, wobei die Anordnung eine manuelle Drehung der Grundplatte (1) relativ zu dem Gehäuse (2) ohne Drehung des zweiten Schneckenrades (42) zuläßt.
 5. Schwenkkopf gemäß Anspruch 1, bei dem der erste Arm (30) einen Stift (15) an seinem achsfernen Ende aufweist, und das achsferne Ende (14) des zweiten Arms (10) gabelförmig ist, wobei der Stift (15) in dem gabelförmigen Ende (14) des zweiten Arms (10) angeordnet ist, wodurch das zweite Schneckenrad (28) des zweiten Antriebsmittels (15, 21, 22, 24 & 27-

29) mit dem achsfernen Ende (14) des zweiten Arms (10) verbunden wird.

6. Schwenkkopf gemäß Anspruch 1, bei dem das erste Antriebsmittel (42, 44, 46, 47 & 49) auf einer Plattform (35) angebracht ist, die in dem Gehäuse (2) untergebracht ist und daran befestigt ist, wobei der Elektromotor (44) des ersten Antriebsmittels (42, 44, 46, 47 & 49) über der Plattform (35) angebracht ist, und die erste und zweite Schnecke (46 & 49) und das erste und zweite Schneckenrad (47 & 42) unter der Plattform (35) angebracht sind, und das zweite Antriebsmittel (15, 21, 22, 24 & 27-29) über der Plattform (35) angebracht ist.
7. Schwenkkopf gemäß Anspruch 1, wobei elektrische Kontakte (52) vorgesehen sind, um zu fühlen, wenn die Grundplatte (1) und das Gehäuse (2) vorgegebene relative Positionen erreichen.
8. Schwenkkopf gemäß Anspruch 1, der ein Fernsteuermittel aufweist, um jedes Antriebsmittel (42, 44, 46, 47 & 49, oder 15, 21, 22, 24 & 27-29) fernzusteuern.
9. Schwenkkopf gemäß Anspruch 1, der ein automatisches Steuermittel aufweist, um das erste Antriebsmittel (42, 44, 46, 47 & 49) und das zweite Antriebsmittel (15, 21, 22, 24 & 27-29) entsprechend einem vorgegebenen Programm zu steuern.

Revendications

1. Tête de rotation à commande électrique pour une caméra ou analogues, comprenant :
 une base (1);
 un logement (2) monté sur la base (1);
 des premier et second moyens d'entraînement (42, 44, 46, 47 & 49; 15, 21, 22, 24 & 27-29) entièrement contenus à l'intérieur du logement (2), le premier moyen d'entraînement (42, 44, 46, 47 & 49) comprenant : un moteur électrique (44) englobant un arbre de moteur, le moteur (44) étant fixe par rapport au logement (2), une vis sans fin (46) sur l'arbre de moteur, une première roue à vis (47) en engrènement avec la vis sans fin (46), une seconde vis sans fin (49) coaxiale à la première roue à vis (47) et reliée à cette dernière, une seconde roue à vis (42) en engrènement avec la seconde vis sans fin (49), la seconde roue à vis (42) étant reliée en entraînement à la base (1) de telle sorte que, lors de la mise en action du moteur (44), la base (1) tourne par rapport au logement (2) autour d'un premier axe, le se-

- cond moyen d'entraînement (15, 21, 22, 24 & 27-29) comprenant : un moteur électrique (21) englobant un arbre de moteur, le moteur (21) étant fixe par rapport au logement (2), une vis sans fin (22) sur l'arbre de moteur, une première roue à vis (24) en engrènement avec la vis sans fin (22), une seconde vis sans fin (27) coaxiale à la première roue à vis (24) et reliée à cette dernière, une seconde roue à vis (28) en engrènement avec la seconde vis sans fin (27), un premier bras (30) monté sur l'axe central de la seconde roue à vis (28) de telle sorte que la rotation de cette dernière provoque le mouvement oscillant du premier bras (30); un support (3) pour la caméra ou analogues, monté par-dessus le logement (2) pour pivoter autour d'un second axe perpendiculaire au premier axe; et
- un second bras (10) s'étendant à partir du support (3) jusque dans le logement (2), l'extrémité distale (14) du second bras (10) étant reliée en entraînement à l'extrémité distale du premier bras (30) de telle sorte que, lors de la mise en action du second moyen d'entraînement (15, 21, 22, 24 & 27-29), le second bras (10) et partant le support (3) tournent autour du second axe.
2. Tête de rotation selon la revendication 1, dans lequel chaque vis sans fin (22, 27, 46 ou 49) est mise en état de précontrainte en direction d'une roue respective à vis sans fin (24, 28, 47 ou 42).
 3. Tête de rotation selon la revendication 1 ou 2, dans lequel un embrayage à friction (45) est procuré dans le premier moyen d'entraînement (42, 44, 46, 47 & 49) entre le logement (2) et la base (1).
 4. Tête de rotation selon la revendication 3, dans lequel l'embrayage à friction (45) comprend une rondelle ondulée intercalée en compression entre une première et une seconde plaques (43 & 41), la première plaque (43) étant reliée en entraînement à la seconde roue à vis (42) du premier moyen d'entraînement (42, 44, 46, 47 & 49) et la seconde plaque (41) étant reliée en entraînement à la base (1), l'arrangement permettant la rotation manuelle de la base (1) par rapport au logement (2) sans rotation de la seconde roue à vis (42).
 5. Tête de rotation selon la revendication 1, dans lequel le premier bras (30) comporte une broche (15) sur son extrémité distale et l'extrémité distale (14) du second bras (10) est bifurquée, l'arrangement étant tel que la broche (15) vient

se disposer dans l'extrémité bifurquée (14) du second bras (10) pour ainsi relier en entraînement la seconde roue à vis (28) du second moyen d'entraînement (15, 21, 22, 24 & 27-29) à l'extrémité distale (14) du second bras (10).

6. Tête de rotation selon la revendication 1, dans lequel le premier moyen d'entraînement (42, 44, 46, 47 & 49) est monté sur une plate-forme (35) logée dans le logement (2) et fixée à ce dernier, le moteur électrique (44) du premier moyen d'entraînement (42, 44, 46, 47 & 49) étant monté par-dessus la plate-forme (35) et les première et seconde vis sans fin (46 & 49), ainsi que les première et seconde roues à vis (47 & 42) étant montées en dessous de la plate-forme (35), le second moyen d'entraînement (15, 21, 22, 24 & 27-29) étant monté par-dessus la plate-forme (35).
7. Tête de rotation selon la revendication 1, dans lequel des contacts électriques (52) détecteurs de position sont prévus pour détecter le moment auquel la base (1) et le logement (2) atteignent des positions relatives prédéterminées.
8. Tête de rotation selon la revendication 1, englobant un moyen de commande à distance pour commander à distance chaque moyen d'entraînement (42, 44, 46, 47 & 49 ou 15, 21, 22, 24 & 27-29).
9. Tête de rotation selon la revendication 1, englobant un moyen de commande automatique pour commander le premier moyen d'entraînement (42, 44, 46, 47 & 49) et le second moyen d'entraînement (15, 21, 22, 24 & 27-29) en fonction d'un programme préinstallé.

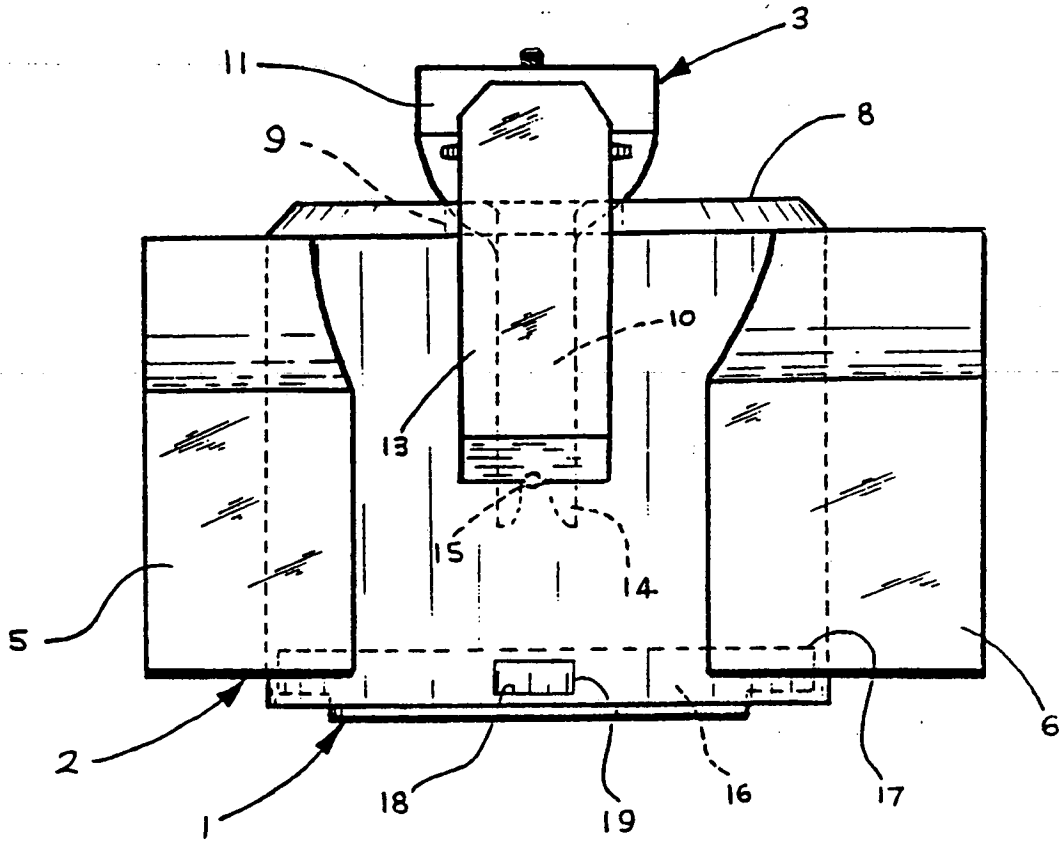

FIG. 1

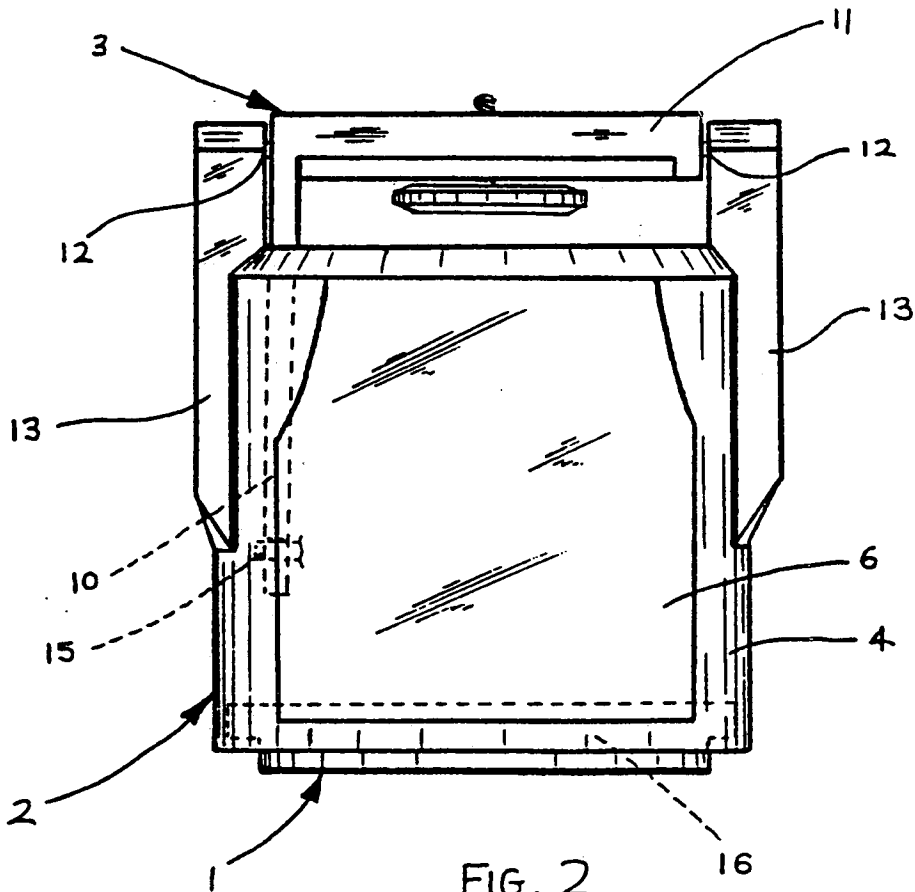

FIG. 2

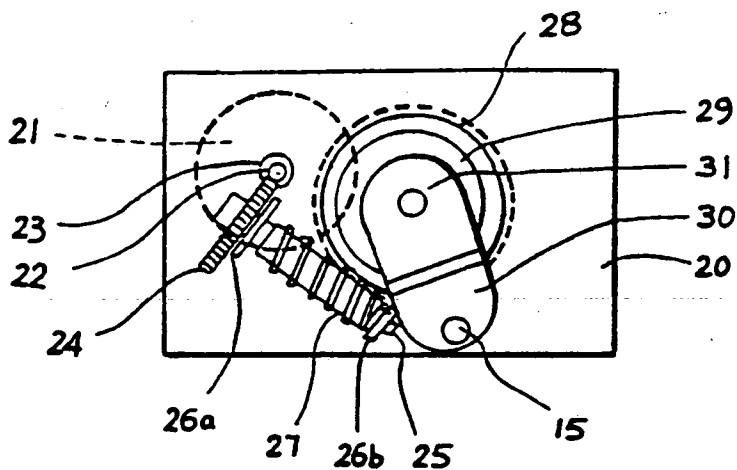

FIG. 3

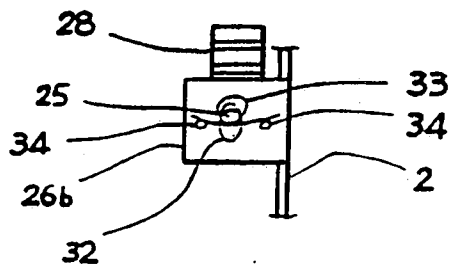

FIG. 3a

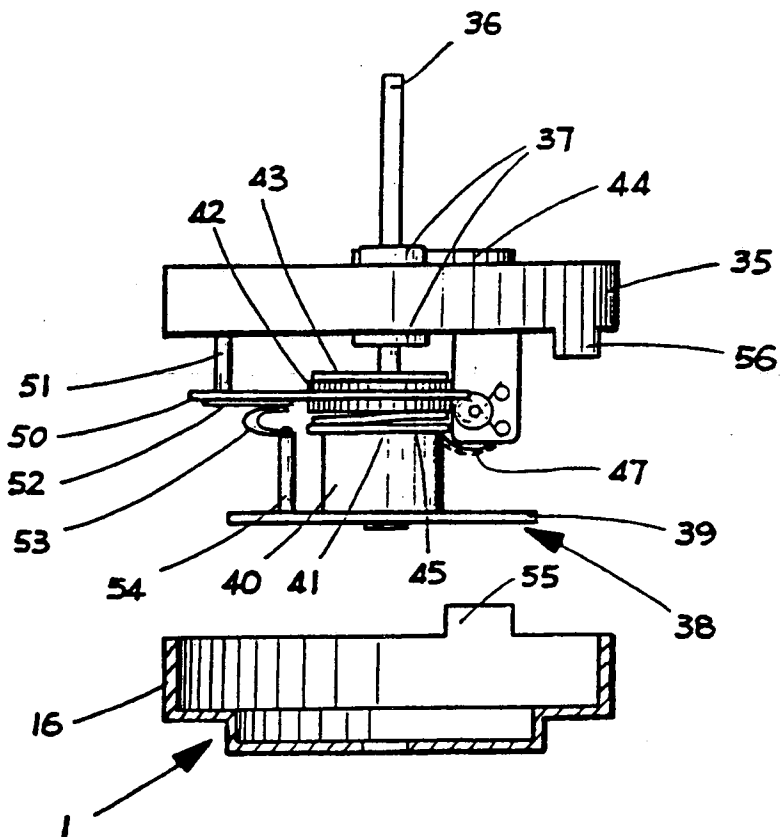
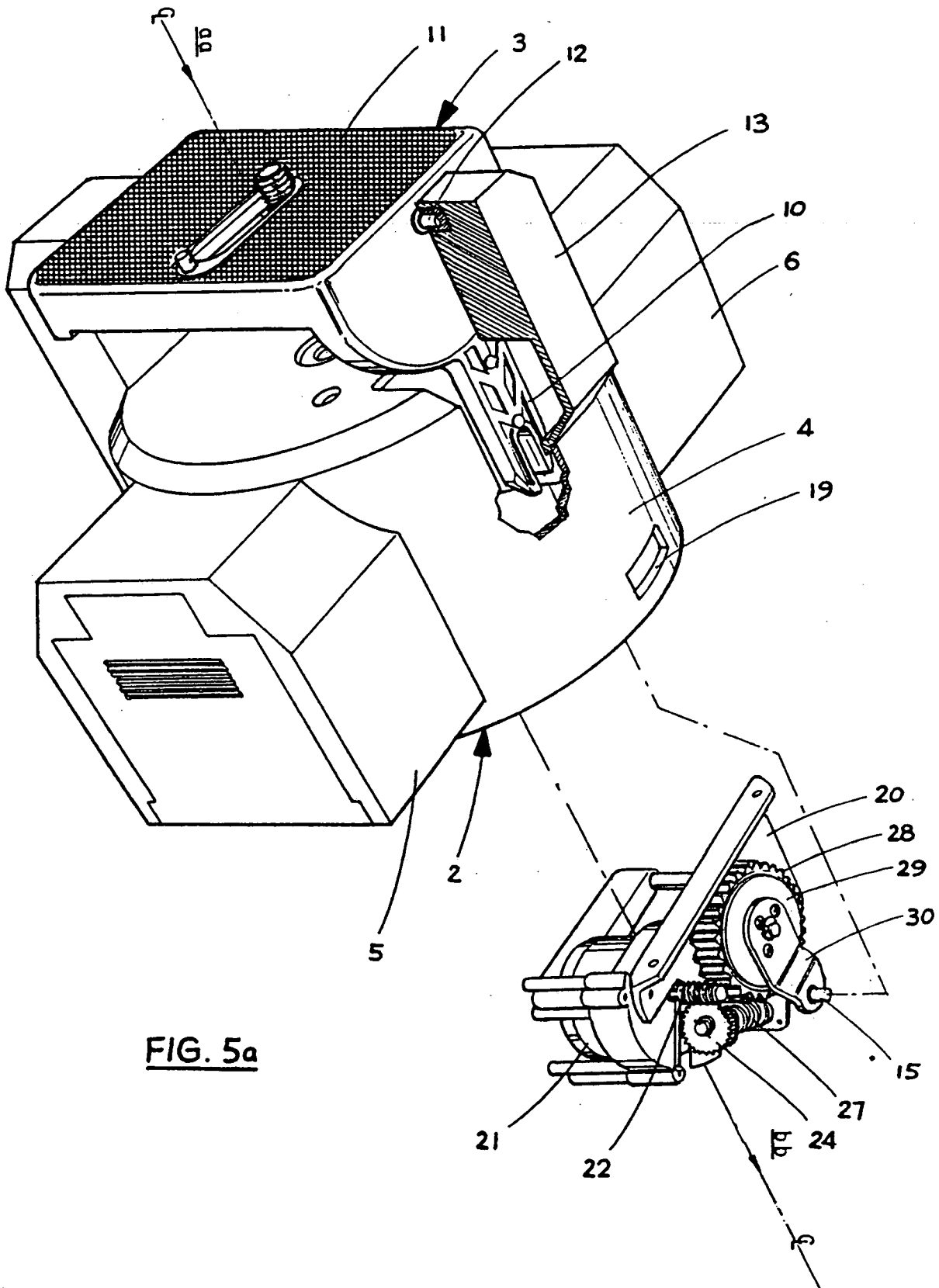

FIG. 4



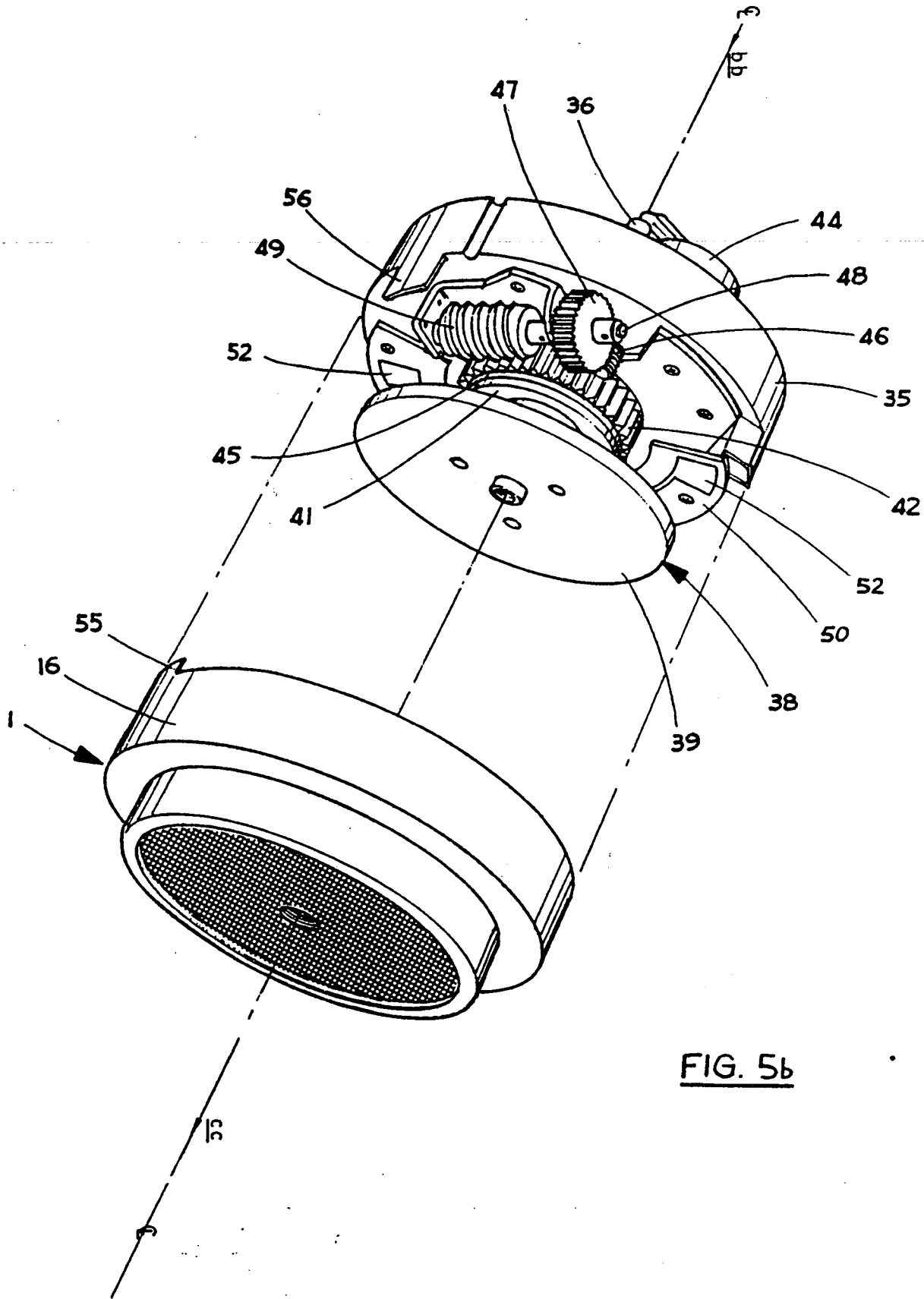

FIG. 5b

REGISTER ENTRY FOR EP0257988

European Application No EP87307375.3 filing date 20.08.1987

Priority claimed:

26.08.1986 in United Kingdom - doc: 8620625

Designated States BE CH DE ES FR GB GR IT LI LU NL SE AT

Title CAMERA PANNER

Applicant/Proprietor

MAXWELL ELECTRONICS LIMITED, Maxwell Industrial Building 350 Kwun Tong
Road, Kowloon, Hong Kong [ADP No. 50139955001]

Inventor

WILFRIED ALOIS ANTON BITTNER, Flat C2,12th Floor, Nam Hong Building, 23
Hong Lee Road, Kwun Tong, Kowloon, Hong Kong [ADP No. 55489397001]

Classified to

G2J
G03B

Address for Service

MICHAEL ROGER HIGGINS, MARKS & CLERK 57/60 Lincoln's Inn Fields, London
WC2A 3LS, United Kingdom [ADP No. 50546076001]

EPO Representative

MICHAEL ROGER HIGGINS, MARKS & CLERK 57/60 Lincoln's Inn Fields, London
WC2A 3LS, United Kingdom [ADP No. 50546076001]

Publication No EP0257988 dated 02.03.1988

Publication in English

Examination requested 20.08.1987

Patent Granted with effect from 03.03.1993 (Section 25(1)) with title CAMERA
PANNER.

30.09.1988 EPO: Search report published on 05.10.1988

Entry Type 25.11 Staff ID.

Auth ID. EPT

**** END OF REGISTER ENTRY ****

OA80-01
EP

OPTICS - PATENTS

27/06/94

16:13:39

PAGE: 1

RENEWAL DETAILS

PUBLICATION NUMBER

EP0257988

PROPRIETOR(S)

Maxwell Electronics Limited, Maxwell Industrial Building 350 Kwun
Tong Road, Kowloon, Hong Kong

DATE FILED

20.08.1987

DATE GRANTED

03.03.1993

DATE NEXT RENEWAL DUE

20.08.1994

DATE NOT IN FORCE

DATE OF LAST RENEWAL

16.08.1993

YEAR OF LAST RENEWAL

07

STATUS

PATENT IN FORCE