

1 562 288

- (21) Application No. 25074/76 (22) Filed 17 June 1976
 (23) Complete Specification filed 9 June 1977
 (44) Complete Specification published 12 March 1980
 (51) INT. CL.³ F16P 1/00
 (52) Index at acceptance
 F2J 1D2



(54) MILLING MACHINE GUARD

(71) I, DOUGLAS ERNEST ASLEN, a British subject, of 16 Pinfold Lane, Romiley, Cheshire, do hereby declare the invention, for which I pray that a Patent
 5 may be granted to me, and the method by which it is to be performed, to be particularly described in and by the following statement:—

The invention concerns milling machine
 10 guards, and has more particular reference to a guard intended to provide a barrier between a milling cutter and workpiece (or the relevant part thereof) on the one hand and a machine operator on the other.

15 It is known in the art to provide a milling machine guard which is mounted on the machine table and which moves with such table as the latter traverses relative to the milling tool. Whilst such known guard
 20 is adjustable according to the dimension of the workpiece in question, and has clear-view panels thereby to make visible the workpiece at least in the region of the cutting tool, the extent of adjustment is
 25 limited, and maximum adjustment in the direction of machine table movement is achieved at the expense of protection transversely of such direction of movement. Furthermore, the mounting of the guard on
 30 the table is often inconvenient in as much as this interferes with a proper location of the workpiece.

It is also known to provide a guard which is secured to the quill of the milling
 35 machine, such guard comprising a cylindrical or part-cylindrical skirt which extends downwardly from the quill about the periphery of the milling cutter. This type of guard has the obvious shortcoming that
 40 although there is protection against the operator coming into contact with the milling cutter, the material cut from the workpiece is in no sense confined. A guard secured to the dovetail of the overarm of
 45 the milling machine is also known.

The object of the present invention is to provide a guard for a milling machine, whether of the vertical or horizontal kind, which will preclude the operator from coming into contact with the milling cutter and
 50 which will also confine the material removed from the workpiece during the milling operation.

According to the present invention there is proposed a guard for a milling machine
 55 which includes a mounting bar adapted to be secured to a milling machine to extend transversely of the rotational axis of the milling cutter thereof, a mounting block on such mounting bar, a support rod extending
 60 from such block and having at least a part extending inclinedly with respect to the mounting bar, a support block movably mounted on such rod and adjustable axially
 65 thereof, and a guard panel supported by and adjustable relative to the said support block for movement in a direction generally perpendicular to the axes of the mounting bar and the support rod.

According to the present invention there
 70 is also proposed a guard for a milling machine comprising a mounting bar adapted to be secured to a milling machine to extend transversely of the rotational axis of the milling cutter thereof, a mounting
 75 block on such mounting bar, a pair of support rods extending from such block and each having at least a part extending inclinedly with respect to the mounting bar, a pair of support blocks each movably
 80 mounted on one of said support rods and adjustable axially thereof, and a pair of guard panels each supported by and adjustable relative to the one of the said support blocks for movement in a direction
 85 generally perpendicular to the axes of the mounting bar and its support rod.

According to a preferred feature, the or
 each guard panel is supported by and is
 90 adjustable relative to its support block via

a mounting rod slidably mounted in the support block and an attachment block slidably on the mounting rod and to which the said panel is attached.

5 According to a further preferred feature, the guard is secured to the milling machine via an attachment collar mountable on the quill of such milling machine, and the mounting bar extends radially outwardly
10 from such collar.

In one preferred arrangement, the guard includes four mounting bars arranged in equally spaced angular disposition about the axis of the attachment collar, there
15 being a mounting block, support block, support rod and guard panel on each such mounting bar.

The invention will now be described further, by way of example only, with reference to the accompanying drawing illustrating several embodiments and in
20 which:—

Fig. 1 is a diagrammatic plan view of a guard for a vertical milling machine constructed in accordance with the invention;
25

Fig. 2 is a diagrammatic perspective view, drawn to a larger scale, of a corner of the guard of the kind shown in Fig. 1;

Fig. 3 is a perspective view of a second
30 embodiment of the invention as applied to the context of a guard for a vertical milling machine; certain parts being omitted in the interests of clarity;

Fig. 4 is a perspective view, drawn to a
35 larger scale, of a part of the arrangement shown in Fig. 3;

Fig. 5 is a diagrammatic plan view of a third embodiment of the invention and shows the same in the context of a guard
40 for an horizontal milling machine; and

Fig. 6 is a diagrammatic perspective view of a part of the arrangement shown in Fig. 5.

Referring now to the drawings, and particularly to Figs. 1 and 2 thereof, a guard for a vertical milling machine comprises an attachment collar 11 releasably attachable to the quill of the milling machine, a plurality of mounting bars 12 extending
50 outwardly from the said collar 11 and arranged in angularly spaced disposition about the periphery thereof, a respective mounting block 13 slidably mounted on each mounting bar 12, two support rods 14
55 slidably engaged with each such mounting block 13 and extending outwardly from such block in respective and mutually inclined directions, a support block 16 slidably on each support rod 14, a respective
60 mounting rod 17 slidably engaged with each support block 16, and a respective attachment block 18 slidably mounted on each mounting rod 17, the said attachment blocks 18 being releasably secured to respective
65 guard panels 19 which collectively define a

depending skirt arranged about the milling cutter when the guard is applied to a milling machine.

The mounting bars 12 and support rods 14 are, in the use position of the guard, disposed generally horizontally, whilst the mounting rods 17 are arranged generally vertically.
70

The arrangement is illustrated in greater detail in Fig. 2, such figure showing a
75 corner region of the guard and it will be appreciated that the structure shown in Fig. 2 will be repeated at each of the other corners of the total structure. Thus, the collar 11 comprises upper and lower parts
80 11a, 11b arranged in spaced-apart, coaxial relationship, the upper part 11a being split and lugs 11c being provided at either side of the radial opening in such part to receive
85 a clamping bolt 21 for securing the collar 11 to the quill of the milling machine. The inner diameter of the lower part 11b of the collar exceeds that of the upper part 11a thereof so as freely to receive the quill, and the said upper and lower parts 11a, 11b
90 being connected together at a position diametrically opposite the radial opening in the upper such part.

The lower part 11b of the collar has radially directed through holes therein, each
95 to receive a respective one of the mounting bars 12, and a screw means (not shown) is provided in such lower part for abutment with a flat at the underside of the bar to secure such bar 12 relative to the collar
100 11.

The mounting block 13 is of hexagonal shape, when viewed in plan, two opposed faces 13a, 13b of such block lying at right angles to the axis of the mounting bar 12,
105 whilst the remaining faces 13c, 13d, 13e, 13f are inclined to such axis at an angle of 45° to lie parallel to the planes of the guard panels 19. Three through holes are provided in the mounting block in spaced
110 apart relationship in the vertical direction thereof, the axes of such holes being parallel to the planes of the top and bottom surfaces 13g, 13h of such block, one such hole extending between the two opposed faces
115 13a, 13b aforesaid and being intended to receive the mounting bar 12 into engagement therewith, and the other holes extend between face 13b and a non-adjacent one, 13d, 13e, of the inclined faces. Screw means
120 22, 23 are provided for abutment with the mounting bar 12 and support rods 14 to locate such elements in a requisite position relative to the mounting block 13.

Each support block 16 is generally rectangular and has a first through bore therein
125 to receive the support rod 14, and a second through bore to receive the mounting rod 17, the axes of the first and second through bores thus being mutually perpendicular.
130

Screw means 24,26 are provided for securing the block 16 in position on the support rod 14 and for securing the mounting rod 17 in a requisite axial position relative to the block 16, respectively.

The attachment block 18 has a single through bore therein to receive the lower end of the mounting rod 17, there being screw means 27 for securing such block 18 in position on the rod 17, and tapped holes are formed in one face of the block to receive screws 28 whereby the guard panel 19 is secured thereto.

The slidable mounting of the mounting block 13 on the mounting bar 12 will provide for the adjustment of the position of such block 13 radially of the rotational axis of the milling cutter as determined by the specific requirements of the situation.

Similarly, lateral adjustment of the guard panels 19 can be effected by movement of the support block 16 on the support rod 14, whilst vertical adjustment of such panels 19 requires a movement of the attachment block 18 axially of the mounting rod 17.

By means of the arrangement herein proposed we are able to adjust the form and dimensions of the guard to meet particular requirements within the limits imposed by the extent to which the panels overlap, or can be overlapped (see Fig. 1), and by the vertical dimensions of the panels, yet still maintain a substantially complete shield about the cutter.

An alternative to the arrangement shown in Figs. 1 and 2 is illustrated in Figs. 3 and 4, a slotted support frame being provided for attachment to the quill of the milling machine, and guard panels being adjustably supported relative to such frame. Thus, referring now to Figs. 3 and 4, the guard comprises a collar 31 for attachment to the milling machine quill (not shown), a plurality of mounting bars 32 extending radially from such collar in equi-spaced angular disposition thereabout, a respective mounting block 33 at the end of each mounting bar 32, and a respective slotted guide rail 34 on each block 33, the ends of the guide rails 34 being secured together to give a rigid support frame on which the guard panels 35 are mounted.

Each guide rail 34 consists of a flat bar arranged in a generally horizontal plane and secured at its mid-point to the upper face of the related mounting block 33, there being an elongate slot 36 in the rail 34 at each side of the said mounting block. A transverse entrance opening 37 is provided in respect of one elongate slot in each guide rail for a purpose hereafter to be made apparent.

In the embodiment illustrated, three guide rails 34 are shown, although the support frame may be formed by four such

rails to give a closed structure, and the ends of successive guide rails are arranged in overlying disposition and are secured together as by rivets or screws 38.

A respective support block arrangement 39 is provided in each elongate slot 36, the block arrangement 39 being adjustable longitudinally of the slot and having a through bore thereto for receiving a mounting rod 40 into free sliding engagement therewith, a locking means 41 being provided in the block arrangement for engagement with the rod 40 to secure the same in a requisite position axially of the rod.

The support block arrangement 39 comprises upper and lower generally cylindrical parts 39a,39b arranged in coaxial disposition and connectable together via complementarily screw-threaded parts thereon, there being a step 39c at the upper face of the lower part 39b for engagement with the slot 36, such step having flats 39c¹ thereon for engagement with the walls of the slot to secure the block arrangement against rotation relative thereto.

The locking means 41 comprises a locking screw 41a located in a radially directed, screw-threaded hole in the lower part 39b of the block arrangement 39, the screw having a handwheel 41b at its outer end and the inner end thereof abutting the mounting rod 40.

An attachment block 42 is secured to the lower end of the mounting rod 40, and the panel 35 is attached to such block 42 for adjustment therewith in the longitudinal direction of the rod.

A slot 35a is provided in the panel 35 in aligned, parallel disposition relative to the mounting rod 40, the slot being clearance on the shank of the locking screw 41a which extends therethrough and allowing of the adjustment of the panel in a vertical direction.

The entrance opening 37 is of such dimensions as to allow of the introduction of the support block arrangement into slot 36 through such opening, thereby permitting of the ready removal of a panel as and when desired.

As will readily be apparent, adjustment of the positions of the panels axially or radially of the milling tool can readily be effected by adjustment of the mounting rod 40 relative to the support block arrangement and by adjustment of such arrangement longitudinally of the slot 36, and thus the dimensions and disposition of the guard can be varied to suit particular requirements.

A milling machine guard constructed in accordance with the invention can be provided for use in the context of an horizontal milling machine, a typical such guard being shown in Figs. 5 and 6 of the drawings.

Referring now to Figs. 5 and 6, a guard for an horizontal milling machine comprises a plurality of mounting bars 51 extending transversely of the head of the machine at each side thereof, a mounting block 52 on each such mounting bar 51, a support rod 53 at each side of the machine head mounted in the blocks 52 at such side, and support blocks 54,54¹ on the said support rods 53 by which panels 55 are mounted relative to the milling tool.

Corresponding mounting bars 51 at the opposite sides of the machine head are arranged in axial alignment, and each is secured to a respective clamping block 56 engaged with one side of the dovetail guide 57 of the machine head, the opposed such clamping blocks 56 being secured together and clamped on the said guide 57 by a clamping bolt 58.

The support blocks 54,54¹ each receive a mounting rod 59 into engagement therewith and a respective attachment block 60 is provided on each rod 59 and is slidable thereon. A locking screw 61 secures the block 60 relative to the rod 59, such screw extending through the panel 55 and serving to attach such panel to the block.

Support block 54¹ includes a pivotal central portion 54^a with which the rod 59 is engaged, the said central portion 54^a being pivotal on support rod 53 and being angularly located thereon and relative to the fixed portion 54^b of the block 54¹ by ball catch means (not shown) between adjacent faces of the portions 54^a,54^b of the support block. As will be appreciated, the pivotal character of support block 54¹ will allow of the pivotal displacement of the panel 55 carried thereby, thus to provide for a ready access to the workpiece in the region of the milling cutter or to allow of a displacement of the panel in the event of an excessive build-up of swarf from the milling operation.

Conveniently, the guard panel 55¹ carried by support block 54¹ will be of angled form to provide a check at one or both sides thereof, such that, as the panel is pivoted upwardly from its initial use position, the guard will remain complete at the forward end of the machine head.

The invention is not limited to the exact features of the embodiments disclosed since alternatives will readily present themselves to one skilled in the art. Thus, for example, the guard is not limited to the rectangular configuration illustrated, since curved panels could be used to give a sensibly cylindrical guard, the support rods of such an arrangement conveniently being arcuate rather than straight.

In another arrangement, the mounting bar and related support rods are formed integrally, and the mounting block as illu-

strated is omitted, radially adjustment being provided for by using a two piece mounting bar, the forward end of which is of generally T-shape, and the two parts of which are connected together through a block 70 relative to which at least one of the two parts is axially adjustable.

In a modification of the arrangement shown in Figs. 1 and 2 of the drawings, the mounting bars extend outwardly from the collar so as to be perpendicular to the plane of the panel, and the mounting block has a support rod extending from each side thereof, there being respective support blocks, mounting rods and attachment blocks on each such support rod. In a development of this modification, the support rods and mounting rods are combined to form an element of inverted T-shape, such element being slidably engaged with the mounting block and an attachment block being slidable on each of the transverse limbs of the element.

WHAT I CLAIM IS:—

1. A guard for a milling machine comprising a mounting bar adapted to be secured to a milling machine to extend transversely of the rotational axis of the milling cutter thereof, a mounting block on such mounting bar, a support rod extending from such block and having at least a part extending inclinedly with respect to the mounting bar, a support block movably mounted on such rod and adjustable axially thereof, and a guard panel supported by and adjustable relative to the said support block for movement in a direction generally perpendicular to the axes of the mounting bar and the support rod.

2. A guard for a milling machine comprising a mounting bar adapted to be secured to a milling machine to extend transversely of the rotational axis of the milling cutter thereof, a mounting block on such mounting bar, a pair of support rods extending from such block and each having at least a part extending inclinedly with respect to the mounting bar, a pair of support blocks each movably mounted on one of said support rods and adjustable axially thereof, and a pair of guard panels each supported by and adjustable relative to the one of the said support blocks for movement in a direction generally perpendicular to the axes of the mounting bar and its support rod.

3. A guard as claimed in claim 1 or claim 2, wherein the or each guard panel is supported by and is adjustable relative to its support block via a mounting rod slidably mounted in the support block and an attachment block slidable on the mounting rod and to which the said panel is attached.

4. A guard as claimed in any one of claims 1, 2 or 3, wherein the guard is secured to the milling machine via an attachment collar mountable on the quill of such milling machine, and the mounting bar extends radially outwardly from such collar.
5. A guard as claimed in any one of the preceding claims, wherein the or each support rod comprises a slotted bar.
6. A guard as claimed in claim 5, wherein the or each support rod extends at opposing sides of the mounting block.
7. A guard as claimed in claim 6, wherein an entrance opening is provided in the bar to provide access to the slot therein.
8. A guard as claimed in any one of claims 5 to 7, wherein the or each support block is engaged with a respective slot in its support rod.
9. A guard as claimed in claim 8, wherein the support block is non-rotatably mounted in said slot.
10. A guard as claimed in claim 8 or 9, wherein the or each support block comprises two complementary members arranged at opposite sides of its support rod and engaged with the slot therein, the complementary members being secured together to clamp the support rod therebetween.
11. A guard as claimed in any one of claims 8 to 10, wherein a mounting rod is engaged with the or each support block and is slidable relative thereto, locking means being provided for locating the or each mounting rod axially relative to its support block.
12. A guard as claimed in claim 11, wherein an attachment block is provided on the or each mounting rod and in fixed disposition relative thereto, the or each panel being secured to one such attachment block.
13. A guard as claimed in claim 12, wherein a slot is provided in the or each panel, the securing means including a screw extending outwardly of the support block through the slot and the panel being movable relative to such locking means within limits imposed by the slot.
14. A guard as claimed in any one of claims 1, 2 or 3, wherein clamping blocks are provided from each of which a mounting bar extends the blocks being adapted for engagement with the dovetail guide of an horizontal milling machine.
15. A guard as claimed in any one of claims 1, 2, 3 and 14, wherein the or each support block includes a support block having a pivotally mounted part whereby the panel associated therewith is pivotal from its initial operative position.
16. A guard as claimed in claim 15, wherein ball-catch means are provided for locating the movable panel in an initial operative position.
17. A guard as claimed in claim 15 or 16, wherein the pivotal panel has a side cheek or cheeks thereto thus to maintain the integrity of the guard when such panel is pivoted away from its initial operative position.
18. A milling machine guard substantially as hereinbefore described, with reference to and as illustrated in Figs. 1 and 2, Figs. 3 and 4, or Figs. 5 and 6 of the accompanying drawings.

Agents for the Applicant,
 SYDNEY E. M'CAW & CO.,
 Chartered Patent Agents,
 Saxone House,
 52-56 Market Street,
 Manchester M1 1PP.

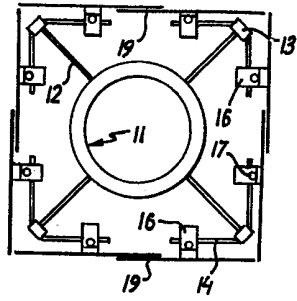

FIG. 1

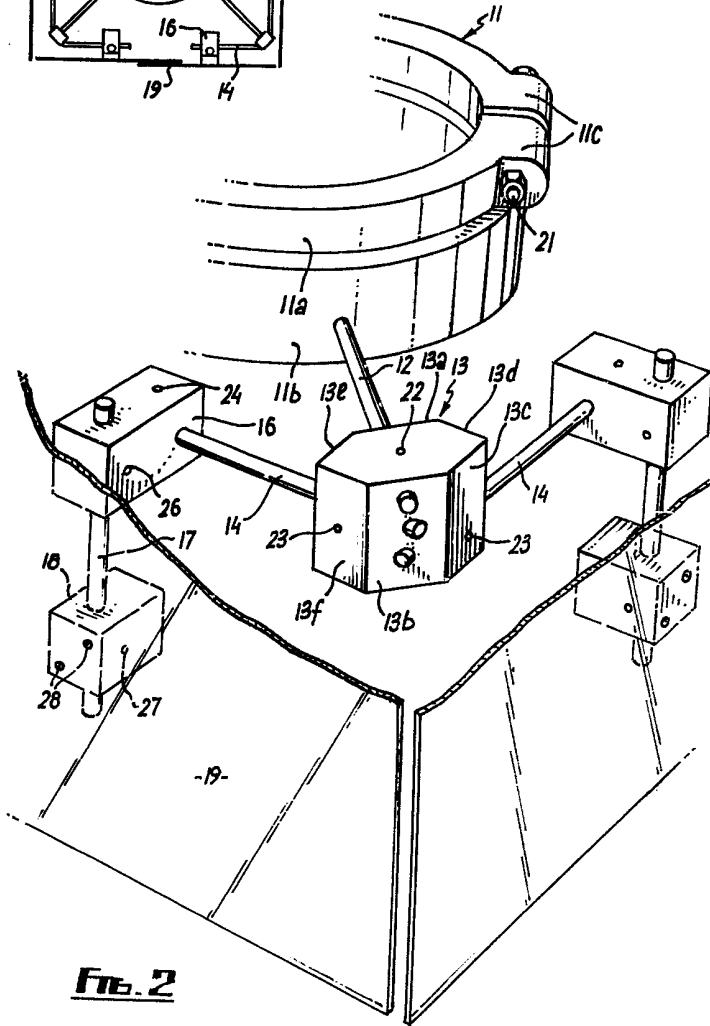

FIG. 2

1562288

COMPLETE SPECIFICATION

4 SHEETS

This drawing is a reproduction of
the Original on a reduced scale
Sheet 2

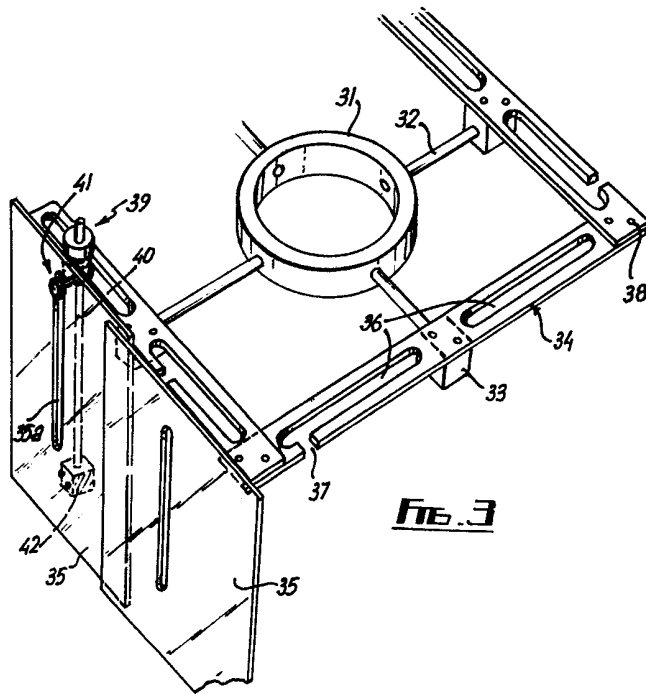

FIG. 3

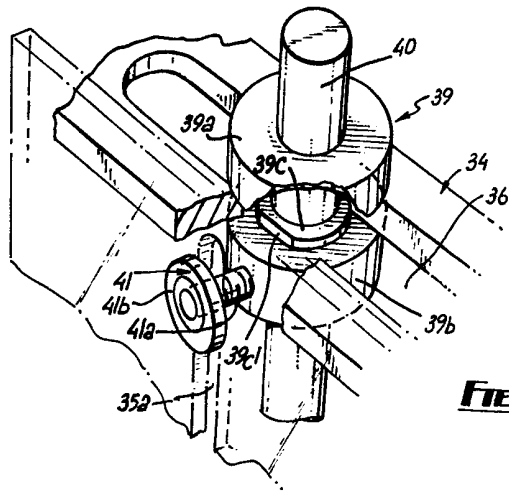

FIG. 4

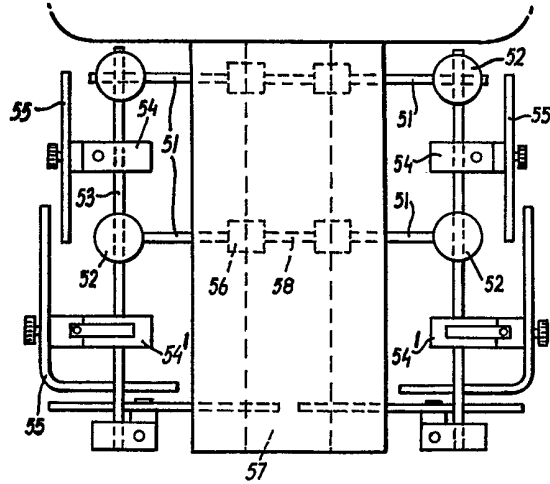

FIG. 5

