



(12) **DEMANDE DE BREVET CANADIEN  
CANADIAN PATENT APPLICATION**

(13) **A1**

(86) Date de dépôt PCT/PCT Filing Date: 2020/07/15  
 (87) Date publication PCT/PCT Publication Date: 2021/01/21  
 (85) Entrée phase nationale/National Entry: 2022/01/13  
 (86) N° demande PCT/PCT Application No.: US 2020/042145  
 (87) N° publication PCT/PCT Publication No.: 2021/011659  
 (30) Priorité/Priority: 2019/07/15 (US62/874,279)

(51) Cl.Int./Int.Cl. *A61B 17/32* (2006.01),  
*A61B 17/00* (2006.01), *A61B 17/04* (2006.01),  
*A61B 17/10* (2006.01)  
 (71) Demandeur/Applicant:  
ANCORA HEART, INC., US  
 (72) Inventeurs/Inventors:  
SAMPSON, RUSSEL, US;  
BARON, DAVID SCOTT, US;  
KOTMEL, ROB, US  
 (74) Agent: BORDEN LADNER GERVAIS LLP

(54) Titre : DISPOSITIFS ET PROCÉDES DESTINÉS A LA COUPE D'ATTACHE  
 (54) Title: DEVICES AND METHODS FOR TETHER CUTTING

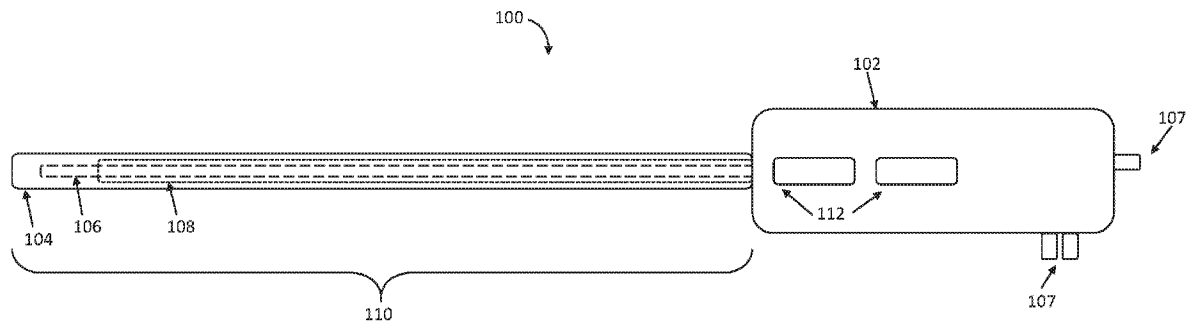

FIG. 1A

(57) **Abrégé/Abstract:**

Devices and methods for cutting a tether are described herein. Devices described herein generally comprise a proximal handle, a catheter, and an inner shaft and a cutting blade disposed within the lumen of the catheter, where the cutting blade is movably disposed over the inner shaft. The proximal handle comprises an actuation mechanism to control the movement of the components of the device. Methods described herein generally comprise advancing a tether-cutting device over a tether, loading the tether through the catheter and inner shaft, applying tension to the tether, and rotating and distally translating a cutting blade in order to cut the tether.

## (12) INTERNATIONAL APPLICATION PUBLISHED UNDER THE PATENT COOPERATION TREATY (PCT)

(19) World Intellectual Property  
Organization  
International Bureau



(10) International Publication Number  
**WO 2021/011659 A1**

(43) International Publication Date  
21 January 2021 (21.01.2021)

## (51) International Patent Classification:

*A61B 17/32* (2006.01)      *A61B 17/04* (2006.01)  
*A61B 17/00* (2006.01)      *A61B 17/10* (2006.01)

## (21) International Application Number:

PCT/US2020/042145

## (22) International Filing Date:

15 July 2020 (15.07.2020)

## (25) Filing Language:

English

## (26) Publication Language:

English

## (30) Priority Data:

62/874,279      15 July 2019 (15.07.2019)      US

(71) Applicant: **ANCORA HEART, INC.** [US/US]; 2355  
Calle de Luna, Santa Clara, California 95054 (US).

(72) Inventors: **SAMPSON, Russel**; c/o Ancora Heart, Inc.,  
2355 Calle de Luna, Santa Clara, California 95054 (US).  
**BARON, David Scott**; 1229 Manzano Way, Sunnyvale,  
California 94089 (US). **KOTMEL, Rob**; 116 Bloomfield  
Road, Burlingame, California 94010 (US).

(74) Agent: **MAYER, Mika R.** et al.; 1299 Pennsylvania Av-  
enue NW, Suite 700, Washington, District of Columbia  
20004-2400 (US).

(81) Designated States (*unless otherwise indicated, for every  
kind of national protection available*): AE, AG, AL, AM,  
AO, AT, AU, AZ, BA, BB, BG, BH, BN, BR, BW, BY, BZ,  
CA, CH, CL, CN, CO, CR, CU, CZ, DE, DJ, DK, DM, DO,  
DZ, EC, EE, EG, ES, FI, GB, GD, GE, GH, GM, GT, HN,

HR, HU, ID, IL, IN, IR, IS, IT, JO, JP, KE, KG, KH, KN,  
KP, KR, KW, KZ, LA, LC, LK, LR, LS, LU, LY, MA, MD,  
ME, MG, MK, MN, MW, MX, MY, MZ, NA, NG, NI, NO,  
NZ, OM, PA, PE, PG, PH, PL, PT, QA, RO, RS, RU, RW,  
SA, SC, SD, SE, SG, SK, SL, ST, SV, SY, TH, TJ, TM, TN,  
TR, TT, TZ, UA, UG, US, UZ, VC, VN, WS, ZA, ZM, ZW.

(84) Designated States (*unless otherwise indicated, for every  
kind of regional protection available*): ARIPO (BW, GH,

GM, KE, LR, LS, MW, MZ, NA, RW, SD, SL, ST, SZ, TZ,  
UG, ZM, ZW), Eurasian (AM, AZ, BY, KG, KZ, RU, TJ,  
TM), European (AL, AT, BE, BG, CH, CY, CZ, DE, DK,  
EE, ES, FI, FR, GB, GR, HR, HU, IE, IS, IT, LT, LU, LV,  
MC, MK, MT, NL, NO, PL, PT, RO, RS, SE, SI, SK, SM,  
TR), OAPI (BF, BJ, CF, CG, CI, CM, GA, GN, GQ, GW,  
KM, ML, MR, NE, SN, TD, TG).

## Declarations under Rule 4.17:

— *as to applicant's entitlement to apply for and be granted a  
patent (Rule 4.17(ii))*

## Published:

— *with international search report (Art. 21(3))*

## (54) Title: DEVICES AND METHODS FOR TETHER CUTTING

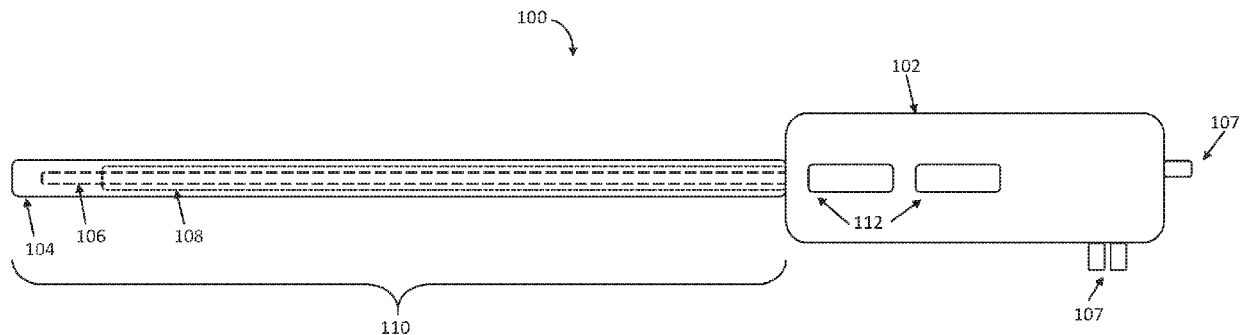

FIG. 1A

(57) Abstract: Devices and methods for cutting a tether are described herein. Devices described herein generally comprise a proximal handle, a catheter, and an inner shaft and a cutting blade disposed within the lumen of the catheter, where the cutting blade is movably disposed over the inner shaft. The proximal handle comprises an actuation mechanism to control the movement of the components of the device. Methods described herein generally comprise advancing a tether-cutting device over a tether, loading the tether through the catheter and inner shaft, applying tension to the tether, and rotating and distally translating a cutting blade in order to cut the tether.



WO 2021/011659 A1

## DEVICES AND METHODS FOR TETHER CUTTING

### CROSS-REFERENCE TO RELATED APPLICATIONS

**[0001]** This application claims priority to U.S. Provisional Patent Application No. 62/874,279 filed July 15, 2019, which is hereby incorporated by reference in its entirety.

### TECHNICAL FIELD

**[0002]** The devices and methods described herein relate generally to termination of tethers that have been deployed to a target site in a body of a subject. More specifically, the devices and methods described herein related to cutting such tethers after they have been secured.

### BACKGROUND

**[0003]** Many types of medical procedures involve the use of tethers. For example, a tether may be used to bring together two or more tissue regions. The tether may then be secured to maintain the compression or tension applied to the tissue region by the tether, and extra tether may be cut or removed. However, consistently cutting a tether can be difficult, as the tether often needs to be cut at or near the target site in the body of the subject and tethers used to secure tissue are generally very strong. Current devices and methods of cutting a tether are often unreliable and may fail to fully cut the tether, or may prematurely cut the tether before the device is positioned. Further, certain devices or methods may cut the tether at more than one point, resulting in the formation of loose pieces of tether.

**[0004]** Accordingly, it would be desirable to provide devices that can be placed simply and effectively at a target site, and methods for effectively cutting a tether after the tether has been deployed at the target site and secured. It would further be desirable for such methods and devices to be efficient and reliable, and to have a way of protecting the tether from being cut until the operator is ready. Further, it would be desirable for devices and methods to cut the tether in only one place to avoid the need for an additional step of retrieving loose pieces of tether.

## SUMMARY

**[0005]** Described herein are devices and methods for cutting a tether, such as a tether that has been used to tighten or compress tissue (e.g., by pulling two or more sections or pieces of tissue together). Devices described herein generally include a catheter, an inner shaft, and a cutting blade. The inner shaft may be coaxial with the cutting blade, and both the inner shaft and cutting blade may be coaxially arranged within the catheter lumen. For example, the inner shaft may be disposed within the lumen of the catheter, and the cutting blade may be disposed over the inner shaft. The catheter may comprise a proximal end, a distal end, a lumen therethrough, and a sidewall, where the sidewall comprises a first opening and a second opening distal to the first opening. The lumen of the catheter may terminate in a distal opening. The inner shaft may comprise a proximal end, a distal end, and a shaft lumen therethrough, where the inner shaft is disposed within the lumen of the catheter proximal to the first opening. The cutting blade may be disposed over the inner shaft, and an actuation mechanism may be coupled to the cutting blade and configured to rotate and translate the cutting blade about the inner shaft.

**[0006]** In some variations, the inner shaft may be stationary within the lumen of the catheter. In other variations, the inner shaft may be moveable within the lumen of the catheter. A lead screw may be coupled to the inner shaft, where rotation of the lead screw translates the inner shaft. An actuation mechanism may be coupled to the lead screw, such that moving the actuation mechanism turns the lead screw. In some variations, a gear mechanism may be coupled to the inner shaft, where rotation of the gear rotates and/or translates the inner shaft. In some variations, the distal end of the inner shaft may be blunt.

**[0007]** Tether-cutting devices described herein may further comprise a first configuration where a distal end of the blade is proximal to the distal end of the inner shaft, and a second configuration where the distal end of the blade is distal to the distal end of the inner shaft. Devices may comprise an actuation mechanism configured to move the blade between the first and second configurations in order to cut a tether. In some variations, a tether may extend across a portion of the catheter lumen into the lumen of the inner shaft. For example, a tether extending from the second opening, through the first opening, and through the shaft lumen, may extend partially across the lumen of the catheter. The cutting blade may be

rotatable and longitudinally translatable over the inner shaft in order to cut the tether. In some variations, the blade may be tubular.

**[0008]** Tether-cutting devices described herein may further comprise a proximal handle. The proximal handle may comprise an actuation mechanism to move the blade between the first and second configurations, for example. The actuation mechanism may comprise a lead screw coupled to the blade, where rotation of the screw rotates and longitudinally translates the blade. For example, the actuation mechanism may be configured to simultaneously slide the blade along the length of the catheter, and rotate the blade about a longitudinal axis of the catheter. In some variations, the actuation mechanism may be configured to bidirectionally move the blade distally and proximally within the catheter. In some variations, the blade may be retained within the lumen of the catheter by the actuation mechanism.

**[0009]** Also described herein are methods of cutting a tether. Methods may comprise advancing a tether-cutting device over a tether, applying tension to the tether, and simultaneously rotating and distally translating a cutting blade of the tether-cutting device to cut a portion of the tether that extends partially across a lumen of a catheter of the tether-cutting device. In some variations, advancing a tether-cutting device over a tether may also include loading the tether into the various components of the device. The tether-cutting device advanced over the tether may comprise a catheter, an inner shaft, and a cutting blade disposed over the inner shaft. The catheter may comprise a lumen and a sidewall, where the sidewall may comprise a first opening, and a second opening distal to the first opening. The inner shaft may comprise a shaft lumen, and the inner shaft may be disposed within the lumen of the catheter. The device may further comprise a cutting blade disposed over the inner shaft. In some variations, the blade and the inner shaft may be coaxial. In some variations, a tether may extend from the second opening, through the first opening, and through the shaft lumen such that a portion of the tether extends partially across the lumen of the catheter. In some variations, simultaneously rotating and distally translating the blade comprises actuating an actuation mechanism coupled to the cutting blade. The actuation mechanism may be in a proximal handle. Rotating and distally translating the blade may comprise moving the blade from the first position to the second position.

**[0010]** Methods described herein may further comprise proximally translating the blade. In some variations, methods of cutting a tether may further comprise actuating the blade to

move from a first position in which a distal end of the blade is proximal to a distal end of the inner shaft, to a second position in which the distal end of the blade is distal to the distal end of the inner shaft. In some variations, the blade may remain in a first position until actuated using the actuation mechanism. Methods may also comprise adjusting an angle of the tether prior to cutting the tether. A length of a tether that extends from the first opening into the shaft lumen forms an angle with respect to a longitudinal axis of the shaft lumen. Methods may comprise adjusting the angle to a first pre-selected angle value prior to advancing the tether-cutting device over the tether, and adjusting the angle to a second pre-selected angle value prior to cutting the tether. In some variations, the second pre-selected angle value may be greater than the first pre-selected angle value. Adjusting the angle to the first pre-selected angle value may comprise proximally translating the inner shaft. Adjusting the angle to the second pre-selected angle value may comprise distally translating the inner shaft. In some variations of methods described herein, the tether is a component of a heart implant that has been secured in a heart at an implant site, and the method of cutting a tether may further comprise advancing the tether-cutting device to the implant site. The implant may be a valve repair device comprising anchors affixed to tissue and coupled to a tether

#### BRIEF DESCRIPTION OF THE DRAWINGS

**[0011]** The drawings primarily are for illustrative purposes and are not intended to limit the scope of the inventive subject matter described herein. The drawings are not necessarily to scale; in some instances, various aspects of the inventive subject matter disclosed herein may be shown exaggerated or enlarged in the drawings to facilitate an understanding of different features. In the drawings, like reference characters generally refer to like features (e.g., functionally similar and/or structurally similar elements).

**[0012]** FIGS. 1A and 1B depict schematic representations of one variation of a tether-cutting device;

**[0013]** FIGS. 2A and 2B depict one variation of a tether-cutting device;

**[0014]** FIGS. 3A and 3B depict schematic side cross-sectional views of a variation of a tether-cutting device;

[0015] FIG. 3C depicts a schematic front cross sectional view of a variation of a tether-cutting device taken along line 3C-3C of FIG. 3A;

[0016] FIGS. 4A-4C depict perspective views of the components of one variation of a tether-cutting device;

[0017] FIG. 5A depicts a perspective view of a proximal handle of a tether-cutting device;

[0018] FIGS. 5B and 5C depict side partial cutaway views of the components of one variation of a tether-cutting device;

[0019] FIGS. 5D-5G depict perspective views of the components of one variation of a tether-cutting device;

[0020] FIG. 6 depicts a flowchart representation of one variation of a method for cutting a tether.

#### DETAILED DESCRIPTION

[0021] The following description is not intended to limit the devices and methods described herein to these variations. Variations, configurations, implementations, example implementations, and examples described herein are optional and are not exclusive to the variations, configurations, implementations, exemplified implementations, and examples they described. The devices and methods described herein can include any and all permutations of these variations, configurations, implementations, example implementations, and examples.

[0022] Described herein are devices and methods for cutting a tether. One variation of a tether-cutting device may comprise a catheter, an inner shaft, and a cutting blade. The inner shaft and the cutting blade may be coaxially arranged within the catheter lumen. The cutting blade may be movably disposed about the inner shaft (e.g., longitudinally translatable and/or rotatable over the inner shaft). The inner shaft may comprise a longitudinal lumen and may extend from a distal portion of the catheter to a proximal handle. In some variations, a tether may be extended across a portion of the catheter lumen into the lumen of the inner shaft. For example, the tether may extend from an opening in the sidewall of the catheter into the lumen of the inner shaft, and extend through the length of the inner shaft lumen to the proximal handle. The inner shaft may shield the tether from the cutting blade while the device is

advanced over the tether to the desired cut location. The cutting blade may be rotatable and longitudinally translatable over the inner shaft in order to contact and cut the tether. Simultaneous translation and rotation of the cutting blade may create a shearing or slicing effect on the tether, which may help facilitate consistent and reliable cutting of the tether. In some variations, the proximal handle of a tether-cutting device may be coupled to the proximal ends of the catheter, inner shaft and cutting blade.

**[0023]** One variation of a method for cutting a tether may comprise threading a tether through a tether-cutting device such that the tether extends from an opening in the sidewall of a catheter into a lumen of an inner shaft disposed within the catheter lumen, and simultaneously rotating and translating a cutting blade disposed over the inner shaft to contact and cut the portion of the tether extending between the sidewall opening and the inner shaft lumen. In some variations, the method may comprise advancing a tether-cutting device over a tether, and holding the tether in tension prior to cutting the tether. Optionally, in some variations, the inner shaft may be moved proximally within the catheter lumen, which may help reduce the catheter tracking force and facilitate the advancement of the catheter. The method may further comprise using an actuation mechanism to control the translation and rotation of the cutting blade to cut the tether. Simultaneous translation and rotation of the cutting blade may allow the cutting blade to apply a shearing force to slice through the tether, which may facilitate reliable cutting of the tether. The cutting blade may be translated such that it moves from a first position, in which a distal end of the cutting blade is proximal to a distal end of the inner shaft, to a second position, in which a distal end of the cutting blade (e.g. a sharpened edge) is distal to a distal end of the inner shaft. Optionally, in some variations, the inner shaft may be advanced distally (e.g., closer, but preferably not distal to, the proximal-most opening in the sidewall of the catheter) which may provide a more effective cutting angle between the tether and the cutting blade just prior to translating the cutting blade to contact the tether.

## **DEVICES**

**[0024]** Tether-cutting devices described herein generally comprise a proximal handle attached to a catheter assembly comprising a catheter, an inner shaft and a cutting blade. The inner shaft and the cutting blade may be disposed coaxially within the lumen of the catheter. The proximal handle may comprise one or more actuation mechanisms configured to control

the movement of the various components of the device, such as the cutting blade and/or the inner shaft. The cutting blade may be movably disposed over the inner shaft within the lumen of the catheter. The actuation mechanism may allow to operator to simultaneously rotate and translate the cutting blade about the inner shaft. The inner shaft may be configured to protect the tether from being cut by the catheter. When the cutting blade is in a first position in which a sharpened portion of the cutting blade is proximal to a distal end of the inner shaft, the inner shaft may retain the tether distal to the sharpened portion so that the tether is not cut. In order to cut the tether, the operator may actuate the cutting blade to move the cutting blade to a second position in which the sharpened portion of the cutting blade is distal to the distal end of the inner shaft. As the cutting blade is moved from the first position to the second position, the cutting blade may come into contact with and cut the tether.

**[0025]** FIG. 1A depicts a schematic view of one variation of a tether-cutting device (100). The tether-cutting device (100) may comprise a proximal handle (102), attached to a catheter assembly (110) comprising a catheter (104), an inner shaft (106), and a cutting blade (108). The cutting blade (108) and the inner shaft (106) are disposed coaxially within the lumen of the catheter (104). A tether may extend across a portion of the catheter lumen, for example, from an opening in sidewall of the catheter (104) into a lumen of the inner shaft (106). In some variations, the tether may be held in tension outside of the proximal handle, which may help facilitate cutting the tether. The proximal handle (102) may comprise one or more actuation mechanisms (112) to control the various components of the device, for example, movement of the cutting blade (108) within the catheter lumen. For example, an actuation mechanism may be coupled to the cutting blade (108) and configured to move it from its first position in the first configuration to its second position in the second configuration. In some variations, a safety tab may be coupled to the actuation mechanism (112) to prevent the actuation mechanism from being moved, and/or to prevent movement of the cutting blade until the operator is ready to cut the tether. By holding the cutting blade stationary in the lumen of the catheter until the tether is ready to be cut, the safety tab helps protect the tether from being prematurely cut. Optionally, the proximal handle may comprise additional actuation mechanisms (112) that are configured to control movement of the inner shaft (106) within the catheter lumen. The proximal handle (102) may further comprise various ports (107) to allow for exit and entry of various devices and/or substances through the catheter. For example, the proximal handle may comprise a port through which the tether may be

threaded to exit the catheter at the proximal end. The proximal handle may also include various flush ports that allow the operator to introduce fluids, such as saline solution, into various components of the device. For example, the proximal handle may comprise ports to deliver fluids into the lumen of the catheter, the inner shaft, and/or the cutting blade. Any of the ports described above may allow for introduction of fluids (e.g. saline solution, contrast agents, medicaments), and/or the introduction of devices (e.g. implant delivery devices, catheters, imaging devices) into the lumen of any or all of the components of the catheter assembly.

**[0026]** FIG. 1B is a schematic depiction of one example of a tether threaded through a tether-cutting device. As depicted there, the tether-cutting device may comprise a catheter (106) having a proximal end, a distal end, a catheter lumen (132) and an opening (151) in its sidewall, an inner shaft (106) and a cutting blade (108) that is disposed over the inner shaft (106). The catheter lumen (132) may extend between the proximal and distal ends. The inner shaft (106) may comprise a proximal end, a distal end and an inner shaft lumen (144) that extends between the proximal and distal ends. The cutting blade (108) may comprise a proximal end, a distal end and a cutting blade lumen (109) that extends between the proximal and distal ends. The cutting blade (108) may be slidably disposed about the inner shaft (106). The inner shaft (106) may be disposed within the cutting blade lumen (109), and the cutting blade (108) may be disposed within the catheter lumen (132) such that the catheter, the inner shaft, and the cutting blade are oriented coaxially. That is, the central longitudinal axes of each of the catheter, the inner shaft, and the cutting blade are substantially aligned with each other. In some variations, the catheter may comprise two or more sidewall openings. A tether (118) may extend across a portion of the catheter lumen (132) between the sidewall opening (151) and the inner shaft lumen (144). The tether (118) may extend through the entire length of the inner shaft lumen to the proximal handle (not shown in FIG. 1B). The cutting blade may be rotatable and longitudinally translatable over the inner shaft in order to contact and cut the tether.

**[0027]** The tether-cutting device may comprise a first configuration and a second configuration. In the first configuration, the cutting blade may be retained in a location that is proximal to a distal end of the inner shaft. For example, as depicted in FIG. 1B, the sharpened portion of the cutting blade (e.g., the distal-most end), is located proximal to the distal end of

the inner shaft (106). In this first configuration, the sharpened portion of the cutting blade does not contact and/or cut the portion of the tether (118) that extends between the inner shaft lumen (144) and the sidewall opening (151). This may help reduce the risk of unintentionally cutting the tether, for example, while the tether-cutting device is being advanced over the tether to the desired cut position. In the second configuration, the cutting blade (108) may be located distal to the distal end of the inner shaft (106). As the cutting blade (108) translates distally from a first location in the first configuration (i.e., a location that is proximal to the distal end of the inner shaft) to a second location in the second configuration (i.e., a location that is distal to the distal end of the inner shaft), it may contact and cut the tether (118). That is, as the cutting blade (108) moves distally, it may contact and cut the portion of the tether (118) that extends between the sidewall opening (151) and the inner shaft lumen (144). In some variations, the cutting blade (108) may be simultaneously rotated and distally translated as the device transitions from the first configuration to the second configuration. Rotating and longitudinally translating the cutting blade may provide a shear force that facilitates reliable and complete cutting of the tether.

**[0028]** While the variation of the tether-cutting device depicted in FIG. 1B has one sidewall opening in the catheter, optionally, in some variations, the catheter may further comprise an opening at a distal end, and a second sidewall opening. The second sidewall opening may be distal to the first sidewall opening. In some variations, the tether may be threaded into the catheter lumen through the distal opening, out of the catheter lumen through the second sidewall opening, and back into the catheter lumen through the first sidewall opening. The tether may then be threaded from the first sidewall opening and into the lumen of the inner shaft such that it crosses a portion of the catheter lumen, as described above. The tether may then extend proximally along the entire length of the inner shaft to the proximal handle of the tether-cutting device and may exit the handle at a tether port.

**[0029]** FIGS. 2A and 2B depict an exemplary tether-cutting device (200). The tether-cutting device (200) may comprise a proximal handle (202) attached to a catheter assembly (210), including a catheter, an inner shaft, and a cutting blade. The catheter comprises an opening (214) at a distal end (216). The operator may thread a tether through the distal opening (214) at the distal end (216) of the catheter. The proximal handle (202) may comprise an actuation mechanism (212) used to control the movement of the components of

the device. For example, the actuation mechanism (212) may be used to control the movement of the cutting blade within the lumen of the catheter. A safety tab (220) may be removably coupled to the actuation mechanism to prevent premature movement of one or more device components, such as the cutting blade. The proximal handle (202) may further comprise one or more ports to allow devices or substances to enter and exit the device. For example, a tether port (222) may allow a tether to exit the proximal handle. The proximal end of the tether extending through the port (222) may be held in tension by various mechanisms. For example, the proximal end of the tether may be attached to weights. The proximal handle (202) may further comprise various flush ports for introducing fluids into the various components of the device. For example, an outer flush port (224) may be in fluid communication with the catheter, an inner flush port (226) may be in fluid communication with the inner shaft, and a cutting blade flush port (228) may be in fluid communication with the cutting blade.

**[0030]** In some variations, the proximal handle coupled to the catheter assembly may be configured to allow the operator to control the operation of the tether-cutting device. Any suitable mechanism may be used to couple the catheter assembly to the proximal handle. For example, the catheter, the inner shaft, and the cutting blade may be held in place inside of the proximal handle by friction fit. In another example, non-movable components, such as the catheter and/or the inner shaft may be soldered or molded to the proximal handle. In another example, non-movable components may be secured to proximal handle using screws, brackets, or pins. The proximal handle may have an outer shell defining a substantially hollow inner body. Various components of the tether-cutting device may be housed within the inner body of the proximal handle. The handle may have a proximal portion comprising one or more contours that are configured to allow an operator to easily grip the handle. For example, the proximal portion of the outer shell may have one or more convex curves (e.g., contours (227) of FIG. 2B) to facilitate gripping of the handle, and may be sized such that a user can easily fit his or her hand to the handle. The outer shell may further comprise one or more indentations to provide for comfortable finger placement on the handle. The handle may be made of any suitable material. The proximal handle may further comprise various ports to accommodate the entry and exit of various devices and/or substances through the components of the tether-cutting device. For example, the proximal handle may comprise a port through which the tether exits the handle (e.g., tether port (222) of FIGS. 2A-2B). The proximal

handle may also include various flush ports that allow the operator to introduce liquid, such as saline solution, into various components of the device. For example, an outer flush port may be in fluid communication with the catheter lumen in order to allow the operator to flush liquid through the catheter lumen. An inner flush port may be in fluid communication with the inner shaft in order to allow the operator to flush liquid through the inner shaft lumen. A cutter flush port may be in fluid communication with the lumen of the cutting blade in order to allow the operator to flush liquid through the cutting blade lumen. Various flush ports (e.g., ports (224, 226, 228) depicted in FIG. 2B) may allow entry or exit of liquids such as saline solution, contrast agents, medicaments, or any suitable liquid, into or out of the device. Further, any of the ports described above may also allow introduction of devices, such as implant delivery device, catheters, imaging devices, or any suitable device into the lumen of any of the components of the catheter system.

**[0031]** The outer shell of a proximal handle may comprise one or more openings to accommodate various components, such as buttons, dials, wheels, ports and/or structures that may be used to control operation of the device. For example, the outer shell may comprise an opening configured to house an actuation mechanism such that the operator can control an actuation mechanism while gripping the proximal handle. A portion of the actuation mechanism may protrude out of the opening in the outer shell while another portion may be housed within the inner body. The actuation mechanism may be in the form of a rotatable wheel that may be turned in order to move the cutting blade. However, the actuation mechanism may comprise any suitable configuration, such as rotatable sphere, a flat, rectangular band, or a rectangular or cylindrical notch. Further, the actuation mechanism may comprise any suitable cross section including ovular, triangular, square-shaped, or rectangular. The actuation mechanism need not be moved by rotation, but may instead be moved in any suitable manner, including sliding, pulling, or pushing. For example, the actuation mechanism may be in the form of a flat moveable belt or band that is coupled to the cutting blade, such that when the operator slides the belt the inner shaft is moved in a corresponding fashion. Alternatively or additionally, the actuation mechanism may be in the form of a sliding notch that is coupled to the cutting blade, such that when the operator slides the notch, the cutting blade is moved in a corresponding fashion. The actuation mechanism may also be in the form of a switch or button, such that pushing the switch or button may be

used to facilitate the motion of the cutting blade. The actuation mechanism may be used to facilitate the movement of the cutting blade in any suitable manner.

**[0032]** In one variation, the actuation mechanism may be coupled to the cutting blade within the inner body of the proximal handle. The actuation mechanism may be coupled to a lead screw, and the lead screw may be coupled to the cutting blade such that when the actuation mechanism is turned the lead screw causes the cutting blade to move. The actuation mechanism may be coupled to the lead screw in any suitable manner, including those discussed below. The lead screw may be coupled to the cutting blade in any suitable manner. For example, the lead screw may be fixedly attached to the cutting blade such as by molding or soldering. The lead screw may act to facilitate movement of the cutting blade in any suitable fashion. For example, threading on an exterior surface of the lead screw may interact with a nut, such that as the actuation mechanism rotates the lead screw, the threading of the lead screw interacts with an interior surface of the nut, moving the set screw forward, thereby moving the cutting blade forward. Various mechanism may be used in the place of a lead screw to facilitate the movement of the cutting blade, as discussed below.

**[0033]** Various mechanisms, such as gears, a rack and pinion, a slider crank mechanism, a cam and roller, friction wheels, pulleys, or any other suitable mechanism may be employed to actuate the cutting blade. These mechanisms may directly actuate the cutting blade, or they may engage with a lead screw or other similar apparatus attached to the cutting blade to facilitate movement of the cutting blade. Although examples below describe a cutting blade interacting with various mechanisms to translate and/or rotate the cutting blade, similar configurations apply to variations in which the cutting blade is coupled to a lead screw, which may interact with any of the mechanisms described below in a similar manner. For example, gears may be used to translate and rotate the cutting blade. In one variation of the devices described herein, the actuation mechanism may be coupled to a gear, and the gear may be coupled to a threaded or notched surface on the cutting blade. Moving or turning the actuation mechanism turns the gear, and the gear engages the threading or notches on the surface of the cutting blade to move it forward and/or rotate it. For example, the cutting blade may comprise helical threading extending around and along a portion of the proximal end. When the protrusions of the actuation mechanism engage the threading, the cutting blade may be moved forward and rotated. In another variation, the cutting blade may comprise notches,

indentations, or protrusions around a circumference. When the actuation mechanism engages the circumferentially aligned notches/indentations/protrusions, the cutting blade may rotate about an axis. In another variation, the cutting blade may comprise notches, indentations, or protrusions along the length of the cutting blade, such that when protrusions of the actuation mechanism engage the notches/protrusions/indentations of the cutting blade, the cutting blade is moved forward. A rack and pinion mechanism may also be used to translate and/or rotate the cutting blade. For example, the actuation mechanism may be coupled to, or act as, a gear such that when the user moves or turns the actuation mechanism it engages notches or threading on the cutting blade, converting the rotational motion of the actuation mechanism into linear and/or rotational motion of the cutting blade. A slider crank mechanism may also be used to translate and/or rotate the cutting blade. For example, the actuation mechanism may be coupled to a rotating crank such that when the actuation mechanism is moved, the crank is rotated. The crank may be coupled to a rod, which is coupled to the cutting blade, such that rotation of the crank slides the rod and cutting blade forward (or backward, depending on the direction of rotation). A cam and roller mechanism may also be used to rotate and/or translate the cutting blade. For example, the actuation mechanism may act as, or be coupled to, a cam that rotates about an axis. As the cam rotates, it may engage and turn a roller, which is coupled to the cutting blade to rotate/and or translate it. Friction wheels may also be used to rotate and/or translate the cutting blade. For example, the actuation mechanism may be a friction wheel, and may be coupled to a second friction wheel with a different orientation. The second friction wheel may be frictionally or otherwise coupled to the cutting blade such that rotation of the second friction wheel translates and/or rotates the cutting blade. A pulley system may also be used to rotate and/or translate the cutting blade. For example, the actuation mechanism may be coupled to one or more pulleys, which are coupled to the cutting blade, such that rotation of the actuation mechanism pulls on rope or string connecting the pulleys, and the pulleys translate and/or rotate the cutting blade. Electronic actuation mechanisms may also be used to control the movement of the various components of this device, including the cutting blade. For example, the actuation mechanism may act as an on/off switch to a circuit. The circuit may be electronically connected to the cutting blade such that turning the on/off switch rotates and/or translates the cutting blade.

**[0034]** As discussed above, the tether-cutting devices described herein may comprise one or more actuation mechanisms to control one or more aspects of the movement of the cutting blade. One actuation mechanism may control both (e.g., simultaneous) rotation and translation of the cutting blade. However, in another variation, moving an actuation mechanism may only result in rotation of the cutting blade. Similarly, moving an actuation mechanism may result only in proximal or distal movement of the cutting blade. Multiple actuation mechanisms, each coupled to the cutting blade in any suitable manner, could be used to control the movement of the cutting blade, such that rotation and translation of the cutting blade are controlled by separate actuation mechanisms. In one variation, one actuation mechanism may be coupled to the blade such that movement of the actuation mechanism translates to linear motion, while a separate actuation mechanism may be coupled to the blade such that movement of the actuation mechanism controls rotational motion. For example, a first actuation mechanism may be coupled to gear, and the gear may be coupled to a rod and crank such that turning the gear results in linear motion of the blade. A second actuation mechanism may be coupled to a gear that engages notches, indentations, or threading on the outer surface of the lead screw or cutting blade to rotate the cutting blade about an axis, such that turning the gear results in rotational motion of the blade. Any suitable mechanism may be used to separately control the rotational and translation motion of the cutting blade, including those discussed above in relation to controlling simultaneous rotation and translation. Further, proximal and distal movement of the cutting blade may be controlled by separate mechanisms. For example, a first actuation mechanism may be coupled to a first one way gear that translates the blade only distally. A second actuation mechanism may be coupled to a second one way gear that translates the blade only proximally. Any suitable mechanism may be used to separately control the proximal and distal translation of the cutting blade, including those discussed above.

**[0035]** The proximal handle may also comprise a safety tab removably coupled to the actuation mechanism. The safety tab may be used to hold the actuation mechanism stationary, thereby preventing the movement of components of the device. Various configurations of safety tabs are described below. In some variations, a safety tab is removably coupled to the proximal handle configured to hold the cutting blade in place. The safety tab may physically interfere with the actuation mechanism to prevent it from turning, thereby preventing the cutting blade from moving. For example, the actuation mechanism may comprise a series of

protrusions, and the safety tab may be inserted into the proximal handle between two of the protrusions of the actuation mechanism to prevent the actuation mechanism from being moved.

**[0036]** Any suitable mechanism may be employed to prevent the actuation mechanism from turning. For example, the safety tab could comprise a small cylindrical or rectangular pin that fits into a corresponding opening in the actuation mechanism and the proximal handle. Inserting the pin-like safety tab into the proximal handle and actuation mechanism may prevent the actuation mechanism from turning. Further, any suitable mechanism can be used to hold the cutting blade in place in the lumen of the catheter until the operator is ready to move the blade to cut the tether. In some variations, the tether-cutting device may employ a stopper mechanism to prevent the lead screw from turning, a mechanism to prevent the lead screw from coming into contact with the cutting blade, or a mechanism to prevent movement of the cutting blade. In one variation, a stopper mechanism may be used to prevent the lead screw from turning. For example, a safety tab may be inserted through the proximal handle and into a slot in the sidewall of the lead screw such that the lead screw can no longer turn. In another variation, the lead screw may be moveable within the proximal handle such that the operator can control whether the lead screw is in contact with the cutting blade in order to control whether the cutting blade may move. For example, the lead screw may be held in a first position by the proximal handle in which the lead screw is not in contact with the cutting blade so that the cutting blade cannot be moved. The cutting blade may comprise threading, or may be friction fit within the inner body of the proximal handle, such that it will not move unless the lead screw engages it. The lead screw may be held in position by the proximal handle by any suitable mechanism including friction fit, threading, or a safety tab as described above in relation to preventing the movement of the lead screw. The operator may move the lead screw into a second position in which the lead screw is in contact with the cutting blade to allow the cutting blade to be moved. The operator may move the lead screw from the first position to the second position in any suitable manner. For example, the operator may push or turn the lead screw into place, or may remove a safety tab, in order to move the lead screw into contact with the cutting blade. In a further variation of the devices described herein, a mechanism may be used to prevent the cutting blade from turning. For example, as described above in relation to the lead screw, the cutting blade may comprise a slot in a sidewall. A safety tab may be inserted through the proximal handle and into the slot

to prevent the cutting blade from rotating and/or translating. It should be appreciated that any suitable mechanism may be employed to interfere with the movement of the actuation mechanism, the lead screw, and/or the cutting blade. In some variations, two or more the mechanisms described herein may be combined to prevent movement of the cutting blade.

**[0037]** In one variation, the inner shaft is stationary within the lumen of the catheter. The inner shaft may be held stationary, for example, by coupling the inner shaft to the proximal handle of the tether-cutting device using a friction fit inside the inner body of the proximal handle. The inner shaft may also be held stationary by coupling the inner shaft to the outer shell of the proximal handle. Any suitable mechanism may be used to couple the inner shaft to any surface of the proximal handle including adhesive, soldering, brazing, bonding, fusing, hooks, screws, hinges, frictional or interference fit, collets, flared connection, or grips. Alternatively or additionally, the inner shaft may be moveable within the lumen of the catheter. For example, the inner shaft may be able to move distally and proximally within the lumen of the catheter.

**[0038]** Movement of the inner shaft may be facilitated by an actuation mechanism. The actuation mechanism may be wheel-shaped such that the user facilitates movement of the inner shaft by turning the actuation mechanism. However, the actuation mechanism may comprise any suitable configuration, may have any suitable cross section, and may be moved in any suitable manner, as described above in reference to the actuation mechanism to control the cutting blade. The actuation mechanism need not be moved by rotation, but may instead be moved in any suitable manner, including sliding, pulling, or pushing. For example, the actuation mechanism may be in the form of a flat moveable belt or band, such that the user slides the belt to move the inner shaft. Alternatively, the actuation mechanism may be in the form of a sliding notch, such that the user slides the notch in order to facilitate movement of the inner shaft. The actuation mechanism may also be in the form of a switch or button, such that pushing the switch or button may be used to facilitate the motion of the inner shaft. The actuation mechanism controlling the movement of the inner shaft within the lumen of the catheter may be partially contained within the proximal handle of the tether-cutting device. The inner shaft actuation mechanism may protrude through an opening in the outer shell of the inner shaft so that the operator may engage the actuation mechanism. The actuation mechanism may operate to control the movement of the inner shaft in any suitable manner.

For example, the actuation mechanism may be coupled to a lead screw, the rotation of which results in proximal or distal translation of the inner shaft. Any suitable mechanism such as gears, a rack and screw, a rack and pinion, a slider crank mechanism, a cam and roller, a crank and rod, friction wheels, pulleys, or any other suitable mechanism may be employed to actuate the inner shaft. The operation of these mechanisms in relation to movement of the cutting blade, as described above, apply equally to the operation of these mechanisms when employed to facilitate the movement of the inner shaft.

**[0039]** One variation of a tether-cutting device with a moveable inner shaft may also include a safety mechanism to hold the inner shaft stationary within the lumen of the catheter until the operator is ready to move the inner shaft. This mechanism may comprise an inner shaft safety tab coupled to an actuation mechanism, where the safety tab operates to physically interfere with the movement of the actuation mechanism, thereby preventing movement of the inner shaft. For example, the actuation mechanism may comprise a series of protrusions, and the inner shaft safety tab may be inserted into the proximal handle and between two protrusions of the actuation mechanism to prevent the actuation mechanism from being moved. However, any suitable mechanism may be used to prevent movement of the actuation mechanism, including those described above in reference to a safety tab to prevent the cutting blade actuation mechanism from rotating and/or translating the cutting blade.

**[0040]** In some variations of the tether-cutting device described herein, the cutting blade may be simultaneously rotated and translated about the inner shaft to cut the tether. Simultaneous rotation and translation may allow the cutting blade to exert a shearing or slicing force on the tether, such that the cutting blade can effectively cut through strong surgical tethers. However, in other variations of the tether-cutting device, the cutting blade may not be simultaneously rotated and translated. In one example, the device may comprise a blade that may only be translated. In another example, rotation and translation may be controlled by different mechanisms.

**[0041]** In some variations, the cutting blade may be both proximally and distally translated within the catheter lumen with similar or identical friction and tracking force. That is, the operator may be able to move the cutting blade both proximally and distally within the lumen of the catheter with substantially equal effort. The ability to easily advance and withdraw the

cutting blade may allow for greater flexibility in the maneuvering of the blade, and may facilitate repositioning of the cutting blade. For example, the operator may advance the catheter, begin to actuate the blade, but subsequently realize that the catheter should be repositioned. The bidirectional translation of the tether-cutting device allows the operator to move the blade proximally within the lumen back to its more-proximal location and reposition the catheter. Further, the ability to both proximally and distally translate the blade gives the operator more than one chance to cut the tether in case of a malfunction. For example, if the blade is not successful in cutting the tether, the operator can re-position the cutting blade and repeat the cutting process.

**[0042]** FIG. 3A shows one exemplary variation of a tether-cutting device (300) that includes a catheter (304), a cutting blade (308), and an inner shaft (306). The catheter comprises a proximal end, a distal end (316), a lumen (332) that extends between the proximal and distal ends, and a distal opening (314). A distal portion of the catheter (304) may be tapered toward the distal opening (314). The cutting blade (336) comprises a proximal end (not pictured in FIG. 3A), a distal end (336), and a lumen (338) that extends between the proximal and distal ends. The inner shaft comprises a proximal end (not pictured in FIG. 3A), a distal end (342), and lumen (344) that extends between the proximal and distal ends. The inner shaft (306) and the cutting blade (308) are coaxially disposed within the catheter lumen (332). In this variation, the inner shaft (306) is disposed within the cutting blade lumen (338). This concentric arrangement is further depicted in FIG. 3C, which is a cross-sectional view taken at line 3C-3C in FIG. 3A. FIG. 3C depicts the inner shaft (306) disposed within the cutting blade (308), and the cutting blade (308) disposed within the catheter (304). The cutting blade (308) may be moveable about the inner shaft (306) within the lumen (332) of the catheter. The sidewall (348) of the catheter of FIG. 3A comprises first (350) and second openings (352). The second opening (352) is distal to the first opening (350). In FIG. 3A, the first opening (350) and the second opening (352) are circumferentially aligned along the sidewall (348) of the catheter, with a length of the catheter (354) spaced between them. However, in some variations of the tether-cutting device described herein, the first and second openings may not be circumferentially aligned and may instead be offset from each other so that each opening is at a different circumferential location on the catheter. Further, the length of catheter (354) between the openings may be of any suitable length. A tether (318) may be threaded into the lumen (332) of the catheter (304) through the distal

opening (314), out of the lumen (332) of the catheter (304) through the second opening (352), and back into the lumen (332) of the catheter (304) through the first opening (350). The tether (318) may then be extended from the first opening (350) into the lumen (344) of the inner shaft (306) such that the tether (318) extends across a portion of the catheter lumen (332) at an angle ( $\alpha_1$ ) which is shallow enough to facilitate low tracking force when advancing the cutting device to, or withdrawing from, the target site.

**[0043]** As shown in FIG. 3A, the cutting blade (308) may have a first position, in which the distal end (336) of the cutting blade (308) is proximal to the distal end (342) of the inner shaft (306). When the cutting blade (308) is in the first position as depicted in FIG. 3A, the inner shaft (306) may protect the tether (318) from being cut by the cutting blade (308) by retaining the tether distal to the cutting blade. When the cutting blade (308) is proximal to the inner shaft (306), the tether (318) cannot be cut by the cutting blade (308). This arrangement may help to protect the tether (318) from being prematurely cut when the cutting blade (318) is held in the first position.

**[0044]** FIG. 3B shows a variation of the tether-cutting device (300) in which the cutting blade (308) has been moved from the first position described in FIG. 3A to a second position shown in FIG. 3B. In FIG. 3A, the distal end (336) of the cutting blade (308) is proximal to the distal end (342) of the inner shaft (306). In FIG. 3B, however, the distal end (336) of the cutting blade (108) has been advanced past the distal end (342) of the inner shaft (306) to cut the tether such that the distal end (336) of the cutting blade is distal to the distal end (342) of the inner shaft. The tether (318), when extended between the first opening (350) and the lumen (344) of the inner shaft (306), forms a path that is traversed by the cutting blade (308) as the cutting blade (308) moves from the first position to the second position. In one variation of this device, the cutting blade (308) is simultaneously rotated and translated about the inner shaft as it moves from the first to second position. The simultaneous rotation and translation may create a shearing or slicing effect to effectively cut through the tether. Tethers used in surgical settings must be strong enough to hold pieces of tissue together, and therefore may be very difficult to cut. The slicing motion of the cutting blade (308) created by simultaneous rotation and translation may provide the benefit of allowing the cutting blade (308) cut through very strong material.

**[0045]** Devices and methods described herein may also provide the benefit of preventing the formation of loose pieces of tether after the tether has been cut. As described above and depicted in FIG. 3A, the tether is extended across only the portion of the catheter lumen (332) between the first opening (350) and the inner shaft (306). Therefore, when the cutting blade (308) moves from the first position to the second position, the cutting blade (308) only cuts the tether (318) at one point along the length of the tether. This may provide the advantage of preventing the formation of loose pieces of tether. If the tether were, for example, fully extended across the lumen of the catheter, the cutting blade may come into contact with the tether at more than one point. This may result in the formation of a piece of tether that is not attached to either the target site or the proximal end of the tether. Loose pieces of tether are problematic because they may exit the catheter and move into the body of the subject.

**[0046]** Devices and methods described herein may also provide the benefit of preventing the tether from escaping the path of the cutting blade. In the arrangement depicted in FIGS. 3A and 3B, a tether may be extended from the first opening (350) in the catheter and into to the lumen (344) of the inner shaft. When the cutting blade (308) is moved distally within the catheter lumen along the inner shaft (306), it traverses the path of the tether (318) extended between the first opening (350) and the inner shaft lumen (344). In this arrangement, even if the tether (318) were to become slack, the cutting blade (308) will come into contact with the tether (318) as the cutting blade (308) is moved distally. Thus, the variation depicted in FIGS. 3A and 3B prevents the tether (318) from being able to escape the path of the cutting blade (308).

**[0047]** In some variations, the inner shaft may be kept stationary within the lumen of the catheter. This may help simplify the operation and/or manufacturing of the device, reduce operator error, and/or reduce the amount of time required to operate this device. Further, it may result in less risk of a malfunction of the device related to unintended movement of the inner shaft. In other variations, the inner shaft may be movable within the lumen of the catheter. Proximal and distal movement of the inner shaft may allow the operator to adjust the angle  $\alpha_1$  (as shown in FIG. 3A) of the tether when it extends between the first opening of the catheter and the lumen of the inner shaft. This ability to move the inner shaft may provide the benefit of allowing the operator to adjust the tracking force of the tether and/or facilitate cutting the tether. The inner shaft may have a pre-determined range of motion within the

lumen of the catheter where the inner shaft is able to move proximally and distally within the range. The tether-cutting device may have a retracted configuration in which the inner shaft is moved proximally within the catheter lumen, and an extended configuration in which the inner shaft is moved distally within the catheter lumen. When the inner shaft is moved proximally into the retracted configuration, the angle between the tether and the lumen of the inner shaft ( $\alpha_1$  in FIG. 3A, for example), may be reduced. A reduction in  $\alpha_1$  may help to reduce the amount of force that is used to advance the tether-cutting device (e.g., the tracking force) over the tether. Reduced tracking force may facilitate the advancement of the catheter assembly over the tether. When the inner shaft is moved distally into the extended configuration the angle  $\alpha_1$  is increased. An increase in  $\alpha_1$  may increase the portion of the tether that crosses the path of the cutting blade, which may facilitate the cutting of the tether. Increasing  $\alpha_1$  may also increase the tracking force such that the tether-cutting device is less likely to slip while the operator is in the process of advancing the cutting blade to contact and cut the tether.

**[0048]** FIG. 4A depicts an exemplary variation of a distal portion of a catheter (404) of a tether-cutting device. As depicted in FIG. 4A, the catheter (404) may be substantially cylindrical in shape. However, in other variations, the catheter may be any suitable shape. For example, the catheter may have a square-shaped, rectangular, ovular, or triangular cross-section. The catheter may comprise an opening (414) at the distal end (416). This opening may be configured to receive a tether. The catheter may have a distal tip portion (456) at the distal end (416). In some variations, the distal tip portion (456) may be tapered or have a substantially conical profile. That is, in the tip portion, the circumference of the catheter may narrow as it reaches the distal opening (414). The distal end (416) of the catheter (404) may have an atraumatic rounded edge (458). A rounded edge may prevent the catheter (404) from damaging an outer catheter through which the cutting catheter is advanced and/or the patient as the catheter (404) is advanced to the target site. Further, a rounded edge may prevent the catheter (404) from partially or fully cutting the tether (418) in an undesired location, or at an undesirable point in time.

**[0049]** As stated above, the catheter may comprise one or more openings in the sidewall (448) of the catheter. For example, the catheter (404) may have a first opening (450) and a second opening (452), as depicted in FIG. 4A. The openings may be configured to receive a

tether. The openings may be of any suitable shape, such as oval, round, rectangle, or square shaped. The openings may also be of any suitable size to allow a tether to pass through. The openings may also have rounded or smoothed edges. Rounded or smoothed edges may provide the benefit of preventing the opening from cutting or damaging the tether such as, for example, during the threading of the tether, and/or as the tether is tensioned, and/or as the catheter is advanced over the tether to the cut location. The openings may be aligned with respect to each other in any suitable manner. For example, the openings may be circumferentially aligned, as depicted in FIG. 4A. However, the openings may have any suitable alignment. The space between the openings (454) may be of any suitable distance. The space between the openings may comprise a groove or depression (460) as shown in FIG. 4A. The depression (460) may be of sufficient width to contain the tether. This depression (460) may provide the benefit of directing the path of the tether as it is extended between the second opening (452) and the first opening (450). The depression (460) may be of any suitable depth or width to house a tether. An additional benefit of a depression (460) between the openings in the sidewall (448) of the catheter (404) is that it may help to keep the tether in place and in tension as the cutting blade (408) is advanced to cut the tether. For example, the depression may prevent the tether from moving laterally as the cutting blade comes into contact with the tether (e.g. the rotation of the cutting blade may push the tether in a lateral direction, and the depression may help keep the tether stationary). Holding the tether in place may facilitate the cutting of the tether. Alternatively or additionally, the catheter may comprise a tether lumen between the first and second openings, where the lumen may partially or completely enclose a tether extending between the first and second openings. In some variations, the lumen may be located within the thickness of the sidewall of the catheter. Alternatively, the catheter may not comprise a groove or depression between the first and second openings.

**[0050]** The catheter may be made of any suitable material such as polymer, plastic, metal, impregnated textile or cloth, natural or synthetic rubber, natural or synthetic fibers (including woven and/or braided fibers). The catheter may be flexible, so as to facilitate easy movement of the catheter through the subject. The catheter need not have a uniform material in all portions of the catheter. For example, the catheter may be made of plastic at some locations, and metal at others.

**[0051]** FIG. 4B depicts the inner shaft (406) situated within the lumen (432) of the catheter (404). In FIG. 4B, the distal end (442) of the inner shaft (406) is proximal to the first opening (450) in the sidewall (448) of the catheter. However, it should be appreciated that the distal end (442) of the inner shaft (406) could be situated at any point within the lumen (432) of the catheter. For example, the distal end (442) of the inner shaft (406) may be aligned with any point along the length of the first opening (450), or the distal end (436) of the inner shaft (406) could be distal to the first opening (450). For example, the distal end of the inner shaft (406) could be situated between the first opening (450) and the second opening (452). Further, the distal end (442) of the inner shaft (406) could be aligned with, or positioned distal to, the second opening (452). FIG. 4B shows the inner shaft (406) as having a circular cross section, but it should be appreciated that the inner shaft (406) can be any suitable shape. For example, the inner shaft may have a square-shaped, rectangular, triangular, or ovular cross section. Further, the inner shaft (406) can be made of any suitable material. The inner shaft (406) may be flexible, or it may be rigid. Further, as stated above, the inner shaft (406) may be held stationary within the lumen (432) of the catheter (404), or it may be moveable. For example, the inner shaft (406) may be able to be moved proximally and distally within the lumen (432) of the catheter, as described above. The distal end (442) of the inner shaft (406) may be blunted or rounded. An advantage of an inner shaft (406) with a blunted or rounded distal end is that it may prevent damage to or unintended cutting of the tether. A rounded or blunted distal end (442) of the inner shaft (406) may protect the tether from being cut at an undesired location, or at an undesired point in time.

**[0052]** As described above, the inner shaft (406) may comprise a lumen. The lumen of the inner shaft (406) may be configured to house a tether. The inner shaft lumen may have any suitable diameter. For example, the diameter of the inner shaft lumen may track closely with the width of a tether, such that there is very little excess space when a tether is housed within the lumen of the inner shaft (406). However, the diameter of the inner shaft lumen may also be much larger than the width of a tether. The inner shaft (406) may be held within the lumen (432) of the catheter in any suitable manner. The inner shaft (406) may also be connected to the proximal handle in any suitable manner. For example, the inner shaft (406) may be molded to a surface of the proximal handle. In another variation, the inner shaft (406) may be held in place within the hollow inner body of the proximal handle by frictional forces. For example, the inner shaft may be held within the inner body of the proximal handle by friction

fitting a proximal portion of the inner shaft (406) housed within the inner body to an inner surface of the proximal handle.

**[0053]** FIG. 4C depicts the cutting blade (408) situated within the lumen (432) of the catheter (404), and disposed over the inner shaft (406). As described above, the cutting blade (408) may be movably disposed about the inner shaft (406) in any suitable manner. For example, the cutting blade (408) may be able to be rotated and moved distally and proximally about the inner shaft (406) within the lumen (432) of the catheter (404). The distal end of the cutting blade (408) may have a sharpened edge, suitable for cutting a tether. The cutting blade may comprise a distal portion with a sharpened edge, and a proximal portion with a flexible shaft. The cutting blade (408) may be made of any suitable material. For example, the cutting blade may be made of stainless steel, metal, liquid crystal polymer, natural or synthetic gems, or ceramic. In some variations, the cutting blade may be made of heated materials such as nichrome, and/or any conductive material and heated with electrical energy. A cutting blade comprised of any of the listed materials may be also combined with energy output such as radiofrequency (RF), vibratory energy, or laser-based energy to facilitate cutting the tether. The cutting blade may also be made of one or more materials. For example, the sharpened edge of the cutting blade may be made of metal, whereas the body of the cutting blade may be made of plastic, and/or braided or woven polymers and/or metallic alloys. In some variations, the cutting blade may comprise a distal portion made of a rigid material such as metal, and a proximal portion made of a flexible material such as flexible plastic or rubber. For example, in some variations, the cutting blade may comprise a sharpened distal end made of metal, and a flexible shaft made of a flexible plastic. The cutting blade (408), as depicted in FIG. 4C has a circular cross section, but the cutting blade may be of any suitable shape. For example, the cutting blade may have an ovular, square-shaped, rectangular, or triangular cross section.

**[0054]** In devices described herein, the cutting blade may be moveable to any suitable distance within the lumen of the catheter. For example, it may be possible to move the cutting blade along the entire length of the catheter. However, it may also be the case that it is only possible to move the cutting blade a certain distance within the lumen of the catheter. For example, a lead screw in the proximal handle that controls the movement of the cutting blade may only have sufficient threading to move the cutting blade a certain distance within the

length of the catheter. It may also be the case that the lead screw engages with threading on the cutting blade, and the cutting blade may only have sufficient threading to move a certain distance along the length of the catheter. In another variation, there may be a mechanism to prevent the cutting blade from moving past a certain point within the lumen of the catheter. Any suitable mechanism can be used to prevent the cutting blade from moving. For example, the cutting blade may comprise a notch on an outer surface, and the catheter may comprise a slot on an inner surface of the catheter sidewall configured to house or otherwise engage with the notch. The slot may be a full opening in the sidewall of the catheter, or it may be a groove or depression/recess in the catheter sidewall. The notch on the cutting blade and the slot in the catheter may be arranged such that the notch cannot move out of the slot, but can slide along it. Therefore, the length of the slot may correspond to the distance the cutting blade can be moved within the lumen of the catheter. In another variation, the catheter may comprise a notch, and the cutting blade may comprise a slot that functions as described above to restrict the movement of the cutting blade. In another variation, the catheter may comprise a protrusion on an interior surface of the sidewall. The protrusion may extend into the lumen of the catheter such that when the distal end of the cutting blade comes into contact with the protrusion it can no longer advance within the lumen of the catheter. The protrusion may be at any suitable location along the length of the catheter, such as at or near the distal end. In another variation, the distal tip of the catheter may be tapered such that the cutting blade can no longer fit through the catheter lumen due to the reduction in the diameter of the catheter. Thus, the cutting blade is prevented from moving beyond the point of the catheter lumen at which the diameter of the catheter is equal to or less than the diameter of the cutting blade. One advantage of providing a mechanism to stop the cutting blade is that limiting the movement of the blade may prevent the blade from damaging portions of the tether-cutting device. For example, if the blade were able to move along the entire length of the lumen of the catheter, it may come into contact with and damage the sidewall of the catheter.

**[0055]** As shown in FIG. 5A, the tether-cutting device may comprise a proximal handle (502). The proximal handle (502) may allow the operator to control the operation of the tether-cutting device, and control the movement of the various components, such as the cutting blade and/or the inner shaft, for example. The proximal handle (502) may comprise an outer shell (562), defining a substantially hollow inner body. The outer shell (562) may comprise one or more openings to accommodate various components, such as buttons, dials,

wheels, ports and/or structures that may be used to control operation of the device. For example, the outer shell (562) may comprise an opening (566) configured to house an actuation mechanism (512) such that the operator can control the actuation mechanism (512) while gripping the proximal handle (502). In the variation of FIG. 5A, the actuation mechanism (512) may comprise a rotatable disc (e.g., a wheel-shaped element or dial) having a series of protrusions (584) disposed about the outer circumference of the disc. The wheel-shaped actuation mechanism (512) depicted in the variation of FIG. 5A may be turned by the operator to facilitate movement of the cutting blade. As described above, the actuation mechanism may comprise any suitable configuration, such as any suitable mechanism described herein.

**[0056]** The proximal handle may also house a safety tab (520), removably coupled to the actuation mechanism (512). FIG. 5A depicts a safety tab (520) inserted into an opening (568) in the proximal handle (502). The safety tab opening (568) in the proximal handle (502) may allow the safety tab (520) to come into contact with the actuation mechanism (512), in order to prevent the actuation mechanism (512) from moving until the safety tab (520) is removed. The proximal handle (502) may also comprise various ports to allow to entry and exit of various objects through the catheter, inner shaft, or cutting blade. For example, the proximal handle (502) may comprise a tether port (570) at the distal end to allow the tether to exit through the proximal handle. A tether port (570) to allow the tether to exit the proximal handle (502) may allow the tether to be held in tension outside of the device. For example, one or more weights may be attached to the proximal portion (e.g., proximal end) of the tether that extends out of the tether port (570) in order to place the tether in tension. Various mechanisms may be used to hold the proximal portion of the tether in tension. For example, the operator may simply hold the tether in tension as the tether is being cut. The tether-cutting device may also possess mechanisms to hold the tether in tension, such as hooks, grips, pulleys, or any suitable mechanism to hold a tether in tension.

**[0057]** The proximal handle (502) may also include various flush ports that allow the operator to introduce fluids into various components of the device. For example, the outer flush port (572) may be in fluid communication with the catheter lumen in order to allow the operator to flush liquid through the catheter. The inner flush port (574) may be in fluid communication with the inner shaft lumen in order to allow the operator to flush liquid

through the inner shaft. The cutter flush port (576) may be in fluid communication with the cutting blade lumen in order to allow the operator to flush liquid through the cutting blade. Various flush ports may allow entry or exit of liquids into or out of the device. As described above, any of the ports herein may also allow for entry and exit of various devices and/or substances into the tether-cutting device.

**[0058]** FIGS. 5B and 5C are side partial cutaway views of a tether-cutting device (500) showing examples of various mechanisms that may be used to control the movement of the cutting blade. As shown in FIG 5B, an actuation mechanism (512) in the proximal handle (502) of the tether-cutting device (500) may be coupled to a lead screw (578) housed within the inner body (564) of the proximal handle (502). The lead screw may be coupled to the cutting blade, such that movement of the lead screw facilitates movement of the cutting blade. The lead screw may be coupled to the cutting blade in any suitable manner, such as by friction fit of the cutting blade within an opening of the lead screw, fixedly attaching the proximal end of the cutting blade to the distal end of the lead screw (e.g. using an adhesive, soldering, or molding), or any other attachment mechanism. In the variation of FIGS. 5B and 5C, the lead screw (578) is coupled to the cutting blade (508) such that rotation of the lead screw translates into rotation and proximal or distal (depending on the direction the screw is turned) movement (e.g., longitudinal translation) of the cutting blade (508) within the lumen of the catheter.

**[0059]** In FIGS. 5B and 5C, the lead screw (578) rotates when the user turns the actuation mechanism (512) because the actuation mechanism is coupled to the lead screw via friction fit of the lead screw (578) within an opening of the actuation mechanism (512). As described below, the opening of the actuation mechanism may be configured to conform to one or more surfaces of the lead screw to facilitate movement of the lead screw upon turning the actuation mechanism. The lead screw may interact with a nut in the proximal handle to facilitate the longitudinal movement of the lead screw. For example, as shown in FIGS. 5B and 5C, the lead screw (512) is extended through a nut (579), such that when the actuation mechanism rotates the lead screw, threading on the lead screw engages with an interior surface of the nut to move the lead screw proximally or distally (depending on the direction of turning) within the proximal handle. The nut may comprise threading on an interior surface that engages with threading on the lead screw, such that turning of the lead screw causes the threading of the

nut to engage with the threading of the lead screw to translate the lead screw distally or proximally. Thus, when the user turns the actuation mechanism (512), the lead screw (578) moves from a first position, as depicted in FIG. 5B, to the second position, as depicted in FIG. 5C. The nut and lead screw combination may facilitate longitudinal movement of the cutting blade in any suitable manner.

**[0060]** FIGS. 5D and 5E show exemplary variations of the actuation mechanism (512), and lead screw (578) coupled to the actuation mechanism (512). As depicted in FIG. 5D, the actuation mechanism comprises protrusions (584) and an opening (513), which may be configured to engage with the lead screw (578). That is, the opening (513) of the actuation mechanism (512) may be configured to fit the dimensions of the outer surface of the lead screw (578). For example, the actuation mechanism depicted in FIG. 5D comprises two flattened surfaces (516) and two curved surfaces, configured to mirror the surfaces of the lead screw. This may provide the benefit of improving the engagement of the actuation mechanism (512) with the lead screw (578). However, the opening of the actuation mechanism may be configured in any suitable manner with any combination of curved or flat surfaces. As shown in FIG. 5E, the lead screw (578) may extend through the opening (513) of the actuation mechanism (512). In FIG. 5E, the actuation mechanism (512) is friction fit to the lead screw (578), such that when the actuation mechanism rotates, it also rotates the lead screw. The lead screw (578) in FIG. 5E comprises two flattened surfaces configured to fit the two flattened surfaces of the actuation mechanism (512). However, the lead screw may comprise any suitable configuration suitable to fit within an opening of the actuation mechanism. The actuation mechanism may be coupled to the lead screw in any suitable manner. For example, in some embodiments, the lead screw may not extend through an opening in the actuation mechanism. Rather, protrusions on the actuation mechanism may interact with threading or protrusions on the surface of the lead screw such that when the actuation mechanism is rotated or moved the protrusions on the actuation mechanism engage with the threading/protrusions on the lead screw. In another variation, the actuation mechanism may be in physical contact with a surface of the lead screw such that frictional forces allow movement of the actuation mechanism to affect movement of the lead screw.

**[0061]** As described above, mechanisms (e.g. safety tabs) may be used to maintain the cutting blade in a stationary position within the lumen of the catheter until the operator is

ready to cut the catheter. FIGS. 5F and 5G depict two views of a variation of a safety tab (520) that may be used to prevent the actuation mechanism (512) from turning, thereby preventing the cutting blade from moving within the lumen of the catheter. In the arrangement shown in FIGS. 5A, 5F, and 5G, the safety tab (520) may be inserted into an opening (568) in the proximal handle and between two of the protrusions (584) of the actuation mechanism. When inserted between two of the protrusions (584), the safety tab (520) physically interferes with the rotation of the actuation mechanism. In this arrangement, the operator may remove the safety tab (520) from the opening (568) in the proximal handle (502) to allow movement of the cutting blade.

**[0062]** It should be appreciated that any suitable mechanism can be used to prevent the actuation mechanism from being moved. For example, the safety tab could comprise a small cylindrical or rectangular pin that fits into an opening in the actuation mechanism and the proximal handle. Inserting the pin-like safety tab through the proximal handle and into the actuation mechanism may prevent the actuation mechanism from turning. Further, any suitable mechanism can be used to hold the cutting blade in place in the lumen of the catheter until the operator is ready to move the blade to cut the tether. Alternatively or additionally, a tether-cutting device may have a stopper mechanism to prevent the lead screw from turning, a mechanism to prevent the lead screw from coming into contact with the cutting blade, and/or a mechanism to prevent movement of the cutting blade. In one variation, a stopper mechanism may be used to oppose rotational motion of the lead screw. For example, a safety tab or pin may be inserted through the proximal handle and into a slot in the sidewall of the lead screw such that the tab/pin interferes with the rotation of the lead screw.

**[0063]** In another variation, the lead screw may be moveable within the proximal handle such that the lead screw has a first position in which the lead screw is not in contact with the cutting blade, and a second position in which the lead screw is in contact with the cutting blade. In the first position, the lead screw cannot move the cutting blade because the lead screw and the cutting blade are not in contact. The cutting blade may comprise threading, or may be friction fit within the inner body of the proximal handle, such that it will not move unless it is engaged by the lead screw. The lead screw may be held in the first position by the proximal handle may any suitable mechanism, including friction fit, threading, or a safety tab as described above in relation to preventing the movement of the lead screw. In the second

position, the cutting blade may be moved when the lead screw is moved because the cutting blade and the lead screw are in contact. The operator may move the lead screw into contact with the cutting blade in any suitable manner. For example, the operator may push or turn the lead screw into place, or may remove a safety tab in order to move the lead screw into contact with the cutting blade. In some variations, a mechanism may be used to prevent the cutting blade from turning. For example, as described above in relation to the lead screw, the cutting blade may comprise a slot in a sidewall. A safety tab may be inserted through the proximal handle and into the slot to prevent the cutting blade from rotating and/or translating. It should be appreciated that any suitable mechanism can be employed to interfere with the movement of the actuation mechanism, the lead screw, and/or the cutting blade. Further, the mechanisms described herein to prevent movement of the cutting blade may be used alone or in combination.

## **METHODS**

**[0064]** Also described herein are variations of methods for cutting a tether. FIG. 6 is a flowchart representation of one variation of a method for cutting a tether. The method (600) may comprise advancing (602) a tether-cutting device over a tether, applying tension to the tether (604), and simultaneously rotating and distally translating (606) the cutting blade in order to cut the tether. Generally, the operator of a tether-cutting device may advance the catheter assembly, comprising a catheter, an inner shaft, and a cutting blade, over a tether. In some variations, the operator may apply tension to the tether while advancing the catheter assembly over the tether (in addition to applying tension while rotating and translating the cutting blade to cut the tether). Tension may be applied to the tether in any suitable manner, such as those described below. The tether may be connected to a target site in the body of a subject (e.g. as part of an implantable device). In some variations, advancing the catheter over a tether may comprise loading the tether into the tether-cutting device. A loading tool (e.g., a lasso) may be used by the operator to facilitate loading the tether into the device. The loading tool may comprise a loop at one end where the tether can be threaded through. The tool may be then be pulled through the lumen of the catheter(s) to thread the tether through the tether-cutting device. Loading the tether may first comprise threading the tether into the catheter lumen through a distal opening of the catheter, and out of the catheter lumen through a second opening in a sidewall of the catheter. Loading the tether through the device may then

comprise threading the tether from the second opening in the sidewall of the catheter, back into the lumen of the catheter through a first, more proximal opening in the catheter. Loading the tether may next comprise threading the tether from the first opening, and through the lumen of the inner shaft. This loading step may result in a portion of the tether extending partially across the lumen of the catheter, from the first opening in the catheter sidewall to the lumen of the inner shaft. The tether may be threaded through the inner shaft, into the proximal handle, and out of the proximal handle through a tether port.

**[0065]** After the tether is loaded into the device, the operator may apply tension to the tether. One advantage to a method that includes applying tension to a tether is that a tether in tension is easier to cut than a tether that is slack. The operator may apply tension to the tether in any suitable manner. For example, the operator may attach weights to the proximal end of the tether to apply tension to the tether. In some variations, the operator may drape the portion of the tether that is proximal to the catheter assembly over a sterile bar. One or more weights may be clamped onto the proximal end of the tether to apply tension. Any suitable weight may be used to apply tension to the tether. For example, a weighted hemostat (or other surgical tool) may be clamped onto the tether. In another variation of the method described herein, the operator may simply hold the tether in tension. In a further variation of the method described herein, the operator may pull the tether into tension and attach the tether to a mechanism of the tether-cutting device, such as a hook, slot, notch, or any other suitable mechanism in order to maintain the tether in tension. The operator may also utilize mechanisms of the tether-cutting device designed to apply tension to the tether, such as pulleys, wheels, spools, or hooks, or any other suitable mechanism, in order to apply tension to the tether.

**[0066]** The operator may advance the catheter along the tether at any suitable point during the operation of the device. For example, the operator may complete all of the threading steps to load the tether into the device, and then advance the catheter to the target site. In another variation, the operator may only complete a subset of the threading steps to load the tether, and then partially advance the catheter along the tether in order to complete the loading of the tether into the device. For example, the operator may thread the tether into the catheter lumen through the distal opening, thread the tether out of the catheter lumen through the second opening in the sidewall of the catheter, and then partially advance the catheter along the

tether before threading the tether through the rest of the tether-cutting device. In a further variation, the operator may complete the loading of the tether, advance the tether-cutting device to the target site, partially actuate the blade of the tether -cutting device, and subsequently further advance the tether-cutting device along the tether. For example, the operator may begin to actuate the blade, and realize that the device has not been positioned properly, prompting the operator to further advance the tether-cutting device before completing the actuation of the cutting blade to cut the tether.

**[0067]** The operator may control the operation of the device using the proximal handle. After the tether has been loaded into the tether-cutting device, the operator may then use one or more actuation mechanisms in the proximal handle to cut the tether. For example, the operator may move an actuation mechanism that controls the movement of the cutting blade to advance the blade within the lumen of the catheter and cut the tether. In the variation depicted in FIG. 6, the operator may control an actuation mechanism that rotates and translates the cutting blade within a lumen of the catheter. In another variation, the operator may control separate actuation mechanisms to control rotation and translation of the cutting blade. In order to move the cutting blade using the actuation mechanism, the operator may need to deactivate a mechanism designed to hold the cutting blade stationary within the lumen of the catheter. For example, the operator may need to remove a safety tab inserted into the proximal handle and coupled to the actuation mechanism in order to move the cutting blade. In another variation, the operator may remove a safety tab coupled to the cutting blade and/or a lead screw. In a further variation, the operator may merely turn or move a safety tab rather than fully removing it from the proximal handle. After the operator has moved the cutting blade, the operator may replace the mechanism used to hold the blade stationary. For example, after the operator has cut the tether, the operator may use the safety tab to maintain the blade in a stationary position within the lumen of the catheter while the device is extracted from the subject. In one variation, the cutting blade may be configured to move both distally and proximally within the lumen of the catheter. The operator may retract the cutting blade by using an actuation mechanism to move the blade distally within the lumen of the catheter. For example, the operator may move the cutting blade proximally by moving the actuation mechanism in one direction, and distally by moving the actuation mechanism in the opposite direction. In another variation, the operator may actuate separate actuation mechanisms in order to move the cutting blade in opposite directions. An advantage of a

method in which is operator may move the cutting blade both distally and proximally is that the operator may move the cutting blade proximally in order to reposition the cutting blade within the catheter lumen.

**[0068]** Optionally, some variations may comprise translating the inner shaft to facilitate the cutting of the tether. For example, in variations of the tether-cutting device where the tether-cutting device possesses a moveable inner shaft, the operator may control an actuation mechanism to translate the inner shaft within the lumen of the catheter, e.g., translating the inner shaft distally before actuating the cutting blade. For example, the inner shaft may have a predetermined range of movement, and a retracted position and an extended position within the range. The relative position of the inner shaft and the proximal-most sidewall opening of the catheter may affect the tracking force of the tether by changing the angle (e.g., angle  $\alpha_1$ ) of the tether in the lumen of the catheter. The operator may adjust the angle of the tether, and consequently the tracking force, by moving the inner shaft proximally or distally within the lumen of the catheter. For example, in order to reduce the tracking force, the operator may move the inner shaft proximally into a retracted position within the lumen of the catheter. Reduced tracking force may provide the benefit of making it easier for the operator to advance the catheter over the tether. Optionally, the operator may move the inner shaft distally to an extended position within the lumen of the catheter. Moving the tether distally within the lumen of the catheter may increase portion of the tether that is in the travel path of the cutting blade (i.e., so that a greater length of the tether comes into contact with the blade), which may facilitate cutting of the tether. In order to move the inner shaft using an actuation mechanism, the operator may deactivate a mechanism designed to hold the inner shaft stationary within the lumen of the catheter. For example, the operator may remove a safety tab inserted into the proximal handle and coupled to an actuation mechanism in order to move the inner shaft. In another variation, the operator may remove a safety tab coupled to the cutting blade. In a further variation, the operator may merely turn or move a safety tab rather than fully removing it. The operator may at any point wish to maintain the position of the inner shaft within the lumen of the catheter, such as after the operator has moved the inner shaft to a desired location. The operator may reactivate the safety mechanism to hold the inner shaft stationary, for example, by replacing a safety tab into an opening in the proximal handle of the tether-cutting device. It should also be appreciated that in some variations of a tether-cutting device, the operator will not move the inner shaft.

**[0069]** In some variations, the operator may check if the tether has been successfully cut by the tether-cutting device. For example, the operator may pull on the proximal end of the tether, and evaluate whether the tether has been cut. If the tether can be easily pulled, this may signal to the operator that the tether has been fully cut. If some tension still remains in the tether, this may signal to the operator that the tether has not been fully cut, or has not been cut at all. If the tether has not been completely cut (or cut at all), the operator may retract the cutting blade, apply tension on the tether, and then distally advance the cutting blade a second time. Additionally the operator may remove the cutting blade and/or the inner shaft and/or any actuation mechanisms thereof if they are suspected of being damaged while leaving the catheter in place and replace the removed components (e.g. the cutting blade, inner shaft, and/or actuation mechanisms). This may be desirable, for example, if components of the device are damaged and should be replaced, but the operator would prefer to keep the catheter in place while replacing the inner shaft and/or cutting blade. Because the tether may be threaded through the catheter, leaving the catheter in place while replacing other components of the tether-cutting device may provide the advantage of making the process of replacing components less cumbersome by avoiding the need to re-thread the tether through the catheter. . After the operator has confirmed that the tether has been successfully cut, the operator may retract the tether-cutting device from the target site of the subject. The operator may use the proximal handle to pull the catheter assembly away from the target site and out of the subject. Prior to retracting the device, the operator may wish to ensure that some elements of the catheter assembly, such as the cutting blade and the inner shaft, remain stationary within the catheter. As discussed above, the operator may utilize mechanisms, such as safety tabs, to hold the cutting blade and/or inner shaft in place while the device is retracted.

**[0070]** Some variations of methods described herein may comprise introducing fluids or devices into the lumen of the catheter, the inner shaft, or the cutting blade. The proximal handle of the tether-cutting device may comprise various ports to allow the operator to introduce devices and/or substances into the tether-cutting device. An outer port in fluid communication with the catheter lumen, an inner port in fluid communication with the inner shaft lumen, and a cutter port in fluid communication with the cutting blade lumen may allow the operator to introduce fluids into the catheter, the inner shaft, and the cutting blade, respectively. For example, the operator may introduce fluids such as saline solution, contrast

agents, medicaments, or any suitable liquid into any component of the tether-cutting device. The operator may also introduce one or more devices, such as implant delivery devices, catheters, imaging devices, or any other suitable device into any component of the tether-cutting device through the various ports.

**[0071]** While various inventive variations have been described and illustrated herein, a variety of other means and/or structures may be used for performing the function and/or obtaining the results and/or one or more of the advantages described herein, and each of such variations and/or modifications is deemed to be within the scope of the inventive variations described herein. More generally, all parameters, dimensions, materials, and configurations described herein are meant to be exemplary and that the actual parameters, dimensions, materials, and/or configurations will depend upon the specific application or applications for which the inventive teachings is/are used. There are many equivalents to the specific inventive variations described herein. It is, therefore, to be understood that the foregoing variations are presented by way of example only and that, within the scope of the appended claims and equivalents thereto, inventive variations may be practiced otherwise than as specifically described and claimed. Inventive variations of the present disclosure are directed to each individual feature, system, article, material, kit, and/or method described herein. In addition, any combination of two or more such features, systems, articles, materials, kits, and/or methods, if such features, systems, articles, materials, kits, and/or methods are not mutually inconsistent, is included within the inventive scope of the present disclosure.

**[0072]** In the claims, as well as in the specification above, all transitional phrases such as “comprising,” “including,” “carrying,” “having,” “containing,” “involving,” “holding,” “composed of,” and the like are to be understood to be open-ended, i.e., to mean including but not limited to. Only the transitional phrases “consisting of” and “consisting essentially of” shall be closed or semi-closed transitional phrases, respectively, as set forth in the United States Patent Office Manual of Patent Examining Procedures, Section 2111.03.

## CLAIMS

1. A tether-cutting device comprising:
  - a catheter comprising a proximal end, a distal end, a lumen therethrough, and a sidewall, wherein the sidewall comprises a first opening and a second opening distal to the first opening;
  - an inner shaft comprising a proximal end, a distal end, and a shaft lumen therethrough, wherein the inner shaft is disposed within the lumen of the catheter proximal to the first opening;
  - a cutting blade disposed over the inner shaft; and
  - an actuation mechanism coupled to the cutting blade configured to rotate and translate the cutting blade about the inner shaft.
2. The device of claim 1, wherein the inner shaft is stationary within the lumen of the catheter.
3. The device of claim 1, wherein the inner shaft is moveable within the lumen of the catheter.
4. The device of claim 3, further comprising a lead screw coupled to the inner shaft, wherein rotation of the lead screw translates the inner shaft.
5. The device of claim 4, further comprising an actuation mechanism coupled to the lead screw such that moving the actuation mechanism turns the lead screw.
6. The device of claim 3, further comprising a gear mechanism coupled to the inner shaft, wherein rotation of the gear translates the inner shaft.
7. The device of claim 1, further comprising a first configuration wherein a distal end of the blade is proximal to the distal end of the inner shaft, and a second configuration wherein the distal end of the blade is distal to the distal end of the inner shaft.
8. The device of claim 3, wherein the actuation mechanism is configured to move the blade between the first and second configurations in order to cut a tether.

9. The device of claim 1, wherein the distal end of the inner shaft is blunt.
10. The device of claim 1, wherein the blade is tubular.
11. The device of claim 1, wherein the inner shaft is coaxial with the blade.
12. The device of claim 1, further comprising a proximal handle.
13. The device of claim 8, wherein the handle comprises the actuation mechanism.
14. The device of claim 1, wherein the actuation mechanism comprises a lead screw coupled to the blade wherein rotation of the screw rotates and longitudinally translates the blade.
15. The device of claim 9, wherein the actuation mechanism is configured to simultaneously slide the blade along a length of the catheter, and rotate the blade about a longitudinal axis of the catheter.
16. The device of claim 9, wherein the actuation mechanism is configured to bidirectionally move the blade distally and proximally within the catheter.
17. The device of claim 9, wherein the blade is retained within the lumen of the catheter by the actuation mechanism.
18. The device of claim 1, wherein the lumen of the catheter terminates at a distal opening.
19. The device of claim 1, wherein a tether extending from the second opening, through the first opening, and through the shaft lumen extends partially across the lumen of the catheter.
20. A method of cutting a catheter comprising:  
advancing a tether-cutting device over a tether, wherein the tether-cutting device comprises:

a catheter comprising a lumen and a sidewall, wherein the sidewall comprises a first opening, and a second opening distal to the first opening;

an inner shaft comprising a shaft lumen, wherein the inner shaft is disposed within the lumen of the catheter;

and a cutting blade disposed over the inner shaft;

and wherein the tether extends from the second opening, through the first opening, and through the shaft lumen such that a portion of the tether extends partially across the lumen of the catheter;

applying tension to the tether; and

simultaneously rotating and distally translating the blade to cut the portion of the tether that extends partially across the lumen of the catheter.

21. The method of claim 20, wherein rotating and distally translating the blade comprises actuating an actuation mechanism coupled to the cutting blade.

22. The method of claim 21, wherein the actuation mechanism is in a proximal handle.

23. The method of claim 20, furthering comprising actuating the blade to move from a first position in which a distal end of the blade is proximal to a distal end of the inner shaft, to a second position in which the distal end of the blade is distal to the distal end of the inner shaft.

24. The method of claim 20, wherein simultaneously rotating and distally translating the blade comprises moving the blade from the first position to the second position.

25. The method of claim 23, wherein the blade remains in the first position until actuated using the actuation mechanism.

26. The method of claim 20, wherein the blade and the inner shaft are coaxial.

27. The method of claim 20, wherein the tether is a component of a heart implant that has been secured in a heart at an implant site, and wherein the method further comprises advancing the tether-cutting device to the implant site.

28. The method of claim 27, wherein the implant is a valve repair device comprising anchors affixed to tissue and coupled to the tether.

29. The method of claim 20, further comprising proximally translating the blade.

30. The method of claim 20, wherein a length of a tether that extends from the first opening into the shaft lumen forms an angle with respect to a longitudinal axis of the shaft lumen, and wherein the method further comprises adjusting the angle to a first pre-selected angle prior to advancing the tether-cutting device over the tether and adjusting the angle to a second pre-selected angle prior to cutting the tether, wherein the second pre-selected angle is greater than the first pre-selected angle.

31. The method of claim 30, wherein adjusting the angle to the first pre-selected angle comprises proximally translating the inner shaft and adjusting the angle to the second pre-selected angle comprises distally translating the inner shaft.

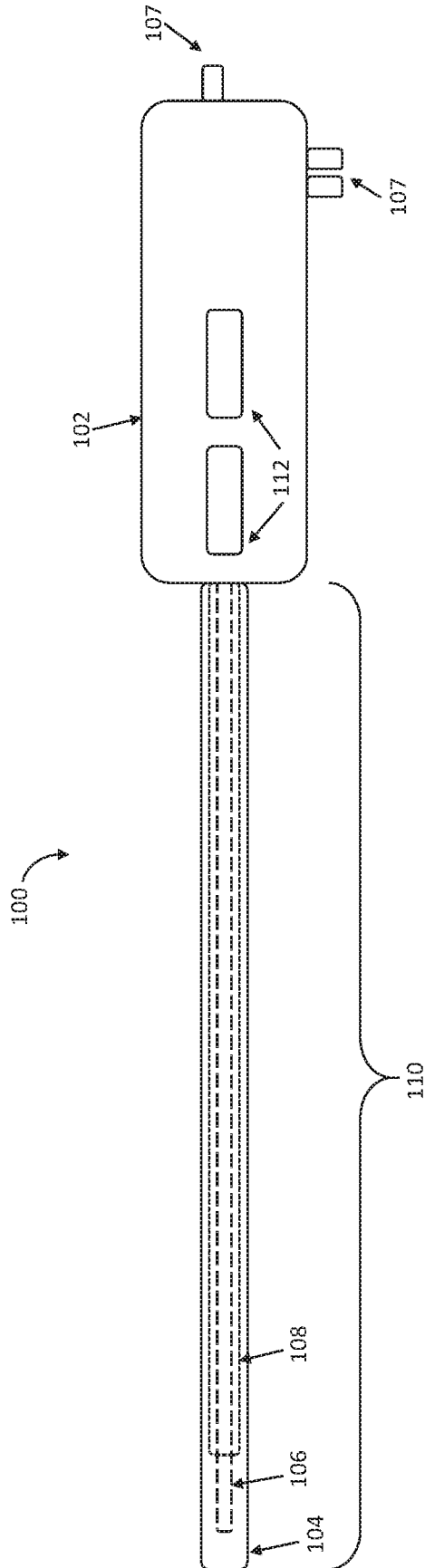

FIG. 1A

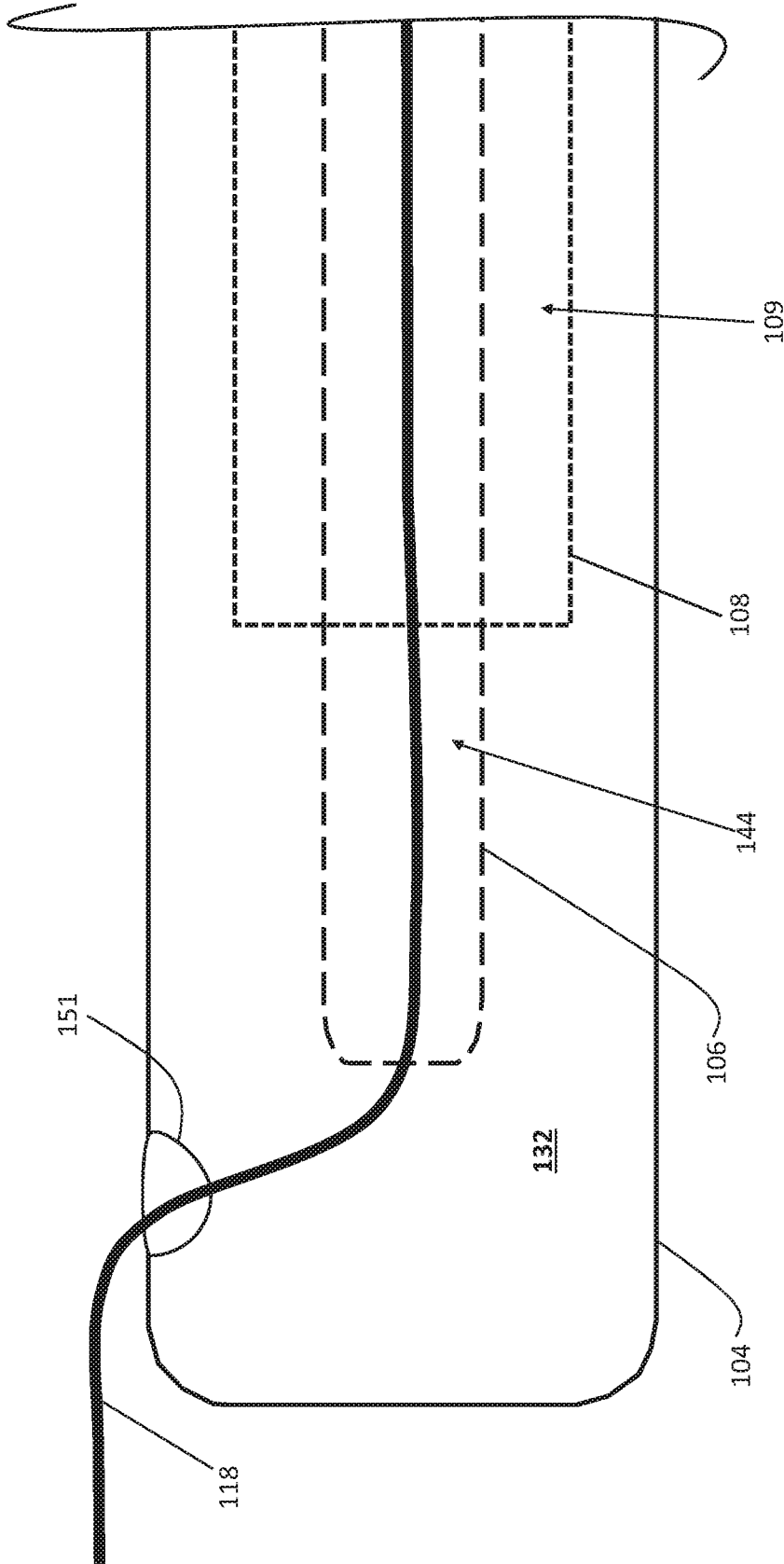

FIG. 1B

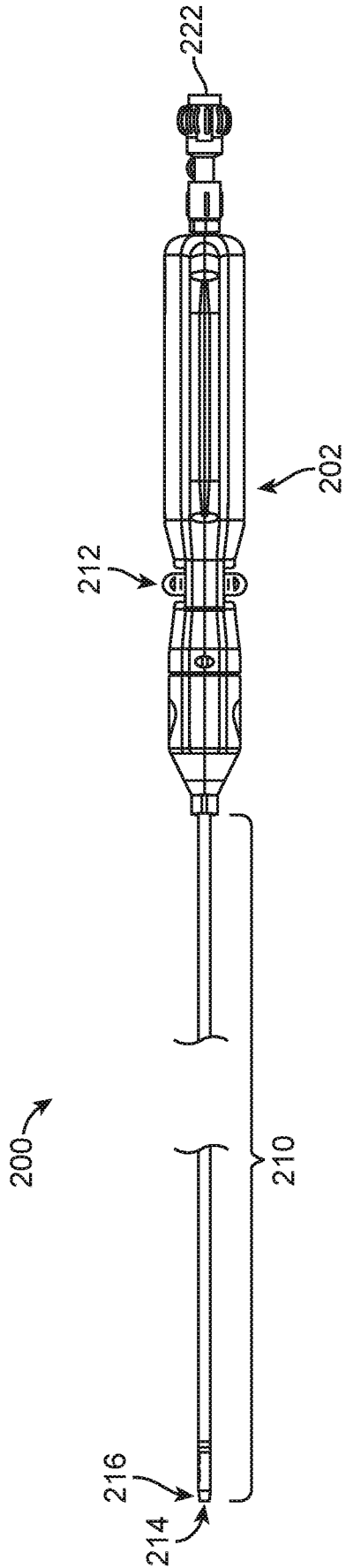

FIG. 2A

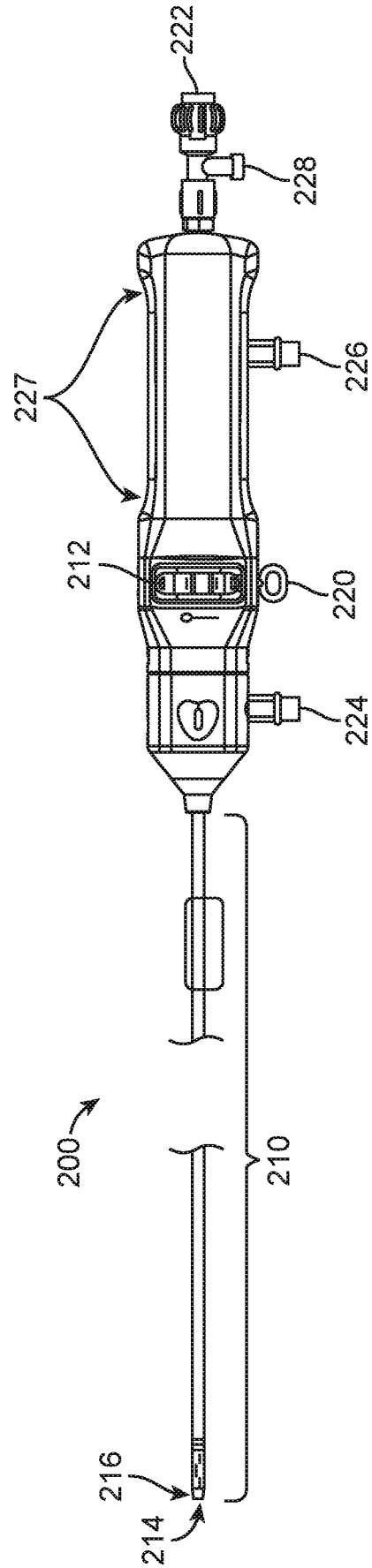

FIG. 2B

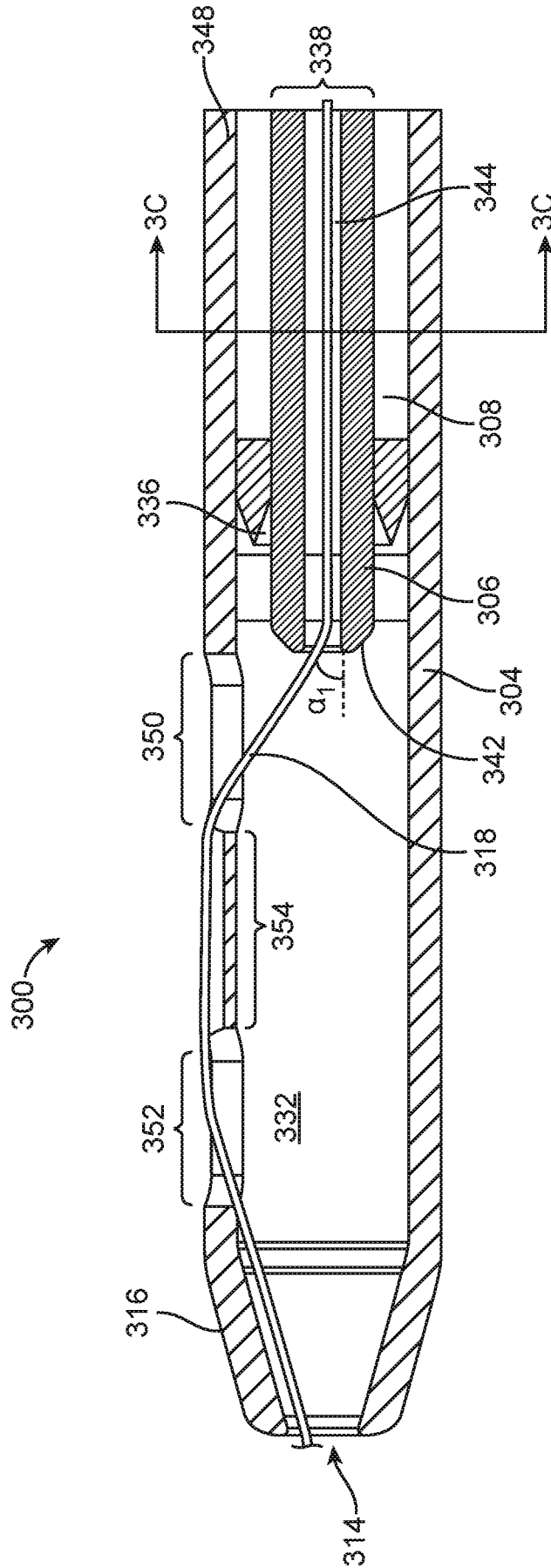

FIG. 3A

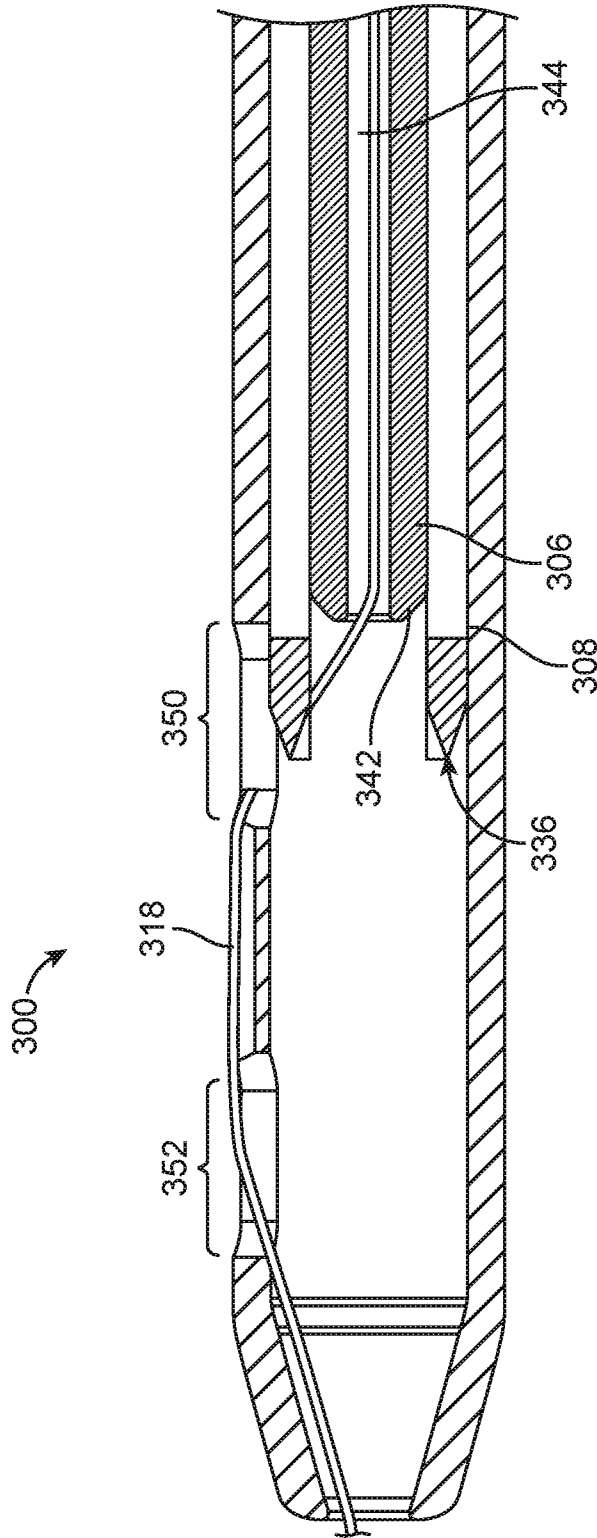

FIG. 3B

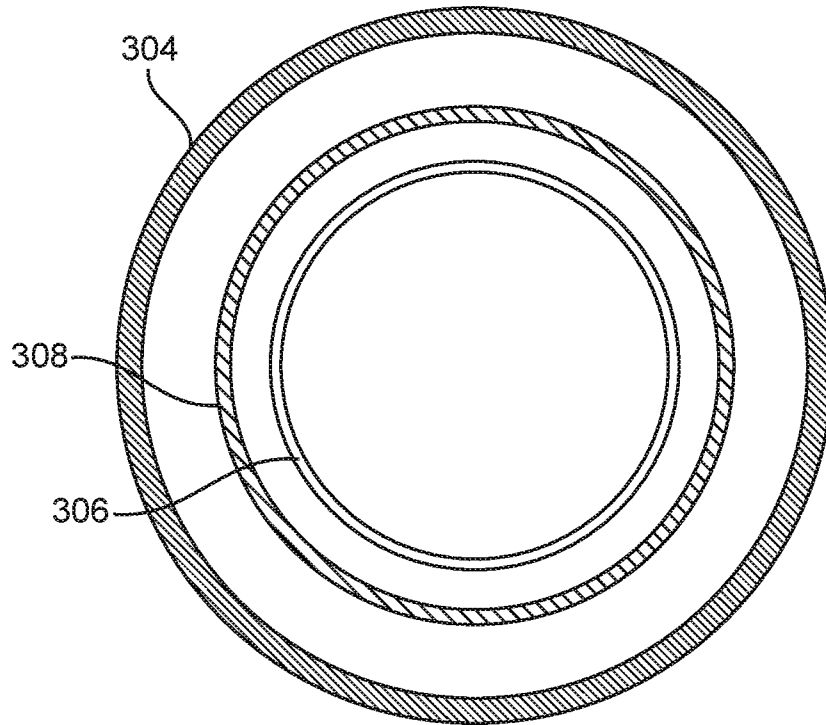

FIG. 3C

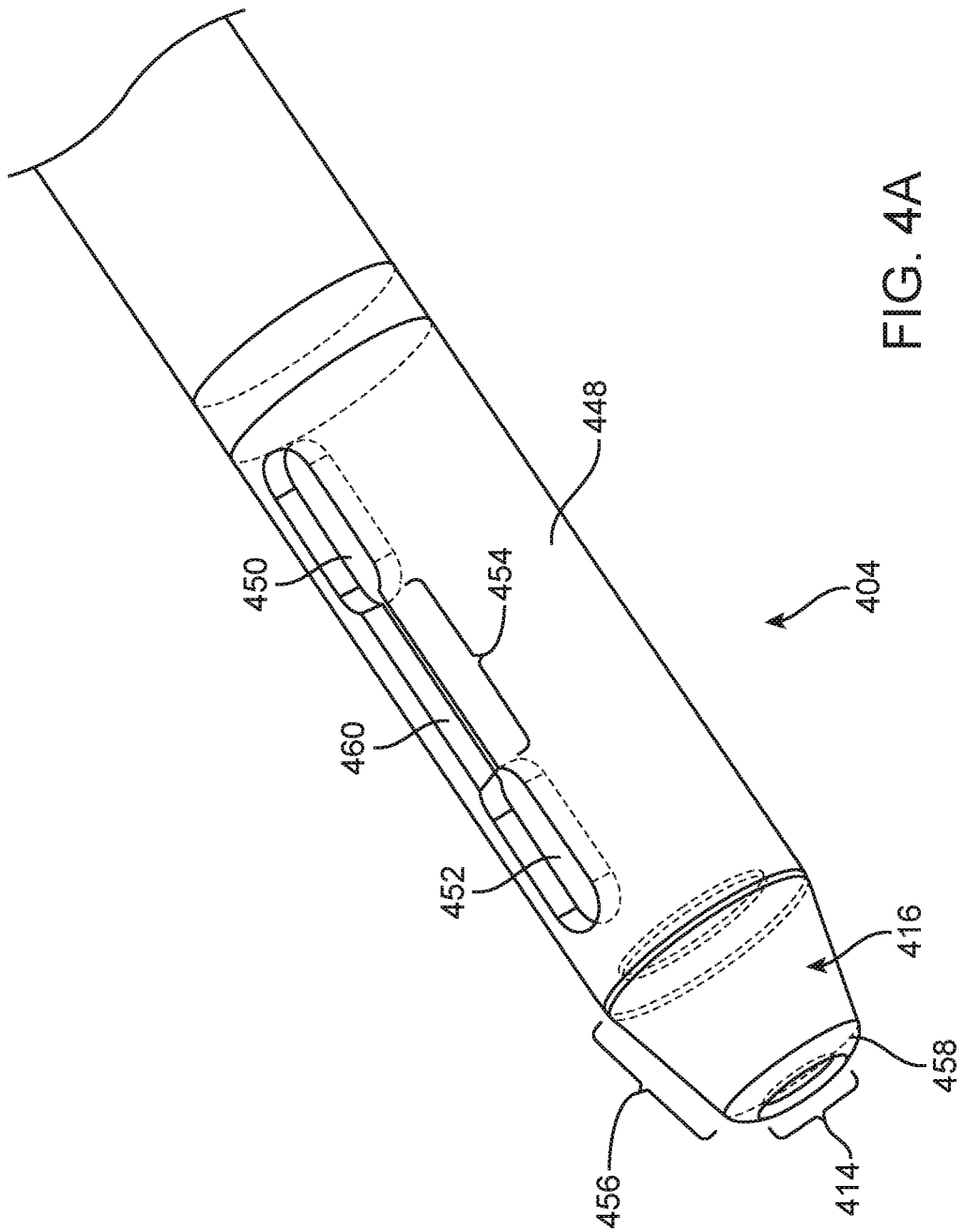

FIG. 4A

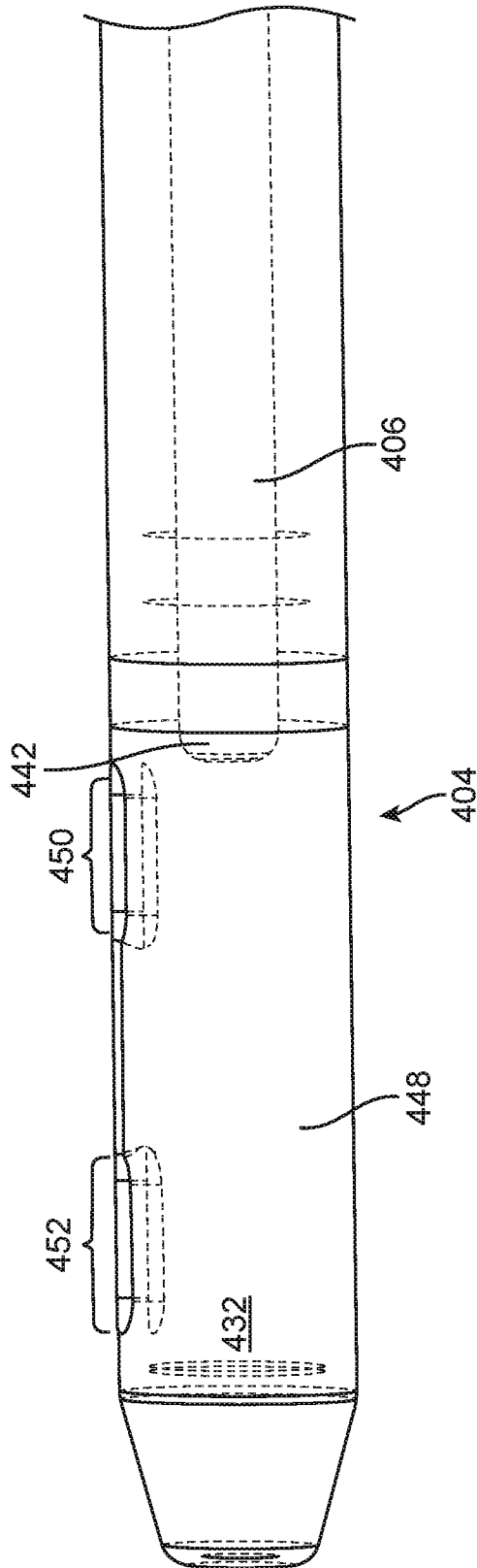

FIG. 4B

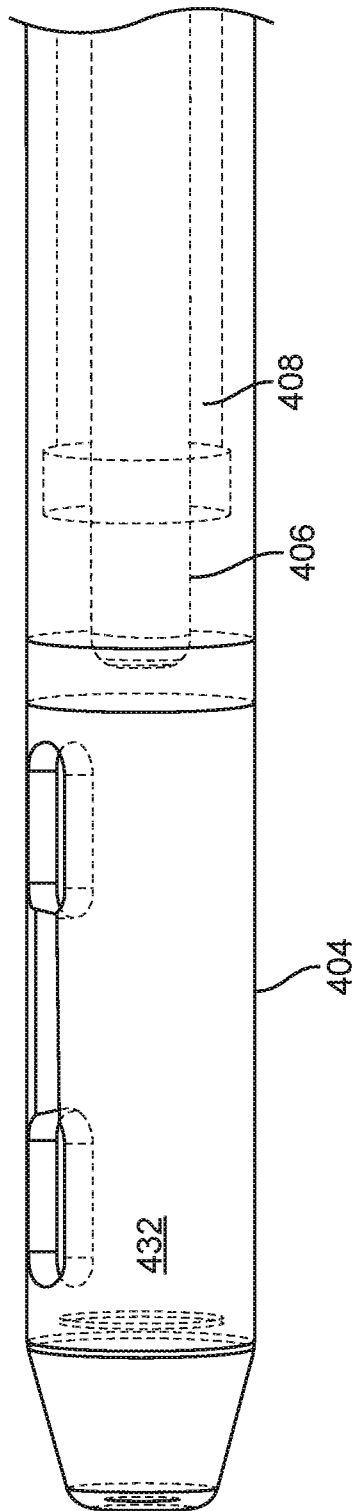

FIG. 4C

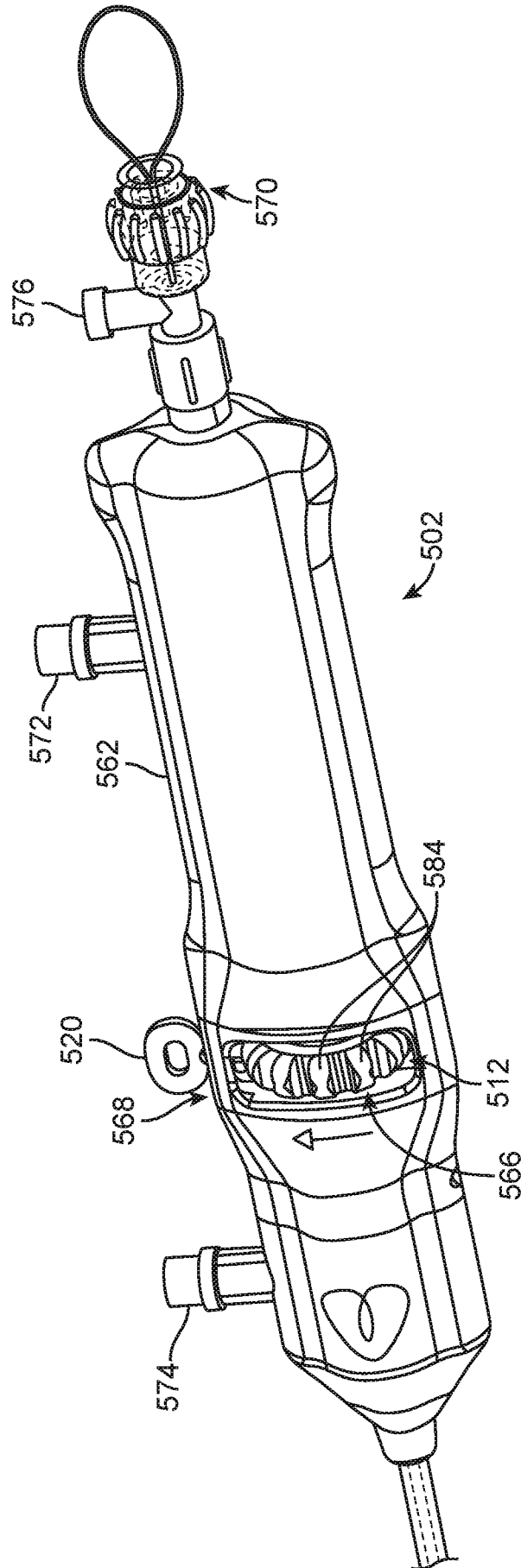

FIG. 5A

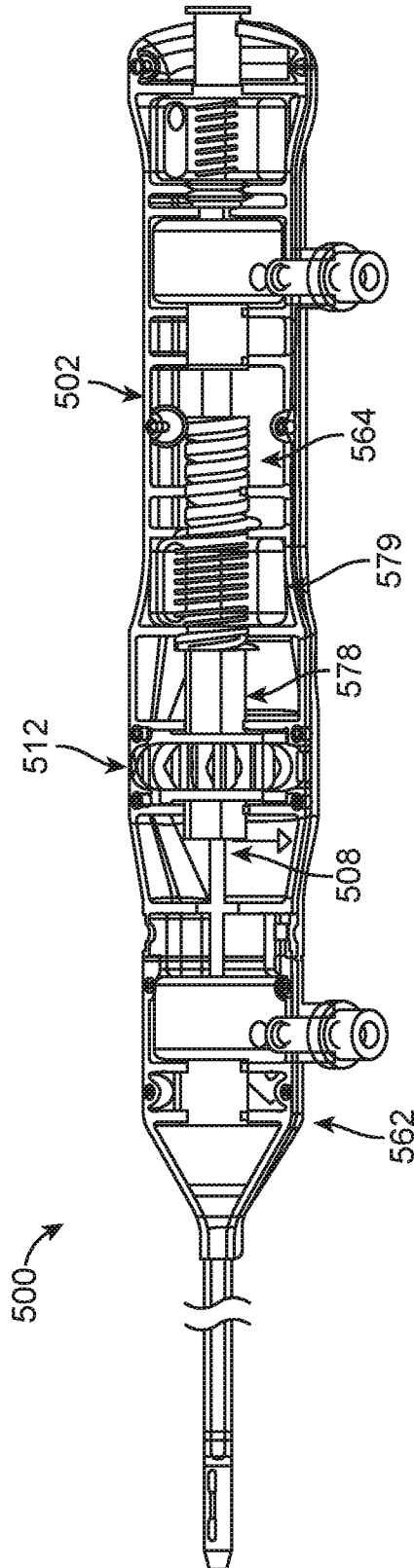

FIG. 5B

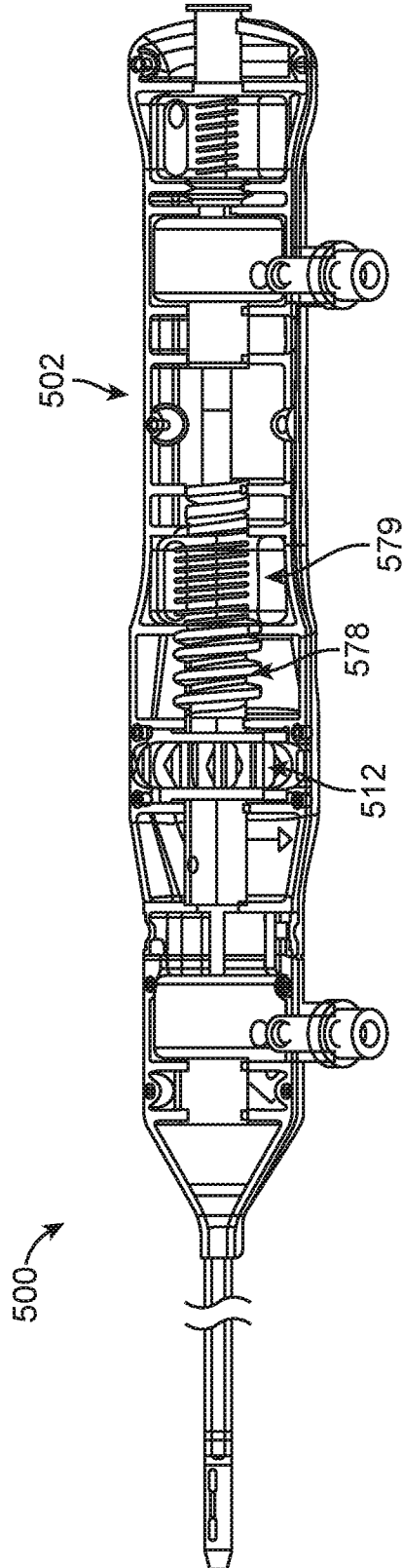

FIG. 5C

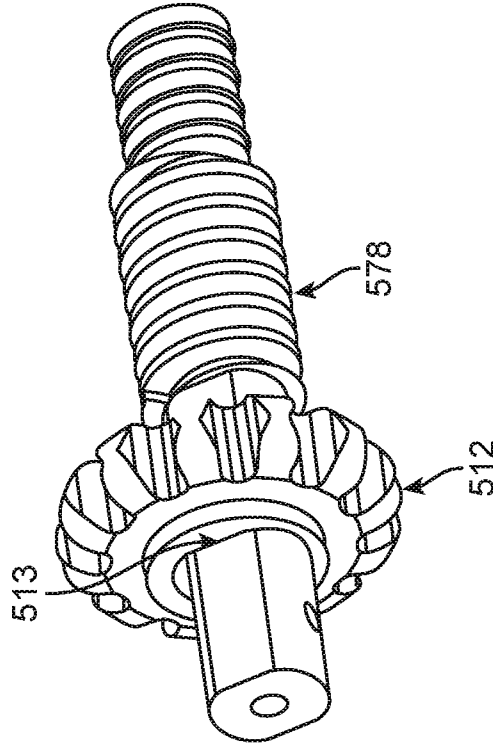

FIG. 5E

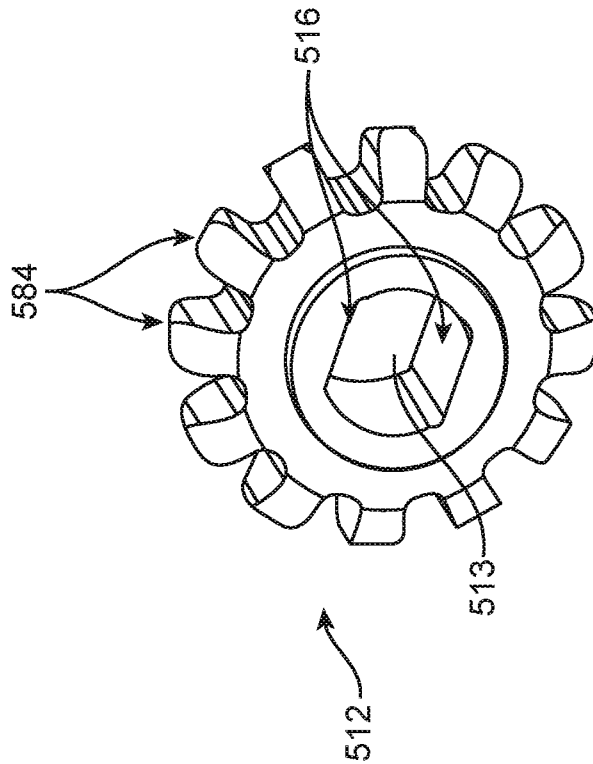

FIG. 5D

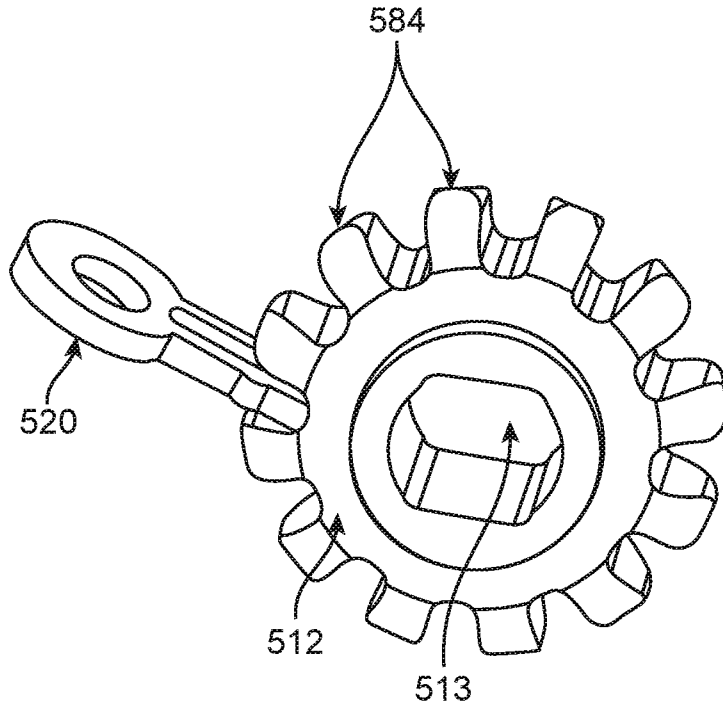

FIG. 5F

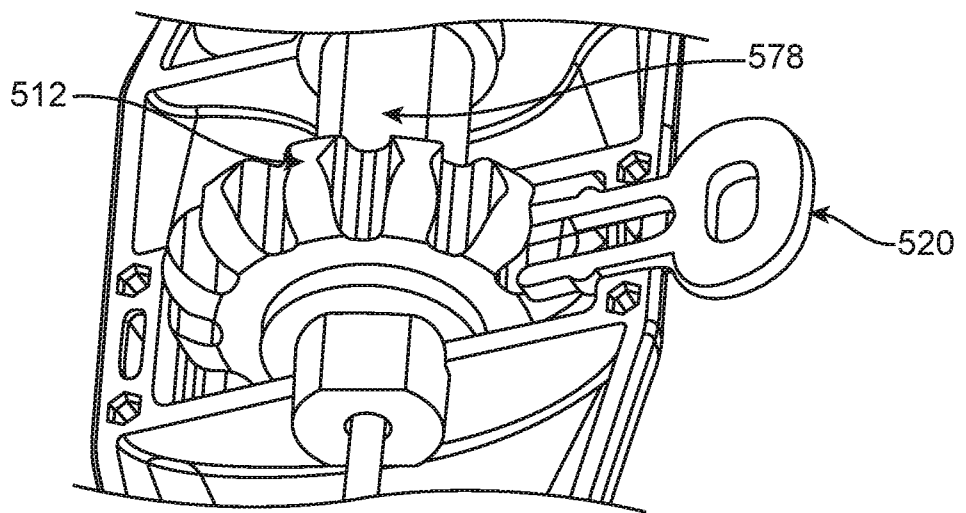

FIG. 5G

600

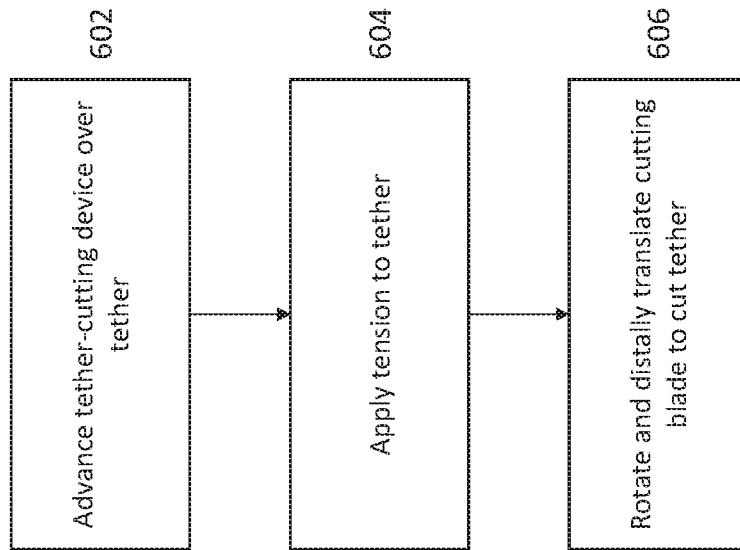

FIG. 6

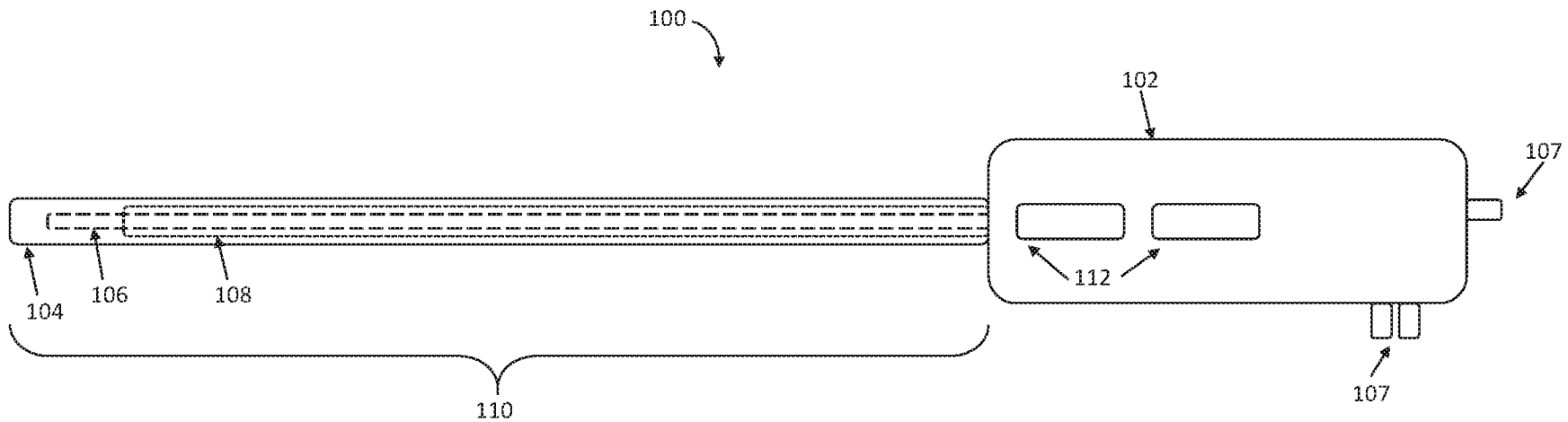

FIG. 1A