



- (51) International Patent Classification:
E21B 47/10 (2012.01)
- (21) International Application Number:
PCT/US2016/036305
- (22) International Filing Date:
8 June 2016 (08.06.2016)
- (25) Filing Language:
English
- (26) Publication Language:
English
- (30) Priority Data:
14/739,629 15 June 2015 (15.06.2015) US
15/172,335 3 June 2016 (03.06.2016) US
- (71) Applicant: **BAKER HUGHES INCORPORATED**
[US/US]; 2929 Allen Parkway, Suite 2100, Houston, Texas
77019 (US).
- (72) Inventors: **GUPTA, D.V. Satyanarayana**; 38 Webb
Creek Place, The Woodlands, Texas 77382 (US). **MUR-**
UGESAN, Sankaran; 28702 Maple Red Dr., Katy, Texas
77494 (US). **KHABASHEKU, Valery N.**; 2421B Dor-

ington Street, Houston, Texas 77030 (US). **KUZNET-**
SOV, Oleksandr; 6620 Gessner Drive, Unit 8305, Hous-
ton, Texas 77040 (US). **SURESH, Radhika**; 7115 Tied-
mann Park Way, Sugar Land, Texas 77479 (US).

(74) Agent: **JONES, John Wilson**; Jones & Smith, LLP, 2777
Allen Parkway, Suite 1000, Houston, Texas 77019 (US).

(81) Designated States (unless otherwise indicated, for every
kind of national protection available): AE, AG, AL, AM,
AO, AT, AU, AZ, BA, BB, BG, BH, BN, BR, BW, BY,
BZ, CA, CH, CL, CN, CO, CR, CU, CZ, DE, DK, DM,
DO, DZ, EC, EE, EG, ES, FI, GB, GD, GE, GH, GM, GT,
HN, HR, HU, ID, IL, IN, IR, IS, JP, KE, KG, KN, KP, KR,
KZ, LA, LC, LK, LR, LS, LU, LY, MA, MD, ME, MG,
MK, MN, MW, MX, MY, MZ, NA, NG, NI, NO, NZ, OM,
PA, PE, PG, PH, PL, PT, QA, RO, RS, RU, RW, SA, SC,
SD, SE, SG, SK, SL, SM, ST, SV, SY, TH, TJ, TM, TN,
TR, TT, TZ, UA, UG, US, UZ, VC, VN, ZA, ZM, ZW.

(84) Designated States (unless otherwise indicated, for every
kind of regional protection available): ARIPO (BW, GH,
GM, KE, LR, LS, MW, MZ, NA, RW, SD, SL, ST, SZ,
TZ, UG, ZM, ZW), Eurasian (AM, AZ, BY, KG, KZ, RU,

[Continued on next page]

(54) Title: METHODS OF USING CARBON QUANTUM DOTS TO ENHANCE PRODUCTIVITY OF FLUIDS FROM WELLS

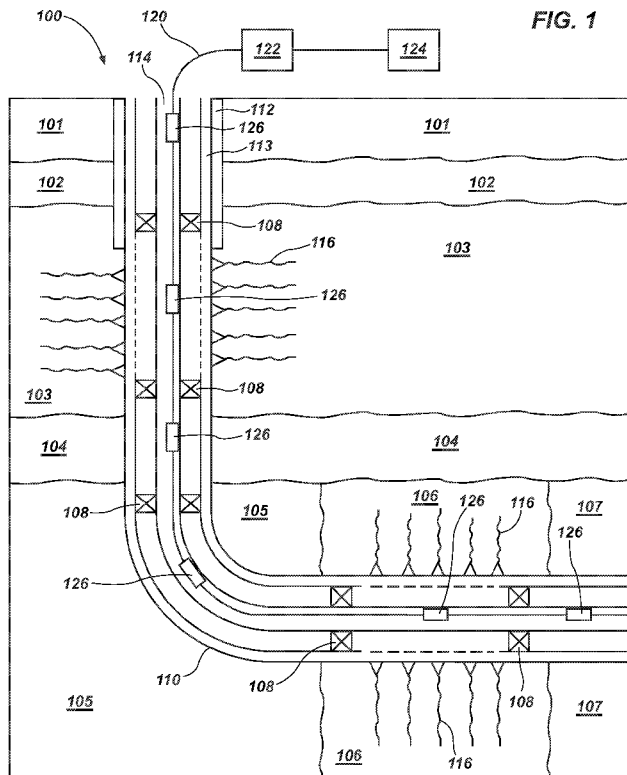

(57) Abstract: Carbon quantum dots are used as tracers dur-
ing the production of hydrocarbons. The tracer may be used
to identify fluids produced from the reservoir. When used in
the fracturing of multiple zones of the reservoir, qualitat-
ively distinguishable carbon quantum dots may be used to
identify the zone within the reservoir from which recovered
fluid was produced. The carbon quantum dots may also be
used in water flooding to determine water breakthrough in
the production well. Upon water breakthrough in a produc-
tion well, they may also be used to identify those injection
wells from which breakthrough water originates.

WO 2016/205026 A1

TJ, TM), European (AL, AT, BE, BG, CH, CY, CZ, DE, **Published:**
DK, EE, ES, FI, FR, GB, GR, HR, HU, IE, IS, IT, LT, — *with international search report (Art. 21(3))*
LU, LV, MC, MK, MT, NL, NO, PL, PT, RO, RS, SE,
SI, SK, SM, TR), OAPI (BF, BJ, CF, CG, CI, CM, GA,
GN, GQ, GW, KM, ML, MR, NE, SN, TD, TG).

TITLE: METHODS OF USING CARBON QUANTUM DOTS TO ENHANCE PRODUCTIVITY OF FLUIDS FROM WELLS

SPECIFICATION

Technical Field

[0001] Embodiments of the disclosure relate generally to methods of forming carbon quantum dots, methods and systems of using the carbon quantum dots to determine at least one property within subterranean formations and methods of using the carbon quantum dots to enhance the productivity of hydrocarbon-containing fluids from the subterranean formations.

Background

[0002] During formation and operation of a wellbore, it may be desirable to measure at least one property within a subterranean formation through which the wellbore extends. For example, a high pH may be a precursor of scale build-up and a low pH may be a precursor to corrosion of wellbore equipment. Thus, the pH of a formation fluid is conventionally monitored to aid in reducing scale build-up and potential corrosion of the wellbore equipment.

[0003] Conventionally, the pH of the formation fluid is determined by obtaining a sample of the formation fluid and analyzing the sample in a laboratory. However, as the formation fluid is brought from formation conditions (e.g., high temperature high pressure conditions), acid gases and salts may come out of solution, irreversibly changing the pH of the sample. Thus the analyzed sample may not be an accurate representation of the pH of the formation fluid at formation conditions.

[0004] Other methods of determining a pH of formation fluids include introducing a dye (e.g., phenol red, methylene blue, and/or cresol red) into the formation and correlating the pH of the formation fluid to the color of the dye. However, such dyes may not be

formulated to determine the pH of the formation fluid with a desired level of accuracy. For example, some dyes may only be sensitive within a narrow pH range, such as a pH range of about 3.0 pH units. In addition, the dyes may be chemically unstable under formation conditions. Further, a continuous pH measurement may not be obtained unless the dye is continuously injected into the subterranean formation.

[0005] Other properties of the subterranean formation (e.g., salinity, wettability of formation surfaces, flow paths through the subterranean formation, etc.) may be determined using one or more tracer compounds. For example, water tracers may be introduced into the subterranean formation to estimate flow patterns between wells during enhanced oil recovery processes, such as, for example, water flooding.

[0006] In addition to measuring at least one property within the formation through which the wellbore extends, tracers have been used in reservoir monitoring. Reservoir monitoring refers to the gathering and analysis of information from reservoirs during production. Such monitoring is used to assess the productivity of producing formations or zones within the formations from which fluids are being produced. Monitoring of produced fluids is important in order to increase efficiency of a hydraulic fracturing operation. Reservoir monitoring is further used to determine water saturation levels in the well.

[0007] In the past, produced fluids have been monitored by the use of tracers placed in packs in strategic areas within the well. See, for instance, U.S. Patent Nos. 3,991,827; 4,008,763; 5,892,147 are U.S. Patent No. 7,560,690.

[0008] Tracers may include a fluorophore (i.e., a compound that can re-emit light upon light excitation) and a presence of the tracer may be determined by optical spectroscopy (absorbance, fluorescence and phosphorescence). However, the fluorophore may include organic molecules and rare-earth complexes that are toxic and/or radioactive and may contaminate the subterranean formation (e.g., aquifers located in the subterranean formation). Further, fluorophores may decompose at downhole conditions and may be subject to photobleaching (i.e., the photochemical alteration of the fluorophore such that it becomes permanently unable to fluoresce) and photo blinking (i.e., fluorescence intermittency).

Brief Summary

[0009] Embodiments disclosed herein include systems and methods for determining at least one property of a subterranean formation. Additional embodiments disclosed herein include methods of enhancing the productivity of hydrocarbon containing fluids from a subterranean formation penetrated by a well.

[00010] For example, in accordance with one embodiment, a system for determining at least one property of at least one fluid in at least one subterranean formation comprises a fluid delivery system configured and positioned to deliver a fluid into at least one of at least one subterranean formation and a wellbore extending through the at least one subterranean formation, a radiation source within the wellbore, the radiation source configured to generate excitation radiation, carbon quantum dots disposed in the fluid, and a detector within the wellbore, the detector configured to measure at least one optical property of the carbon quantum dots.

[00011] In additional embodiments, a system for determining at least one property of at least one subterranean formation comprises at least one fiber optic cable within a wellbore extending through at least one subterranean formation, the at least one fiber optic cable including at least one optical fiber comprising carbon quantum dots, a radiation source coupled to the at least one optical fiber, the radiation source configured to generate excitation radiation for transmission through the at least one optical fiber, and a detector coupled to the at least one fiber optic cable, the detector configured to measure at least one optical property of the carbon quantum dots.

[00012] In further embodiments, a method of forming carbon quantum dots comprises providing an electrolyte comprising a carbon source and a source of ions to an electrochemical cell, introducing the electrolyte between platinum electrodes of the electrochemical cell, and applying electrical current between the platinum electrodes to form carbon quantum dots including carbon from the carbon source.

[00013] In further embodiments, a method of determining at least one property within at least one subterranean formation comprises introducing at least one fiber optic cable into at least one of at least one subterranean formation and a wellbore extending into the at least one subterranean formation, transmitting excitation radiation through the at least one fiber optic cable from a radiation source coupled to the at least one fiber optic cable, exposing carbon quantum dots disposed in a fluid in the wellbore or on the at least one fiber optic cable to the excitation radiation, receiving, at an optical sensor coupled to the at least one fiber optic cable, an emitted radiation from the carbon quantum dots responsive to exposure of the carbon quantum dots to the excitation radiation, and measuring at least one of an emission spectrum and a fluorescence intensity of the emitted radiation at a detector coupled to the at least one fiber optic cable.

[00014] In additional embodiments, a method of fracturing multiple zones of a subterranean formation penetrated by a well comprises: (a) pumping into each zone of the formation to be fractured a fracturing fluid, wherein the fracturing fluid pumped

into each zone comprises a qualitatively distinguishable tracer comprising carbon quantum dots which are either hydrocarbon soluble, water soluble or both hydrocarbon soluble and water soluble; (b) enlarging or creating a fracture in the formation; (c) recovering fluid from at least one of the multiple zones; and (d) identifying the zone within the subterranean formation from which the recovered fluid was produced by identifying the carbon quantum dots in the recovered fluid.

[00015] In other embodiments, a method of monitoring the production of fluids produced in multiple productive zones of a subterranean formation penetrated by a well comprises: (a) pumping fracturing fluid into the multiple productive zones at a pressure sufficient to enlarge or create fractures in each of the multiple productive zones, wherein the fracturing fluid comprises optically active carbon quantum dots which are either hydrocarbon soluble, water soluble or both hydrocarbon soluble and water soluble and further wherein the fluorescent carbon quantum dots pumped into each of the multiple productive zones is qualitatively and/or quantitatively distinguishable; and (b) monitoring the amount of fluids produced from at least one of the multiple productive zones from the carbon quantum dots in the produced fluid.

[00016] In other embodiments, a method for enhancing the production of hydrocarbons from a production well penetrating a hydrocarbon-bearing formation, wherein one or more injector wells are associated with the production well, comprises: (a) introducing into one or more of the injector wells an aqueous fluid comprising fluorescent carbon quantum dots; (b) flowing at least a portion of the aqueous fluid comprising the optically active carbon quantum dots from the one or more injector wells into the production well; and (c) recovering hydrocarbons from the production well.

[00017] In yet other embodiments, a method for determining water breakthrough in a production well associated with one or more injector wells, comprises: (a) injecting an aqueous fluid comprising optically active carbon quantum dots as tracer into an injector well; (b) flowing the aqueous fluid from the injector well into the production well; (c) producing fluid from the production well; and (d) determining water breakthrough in the production well by qualitatively determining the presence or quantitatively measuring the amount of the fluorescent carbon quantum dots in the produced fluid.

[00018] In still other embodiments, a method of increasing hydrocarbon production from a production well penetrating a hydrocarbon-bearing reservoir, wherein more

than one injection well is associated with the production well, comprises: (a) injecting an aqueous fluid having a water soluble tracer comprising carbon quantum dots into the more than one injection well and maintaining pressure in the hydrocarbon-bearing reservoir above the bubble point of the hydrocarbons in the reservoir, wherein the aqueous fluid pumped into each of the injection wells contains qualitatively distinguishable carbon quantum dots; (b) identifying from hydrocarbons recovered from the production well, upon water breakthrough in the production well, the injection well into which the breakthrough water was injected by qualitatively determining the presence of the carbon quantum dots in the recovered hydrocarbons; and (c) shutting off the injector well identified in step (b).

Brief Description of the Drawings

[00019] FIG. 1 is a simplified schematic illustrating a system including a wellbore within a subterranean formation, in accordance with embodiments of the disclosure;

[00020] FIG. 2A is a simplified cross-sectional view illustrating a fiber optic cable, in accordance with embodiments of the disclosure;

[00021] FIG. 2B is a simplified cross-sectional view of the fiber optic cable taken along line B-B of FIG. 2A;

[00022] FIG. 2C is a simplified cross-sectional view of another fiber optic cable, in accordance with embodiments of the disclosure;

[00023] FIG. 2D is a simplified cross-sectional view illustrating a fiber optic cable, in accordance with other embodiments of the disclosure;

[00024] FIG. 2E is a simplified schematic illustrating a measuring system including a fluid delivery system, in accordance with yet other embodiments of the disclosure;

[00025] FIG. 3A is a graph illustrating an absorption spectrum, an excitation spectrum, and an emission spectrum of carbon quantum dots, in accordance with embodiments of the disclosure;

[00026] FIG. 3B is a graph illustrating a change in intensity and a change in wavelength as a function of pH for carbon quantum dots exposed to an excitation radiation having a substantially monochromatic wavelength, in accordance with embodiments of the disclosure; and

[00027] FIG. 4 is a simplified cross-sectional view of an electrochemical cell for forming carbon quantum dots, in accordance with embodiments of the disclosure.

Detailed Description

[00028] The following description provides specific details, such as material types, compositions, and processing conditions in order to provide a thorough description of embodiments of the disclosure. However, a person of ordinary skill in the art will understand that the embodiments of the disclosure may be practiced without employing these specific details. Indeed, the embodiments of the disclosure may be practiced in conjunction with conventional techniques employed in the industry. In addition, the description provided below does not form a complete process flow for measuring properties within a subterranean formation or for forming carbon quantum dots. Only those process acts and structures necessary to understand the embodiments of the disclosure are described in detail below.

[00029] As used herein, the term “optical property” means and includes any qualitative or quantitative property relating to optically active carbon quantum dots (CQDs) which may be determined by optical spectroscopy (such as absorbance, fluorescence and phosphorescence). As non-limiting examples, optical properties include a wavelength at which a material exhibits a peak absorption intensity, a wavelength at which a material exhibits a peak fluorescence intensity (e.g., a color of light emitted during fluorescence, such as when the fluorescence is in the visible spectrum), an excitation spectrum, an emission spectrum, an intensity of absorbed electromagnetic radiation, and an intensity of emitted electromagnetic radiation. The electromagnetic radiation may be anywhere within the electromagnetic spectrum, including, for example, the UV spectrum, the visible spectrum, and the infrared (IR) spectrum.

[00030] According to embodiments disclosed herein, a method of forming carbon quantum dots (CQDs) includes providing an electrochemical cell including an electrolyte comprising a carbon source, water, and at least another material. A current is applied across electrodes of the electrochemical cell to form carbon quantum dots comprising carbon from the carbon source. The carbon source may include at least one of (i.e., one or more of) nitrogen, boron, silicon, and phosphorus to form at least one of nitrogen-doped, boron-doped, silicon-doped, and phosphorus-doped carbon quantum dots, respectively. The carbon quantum dots may be water soluble, exhibit unique optical properties depending on a size and chemical composition (e.g., doping) of the carbon quantum dots, may be stable at wide pH ranges and temperatures (e.g., up to about 400°C), and may be resistant to photobleaching and photo blinking. Surfaces of the carbon quantum dots may

be functionalized to form exposed hydrophilic surfaces, exposed hydrophobic surfaces, or exposed amphiphilic surfaces on the carbon quantum dots.

[00031] The optical properties of carbon quantum dots may be used to determine at least one property of at least one subterranean formation penetrated by a well (e.g., a pH of the formation fluid, a wettability of formation surfaces, a production zone within the at least one subterranean formation, an injection well contributing to the flow of breakthrough water, etc.). For example, the carbon quantum dots may exhibit an optical property that is related to a pH to which the carbon quantum dots are exposed.

[00032] Carbon quantum dots thus may be introduced into the subterranean formation penetrated by a well and exposed to excitation radiation (e.g., an excitation wavelength), such as fluorescence.

[00033] The well may be an oil well, gas well, water well or a geothermal well.

[00034] The radiation source may be located within the wellbore and may be configured to provide the excitation radiation to the carbon quantum dots disposed within the fluid and be configured to measure at least one optical property of the carbon quantum dots. For example, a radiation source (e.g., a light source) may be coupled to a fiber optic cable, which may transmit the excitation radiation to the carbon quantum dots. The carbon quantum dots may be disposed within at least one optical fiber of the fiber optic cable or may be coated onto at least a portion of the at least one optical fiber. Responsive to exposure to the excitation radiation, the carbon quantum dots may fluoresce (e.g., re-emit radiation at a different wavelength than the excitation wavelength).

[00035] The emitted radiation may be transmitted through the at least one optical fiber to a detector that may be configured to measure at least one optical property of the carbon quantum dots.

[00036] The detection source may further be located above the wellbore. For instance, the source may be on the fly or at an external location distant from the wellbore.

[00037] In some embodiments, the carbon quantum dots are disposed in a fluid within the wellbore. In one embodiment, the carbon quantum dots may be introduced or pumped into a well as neutrally buoyant particles in the carrier fluid.

[00038] A fluid delivery system may be configured to provide (e.g., deliver) the carbon quantum dots to the wellbore. The carbon quantum dots are compatible with fluids naturally present in the reservoir and within the rock itself. In addition, the carbon quantum dots are compatible with the fluids injected into the reservoir as part of the formation treatment. Further, the carbon quantum dots must be susceptible to being

readily detected qualitatively and analyzed quantitatively in the presence of the materials in the formation fluids.

[00039] The carbon quantum dots may be used to identify fluids produced from the well. Since the carbon quantum dots may be detected in recovered produced fluids, the methods described herein thus do not require downhole equipment for detection. Typically, fluids transported out of the well are evaluated and the carbon quantum dots are identified on the fly or at a location distant from the wellbore.

[00040] In addition, the carbon quantum dots may be used as tracers to monitor fluid flow through the subterranean formation. For example, carbon quantum dots exhibiting different optical properties may be introduced into different zones (e.g., producing zones, aquifer zones, etc.) of the subterranean formation. A produced fluid exhibiting an optical property, such as fluorescence, corresponding to a property of carbon quantum dots introduced into a zone of the subterranean zone may be an indication that the produced fluid originated from the zone in which the carbon quantum dots were introduced.

[00041] The carbon quantum dots may also be used to sweep a production well in an enhanced oil recovery (EOR) operation, such as flooding. Carbon quantum dots may be introduced into injection fluid and the injection fluid introduced into the formation. The injection fluid may be introduced by being pumped into one or more injection wells. Typically, the carbon quantum dots are soluble in the injection fluid.

[00042] Injection fluids transporting carbon quantum dots into the formation are typically aqueous based, such as a brine, like a saturated potassium chloride or sodium chloride brine, salt water such as seawater, fresh water, a liquid hydrocarbon, a surfactant or a gas such as nitrogen or carbon dioxide. The carbon quantum dots may further be injected into the formation in liquefied gas, such as liquefied natural gas or liquefied petroleum gas as well as in foams, such as carbon dioxide, nitrogen and carbon dioxide/nitrogen. The injection fluid is preferably aqueous, steam or gas (water flooding, steam flooding or gas flooding).

[00043] The detection of the carbon quantum dots in fluids produced from the production well is indicative that the sweep, i.e., removal of the oil from pore spaces within the formation, has been completed.

[00044] Injection fluid pumped into the production well at different locations may contain qualitatively and/or quantitatively different carbon quantum dots. For instance, different carbon quantum dots, distinguishable from each other, may be introduced in an aqueous fluid into different injection wells. Fluids produced from

the well may be analyzed to determine if water breakthrough has occurred in the production well. By using different carbon quantum dots in different fluids, the injection well from which the water in the breakthrough water was pumped may be determined by optical spectroscopy. The injection well, into which the water in the breakthrough water has been determined to have been initially introduced, can be shut off. Thus, the carbon quantum dots can be used to optimize enhancement of hydrocarbons during secondary recovery operations by shutting down the injection well feeding into the formation into which sweep efficiency has been maximized. Thus, the flow of water from the injection well into that portion of the formation having been completely swept may be terminated.

[00045] Generally, fluids pumped into the production well do not require excessive amounts of the carbon quantum dots. Typically, the minimum amount of carbon quantum dots in the fluid introduced into the formation, the production well or injection well is that amount sufficient to permit detection within a produced fluid. Typically, the amount of carbon quantum dots present in the introduced fluid is between from about 1 ppm to about 500,000 ppm.

[00046] In some embodiments, a mixture of hydrophilic and hydrophobic carbon quantum dots exhibiting different optical properties may be introduced into the subterranean formation, into the production well or into one or more injection wells.

[00047] A ratio of hydrophilic carbon quantum dots to hydrophobic carbon quantum dots in a produced fluid may be determined by an optical property of the produced fluid. The ratio may be employed as an indication of a wettability of surfaces of the subterranean formation (e.g., a ratio of water wet surfaces to oil wet surfaces in the subterranean formation). It may also be indicative of the productivity of particular zones within the formation.

[00048] FIG. 1 is a simplified schematic illustration of a wellbore system 100 extending through one or more subterranean formations. The subterranean formations may include a plurality of zones, including a first zone 101 proximate a surface of the earth, an aquifer zone 102 below the first zone, a second zone 103 below the aquifer zone 102, a third zone 104 below the second zone 103, a fourth zone 105 below the third zone 104, and a fifth zone 106 horizontally adjacent to the fourth zone 105. The subterranean formation may include one or more additional zones, such as a sixth zone 107 horizontally adjacent to the fifth zone 106. At least some of the zones may be hydrocarbon-bearing zones. For example, the second zone 103 and the fifth zone 106 may be hydrocarbon-bearing zones

and may include fractures 116 through which hydrocarbons to be produced may travel during production. The other zones (e.g., the third zone 104, the fourth zone 105, and the sixth zone 107) may also contain hydrocarbons. Each of the zones may be isolated from other zones by at least one packer 108.

[00049] A wellbore 110 may extend through each of the different zones of the subterranean formation. Cement 112 may line the wellbore 110 at least through the first zone 101, the aquifer zone 102, and at least a portion of the second zone 103. A liner string 113 may line at least a portion of the wellbore 110. A production string 114 may extend through the subterranean formation and to a portion of the formation bearing hydrocarbons to be produced.

[00050] During formation and operation of the wellbore 110 (e.g., during drilling, completion, stimulation, production, etc.), it may be desirable to measure or estimate properties of fluids (e.g., drilling fluids, stimulation fluids, completion fluids, formation fluids, injection fluids, produced fluids etc.) located within the wellbore 110 and/or subterranean formation through which the wellbore 110 extends. Further, it may be desirable to determine the productivity of the zones within the formation they have been subjected to fracturing in a multi-zone fracturing operation, water breakthrough in fluids produced from the formation, sweep efficiency, etc. Such properties may be measured in real time.

[00051] Thus, as will be described in more detail below, at least one optical property, such as at least one of (i.e., one or more of) an absorption spectrum, an absorption intensity, a peak absorption wavelength, an emission spectrum, a peak emission wavelength, and a fluorescence intensity of carbon quantum dots, may be related to the determination of at least one property of at least one subterranean formation as referenced herein. In addition, the at least one optical property may identify one or more injection wells from which water has been introduced into a production well, etc..

[00052] The carbon quantum dots may be formulated to exhibit unique optical properties associated with the size and the molecular composition of the carbon quantum dots. Carbon quantum dots which are qualitatively distinguishable by detection means and/or quantitatively distinguishable by detection means may be used. For instance, in the production of produced fluids from a formation, a first group of carbon quantum dots and at least a second group of carbon quantum dots may be used; the first group of carbon quantum dots formulated to exhibit a different detection property than the at least a second group of carbon quantum dots. At least one group of carbon quantum dots may be soluble in water and at least one other group of carbon quantum dots may

be soluble in hydrocarbon. Alternatively, both groups may be soluble in hydrocarbon or water.

[00053] The carbon quantum dots may be formulated to fluoresce at wavelengths corresponding to a color of the visible spectrum (e.g., violet, blue, cyan, green, yellow, orange, and red). The color of fluorescence may depend at least in part upon at least one of a size and a chemical composition of the carbon quantum dots. In some embodiments, the carbon quantum dots may be formulated to exhibit upconversion properties. For example, in some embodiments, the carbon quantum dots may be formulated to emit radiation at a shorter wavelength (and a corresponding higher energy) than radiation absorbed by the carbon quantum dots.

[00054] Accordingly, carbon quantum dots may be introduced into the subterranean formation at a zone where it is desired to determine the pH of a fluid within the wellbore (e.g., formation fluid). In some embodiments, the carbon quantum dots comprise a part of at least one optical fiber (e.g., the carbon quantum dots may comprise a coating on an optical fiber or the carbon quantum dots may be disposed within the optical fiber). The optical fiber including the carbon quantum dots may be exposed to fluid in communication with the subterranean formation.

[00055] In other embodiments, the carbon quantum dots are introduced into the subterranean formation with a fluid delivery system configured to deliver a fluid having the carbon quantum dots suspended therein to the subterranean formation.

[00056] In other embodiments, the carbon quantum dots are introduced into one or more injection wells in a fluid delivery system configured to deliver a fluid into the injection well and to maintain pressure within the wellbore above the bubble point of fluids being extracted from the formation.

[00057] The pH of a fluid within the wellbore 110 may be determined by exposing the carbon quantum dots disposed within the wellbore 110 to an excitation radiation and measuring at least one of (i.e., one or more of) the absorption spectrum, the absorption intensity, the peak absorption wavelength (i.e., the peak of the absorption spectrum), the emission spectrum, the peak emission wavelength (i.e., the peak of the emission spectrum), and the fluorescence intensity of the carbon quantum dots responsive to exposure to the excitation radiation. The excitation radiation may be at a substantially monochromatic wavelength or may be at a plurality of wavelengths (i.e., polychromatic wavelengths).

[00058] With continued reference to FIG. 1, the wellbore system 100 may include a fiber optic cable 120 extending from a surface location of the subterranean formation to locations adjacent to one or more zones within the subterranean formation. The fiber optic

cable 120 may extend along an interior of the production string 114, similar to a wireline, as is known to those of ordinary skill in the art, and may be run into the production string 114 as desired, or permanently deployed within the production string 114. Although the fiber optic cable 120 is illustrated as extending along an interior of the production string 114, the fiber optic cable 120 may be located at any suitable location within the wellbore system 100 relative to the production string 114. For example, the fiber optic cable 120 may be run along an exterior of the production string 114, or comprise part of a self-contained sensor package configured for wireless communication, as noted below.

[00059] The fiber optic cable 120 may be coupled to a radiation source 122 and to a detector 124. In some embodiments, the radiation source 122 and the detector 124 may be located at the surface above the subterranean formation, such as on or adjacent to the rig floor. As will be described herein, in other embodiments, one or more of the radiation source 122 and the detector 124 may be located within the wellbore 110. The radiation source 122 may be configured to emit electromagnetic radiation at one or more wavelengths (i.e., the excitation radiation) which may be transmitted through the fiber optic cable 120 to one or more locations within the subterranean formation. In some embodiments, the radiation source 122 comprises a laser configured to transmit the excitation radiation at a substantially monochromatic (e.g., a substantially fixed and uniform) wavelength. The substantially monochromatic wavelength may be any wavelength in the electromagnetic spectrum. In some embodiments, the substantially monochromatic wavelength may be within the ultraviolet spectrum, such as, for example, between about 100 nm and about 400 nm. In other embodiments, the radiation source 122 includes a broadband radiation source configured to provide the excitation radiation at more than one wavelength (e.g., polychromatic wavelengths). By way of non-limiting example, the radiation source 122 may include a light-emitting diode (LED) (e.g., a collimated LED, an uncollimated LED), a xenon lamp, a mercury lamp, or other suitable electromagnetic radiation source. In some embodiments, the excitation radiation is transmitted in pulses.

[00060] The fiber optic cable 120 may include one or more optical sensors 126 configured to detect one or more fluorescence properties of the carbon quantum dots in the wellbore system 100. FIG. 2A is a simplified schematic representation of a fiber optic cable 120 including an optical sensor 126. The fiber optic cable 120 may include at least one optical fiber 128 within a sheath 132 configured to transmit the excitation radiation to the carbon quantum dots within the wellbore 110 and at least one optical fiber 130 within the sheath 132 configured to receive the radiation emitted from the carbon quantum dots. Each of the optical fibers 128 may be coupled to the radiation source 122

(FIG. 1) and each of the optical fibers 130 may be coupled to the detector 124 (FIG. 1). The optical sensor 126 may include at least one exposed portion of the optical fiber 128 and at least one exposed portion of the optical fiber 130.

[00061] Each of the optical fibers 128 may be configured to receive the excitation radiation independently of other optical fibers 128 and at differing wavelengths, intensities and, if applicable, pulse rates, radiation pulses from different optical fibers 128 being sent simultaneously or at offset time intervals. In other embodiments, each of the optical fibers 128 may be configured to receive excitation radiation of substantially the same wavelength, intensity and, if applicable, pulse rates and intervals as the other optical fibers 128. In yet other embodiments, the radiation source 122 may be configured to provide the excitation radiation at a substantially monochromatic wavelength and intensity to one of the optical fibers 128 and excitation radiation of another substantially monochromatic wavelength and intensity to another of the optical fibers 128.

[00062] A distal end of the optical fiber 128 may include what is known in the art as a “mirror finished” or a “polished” end 134. The mirror finished ends 134 of the optical fibers 128 may be angled with respect to a longitudinal axis of the optical fiber 128 and may be configured to reduce undesired reflection and/or scattering of the excitation radiation. For example, the mirror finished end 134 may be configured to reduce attenuation of the excitation radiation to be received through the optical fibers 130. The mirror finished ends 134 may be configured to substantially reflect light emitted by the carbon quantum dots to the detector 124.

[00063] At least a portion of at least one optical fiber 128 may include carbon quantum dots 129 disposed therein. The carbon quantum dots 129 may be disposed within one or more optical fibers. FIG. 2B is a simplified cross-sectional view of the fiber optic cable 120 of FIG. 2A. The carbon quantum dots 129 may be disposed within and integral with the optical fibers 128. By way of non-limiting example, carbon quantum dots 129 may be dispersed in a composition (e.g., mixed in a molten solution) from which the optical fibers 128 are formed (e.g., extruded, drawn, cast, etc.). It is contemplated that, in some embodiments, the optical fibers 128 may include materials formulated to enhance optical properties of the optical fibers 128, such as, for example, titanium dioxide.

[00064] Portions of the optical fibers 128 may be exposed to a wellbore fluid 140 (e.g., drilling fluids, stimulation fluids, completion fluids, formation fluids, etc.). For example, at least a distal end of the optical fibers 128 may be exposed to the wellbore fluid 140. The portions of the optical fibers 128 that are exposed to the wellbore fluid

140 may include the carbon quantum dots 129 disposed therein. The excitation radiation from the radiation source 122 may be transmitted to the carbon quantum dots 129 of the optical fibers 128. Responsive to exposure to the excitation radiation, the carbon quantum dots 129 may emit radiation exhibiting at least one fluorescence property related to the pH of the formation fluid 140 surrounding the exposed portions of the optical fibers 128. The optical fiber 130 may receive the radiation emitted by the carbon quantum dots 129 and transmit the emitted radiation to the detector 124.

[00065] In other embodiments, the carbon quantum dots 129 may be disposed on at least one surface of at least one optical fiber. For example, a surface of at least one optical fiber may have a coating of the carbon quantum dots. FIG. 2C is a simplified cross-sectional view of a fiber optic cable 120' substantially similar to the fiber optic cable 120 of FIG. 2B, except that the fiber optic cable 120' includes optical fibers 128' having a coating 127 of carbon quantum dots thereon. In some embodiments, the coating 127 comprises a monolayer of carbon quantum dots. The coating 127 may substantially surround each of the optical fibers 128'. The coating 127 may be a substantially continuous layer around an entire circumference of each of the optical fibers 128'. The coating 127 may be in contact with the wellbore fluid 140, which may affect at least one fluorescence property of the carbon quantum dots of the coating 127.

[00066] The coating 127 may be located at, for example, the distal end of the optical fiber 128'. The excitation radiation from the radiation source 122 may be transmitted to the carbon quantum dots on the coating 127. Responsive to exposure to the excitation radiation, the carbon quantum dots may emit radiation exhibiting at least one fluorescence property related to the pH of the wellbore fluid 140 surrounding the coating 127.

[00067] The optical fibers 130 may be configured to receive the radiation emitted by the carbon quantum dots (e.g., radiation emitted from the coating 127) and transmit the emitted radiation to the detector 124, which may be located at a surface location. Each of the optical fibers 130 may be coupled to the detector 124.

[00068] Accordingly, in some embodiments, the carbon quantum dots may be introduced into the subterranean formation with the fiber optic cable 120, 120'. Radiation emitted by the carbon quantum dots on or within the optical fibers 128, 128' may be received by the optical fiber 130 and transmitted to the detector 124. Thus, the carbon quantum dots may be configured to continuously measure the pH of the fluid in the wellbore 110 without continuously introducing new carbon quantum dots into the subterranean formation.

[00069] In other embodiments, the carbon quantum dots may not be coated on the optical fibers 128, 128', but may be disposed in the wellbore fluid 140. FIG. 2D illustrates an embodiment of another fiber optic cable 120" according to another embodiment of the disclosure. The fiber optic cable 120" may include an optical sensor 126' comprising optical fibers 128" configured to transmit excitation radiation to carbon quantum dots disposed within the wellbore 110 and at least one optical fiber 130 within the sheath 132 configured to receive the radiation emitted from the carbon quantum dots. The carbon quantum dots may be disposed in the wellbore fluid 140 proximate the optical fibers 128", 130. The concentration of the carbon quantum dots in the wellbore fluid 140 may be between about 50 parts per trillion (ppt) and about 10,000 parts per million (ppm), such as between about 50 ppt and about 500 ppt, between about 500 ppt and about 5,000 ppt (5 ppm), between about 5 ppm and about 500 ppm, or between about 500 ppm and about 10,000 ppm.

[00070] Excitation radiation may be transmitted through the optical fibers 128" to the carbon quantum dots in the wellbore fluid 140. Responsive to exposure to the excitation radiation, the carbon quantum dots may emit radiation that may be received by the optical fibers 130. The optical fiber 130 may transmit the emitted radiation to the detector 124. Thus, a pH of the fluid 140 proximate the optical fibers 128", 130 may be determined by disposing the carbon quantum dots in the wellbore fluid 140 and detecting at least one fluorescence property of the carbon quantum dots.

[00071] Accordingly, with reference again to FIG. 1, the radiation source 122 may be configured to pulse the excitation radiation to the carbon quantum dots within the wellbore 110. Carbon quantum dots proximate one or more of the optical sensors 126 may absorb the excitation radiation. Responsive to absorbing the excitation radiation, the carbon quantum dots may fluoresce at an emission wavelength (e.g., that may correspond to, for example, red light, yellow light, blue light, etc.). During fluorescence, the carbon quantum dots may re-emit radiation at a wavelength (i.e., an emission wavelength) that is different from the wavelength of the excitation radiation (i.e., the excitation wavelength).

[00072] The detector 124 may be configured to continuously measure at least one fluorescence property (e.g., one or more of the absorption spectrum, the peak absorption wavelength, the absorption intensity, the emission spectrum, the peak emission wavelength, and the fluorescence intensity) of the carbon quantum dots. The measured fluorescence property may be correlated to a pH of the formation fluid. Accordingly, the pH of the formation fluid may be measured *in situ* and in real time. The detector 124 may include or be coupled to a processor configured to estimate the pH of the formation fluid based on

one or more of the absorption spectrum, the peak absorption wavelength, the absorption intensity, the emission spectrum, the peak emission wavelength, and the fluorescence intensity of the carbon quantum dots. In some embodiments, the detector is a spectrometer, such as a fluorescence spectrometer.

[00073] Although FIG. 2A through FIG. 2D illustrate optical fibers 128, 128', 128" configured to transmit the excitation radiation to the carbon quantum dots and optical fibers 130 configured to transmit the emitted radiation to the detector 124, it is contemplated that in some embodiments, the fiber optic cable 120 may include a single optical fiber. Excitation radiation may be transmitted through the optical fiber in pulses, such as every millisecond, every 10 milliseconds, or every 100 milliseconds. The fluorescence emitted by the carbon quantum dots may be transmitted back through the single optical fiber between excitation pulses and received by the detector 124. In other words, the excitation pulses may be separated in time such that the carbon quantum dots may fluoresce and the emitted fluorescent radiation may be measured at the detector 124 in between consecutive pulses of excitation radiation. Although FIG. 1 illustrates only one fiber optic cable 120 extending into the wellbore 110, the wellbore system 100 may include a plurality of fiber optic cables 120 extending into the wellbore 110. For example, in some embodiments, at least one fiber optic cable 120 may be configured to transmit the excitation radiation to the carbon quantum dots and at least one fiber optic cable 120 may be configured to receive and transmit the emitted radiation from the carbon quantum dots to the detector 124.

[00074] Although the radiation source 122 and the detector 124 are illustrated as being located at a surface location of the subterranean formation, at least one of the radiation source 122 and the detector 124 may be located within the wellbore 110. FIG. 2E is a simplified schematic illustrating a measuring system 150 according to another embodiment of the disclosure. The measuring system 150 includes a fluid deliver system 152 configured and positioned to deliver a carbon quantum dot-containing fluid 154 into the wellbore 110, such as into the production string 114. The radiation source 122 and the detector 124 may be located at a location downstream of the fluid deliver system 152. The wellbore fluid 140 may flow in the production string 114 in the direction indicated by arrow 156. The wellbore fluid 140 may carry the carbon quantum dot-containing fluid 154 to a location proximate the radiation source 122 and the detector 124. In some embodiments, the fluid delivery system 152 is located proximate the radiation source 122 and the detector 124, such as, for example, within about one meter of the radiation source 122 and the detector 124. The carbon quantum dot-containing

fluid 154 may substantially mix with the wellbore fluid 140 prior to being exposed to excitation radiation 160 from the radiation source 122.

[00075] As the carbon quantum dots in the carbon quantum dot-containing fluid 154 are exposed to the excitation radiation 160 from the radiation source 122, the carbon quantum dots may fluoresce. Responsive to exposure to the excitation radiation 160, the carbon quantum dots may emit radiation that may be received by the detector 124, which, in some embodiments, may be located directly across from the radiation source 122. In other embodiments, the detector 124 may be located adjacent the radiation source 122, such that the carbon quantum dots pass the detector 124 directly after exposure to the excitation radiation 160. Accordingly, a pH of the wellbore fluid 140 may be determined by disposing the carbon quantum dots into the wellbore fluid 140 (e.g., via the carbon-quantum dot-containing fluid 154) and detecting at least one fluorescence property of the carbon quantum dots.

[00076] The detector 124 may be configured to transmit information about the detected fluorescence properties to the surface, such as by, for example, a wire 158 coupled to the detector 124 and configured to transmit the data to the surface, wireless communications, mud pulse telemetry, or other method suitable to transmit the data from the detector 124 located within the wellbore 110 to the surface of the subterranean formation.

[00077] FIG. 3A illustrates an example of an absorption spectrum 202, an excitation spectrum 204, and an emission spectrum 206 of fluorescence of carbon quantum dots in a solution. The absorption spectrum 202 (y-axis of the absorption spectrum 202 illustrated on the left side of FIG. 3A) graphs the absorption intensity of the carbon quantum dots as a function of an excitation wavelength to which the carbon quantum dots are exposed. The peak absorption intensity occurs at a wavelength of approximately 275 nm. The excitation spectrum 204 (y-axis of the excitation spectrum 204 illustrated on the right side of FIG. 3A) graphs a radiation intensity of the excitation radiation as a function of the wavelength. The peak excitation intensity occurs at an excitation wavelength of approximately 355 nm. Although the excitation spectrum 204 is illustrated as shifted from the absorption spectrum 202, in some embodiments, the excitation spectrum 204 may be more closely aligned with the absorption spectrum 202. The emission spectrum 206 (y-axis of the emission spectrum 206 illustrated on the right side of FIG. 3B) graphs an intensity of the emitted fluorescence radiation emitted by the carbon quantum dots as a function of wavelength. The emission spectrum 206 illustrates that the peak fluorescence intensity occurs at an emission wavelength of approximately 480 nm (i.e., an emission of blue-colored light). The intensity

of the peak emission wavelength of the emission spectrum 206 may increase or decrease, depending upon the pH of the solution in which the carbon quantum dots are disposed. Thus, the carbon quantum dots are exposed to excitation radiation at a substantially monochromatic wavelength and the wavelength of the peak emitted radiation (i.e., the wavelength of the peak fluorescence intensity) is shifted from the peak wavelength of the excitation radiation.

[00078] As described above, the absorption spectrum and the emission spectrum emitted by the carbon quantum dots may depend on a pH of the solution in which the carbon quantum dots are disposed. Thus, for the same excitation wavelength, a change in the pH of the formation fluid in which the carbon quantum dots are disposed may correspond to a change in one or more of the absorption spectrum, the corresponding peak absorption wavelength of excitation radiation absorbed by the carbon quantum dot, the emission spectrum, and the corresponding peak emission wavelength emitted by the carbon quantum dots.

[00079] FIG. 3B illustrates a change in intensity (e.g., one or more of an absorption intensity and an emission intensity) and a change in wavelength (e.g., a change in one or more of an excitation wavelength and an emission wavelength) as a function of pH for carbon quantum dots exposed to an excitation radiation at a substantially monochromatic wavelength. As illustrated in FIG. 3B, at a substantially monochromatic wavelength, the intensity of the carbon quantum dots (e.g., at the wavelength at which the carbon quantum dots exhibit the most fluorescence) may depend upon a pH of the solution in which the carbon quantum dots are disposed. Similarly, a wavelength at which carbon quantum dots absorb excitation radiation and an emission wavelength of the carbon quantum dots may change based on the pH to which the carbon quantum dots are exposed. Accordingly, in some embodiments, for a substantially monochromatic excitation wavelength, a pH of a formation fluid may be estimated based at least in part on one or more fluorescence or absorption properties of the carbon quantum dots, such as, for example, the absorption intensity (e.g., a change in the absorption intensity), the fluorescence intensity (e.g., a change in the fluorescence intensity), a change in the absorption wavelength (e.g., a change in the wavelength at which a highest intensity of excitation radiation is absorbed), a change in the emission radiation wavelength (e.g., a change in the wavelength at which a highest fluorescence intensity occurs), and combinations thereof. For example, at a substantially monochromatic wavelength, the emission radiation wavelength of the carbon quantum dots may shift depending on the pH of the solution in which the carbon quantum dots are disposed.

[00080] Hydrocarbons within the subterranean formation may include materials that fluoresce responsive to exposure to the excitation radiation. Fluorescence of such materials may undesirably increase noise in at least one of the fluorescence properties measured by the detector 124. However, such materials may have a shorter fluorescence lifetime than a fluorescence lifetime of the carbon quantum dots. In some embodiments, the detector 124 may be configured to measure the at least one fluorescence property of the carbon quantum dots after a time delay, such as in time-resolved fluorometric detection. Measuring the fluorescence of the carbon quantum dots after a time delay may reduce background noise caused by fluorescence of the materials in the hydrocarbons and increase the signal-to-noise ratio of the detector 124. The time delay may be between about 1 picosecond (ps) and about 100 microseconds (μ s), such as between about 1 picosecond and about 1 nanosecond, between about 1 nanosecond and about 100 nanoseconds, between about 100 nanoseconds and about 1 microsecond, between about 1 microsecond and about 10 microseconds, or between about 10 microseconds and about 100 microseconds.

[00081] Accordingly, a fluid introduced into the subterranean formation may include the carbon quantum dots, or the carbon quantum dots may comprise at least a portion of a fiber optic cable 120, 120', such as within the at least one optical fiber 128 or as a coating on the at least one optical fiber 128'. The carbon quantum dots may be exposed to the excitation radiation. As described above, responsive to exposure to the excitation radiation, the carbon quantum dots may exhibit a fluorescence property that is, at least partially, dependent upon the pH of the fluid surrounding the carbon quantum dots. The emitted radiation may be transmitted from the carbon quantum dots to the detector 124, where at least one fluorescence property of the carbon quantum dots may be measured. The pH of fluid in which the carbon quantum dots are disposed may be determined based on a fluorescence property of the carbon quantum dots. The carbon quantum dots, either within the wellbore fluid 140 or within the at least one optical fiber 128, 128', may be substantially chemically inert (e.g., may not be subject to photobleaching) and may remain within the fluid or within the at least one optical fiber 128, 128' when exposed to formation conditions.

[00082] FIG. 4 illustrates a simplified cross-sectional view of a configuration that may be used in a method of forming the carbon quantum dots described herein. The method includes providing an electrolyte 304 and electrodes 306 in a container 302 to form an electrochemical cell 300. Electrical current may be applied to the

electrochemical cell 300 to form carbon quantum dots from a carbon source located in the electrolyte 304.

[00083] The container 302 may be any vessel or container suitable for holding the electrolyte 304 before, during, or after the electrochemical process of the disclosure, as described in further detail below. By way of non-limiting example, the container 302 may comprise a glass beaker configured to receive and hold the electrolyte 304 and the electrodes 306.

[00084] The electrodes 306 may include at least one anode and at least one cathode. In some embodiments, each of the electrodes 306 comprises platinum. The electrodes 306 may be coupled to a power supply configured to provide an electrical current to the electrochemical cell 300. A current may be applied to the electrochemical cell 300 for a sufficient period of time to form carbon quantum dots from the electrolyte 304. By way of non-limiting example, the applied current density may be within a range extending from about 100 milliamperes per square centimeter (mA/cm^2) to about 1,100 mA/cm^2 (e.g., from about 100 mA/cm^2 to about 500 mA/cm^2 , from about 500 mA/cm^2 to about 1,000 mA/cm^2 , or from about 1,000 mA/cm^2 to about 1,100 mA/cm^2). In some embodiments, the applied current density is approximately 1,100 mA/cm^2 . A voltage may be applied between the electrodes 306 during the electrochemical reaction process. In some embodiments, a voltage of approximately 10 volts may be applied between the electrodes 306. Accordingly, the carbon quantum dots may be formed without using a carbon-containing electrode, such as a graphite electrode. Even when using an electrode that includes carbon, such as a graphite electrode, the carbon in the resulting carbon quantum dots may not include any significant amount of carbon that originated from the electrode.

[00085] Although FIG. 4 illustrates two electrodes 306, the electrochemical cell 300 may include any number of electrodes 306 (e.g., three, four, five, etc.).

[00086] After a suitable period of time, carbon quantum dots may form in the electrochemical cell 300. The electrolyte 304 may be evaporated and any solids may be collected. The solids may include amorphous carbon quantum dots. Accordingly, carbon quantum dots exhibiting different fluorescence properties (e.g., peak emission wavelengths) may be formed in the electrochemical cell 300.

[00087] The electrolyte 304 may include at least one carbon source formulated for providing carbon for forming the carbon quantum dots during the electrochemical process. The electrolyte 304 may further include a source of ions, such as an acid, a base, or a buffer. In some embodiments, the source of ions includes a hydroxide, such

as, for example, sodium hydroxide (NaOH), potassium hydroxide (KOH), cesium hydroxide (CsOH), magnesium hydroxide ($\text{Mg}(\text{OH})_2$), calcium hydroxide ($\text{Ca}(\text{OH})_2$), and barium hydroxide ($\text{Ba}(\text{OH})_2$). In some embodiments, the at least another material has a concentration of about 1 molar and may be formulated such that the electrolyte 304 has a pH between about 13 and about 14.

[00088] The carbon source may constitute between about 1 volume percent and about 100 volume percent of the electrolyte 304, such as between about 1 volume percent and about 10 volume percent, between about 10 volume percent and about 25 volume percent, between about 25 volume percent and about 50 volume percent, and between about 50 volume percent and about 100 volume percent. The carbon source may be dispersed in water. In some embodiments, a ratio of the carbon source to water is approximately one to two (1:2).

[00089] The carbon source may include any water soluble carbon-containing material. In some embodiments, the carbon source is an alcohol, such as methanol, ethanol, propanol, butanol, combinations thereof, etc. In some embodiments, the carbon source is ethanol. Carbon quantum dots formed from such carbon sources may comprise carbon, hydrogen, and oxygen (e.g., may be undoped).

[00090] The carbon-quantum dots may be formulated to include at least one of nitrogen, boron, silicon, and phosphorus. The electrolyte 304 may be formulated to include at least one of a nitrogen source, a boron source, a silicon source, and a phosphorus source. The nitrogen source, the boron source, the silicon source, and the phosphorus source may also include carbon. Suitable nitrogen-containing carbon sources may include amino alcohols, such as, for example, ethanolamine ($\text{C}_2\text{H}_7\text{NO}$), diethanolamine ($\text{C}_4\text{H}_{11}\text{NO}_2$), and triethanolamine ($\text{C}_6\text{H}_{15}\text{NO}_3$). The nitrogen-containing carbon source may include a 2-aminoalcohol, such as, for example, 2-amino-1-propanol (alaninol) ($\text{C}_3\text{H}_9\text{NO}$), 2-amino-1,3-propanediol (serinol) ($\text{C}_3\text{H}_9\text{NO}_2$), tryptophanol ($\text{C}_{11}\text{H}_{14}\text{N}_2\text{O}$), a 1-amino-2-propanol ($\text{C}_3\text{H}_9\text{NO}$), and a propanolamine, such as metoprolol ($\text{C}_{15}\text{H}_{25}\text{NO}_3$), nadolol ($\text{C}_{17}\text{H}_{27}\text{NO}_4$), and phenylpropanolamine ($\text{C}_9\text{H}_{13}\text{NO}$), or any other water soluble carbon source including nitrogen.

[00091] Suitable boron-containing carbon sources may include water soluble organoboranes, such as, for example, a trialkylborane ($(\text{R}_1\text{R}_2\text{R}_3\text{B})$), wherein R_1 , R_2 , and R_3 are alkyl groups. Suitable trialkylboranes may include, for example, trimethylborane ($(\text{CH}_3)_3\text{B}$), triethylborane ($(\text{C}_2\text{H}_5)_3\text{B}$), and tripropylborane ($(\text{C}_3\text{H}_7)_3\text{B}$). Other boron-containing sources may include diborane (H_6B_2), a carborane, decaborane ($\text{B}_{10}\text{H}_{14}$), a boronic acid, such as, for example, phenylboronic acid ($\text{C}_6\text{H}_7\text{BO}_2$), methylboronic acid

($\text{CH}_3\text{B}(\text{OH})_2$), and propenylboronic acid ($\text{C}_3\text{H}_5\text{B}(\text{OH})_2$). Other boron-containing sources may include a boratobenzene (a borabenzene), such as, for example, 1-boratanaphthalene, 9-borataanthracene, boracyclooctantetraene, and 2,2'-diboratabiphenyl.

[00092] In some embodiments, the electrolyte 304 includes a compound including a nitrogen source and a boron source. For example, the electrolyte 304 may include a borane-amine complex, such as borane trimethylamine ($(\text{CH}_3)_3\text{NBH}_3$) and borane tert-butylamine complex ($(\text{CH}_3)_3\text{CNH}_2\text{BH}_3$).

[00093] Suitable silicon-containing carbon sources may include hydroxyalkylsilanes, (e.g., hydroxymethyltrimethylsilane ($\text{HOCH}_2\text{Si}(\text{CH}_3)_3$), hydroxyethoxysilatrane ($\text{C}_8\text{H}_{17}\text{NO}_5\text{Si}$)), and other water soluble organosilicon compounds.

[00094] Suitable phosphorus-containing compounds may include phosphate esters such as, for example, a phosphatidylcholine, triphenylphosphate ($\text{OP}(\text{OC}_6\text{H}_5)_3$), cyclophosphamide ($\text{C}_7\text{H}_{15}\text{Cl}_2\text{N}_2\text{O}_2\text{P}$), and parathion ($\text{C}_{10}\text{H}_{14}\text{NO}_5\text{PS}$), phosphonic acids and their esters, such as, for example, glyphosate ($\text{C}_3\text{H}_8\text{NO}_5\text{P}$), phosphoranes, such as, for example, pentaphenylphosphorane ($\text{P}(\text{C}_6\text{H}_5)_5$), and organophosphorus compounds, such as, for example, triphenylphosphine ($\text{P}(\text{C}_6\text{H}_5)_3$), phosphites, phosphonites, and phosphinites.

[00095] Accordingly, the carbon quantum dots may be doped with at least one of nitrogen, boron, silicon, and phosphorus. The fluorescence properties of the carbon quantum dots may depend on the composition of the electrolyte 304 (e.g., the carbon source) from which the carbon quantum dots are formed.

[00096] At least one of the nitrogen-containing carbon source, the boron-containing carbon source, the silicon-containing carbon source, and the phosphorus-containing carbon source may constitute between about 0 volume percent and about 100 volume percent of the carbon source, such as between about 1 volume percent and about 10 volume percent, between about 10 volume percent and about 25 volume percent, between about 25 volume percent and about 50 volume percent, or between about 50 volume percent and about 100 volume percent of the carbon source.

[00097] The carbon quantum dots may further include C=C bonds and C-O functional groups. The carbon quantum dots may be undoped, nitrogen-doped, boron-doped, silicon-doped, phosphorus-doped, and combinations thereof. For example, at least some of the carbon quantum dots may include one of nitrogen, boron, silicon, and phosphorus and at least some of the carbon quantum dots may include at least another of nitrogen, boron, silicon, and phosphorus.

[00098] Any of the carbon quantum dots referenced herein may be suitable for the methods disclosed herein, especially those relating to the use of the carbon quantum dots in hydraulic fracturing including multi-zone fracturing, enhanced oil recovery, flooding, etc.

[00099] Typically, the carbon quantum dots referenced herein may be generally spherical in shape having diameters ranging from between about 1 nm to about 10 nm. The carbon quantum dots may be separated into narrower size ranges by suitable methods, which may include dialysis. For example, the carbon quantum dots may be passed through at least one membrane having a pore size corresponding to a desired size of the carbon quantum dots. The separated carbon quantum dots may have a diameter ranging from between about 1 nm and about 3 nm, between about 3 nm and about 5 nm, or between about 5 nm and about 10 nm. Carbon quantum dots having different sizes may exhibit different optical properties.

[000100] The carbon quantum dots may be soluble in aqueous-based solutions. The carbon quantum dots may include exposed hydroxyl groups, exposed carboxyl groups, exposed ether groups and combinations thereof. In some embodiments, exposed surfaces of the carbon quantum dots may be functionalized with at least one of additional hydrophilic functional groups or hydrophobic functional groups. Non-limiting examples of hydrophilic groups include, for example, a hydroxyl group, a carboxyl group, an amine group, a thiol group, an ether group and a phosphate group. Non-limiting examples of hydrophobic groups include, for example, an alkyl group, an alkenyl group, an alkynyl group, and an aryl group.

[000101] In some embodiments, a hydrophilic group or a hydrophobic group may be attached to the carbon quantum dots in a condensation reaction or a hydrolysis reaction, such as described in U.S. Patent Application Serial No. 14/169,432, filed January 31, 2014, and titled "NANO-SURFACTANTS FOR ENHANCED OIL RECOVERY, AND METHODS OF FORMING AND USING SUCH NANO-SURFACTANTS," or a reaction mechanism described in U.S. Patent Application Serial No. 14/519,496, filed October 21, 2014, and titled "SUSPENSIONS FOR ENHANCED HYDROCARBON RECOVERY, AND METHODS OF RECOVERING HYDROCARBONS USING THE SUSPENSIONS," the disclosure of each of which applications is hereby incorporated herein in its entirety by this reference. For example, a hydrophilic precursor or a hydrophobic precursor may include a hydrolyzable group and may be attached to a surface of the carbon quantum dots by hydrolyzing the hydrolyzable group. In other embodiments, a hydrophilic or hydrophobic group may be attached to the carbon

quantum dots by a condensation reaction between the carbon quantum dots and one of a hydrophilic precursor and a hydrophobic precursor.

[000102] The carbon quantum dots may be stable at elevated temperatures (e.g., up to about 400°C) and a wide range of pH (e.g., a pH between about 0 and about 14.0). Emission spectra of the carbon quantum dots may be dependent upon the size and composition of the carbon quantum dots.

[000103] The carbon quantum dots may be formulated to interact with surfaces of the subterranean formation. For example, exposed surfaces of the carbon quantum dots may be functionalized with at least one functional group, such as with at least one hydrophilic group, at least one hydrophobic (e.g., oleophilic) group, and combinations thereof (e.g., to form amphiphilic surfaces). Hydrophilic groups on surfaces of the carbon quantum dots may interact with water wet surfaces of the subterranean formation and hydrophobic groups may interact with oil wet surfaces of the subterranean formation.

[000104] In some embodiments, the hydrophilic carbon quantum dots may be formulated to exhibit a different optical property than the hydrophobic carbon quantum dots. For example, the hydrophilic carbon quantum dots may have a different size than the hydrophobic carbon quantum dots. In other embodiments, the hydrophilic carbon quantum dots are doped with at least one of nitrogen, boron, silicon, phosphorus, etc., and the hydrophobic carbon quantum dots are undoped or doped with at least another of nitrogen, boron, silicon, and phosphorus.

[000105] A mixture of hydrophilic and hydrophobic carbon quantum dots may be introduced into the subterranean formation by pumping the mixture of carbon quantum dots into the well penetrating the formation. A produced fluid may include at least one of the hydrophilic carbon quantum dots and the hydrophobic carbon quantum dots.

[000106] The proportion of hydrophilic carbon quantum dots to hydrophobic carbon quantum dots may be determined by, for example, comparing the fluorescence intensity at the peak emission wavelength of the hydrophilic carbon quantum dots to the fluorescence intensity at the peak emission wavelength of the hydrophobic carbon quantum dots.

[000107] A ratio of formation surfaces that are water wet relative to formation surfaces that are oil wet may correspond to a proportion of hydrophilic carbon quantum dots to hydrophobic carbon quantum dots in the produced fluid.

[000108] Information about the wettability of the formation surfaces may be particularly useful where stimulation methods include expensive fluids, such as those including surfactants, micellar fluids, or polymers. Where the formation includes more water wet surfaces than oil wet surfaces, an aqueous-based stimulation fluid may be used

during further stimulation procedures. Where the formation includes more oil wet surfaces than water wet surfaces, a non-polar stimulation fluid may be used during further stimulation procedures.

[000109] In some embodiments, the carbon quantum dots may be introduced into the subterranean formation during stimulation processes. Stimulation processes such as, for example, hydraulic fracturing (i.e., “fracking”) may be used to enhance hydrocarbon recovery from a hydrocarbon-bearing subterranean formation. In hydraulic fracturing operations, hydraulic fractures may be created or enlarged by injecting a fluid containing additives and including a suspended proppant material (e.g., sand, ceramics, etc.) into a targeted subterranean formation under elevated pressure conditions sufficient to cause the hydrocarbon-bearing formation material to fracture. The carbon quantum dots may be included in the fracturing fluid.

[000110] In addition to determining a chemical or physical parameter of the formation fluid (such as pH), it may be desirable to determine a location (e.g., a zone) from which produced fluids (e.g., hydrocarbons, water, etc.) originate. It is contemplated that carbon quantum dots exhibiting different optical properties may be introduced into various zones of the subterranean formation (as well as on an optical fiber). In some embodiments, between about one and about twenty different types of carbon quantum dots, each exhibiting one or more different optical properties than the other types of carbon quantum dots, may be introduced into one or more different zones of the subterranean formation.

[000111] As another example, carbon quantum dots may be introduced proximate the aquifer zone. Produced fluids may be analyzed to determine if the produced fluids include an optical property of the carbon quantum dots introduced into the aquifer zone. Identification of the corresponding optical property may be an indication that the produced fluid includes water from the aquifer zone.

[000112] In some embodiments, the carbon quantum dots may be used to identify a source of fluids produced from a production well. Carbon quantum dots introduced into each zone of the subterranean formation may exhibit a different optical property than carbon quantum dots introduced into other zones of the subterranean formation. In particular, by way of non-limiting example, the carbon quantum dots may be dispersed in produced fluids to indicate the source of the hydrocarbons. The optical property, such as fluorescence, of the carbon quantum dots in the hydrocarbons may be an indication of the source of the hydrocarbons.

[000113] Thus, in some embodiments, carbon quantum dots exhibiting different optical properties may be introduced into multiple zones of the subterranean formation. (The term “zone” as used herein may refer to separate formations within a well or separate areas within a single formation within the well.) The carbon quantum dots introduced in one zone may be different from the carbon quantum dots introduced into another zone being treated. The carbon quantum dots introduced into different zones are preferably qualitatively (and preferably also quantitatively) distinguishable in order to identify the zone or area within the formation from which a produced fluid originates. As such, the carbon quantum dots introduced into each of the zones being treated preferably exhibit unique absorption and optical properties such that the properties of carbon quantum dots introduced into one zone is unable to mask the properties of carbon quantum dots introduced into another zone.

[000114] For instance, carbon quantum dots having a first chemical composition (e.g., undoped, nitrogen-doped, boron-doped, silicon-doped, phosphorus-doped, and combinations thereof) may be introduced into a first zone and carbon quantum dots having a different composition may be introduced into a second zone. Detection of an optical property in a produced fluid corresponding to an optical property of carbon quantum dots disposed in a zone of the subterranean formation may be an indication that the produced fluid originated from the corresponding zone. Detection of optical properties in the produced fluid that correspond to carbon quantum dots introduced into different zones may be an indication that the produced fluid comprises formation fluid originating from each of the corresponding zones.

[000115] Thus, for instance, a first fluid having fluorescent carbon quantum dots may be introduced into a first zone of a formation. A second fluid having qualitatively distinguishable carbon quantum dots from the fluid introduced into the first zone) may be introduced into a second zone of a formation. A proportion of formation fluid originating from each zone may be determined by, for example, the relative value or intensity of the corresponding measured optical property in the formation fluid. (It is understood that the terms “first” and “second” need not be sequential and only denote the order of addition of the fluids into the formation or the order of addition of zones treated in a formation. In other words, the first zone is merely penultimate to the second zone. Thus, for example, the “first zone” may refer to a third zone of a multi-zone formation and the “second zone” may refer to a sixth zone of a multi-zone

formation; the “first treatment fluid” may be a fourth treatment fluid introduced while the “second treatment fluid” may be the eighth treatment fluid introduced.)

[000116] As one non-limiting example, referring to FIG. 1, a first group of carbon quantum dots exhibiting a first optical property may be introduced into at least one of the first zone 101, the aquifer zone 102, the second zone 103, the third zone 104, the fourth zone 105, the fifth zone 106, and the sixth zone 107 and at least a second group of carbon quantum dots exhibiting a second optical property may be introduced into another of the first zone 101, the aquifer zone 102, the second zone 103, the third zone 104, the fourth zone 105, the fifth zone 106, and the sixth zone 107. An absorption spectrum, an emission spectrum or other optical property of produced fluids may be measured to determine if any of the first group of carbon quantum dots or the second group of carbon quantum dots are present in the produced fluid. For example, an emission spectrum of the produced fluid may be used to determine a proportion of the produced fluid that originated from each zone based on the fluorescence intensity of the carbon quantum dots introduced into each zone. By way of non-limiting example, carbon quantum dots introduced into a first zone with a first fracturing fluid may be formulated to fluoresce at wavelengths that correspond to blue light (e.g., at wavelengths of about 450 nm) and carbon quantum dots introduced into a second zone with a second fracturing fluid may be formulated to fluoresce at wavelengths that correspond to red light (e.g., at wavelengths of about 700 nm). An emission spectrum (e.g., a fluorescence color) of produced fluid may indicate whether the produced fluid originated from the first zone or the second zone.

[000117] Referring to the carbon quantum dots here, in some embodiments, the first group of carbon quantum dots may include undoped carbon quantum dots and the at least a second group of carbon quantum dots may be doped with one or more of nitrogen, boron, silicon, and phosphorus. In other embodiments, the first group of carbon quantum dots may be undoped or may be doped with nitrogen, boron, silicon, or phosphorus and the at least a second group of carbon quantum dots may be another of undoped or doped with nitrogen, boron, silicon, or phosphorus.

[000118] In addition to monitoring different zones in hydrocarbon production wells and determining the zone in which hydrocarbons have been produced from the formation, the carbon quantum dots may also be used to monitor oil and gas for flow assurance and for maintaining regulatory compliance. The ability to analyze the fluids on-site, quickly and frequently, further assists operators to detect flow assurance, asset integrity and process problems early enabling them to take

preventative action to minimize the risks of production loss and to adapt the treatment operation.

[000119] Further, the carbon quantum dots may also be used to determine sites of flowback water and produced water as well as for detection or early warning of phenomena such as water breakthrough.

[000120] In addition to their use in hydraulic fracturing, the carbon quantum dots may be included in fluids used in well treating applications near wellbore and may be directed toward improving wellbore productivity and/or controlling the production of formation sand. Particular examples include gravel packing and “frac-packs.” Typical gravel packing and frac packing methods.

[000121] In gravel packing, sand is used to pre-pack a screen to prevent the passage of formation particles or unconsolidated materials from the formation into the wellbore during production of fluids from the formation. Gravel packing is essentially a technique for building a two-stage filter downhole. The filter consists of gravel pack sand and a screen or liner. The gravel pack sand is sized according to the particle size distribution of the unconsolidated materials. The screen or liner has openings that are sized to retain the gravel pack sand. Thus the gravel pack particulates retain the unconsolidated formation materials and the screen or liner retains the gravel pack particulates. The gravel pack particulates and the screen or liner act together to reduce or eliminate the production of the unconsolidated formation materials with the oil or gas production. A slurry of sand introduced into the well further may contain the carbon quantum dots. The slurry is then pumped into the workstring within the well until the slurry is within about 150 to about 300 feet of the primary port. Positioning of a crossover service tool allows the slurry to travel into the screen/casing annulus. Particulates are retained by the screen or liner and the remaining fluid leaks off into the formation allowing a tightly packed sand filter to remain in place. Monitoring the carbon quantum dots provides information of the type and amount of the produced fluid from the formation.

[000122] The carbon quantum dots may further be used in a frac pack operation where the unconsolidated formation is hydraulically fractured while a two-stage filter of gravel pack is simultaneously built. In frac packing, the processes of hydraulic fracturing and gravel packing are combined into a single treatment to provide stimulated production and an annular gravel pack to reduce formation sand production.

[000123] Further, carbon quantum dots may be used in combination with an acid in an acid fracturing operation. Carbon quantum dots are stable in very low pH also. CQDs can be mixed with acids for acid fracturing operations. The acid is a corrosive, very low pH acid which reacts with the surrounding formation. The method is particularly effective with sandstone and carbonate formations. Acids such as hydrochloric acid, formic acid, and acetic acid are injected at high rates and pressures into the formation with the fluid to intentionally cause the formation to fail by inducing a fracture in the subterranean rock. In another embodiment, the fluid of the invention may contain the acid. Fractures, originating adjacent to the wellbore, initiate as two wings growing away from the wellbore in opposite directions. The acid is used to dissolve or etch channels or grooves along the fracture face so that after pressure is relieved and the fracture heals, there continues to exist non-uniform highly conductive channels, allowing unrestrained hydrocarbon flow from the reservoir to the wellbore. In contrast, with propped fracturing, fracture conductivity is maintained by propping open the created fracture with a solid material, such as sand, bauxite, ceramic, and certain lighter weight materials. Conductivity in acid fracturing is obtained by etching of the fracture faces with an etching acid instead of by using proppants to prevent the fracture from closing. Monitoring of the carbon quantum dots provides information of the type and amount of the produced fluid from the formation and the success of the acid fracturing operation.

[000124] Carbon quantum dots may further be used, in addition to acid fracturing, in matrix acidizing. In matrix acidizing, a fluid containing an organic or inorganic acid or acid-forming material is injected into the formation below fracture pressure such that the acid or acid-forming material reacts with minerals in the formation. A channel or wormholes is created within the formation. As subsequent fluid is pumped into the formation, it tends to flow along the channel, leaving the rest of the formation untreated. Matrix acidizing is often used to enhance near-wellbore permeability. In addition to enhancing the production of hydrocarbons, blockages caused by natural or man-made conditions may further be removed during matrix acidizing. For instance, formation damage caused by drilling mud invasion and clay migration may also be removed during the process. The use of matrix acidizing is often preferred in the treatment of carbonate formations since the reaction products are soluble in the spent acid. Monitoring of the carbon quantum dots during matrix acidizing informs the

operator of the amount of fluids being produced during the operation and further provides a measurement on the value of the matrix acidizing operation.

[000125] In yet other embodiments, the carbon quantum dots may be used as a tracer to determine fluid flow paths through the subterranean formation and into produced fluids. For instance, the carbon quantum dots may be introduced into an injection fluids during at least one of water flooding, steam assisted gravity drainage, steam flooding, cyclic steam stimulation, or other enhanced oil recovery stimulation processes.

[000126] In other embodiments, different carbon quantum dots are preferably introduced into the aqueous fluid introduced into the different injection wells. Fluids produced from one or more production wells may be analyzed for the presence of the carbon quantum dots in the produced fluid. The presence of carbon quantum dots in produced fluids from a production well may indicate water breakthrough. Thus, not only can water breakthrough in the production well be determined but the injection well from which the water has flowed in into the production well can be identified. The injection well, into which the water in the breakthrough water has been determined to have been initially introduced, can be shut off. Thus, the carbon quantum dots can be used to optimize enhancement of hydrocarbons during secondary recovery operations by shutting down the injection well and thus terminating the flow of water from the injection well directly into the production well.

[000127] The carbon quantum dots used in this embodiment are typically water soluble. Carbon quantum dots are introduced into the aqueous fluid which is then introduced into the injection well. The aqueous fluid introduced into each of the injection wells contains qualitatively distinguishable carbon quantum dots. The aqueous fluid serves to maintain pressure in the hydrocarbon-bearing reservoir. The pressure is maintained above the bubble point. Should carbon quantum dots be detected in produced fluid from the production well, the operator would know to take remedial action and shut down the injection well from which the carbon quantum dots had originally been introduced. The injection well, once shut down, may be repaired to prevent further flow of aqueous fluid into the production well.

EXAMPLES

[000128] The methods that may be described above or claimed herein and any other methods which may fall within the scope of the appended claims can be performed in any desired suitable order and are not necessarily limited to any sequence described herein or as may be listed in the appended claims. Further, the methods of the present disclosure do not necessarily require use of the particular embodiments shown and described herein, but are equally applicable with any other suitable structure, form and configuration of components.

[000129] While exemplary embodiments of the disclosure have been shown and described, many variations, modifications and/or changes of the system, apparatus and methods of the present disclosure, such as in the components, details of construction and operation, arrangement of parts and/or methods of use, are possible, contemplated by the patent applicant(s), within the scope of the appended claims, and may be made and used by one of ordinary skill in the art without departing from the spirit or teachings of the disclosure and scope of appended claims. Thus, all matter herein set forth or shown in the accompanying drawings should be interpreted as illustrative, and the scope of the disclosure and the appended claims should not be limited to the embodiments described and shown herein.

[000130] Embodiment 1: A system for determining at least one property of at least one fluid in at least one subterranean formation, the system comprising: a fluid delivery system configured and positioned to deliver a fluid into at least one of at least one subterranean formation and a wellbore extending through the at least one subterranean formation; a radiation source within the wellbore, the radiation source configured to generate excitation radiation; carbon quantum dots disposed in the fluid; and a detector within the wellbore, the detector configured to measure at least one fluorescence property of the carbon quantum dots.

[000131] Embodiment 2: The system of Embodiment 1, wherein the carbon quantum dots comprise undoped carbon quantum dots.

[000132] Embodiment 3: The system of Embodiment 1, wherein the carbon quantum dots are doped with one or more of nitrogen, boron, silicon, and phosphorus.

[000133] Embodiment 4: The system of any one of Embodiments 1 through 3, wherein the carbon quantum dots comprise a first group of carbon quantum dots and at least a

second group of carbon quantum dots, the first group of carbon quantum dots formulated to exhibit a different fluorescence property than the at least a second group of carbon quantum dots.

[000134] Embodiment 5: The system of Embodiment 4, wherein the first group of carbon quantum dots is dispersed in a first zone of the subterranean formation and the at least a second group of carbon dots is disposed in at least a second zone of the subterranean formation.

[000135] Embodiment 6: The system of any one of Embodiments 1 through 5, wherein the radiation source comprises a laser configured to generate excitation radiation of a substantially monochromatic wavelength or a broadband radiation source comprising one of a collimated LED, an uncollimated LED, or a white light.

[000136] Embodiment 7: The system of any one of Embodiments 1 through 6, wherein the carbon quantum dots include one or more of hydrophilic exposed surfaces and oleophilic exposed surfaces.

[000137] Embodiment 8: A system for determining at least one property of at least one subterranean formation, the system comprising: at least one fiber optic cable within a wellbore extending through at least one subterranean formation, the at least one fiber optic cable including at least one optical fiber comprising carbon quantum dots; a radiation source coupled to the at least one optical fiber, the radiation source configured to generate excitation radiation for transmission through the at least one optical fiber; and a detector coupled to the at least one fiber optic cable, the detector configured to measure at least one fluorescence property of the carbon quantum dots.

[000138] Embodiment 9: The system of Embodiment 8, wherein the carbon quantum dots are disposed within the at least one optical fiber.

[000139] Embodiment 10: The system of Embodiment 8, wherein the at least one optical fiber comprises a coating of the carbon quantum dots on at least a portion thereof.

[000140] Embodiment 11: The system of Embodiment 10, wherein the coating comprises a monolayer of the carbon quantum dots.

[000141] Embodiment 12: The system of any one of Embodiments 8 through 11, wherein the carbon quantum dots comprise a first group of undoped carbon quantum dots and at least a second group of carbon quantum dots doped with one or more of nitrogen, boron, silicon, and phosphorus.

[000142] Embodiment 13: The system of any one of Embodiments 8 through 12, further comprising at least another optical fiber coupled to the detector and configured to transmit emitted radiation from the carbon quantum dots to the detector.

[000143] Embodiment 14: The system of any one of Embodiments 8 through 11, or 13, wherein the carbon quantum dots comprise one or more of nitrogen, boron, silicon, and phosphorus.

[000144] Embodiment 15: The system of any one of Embodiments 8 through 14, wherein the detector is configured to measure at least one of an absorption spectrum, an emission spectrum, and a fluorescence intensity of the carbon quantum dots.

[000145] Embodiment 16: A method of forming carbon quantum dots, the method comprising: providing an electrolyte comprising a carbon source and a source of ions to an electrochemical cell; introducing the electrolyte between platinum electrodes of the electrochemical cell; and applying electrical current between the platinum electrodes to form carbon quantum dots including carbon from the carbon source.

[000146] Embodiment 17: The method of Embodiment 16, wherein providing an electrolyte comprising a carbon source comprises forming an electrolyte comprising one or more of ethanol and ethanolamine.

[000147] Embodiment 18: The method of Embodiment 16 or Embodiment 17, further comprising forming the electrolyte from one or more of a nitrogen source, a boron source, a silicon source, and a phosphorus source.

[000148] Embodiment 19: The method of any one of Embodiments 16 through 18, further comprising forming at least some carbon quantum dots comprising one of nitrogen, boron, silicon, and phosphorus and at least some carbon quantum dots comprising at least another of nitrogen, boron, silicon, and phosphorus.

[000149] Embodiment 20: The method of any one of Embodiment 16 through 19, further comprising forming hydrophilic surfaces on the carbon quantum dots or forming oleophilic surfaces on the carbon quantum dots.

[000150] Embodiment 21: A method of determining at least one property within at least one subterranean formation, the method comprising: introducing at least one fiber optic cable into at least one of at least one subterranean formation and a wellbore extending into the at least one subterranean formation; transmitting excitation radiation through the at least one fiber optic cable from a radiation source coupled to the at least one fiber optic cable; exposing carbon quantum dots disposed in a fluid in the wellbore or on the at least one fiber optic cable to the excitation radiation; receiving, at an optical sensor coupled to the at least one fiber optic cable, an emitted radiation from the carbon quantum dots responsive to exposure of the carbon quantum dots to the excitation radiation; and measuring at least one of an emission spectrum and a fluorescence intensity of the emitted radiation at a detector coupled to the at least one fiber optic cable.

[000151] Embodiment 22: The method of Embodiment 21, wherein measuring at least one of an emission spectrum and a fluorescence intensity of the emitted radiation at a detector comprises measuring the at least one of an emission spectrum and the fluorescence intensity after a time delay.

[000152] Embodiment 23: The method of Embodiment 21 or Embodiment 22, wherein introducing at least one fiber optic cable into at least one of at least one subterranean formation and a wellbore comprises introducing at least one fiber optic cable comprising at least one surface coated with carbon quantum dots into at least one of the at least one subterranean formation and the wellbore.

[000153] Embodiment 24: The method of any one of Embodiment 21 through 23, further comprising disposing a fluid comprising carbon quantum dots doped with one or more of nitrogen, boron, and phosphorus into at least one of the at least one subterranean formation and the wellbore.

[000154] Embodiment 25: The method of any one of Embodiment 21 through 23, further comprising introducing carbon quantum dots exhibiting a first optical property into a first zone of the at least one subterranean formation and introducing carbon quantum dots having a second optical property into a second zone of the at least one subterranean formation.

[000155] Embodiment 26: A method of enhancing the productivity of hydrocarbon containing fluids from a subterranean formation penetrated by a well comprising (a) pumping into the well a fluid comprising a tracer which is either hydrocarbon soluble, water soluble or both hydrocarbon soluble and water soluble and further wherein the tracer comprises carbon quantum dots; and (b) identifying the tracer in fluids produced from the well.

[000156] Embodiment 27: The method of Embodiment 26, wherein the carbon quantum dots are undoped.

[000157] Embodiment 28: The method of Embodiment 26 or 27, wherein at least a portion of the surface of the carbon quantum dots contain carboxyl groups, hydroxyl groups and/or ether groups.

[000158] Embodiment 29: The method of Embodiment 26, wherein the carbon quantum dots are doped with one or more of nitrogen, boron, silicon, and phosphorus.

[000159] Embodiment 30: The method of Embodiment 26, wherein at least a portion of the surface of the carbon quantum dots are hydrophilic and/or oleophilic.

[000160] Embodiment 31: The method of any of Embodiments 26 to 30, wherein the fluid is pumped into the well at a pressure sufficient to enlarge or create a fracture in the formation and further wherein a fracture is created or enlarged in the subterranean formation.

[000161] Embodiment 32: The method of any of Embodiments 26 to 31, wherein the carbon quantum dots comprise a first group of carbon quantum dots and at least a second group of carbon quantum dots, the first group of carbon quantum dots formulated to exhibit a different detection property than the at least a second group of carbon quantum dots.

[000162] Embodiment 33: The method of Embodiment 32, wherein at least one group of carbon quantum dots is soluble in water and at least one other group of carbon quantum dots is soluble in hydrocarbon.

[000163] Embodiment 34: The method of Embodiment 32, wherein the first group of carbon quantum dots is dispersed in a first zone of the subterranean formation and the at least a second group of carbon dots is disposed in at least a second zone of the subterranean formation.

[000164] Embodiment 35: The method of any of Embodiments 26 to 32, wherein the fluid is pumped into the well during a sand control operation.

[000165] Embodiment 36: The method of Embodiment 35, wherein the formation is an unconsolidated formation and further wherein the sand control operation is simultaneously conducted while the unconsolidated formation is hydraulically fractured.

[000166] Embodiment 37: A method of fracturing multiple productive zones of a subterranean formation penetrated by a well, the method comprising: (a) pumping fracturing fluid into the multiple productive zones at a pressure sufficient to enlarge or create fractures in the multiple productive zones, wherein the fracturing fluid pumped into the multiple productive zones comprises fluorescent carbon quantum dots which are either hydrocarbon soluble, water soluble or both hydrocarbon soluble and water soluble and further wherein the fracturing fluid pumped into each of the multiple productive zones contains different fluorescent carbon quantum dots; (b) recovering fluid containing hydrocarbons from one or more of the multiple productive zones; (c) detecting the fluorescent carbon quantum dots in the recovered fluid; and (d)

identifying the zone from which the recovered fluid was produced from the fluorescent carbon quantum dots.

[000167] Embodiment 38: The method of Embodiment 37, further comprising quantitatively determining the amount of hydrocarbons produced from the identified zone from the fluorescent carbon quantum dots.

[000168] Embodiment 39: The method of Embodiment 38, wherein the fluorescent carbon quantum dots include one or more of hydrophilic exposed surfaces and/or oleophilic exposed surfaces.

[000169] Embodiment 40: The method of Embodiment 39, wherein at least a portion of the surface of the fluorescent carbon quantum dots contains carboxyl groups, hydroxyl groups and/or ether groups.

[000170] Embodiment 41: The method of Embodiment 37, wherein the at least a portion of the carbon quantum dots are doped with one or more of nitrogen, boron, silicon, and phosphorus.

[000171] Embodiment 42: A method of fracturing multiple zones of a subterranean formation penetrated by a well which comprises: (a) pumping into each zone of the formation to be fractured a fracturing fluid, wherein the fracturing fluid pumped into each zone comprises a qualitatively distinguishable tracer comprising carbon quantum dots which are either hydrocarbon soluble, water soluble or both hydrocarbon soluble and water soluble; (b) enlarging or creating a fracture in the formation; (c) recovering fluid from at least one of the multiple zones; and (d) identifying the zone within the subterranean formation from which the recovered fluid was produced by identifying the carbon quantum dots in the recovered fluid.

[000172] Embodiment 43: The method of Embodiment 42, further comprising determining the amount of the recovered fluid from the identified zone of step (d).

[000173] Embodiment 44: The method of Embodiment 42, wherein at least a portion of the surface of the carbon quantum dots are hydrophilic and/or oleophilic.

[000174] Embodiment 45: The method of Embodiment 44, wherein at least a portion of the surface of the carbon quantum dots contain carboxyl groups, hydroxyl groups and/or ether groups.

[000175] Embodiment 46: The method of Embodiment 42, wherein the carbon quantum dots are doped with one or more of nitrogen, boron, silicon, and phosphorus.

[000176] Embodiment 47: A method of monitoring the production of fluids produced in multiple productive zones of a subterranean formation penetrated by a well, the method comprising: (a) pumping fracturing fluid into the multiple productive zones at a pressure sufficient to enlarge or create fractures in each of the multiple productive zones, wherein the fracturing fluid comprises fluorescent carbon quantum dots which are either hydrocarbon soluble, water soluble or both hydrocarbon soluble and water soluble and further wherein the fluorescent carbon quantum dots pumped into each of the multiple productive zones is qualitatively and/or quantitatively distinguishable; and (b) monitoring the amount of fluids produced from at least one of the multiple productive zones from the carbon quantum dots in the produced fluid.

[000177] Embodiment 48: The method of Embodiment 47, wherein the monitoring is in real time.

[000178] Embodiment 49: The method of either Embodiments 47 or 48, wherein the monitoring is conducted on the fly.

[000179] Embodiment 50: The method of any of Embodiments 47 to 49, further comprising determining the presence of dispersed oil in produced water from the carbon quantum dots.

[000180] Embodiment 51: The method of Embodiment 47, wherein at least a portion of the surface of the carbon quantum dots are hydrophilic and/or oleophilic.

[000181] Embodiment 52: The method of Embodiment 51, wherein at least a portion of the surface of the carbon quantum dots contains carboxyl groups, hydroxyl groups and/or ether groups.

[000182] Embodiment 53: The method of Embodiment 51, wherein the carbon quantum dots are doped with one or more of nitrogen, boron, silicon, and phosphorus.

[000183] Embodiment 54: A method for enhancing the production of hydrocarbons from a production well penetrating a hydrocarbon-bearing formation, wherein one or more injector wells are associated with the production well, the method comprising: (a) introducing into one or more of the injector wells an aqueous fluid comprising fluorescent carbon quantum dots; (b) flowing at least a portion of the aqueous fluid comprising the fluorescent carbon quantum dots from the one or more injector wells into the production well; and (c) recovering hydrocarbons from the production well.

[000184] Embodiment 55: The method of Embodiment 54, wherein at least a portion of the surface of the carbon quantum dots are hydrophilic and/or oleophilic.

[000185] Embodiment 56: A method for determining water breakthrough in a production well associated with one or more injector wells, the method comprising: (a) injecting an aqueous fluid comprising fluorescent carbon quantum dots as tracer into an injector well; (b) flowing the aqueous fluid from the injector well into the production well; (c) producing fluid from the production well; (d) determining water breakthrough in the production well by qualitatively determining the presence or quantitatively measuring the amount of the fluorescent carbon quantum dots in the produced fluid.

[000186] Embodiment 57: The method of Embodiment 56, wherein at least a portion of the surface of the carbon quantum dots are hydrophilic and/or oleophilic.

[000187] Embodiment 58: A method of increasing hydrocarbon production from a production well penetrating a hydrocarbon-bearing reservoir, wherein more than one injection well is associated with the production well, the method comprising: (a) injecting an aqueous fluid having a water soluble tracer comprising carbon quantum dots into the more than one injection well and maintaining pressure in the hydrocarbon-bearing reservoir above the bubble point of the hydrocarbons in the reservoir, wherein the aqueous fluid pumped into each of the injection wells contains qualitatively distinguishable carbon quantum dots; (b) identifying from hydrocarbons recovered from the production well, upon water breakthrough in the production well, the injection well into which the breakthrough water was injected by qualitatively determining the presence of the carbon quantum dots in the recovered hydrocarbons; and (c) shutting off the injector well identified in step (b).

[000188] Although the foregoing description contains many specifics, these are not to be construed as limiting the scope of the disclosure, but merely as providing certain embodiments. Similarly, other embodiments may be devised that do not depart from the scope of the disclosure. For example, features described herein with reference to one embodiment also may be provided in others of the embodiments described herein. The scope of the disclosure is, therefore, indicated and limited only by the appended claims and their legal equivalents, rather than by the foregoing description. All additions, deletions, and modifications to embodiments of the disclosure, as described and illustrated herein, which fall within the meaning and scope of the claims, are encompassed by the disclosure.

CLAIMS

What is claimed is:

1. A method of enhancing the productivity of hydrocarbon containing fluids from a subterranean formation penetrated by a well comprising:

(a) pumping into the well a fluid comprising a tracer which is either hydrocarbon soluble, water soluble or both hydrocarbon soluble and water soluble and further wherein the tracer comprises carbon quantum dots; and

(b) identifying the tracer in fluids produced from the well.

2. The method of claim 1, wherein the carbon quantum dots are undoped.

3. The method of claim 1, wherein at least a portion of the surface of the carbon quantum dots contain carboxyl groups, hydroxyl groups and/or ether groups.

4. The method of claim 1, wherein the carbon quantum dots are doped with one or more of nitrogen, boron, silicon, and phosphorus.

5. The method of claim 1, wherein at least a portion of the surface of the carbon quantum dots are hydrophilic and/or oleophilic.

6. The method of claim 1, wherein the fluid is pumped into the well during a sand control operation.

7. The method of claim 6, wherein the formation is an unconsolidated formation and further wherein the sand control operation is simultaneously conducted while the unconsolidated formation is hydraulically fractured

8. A method of fracturing multiple zones of a subterranean formation penetrated by a well which comprises:

(a) pumping into each zone of the formation to be fractured a fracturing fluid, wherein the fracturing fluid pumped into each zone comprises a qualitatively distinguishable tracer comprising carbon quantum dots which are either hydrocarbon soluble, water soluble or both hydrocarbon soluble and water soluble;

(b) enlarging or creating a fracture in the formation;

(c) recovering fluid from at least one of the multiple zones; and

(d) identifying the zone within the subterranean formation from which the recovered fluid was produced by identifying the carbon quantum dots in the recovered fluid.

9. The method of claim 8, further comprising determining the amount of the recovered fluid from the identified zone of step (d).

10. The method of claim 8, wherein the carbon quantum dots comprise a first group of carbon quantum dots and at least a second group of carbon quantum dots, the first group of carbon quantum dots formulated to exhibit a different detection property than the at least a second group of carbon quantum dots.

11. The method of claim 10, wherein at least one group of carbon quantum dots is soluble in water and at least one other group of carbon quantum dots is soluble in hydrocarbon.

12. The method of claim 8, further comprising quantitatively determining the amount of hydrocarbons produced from the identified zone from the fluorescent carbon quantum dots.

13. The method of claim 8, wherein the fluorescent carbon quantum dots include one or more of hydrophilic exposed surfaces and/or oleophilic exposed surfaces.

14. The method of claim 8, wherein the carbon quantum dots are doped with one or more of nitrogen, boron, silicon, and phosphorus.

15. A method of monitoring the production of fluids produced in multiple productive zones of a subterranean formation penetrated by a well, the method comprising:

(a) pumping fracturing fluid into the multiple productive zones at a pressure sufficient to enlarge or create fractures in each of the multiple productive zones, wherein the fracturing fluid comprises fluorescent carbon quantum dots which are either hydrocarbon soluble, water soluble or both hydrocarbon soluble and water soluble and further wherein the fluorescent carbon quantum dots pumped into each of the multiple productive zones is qualitatively and/or quantitatively distinguishable; and

(b) monitoring the amount of fluids produced from at least one of the multiple productive zones from the carbon quantum dots in the produced fluid.

16. The method of claim 15, wherein the monitoring is in real time.
17. The method of claim 15, wherein the monitoring is conducted on the fly.
18. The method of claim 15, further comprising determining the presence of dispersed oil in produced water from the carbon quantum dots.
19. The method of claim 15, wherein at least a portion of the surface of the carbon quantum dots are hydrophilic and/or oleophilic.
20. The method of claim 19, wherein at least a portion of the surface of the carbon quantum dots contains carboxyl groups, hydroxyl groups and/or ether groups.
21. The method of claim 19, wherein the carbon quantum dots are doped with one or more of nitrogen, boron, silicon, and phosphorus.
22. A method for determining water breakthrough in a production well associated with one or more injector wells, the method comprising:
 - (a) injecting an aqueous fluid comprising fluorescent carbon quantum dots as tracer into an injector well;
 - (b) flowing the aqueous fluid from the injector well into the production well;
 - (c) producing fluid from the production well;
 - (d) determining water breakthrough in the production well by qualitatively determining the presence or quantitatively measuring the amount of the fluorescent carbon quantum dots in the produced fluid.
23. The method of claim 22, wherein at least a portion of the surface of the carbon quantum dots are hydrophilic and/or oleophilic.
24. A method of increasing hydrocarbon production from a production well penetrating a hydrocarbon-bearing reservoir, wherein more than one injection well is associated with the production well, the method comprising:
 - (a) injecting an aqueous fluid having a water soluble tracer comprising carbon quantum dots into the more than one injection well and maintaining pressure in the hydrocarbon-bearing reservoir above the bubble point of the hydrocarbons in the reservoir, wherein the aqueous fluid pumped into each of the injection wells contains qualitatively distinguishable carbon quantum dots;
 - (b) identifying from hydrocarbons recovered from the production well, upon water breakthrough in the production well, the injection well into which the breakthrough

water was injected by qualitatively determining the presence of the carbon quantum dots in the recovered hydrocarbons; and

- (c) shutting off the injector well identified in step (b).

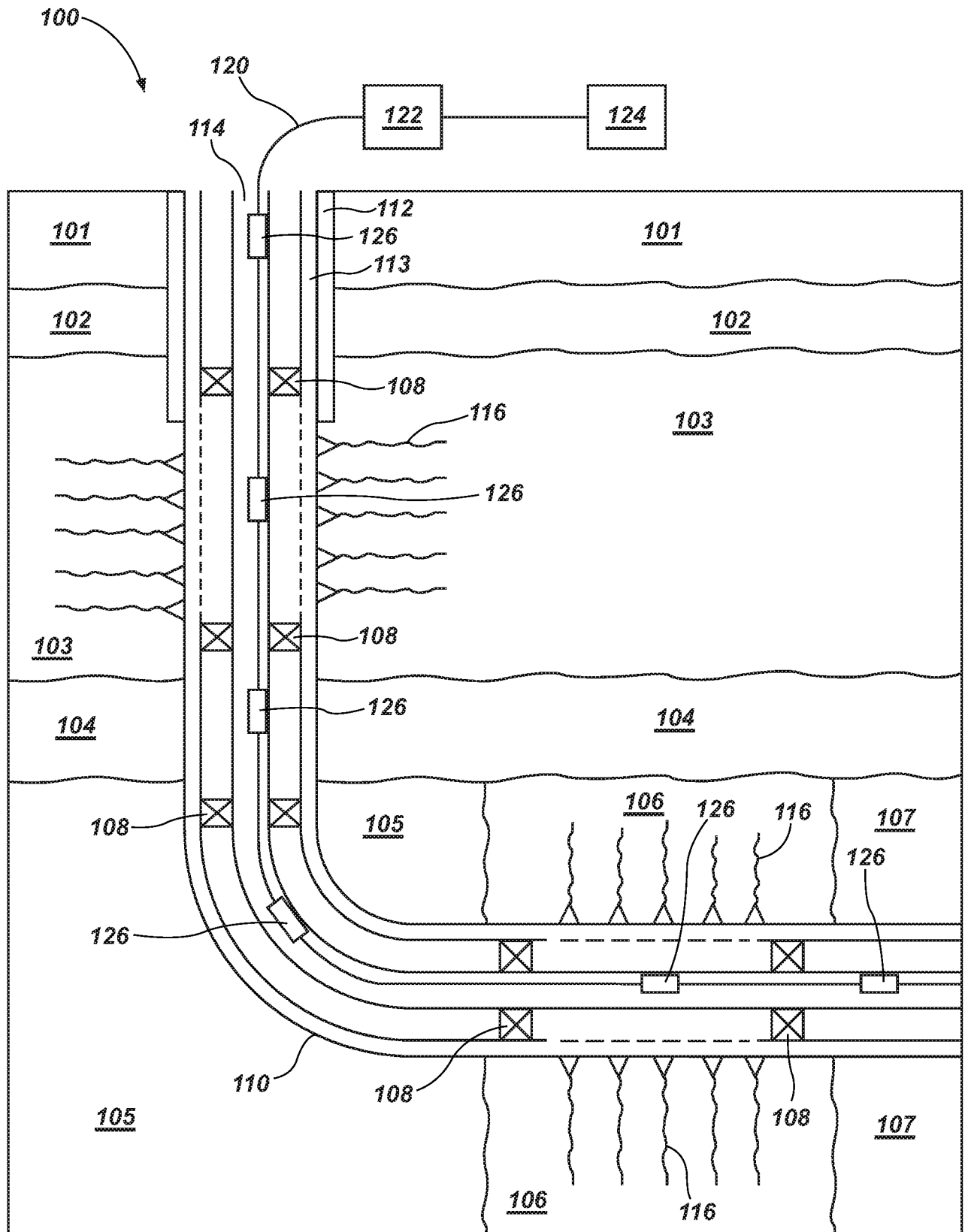

FIG. 1

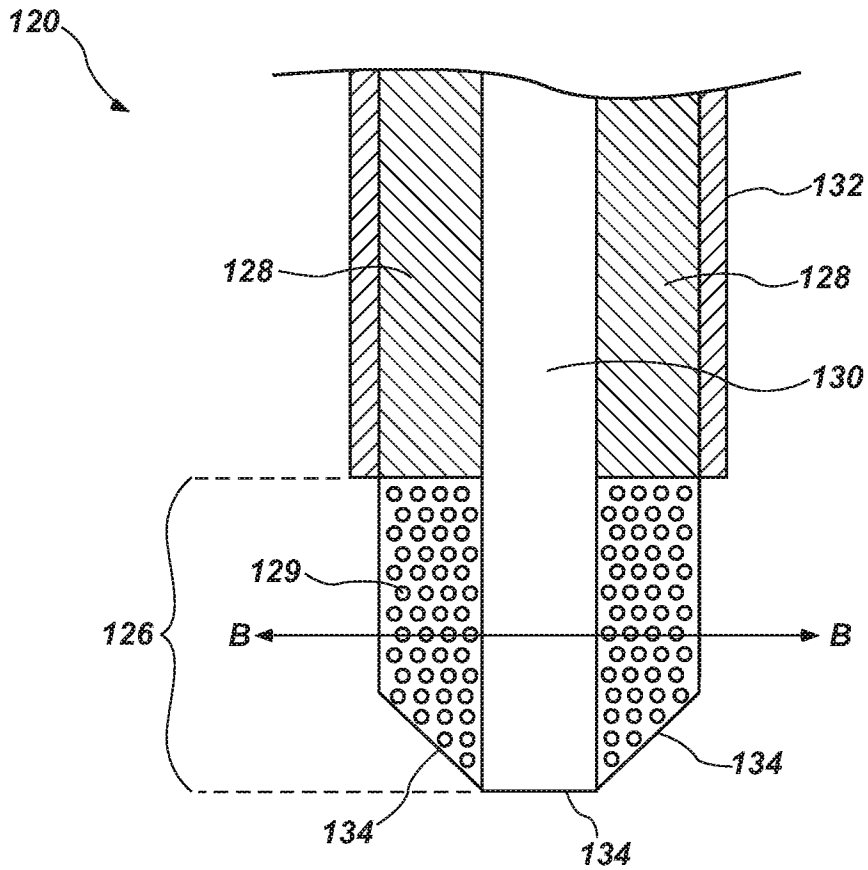

FIG. 2A

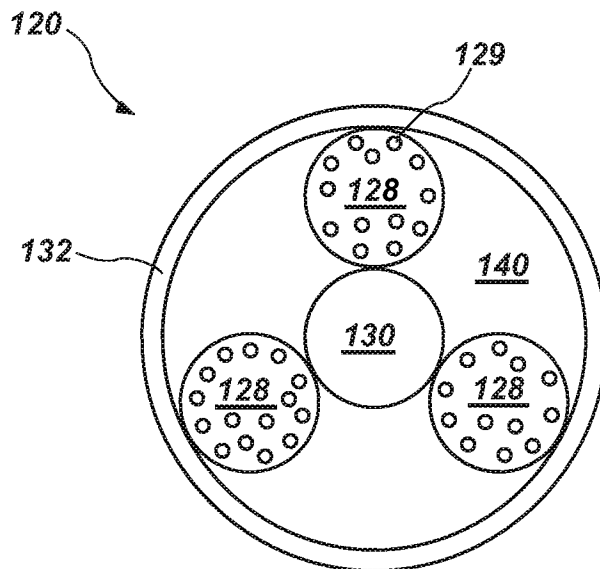

FIG. 2B

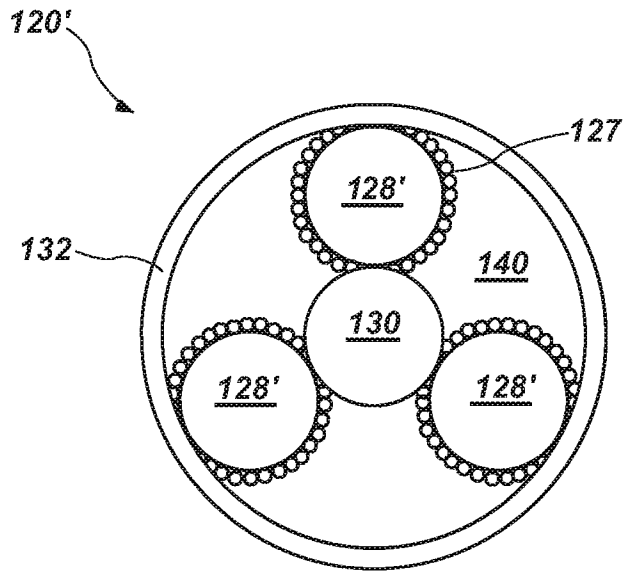

FIG. 2C

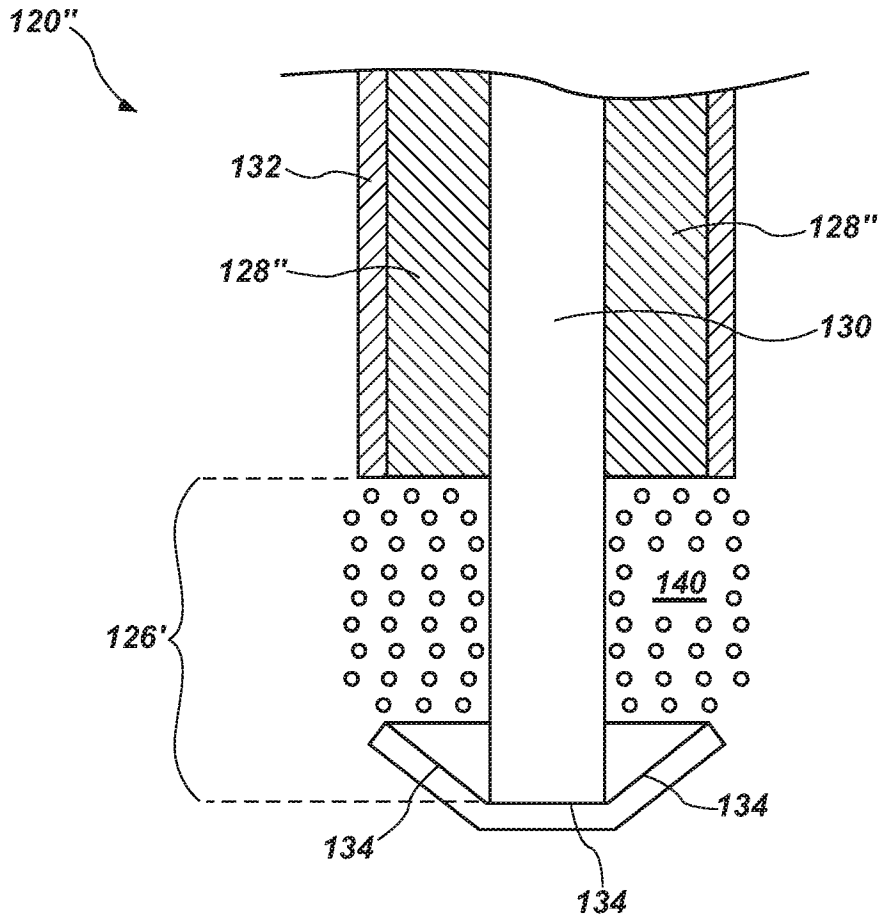

FIG. 2D

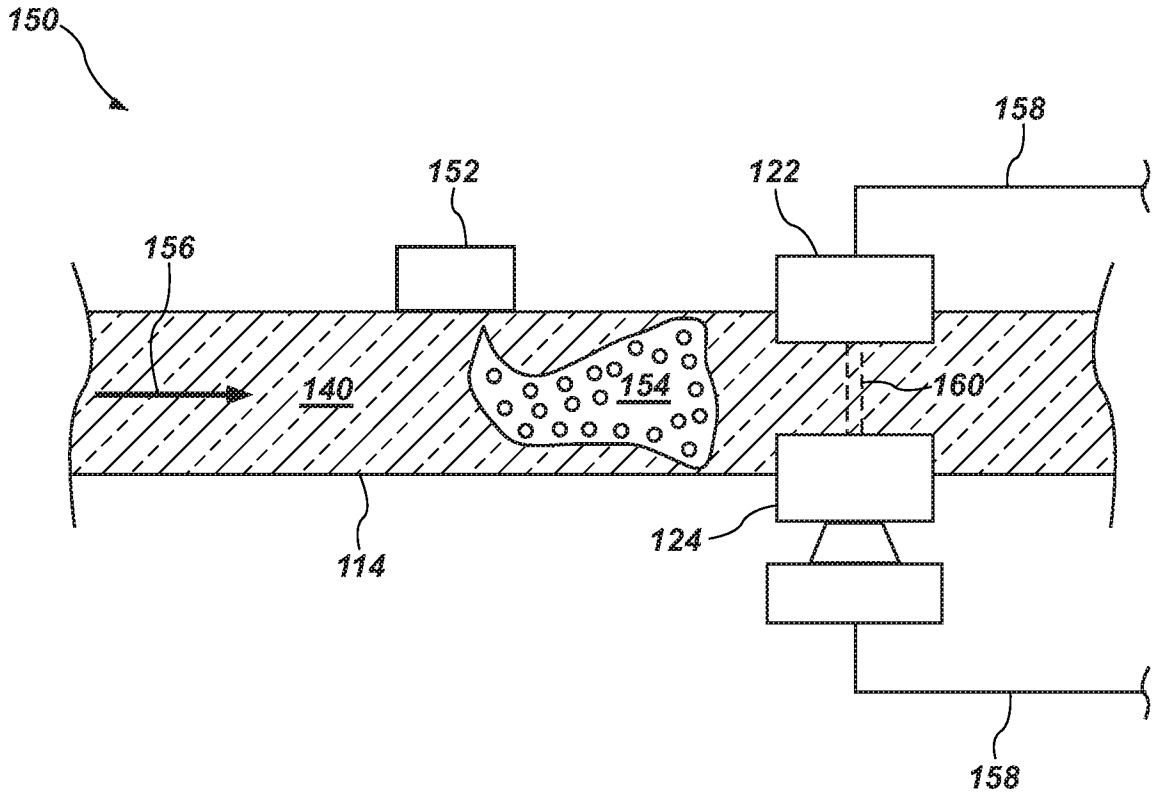

FIG. 2E

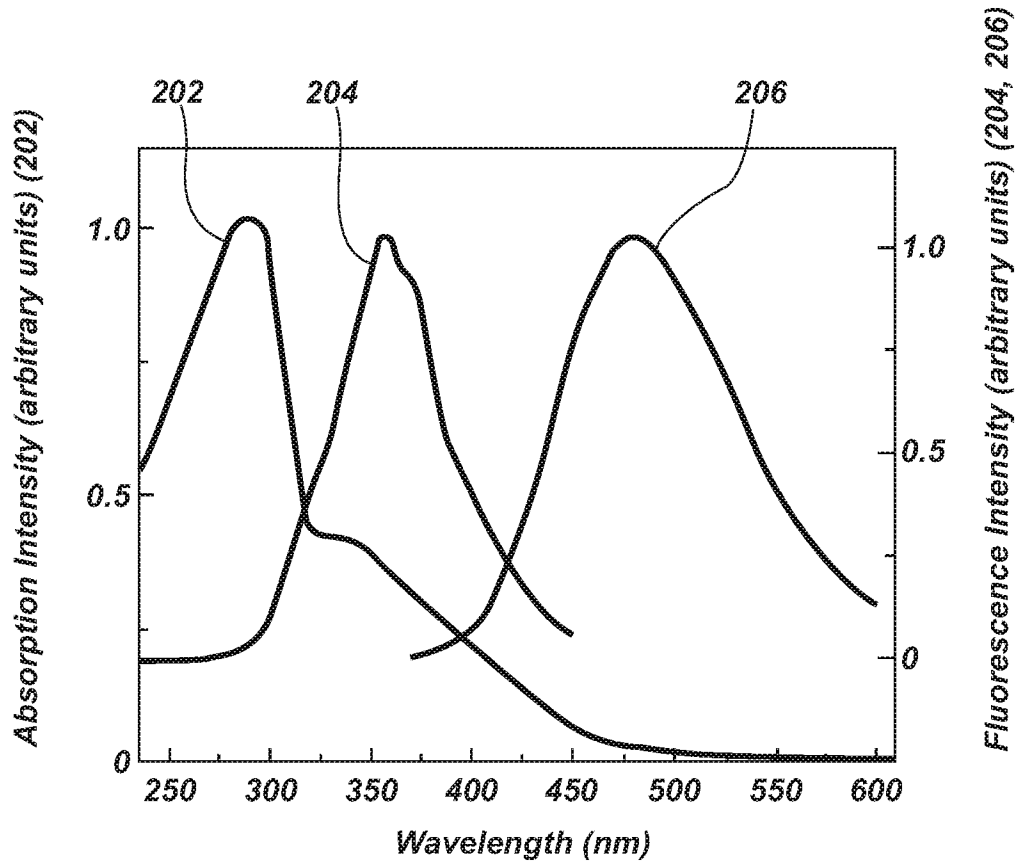

FIG. 3A

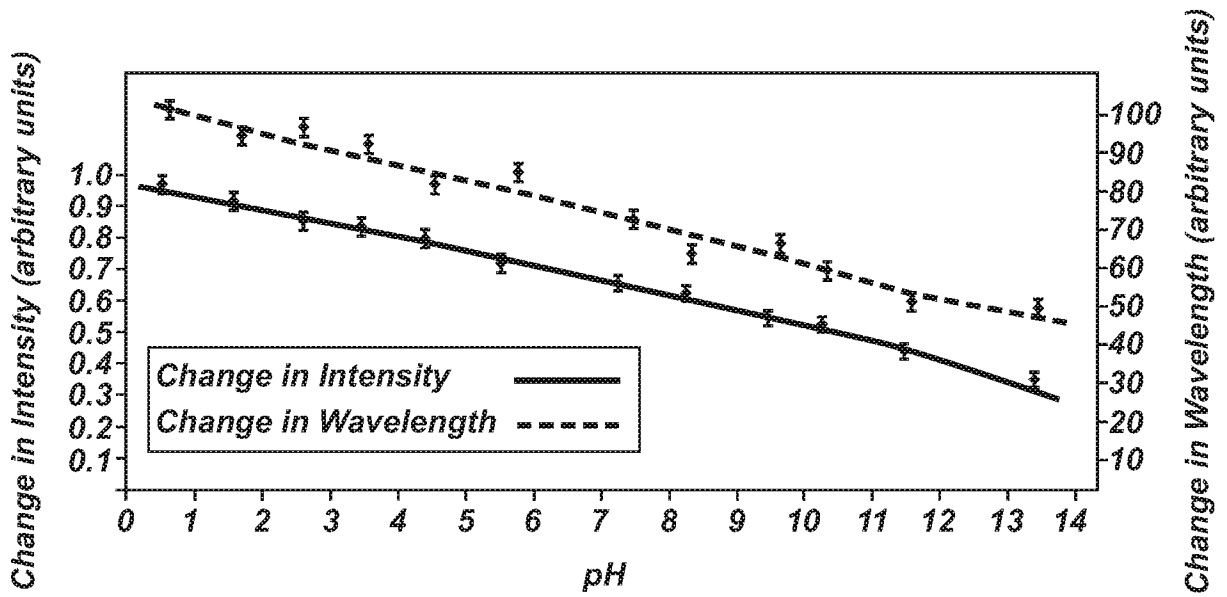

FIG. 3B

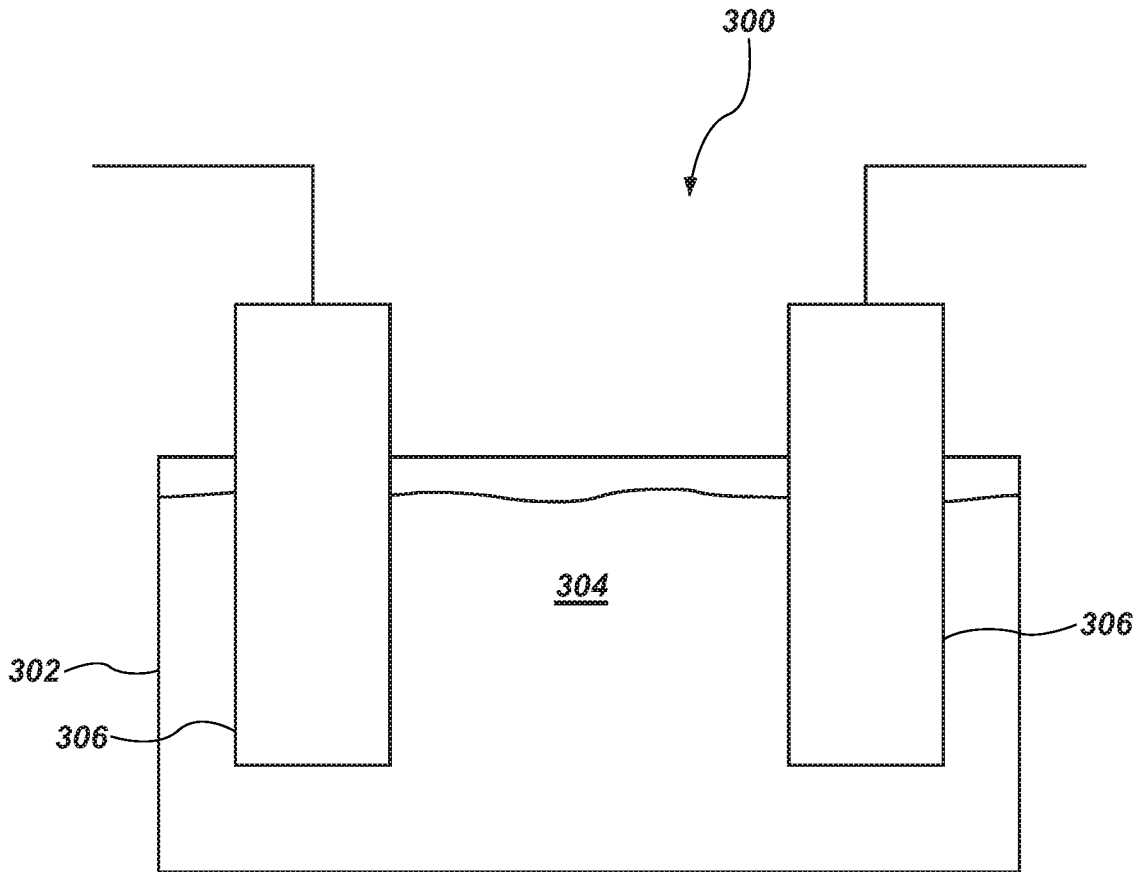

FIG. 4

INTERNATIONAL SEARCH REPORT

International application No
PCT/US2016/036305

A. CLASSIFICATION OF SUBJECT MATTER
INV. E21B47/10
ADD.

According to International Patent Classification (IPC) or to both national classification and IPC

B. FIELDS SEARCHED
Minimum documentation searched (classification system followed by classification symbols)
E21B

Documentation searched other than minimum documentation to the extent that such documents are included in the fields searched

Electronic data base consulted during the international search (name of data base and, where practicable, search terms used)
EPO-Internal, WPI Data

C. DOCUMENTS CONSIDERED TO BE RELEVANT

Category*	Citation of document, with indication, where appropriate, of the relevant passages	Relevant to claim No.
X Y A	US 2012/318503 A1 (KANJ MAZEN Y [SA] ET AL) 20 December 2012 (2012-12-20) paragraphs [0036], [0039]; claims 1,16	1,2,5, 22-24 3,8,9, 12,13, 15-20 4,6,7, 10,11, 14,21
Y	----- US 2011/214488 A1 (ROSE PETER E [US] ET AL) 8 September 2011 (2011-09-08) claims 1,4,5,12,13,22-26,28 -----	3,8,9, 12,13, 15-20

Further documents are listed in the continuation of Box C.

See patent family annex.

* Special categories of cited documents :

- "A" document defining the general state of the art which is not considered to be of particular relevance
- "E" earlier application or patent but published on or after the international filing date
- "L" document which may throw doubts on priority claim(s) or which is cited to establish the publication date of another citation or other special reason (as specified)
- "O" document referring to an oral disclosure, use, exhibition or other means
- "P" document published prior to the international filing date but later than the priority date claimed

- "T" later document published after the international filing date or priority date and not in conflict with the application but cited to understand the principle or theory underlying the invention
- "X" document of particular relevance; the claimed invention cannot be considered novel or cannot be considered to involve an inventive step when the document is taken alone
- "Y" document of particular relevance; the claimed invention cannot be considered to involve an inventive step when the document is combined with one or more other such documents, such combination being obvious to a person skilled in the art
- "&" document member of the same patent family

Date of the actual completion of the international search 14 September 2016	Date of mailing of the international search report 23/09/2016
Name and mailing address of the ISA/ European Patent Office, P.B. 5818 Patentlaan 2 NL - 2280 HV Rijswijk Tel. (+31-70) 340-2040, Fax: (+31-70) 340-3016	Authorized officer Maukonen, Kalle

INTERNATIONAL SEARCH REPORT

Information on patent family members

International application No

PCT/US2016/036305

Patent document cited in search report	Publication date	Patent family member(s)	Publication date	
US 2012318503	A1	20-12-2012	CN 103958643 A	30-07-2014
			EP 2707453 A1	19-03-2014
			US 2012318503 A1	20-12-2012
			US 2015232747 A1	20-08-2015
			US 2015232748 A1	20-08-2015
			US 2015232750 A1	20-08-2015
			US 2015233240 A1	20-08-2015
			US 2015239826 A1	27-08-2015
			WO 2012158478 A1	22-11-2012

US 2011214488	A1	08-09-2011	AU 2011222514 A1	20-09-2012
			EP 2542759 A1	09-01-2013
			US 2011214488 A1	08-09-2011
			WO 2011109782 A1	09-09-2011
