

(No Model.)

2 Sheets—Sheet 1.

F. H. LEWINGTON.
ATTACHMENT FOR SPINNING MULES.

No. 526,015.

Patented Sept. 11, 1894.

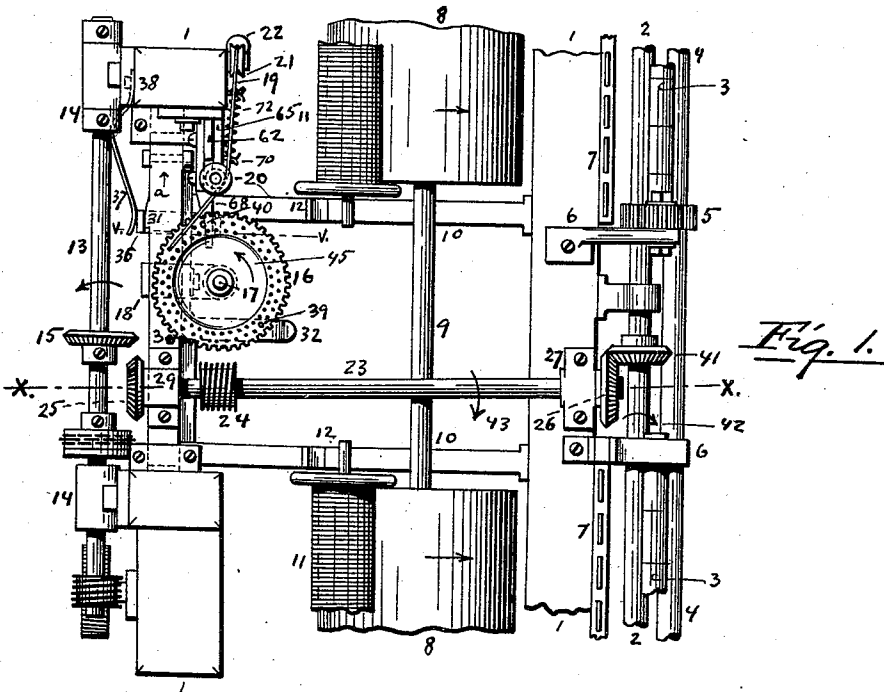

Fig. 1.

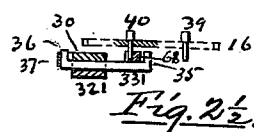

Fig. 2 1/2.

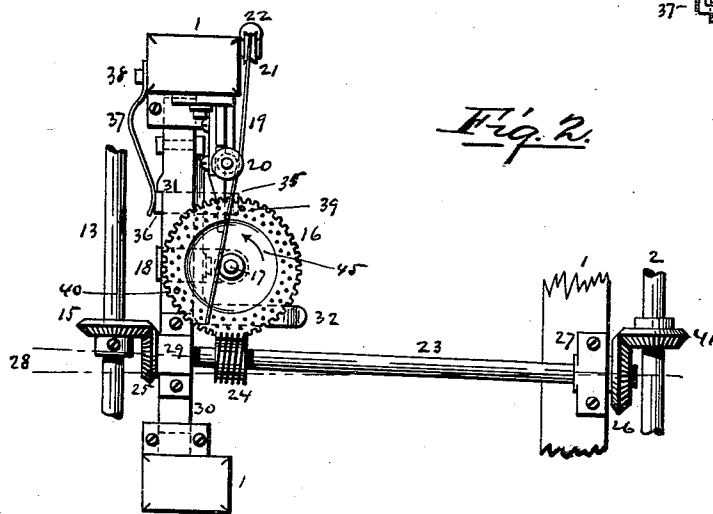

Fig. 2.

Witnesses:

Inventor:

Charles Lammigan
James W. Fink

Frank H. Lewington
By Warren R. Pease
Atty.

(No Model.)

2 Sheets—Sheet 2.

F. H. LEWINGTON. ATTACHMENT FOR SPINNING MULES.

No. 526,015.

Patented Sept. 11, 1894.

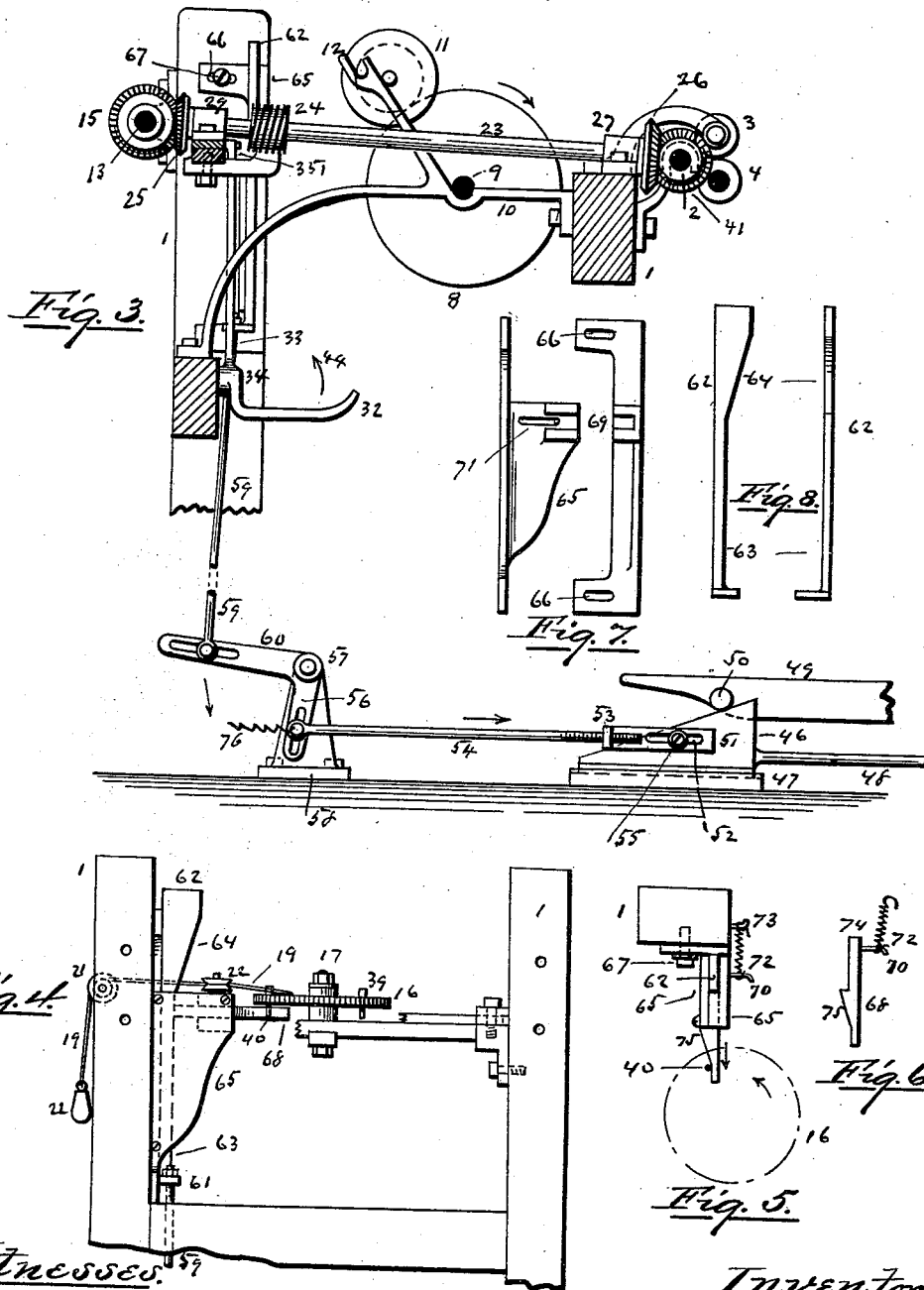

Witnesses:

Inventor:

Charles Hannigan
Louise W. Pink

Frank H. Lewington
 By *Warren R. Pece*
 Atty.

UNITED STATES PATENT OFFICE.

FRANK H. LEWINGTON, OF BURRILLVILLE, RHODE ISLAND.

ATTACHMENT FOR SPINNING-MULES.

SPECIFICATION forming part of Letters Patent No. 526,015, dated September 11, 1894.

Application filed April 2, 1894. Serial No. 506,038. (No model.)

To all whom it may concern:

Be it known that I, FRANK H. LEWINGTON, of Burrillville, in the county of Providence, in the State of Rhode Island, have invented a certain new and useful Improvement in Attachments for Mules; and I declare the following to be a specification thereof, reference being had to the accompanying drawings.

Like numerals indicate like parts.

Figure 1 is a top plan of my invention and so much of a mule-head as is necessary to illustrate the operation of the device. In this figure the roving-wheel is shown out of engagement with the worm-gear. Fig. 2 shows my invention in top plan with the roving-wheel in mesh with the worm-gear. Fig. 3 is a view of my invention, as seen partly in side elevation and partly in section on line *xx* of Fig. 1. Fig. 4 is a side elevation of the roving-wheel in position and of the taper-slides regulating the movements of the same. Figs. 2½, 5, 6, 7 and 8 are detail views.

My invention is an attachment for spinning mules, and has for its object the variable, consecutive and automatic adjustment of the roving-wheel to regulate the length of roving paid by the rollers to be drawn and twisted for the purpose of producing a yarn of uniform size and weight; and it consists of the novel construction and combination of the parts hereinafter particularly specified and set forth in the claims, whereby a stop-slide is automatically moved by devices intermediate between the building-shoe and the roving-wheel to give a variable rotation to the latter for said purpose.

In the drawings, the frame of the mule-head is represented by 1, 1. The rolls are shown at 2, 3, 4 and are driven by the gears 5, as usual. These rolls are mounted in the bearings 6. The guides for the roving are seen at 7. The drums 8 turn on the drumshafts 9, which are mounted on the supports 10, and the spools 11, having their axes supported on the roving-stands 12, rest upon the drums 8. The twist-shaft 13 is mounted in bearings 14, which extend from the frame 1 and has the bevel gear 15.

The roving-wheel 16 has a toothed edge and a series of holes, circumferentially arranged. Said wheel is mounted rotatably upon a stud

17, on a bracket 18. A leather strap or rope 19, fastened in one of the holes of the wheel 16, passes over the pulleys 20 and 21, and a weight 22 is secured to its end.

A worm-shaft 23, having a worm-gear 24 and bevel gears 25, 26, is mounted at one end in a bearing 27, upon the frame 1, so loosely as to allow of a slight horizontal oscillation, the limits of which oscillation are shown in Fig. 2 by the solid lines of said shaft and the dotted lines 28. The opposite end of the worm-shaft 23 is mounted in a bearing 29 upon the sliding bar 30. The sliding bar 30 has a projection 31, whose longitudinal edge is beveled and said bar has a reciprocating motion. This motion in the direction indicated by the arrow *a* is caused by the contact of a rod from the carriage, (not shown,) which moves to and under the arm 32 of a bell-crank lever 33, which is pivoted at 34 to the frame 1, the upright arm of which bell-crank lever is pivotally connected at 35, to the sliding bar 30. The reverse motion is caused by a spring beneath said bar. (Not shown.) The bar 30 slides upon the piece 321. (See Fig. 3.)

A locking bar 331, passing through a slot in the piece 321, (see Fig. 2½,) has two flanges at its ends, as seen at 35 and 36, and a spring 37, fastened at 38 to the frame 1, has its free end pressing against the flange 35.

A pin 39 is thrust through the selected hole in the roving-wheel 16 and a pin 40 is thrust through another of the holes of the said wheel. The roll 2 has a bevel gear 41 engaged with the bevel gear 26 of the worm-shaft 23.

All the parts thus far described are old and well-known and the operation is as follows: The bevel gear 41 of the roll 2, rotating in the direction shown by the arrow 42 turns the bevel gear 26 of the worm-shaft 23 in the direction indicated by the arrow 43. When the arm 32 of the bell-crank lever 33 is raised in the direction shown by the arrow 44, the upright arm of said bell-crank lever moves the sliding bar 30 in the direction indicated by the arrow *a*, which movement of the sliding bar 30 brings the worm-gear 24 into engagement with the roving-wheel 16 and the bevel gear 25 into engagement with

the bevel gear 15 of the twist shaft 13. This movement of the sliding bar 30 also carries its projection 31 past the flange 36 of the locking bar 331, as seen in Fig. 1, until said projection clears said locking bar, whereupon (as seen in Fig. 2), the spring 37 crowds the locking bar against the sliding bar 30 and said locking bar by its contact with the plane edge of said projection locks the sliding bar in the position shown in Fig. 2. The roving-wheel 16 is partially rotated in the direction indicated by the arrow 45 until its pin 39 is brought into forcible contact with the flange 35 of the locking bar 331 and pushes said bar outwardly, whereupon the sliding bar 30 moves by force of the spring beneath it, (not shown,) and the bar with its projection moves to the position shown in Fig. 1, thus disengaging the bevel gears 15, 25, and the roving-wheel from the worm-gear 24. The roving-wheel 16, being thus forced from the worm-gear, is returned to its former position by the weight 22, which draws the strap 19.

To these old elements, so combined, I add the following devices and connect them to the building-shoe: In Fig. 3, 46 represents one of the building-shoes. It is movable in its guides 47 upon the floor and is drawn as usual by the rod 48. Upon said shoe, the coping rail 49, by its stud-pin 50, rises and falls to regulate the formation of the cop or bobbin, in the well-known manner. To this shoe 46 I attach the bar 51, having a slot 52 and a flange 53, and through the latter a rod 54 is adjustable by a screw-thread. A stud 55 passes through the slot 52 into the shoe 46. The rod 54 is adjustably mounted in the slotted arm 56 of a bell-crank lever, which is pivotally mounted at 57 to a stand 58. A rod 59 is adjustably mounted on the other slotted arm 60 of said bell-crank lever and at its upper end is adjustably connected, as shown at 61, to the vertical taper-slide 62. This slide 62 has the perpendicular edge 63 and the wedge face or tapering edge 64. (See Figs. 8 and 4.) It is held by supports 65, which through slots 66 are adjustably mounted in the frame 1 by bolts 67. A horizontal taper-slide or stop 68 is mounted upon the supports 65 between guides 69 and a pin 70 extends from said slide 68 through a slot 71 in one of said supports. A spring 72 is attached at one end to said pin 70 and at the other end to a pin 73 extending from the frame 1. This taper-slide or stop-piece 68 has a straight edge 74 at its outer end and a taper or wedge face 75. A spring 76 attached to the end of the rod 54 gives the rods 54, 59 and their connected parts the return motion.

The operation of my device is as follows: The parts being in the position shown in Fig. 1, the worm-gear is thrown into engagement, as in Fig. 2, by the means already described, and the roving-wheel 16 is partially rotated to the position shown in Fig. 2. When, upon the disengagement of the roving-wheel 16 from the worm-gear 24, the said wheel is given

its reverse motion by the strap 19 and weight 22, the pin 40 strikes against the taper-slide 68. Now, as the building-shoe 46 is moved in the usual manner in its guides 47 and it reaches a position where the stud pin 55 comes into contact with the end of the slot 52 of the bar 51, it pulls the rod 54, which rocks the bell-crank lever 56, 60, which draws down the rod 59 and this pulls down the vertical taper-slide 62, the inclined edge 64 of which crowds the horizontal taper-slide or stop-piece 68 and this movement causes the slide 68 to move outwardly so that its inclined edge 75 comes into the path of the pin 40. The farther out this slide 68 is moved, the shorter is the arc of movement of the roving-wheel 16 in both its rotations, back and forth, and the distance of this outward travel of the slide 68 is regulated by the downward movement of the vertical taper-slide 62, which brings its inclined edge 64 against the inner end of the slide, the spring 72 serving to draw said slide into snug and constant contact with the vertical taper-slide. When the bobbins are beginning to fill, the position of said taper-slides 62 and 68 are as shown in the several figures; but as the bobbins are built up toward their tops the building-shoes, moved by the usual mechanism, (not shown,) pull the rods 54, 59, and draw down the taper-slide 62, which crowds out the slide 68, thereby diminishing the arc of oscillation of the roving-wheel 16. When the bobbins have been filled and a new set is put on, the parts of the device are returned to their first position by the movement of the shoes to their first position in the usual manner.

It is obvious that the arc of rotation of the roving-wheel 16, included between the first position of the pin 39 (Fig. 1) and the second position of said pin (Fig. 2), determines the time and extent of the engagement of the worm-gear 24 with the roving-wheel 16, and also the time and extent of the engagement of the bevel gears 15, 25. As the bevel gear 15 of the twist-shaft 13, when in mesh with the bevel gear 25 of the worm-shaft 23, turns said shaft 23, and by the engagement of the bevel gears 26 and 41, the worm-shaft turns the roll 2, the time and extent of the rotation of the roll 2 and the rolls 3, 4 connected therewith by the gears 5 are regulated by the arc of rotation of the roving-wheel 16. The less that arc, the shorter is the length of roving paid out by the rolls 2, 3, 4 from the spools 11. The shorter the length of roving paid out, the more is it drawn by the traverse of the mule-carriage. Therefore, the yarn which is wound upon the top portion of the bobbin, instead of being heavier than the yarn already wound on the lower portions of the bobbin, is drawn more on account of this variation in the length of roving paid out and the result is that this portion of the yarn, instead of being heavier, as heretofore, is of the same size and weight as the other portions of the yarn. This uniformity in the

yarn gives a superior finish and shading to the cloth and more evenness of texture.

The top portion of a bobbin is apt to be improperly wound, sometimes because the yarn slips off over the top end of the bobbin, sometimes because there is a slack in the roving at the end of the traverse of the carriage, which slack is not sufficiently taken up by the fallers, and for other causes. Various efforts have been made to remedy this defect, but without success hitherto. My device gives a greater length of yarn from a given amount of material than has before been possible, and at the same time secures evenness of size and weight throughout the entire length of the yarn.

By variation of the adjustment of the rods 54 and 59 on the arms 56 and 60 of the bell-crank lever, the speed of the movement of my device can be regulated, and by means of the adjustments on the other ends of the rods, the movements of the taper-slides, relatively to the cop-building mechanism, can be accurately timed.

While I prefer the means as shown to communicate motion from the shoe 46 to the slides 62, 68, it is obvious that other means which are mechanical equivalents, may be employed for that purpose.

I claim as a novel and useful invention and desire to secure by Letters Patent—

1. In a spinning mule the combination of a movable cop-building shoe and an oscillating roving-wheel having a stop-pin, of a horizontal slide, having a tapering edge and movable in guides into the arc of the oscillation of said stop-pin, a vertically mounted slide, having a tapering edge in operative contact with the end of said horizontal slide, a slotted bar upon said shoe, movable on a pin extending from said shoe, a bell-crank lever, a rod connecting the bell-crank lever with said slotted bar, and a rod connecting the bell-crank lever with said vertical slide, for the purpose of limiting and regularly diminishing the arc of

the oscillation of the stop pin and roving-wheel, substantially as described.

2. In a spinning mule the combination of a movable cop-building shoe and an oscillating roving-wheel having a stop-pin, of a horizontal slide, having a tapering edge and movable in guides into the arc of the oscillation of said stop-pin, a vertically mounted slide, having a tapering edge in operative contact with the end of said horizontal slide, a slotted bar upon said shoe, adjustable on a pin extending from said shoe and provided with a screw-threaded flange, a bell-crank lever, having slotted arms, a rod having a screw-threaded end by which it is connected with the slotted bar upon the shoe and adjustably connected at its opposite end with the slotted arm of the bell-crank lever, and a rod adjustably connected with the other slotted arm of the bell-crank lever at one end and at its other end adjustably connected with said vertical slide, substantially as specified.

3. In a mule for spinning, the combination of the geared roving-wheel 16, having the stops 39, 40, the weighted strap 19, the swinging shaft 23, having the worm-gear 24, the sliding bar 30, on which said shaft is mounted, the bell-crank lever 33 adapted to move said bar by the lever arm 32, when the latter is raised, the bell-crank lever 56, 60, suitably mounted, the building shoe 46, the slotted bar 51 and stud 55, the rod 54 connecting the bar 51 and the arm 56 of the bell-crank lever, the rod 59 connecting the arm 60 of the bell-crank lever and the vertical tapering slide 62, the vertical tapering slide 62 mounted on a proper support, the horizontal tapering stop 68 mounted on said support and movable by said slide 62, all operating substantially as and for the purposes specified.

FRANK H. LEWINGTON.

Witnesses:

WARREN R. PERCE,
DANIEL W. FINK.