

Oct. 8, 1935.

E. R. EICHNER

2,016,421

TOOL RACK

Filed Dec. 13, 1933

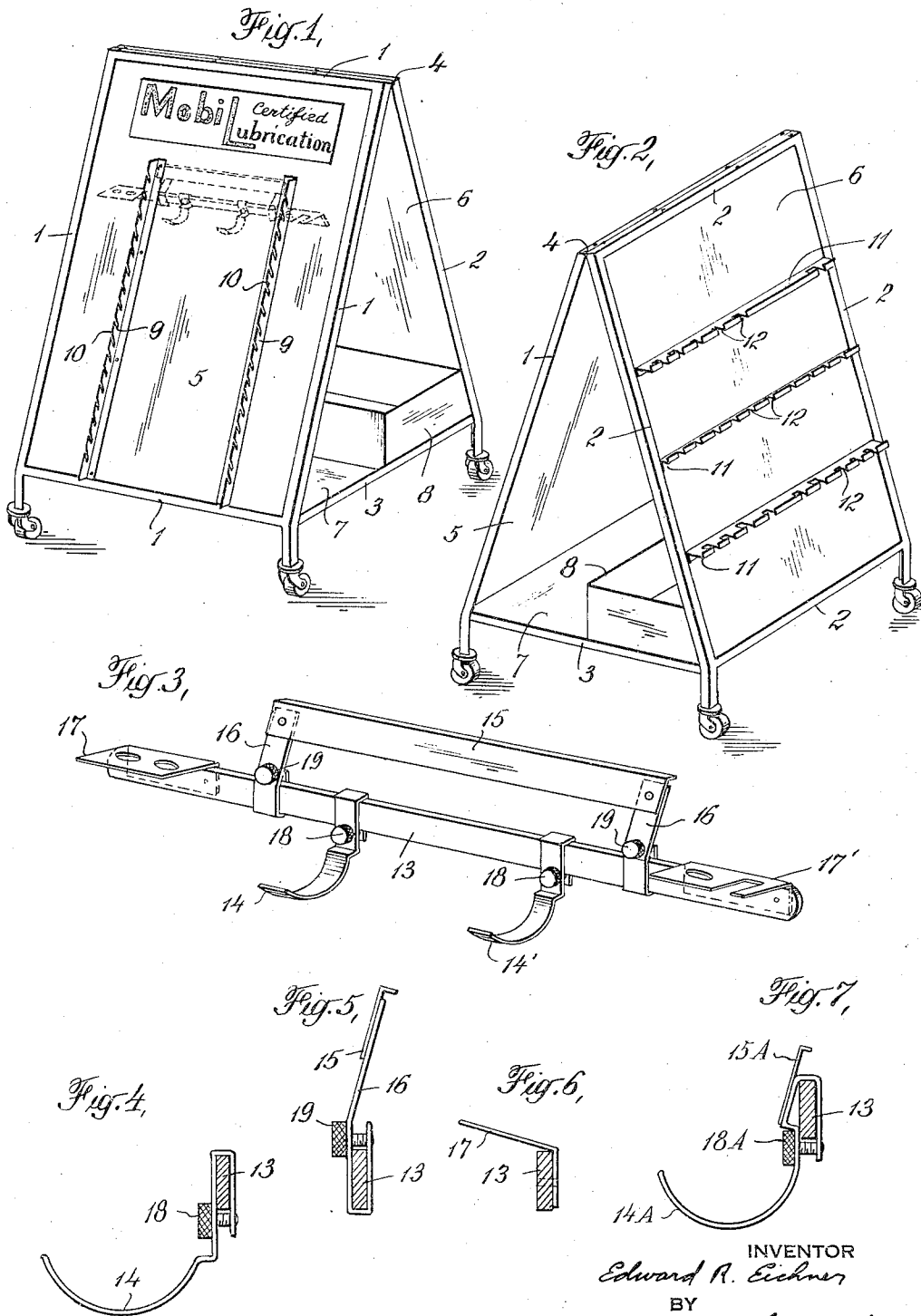

INVENTOR  
Edward R. Eichner  
BY  
Dallas R. Lamont  
ATTORNEY

# UNITED STATES PATENT OFFICE

2,016,421

## TOOL RACK

Edward R. Eichner, Montclair, N. J., assignor to  
Socony-Vacuum Oil Company, Incorporated,  
New York, N. Y., a corporation of New York

Application December 13, 1933, Serial No. 702,123

2 Claims. (Cl. 211—160)

The present invention relates to portable racks for arranging and displaying tools and keeping them in order for selection and use. Specifically, it has to do with a rack adapted for the numerous tools and greasing appliances used in the greasing of automobiles in service stations and the like.

Proper servicing of an automobile with lubricants and greases requires the use of a number of grease guns, each carrying a different kind of grease for a different use, and possibly each fitted with differing attachment means for the servicing of different portions of the machine. In addition, there are required numerous tools of more ordinary kinds for various purposes connected with the work.

In order that the required tools might always be at hand conveniently when wanted, it has long been customary to supply racks upon which these tools might be placed. These racks afford convenient display surface when properly designed, and it has been customary to make use of this display surface for advertising the products or service offered. In the case of organizations selling at widely distributed points, it is important that the advertising, in size, kind and type of display, be uniform. It follows that the basic design of the tool racks should be uniform.

The tool requirements of any particular station are apt to vary, a station whose trade on the average is of high priced cars, may require a very different assortment of tools from one serving a different class of trade. In order to place the required tools upon the standard board, under these conditions, it frequently was required to make each board a specially arranged layout, and standardization at best could not be carried beyond several types of layout.

To properly solve the problem of standard equipment for large companies of wide spread distribution and necessity for many assortments of tools, with high interchangeability of equipment, it has been desirable to devise a standard rack, capable of wide variation in type and placing of tool holding equipment.

It has therefore been an object of this invention to supply a universal tool rack adapted to carry a variable number of special tool holders in variable positions. A further object has been the provision of specialized tool holders for use with said rack. Further objects have been the provision of a tool rack of the utmost flexibility in number and type of tools supported, adaptability to change in type of tools and their number, ready portability, and such other objects and advantages as may hereinafter appear.

All of these objects and advantages have been attained by the design of rack which I disclose here, which can be more readily understood by reference to the drawing attached to and forming a part of this specification.

In the drawing, Figure 1 is an isometric view of the front and one side of the rack, Figure 2 is a similar view of the back of the rack. Figure 3 is a view of one of the special tool holders, and Figures 4, 5, 6 and 7 are various sections explanatory of details of the tool holder.

In general form, my tool rack consists of two rectangular planes joined along their edges at the top and held spaced apart at the bottom, with tool holding devices upon either face.

In Figure 1, the rack is seen to consist of two rectangular frames of light angle iron, the one in front designated by 1—1—1—1, and the rear frame by 2—2, etc. The frames are held in a spaced apart relationship near the bottom by bars 3, and are joined at the top by a long narrow plate 4, fastened to the top member of each frame. The front frame is covered with a sheet panel 5 of steel, and the rear frame with a similar panel 6. Forming a floor for the interior space between the panels 5 and 6, a panel of sheet steel 7 is fastened between the lower horizontals of 1 and 2 and bars 3. On this floor there is placed a box 8, constructed of sheet metal, for receiving the odds and ends of small fittings, etc., which it may be convenient to have at hand, the interior position of the box serving largely to conceal it. On the front panel 5, for the support of the grease guns and similar tools to be placed here, I have provided two panel rails 9 and 9'. These rails are formed of angle iron, and the upstanding leg of the bar is provided with a series of notches 10. These notches serve to receive the special tool holder, which is later explained, and this arrangement permits me to mount any reasonable number of grease guns and the like in any desirable order upon the face of the tool rack.

The back view, Figure 2, shows a plurality of small tool holders 11, fastened upon the panel 6. These small tool holders are formed of a sheet of metal bent into a Z shape, one leg being fastened against the panel, the other two cooperating as shown and being provided with a series of assorted notches, 12, in order that tools may be supported by them.

At each of the four corners of the rack the appropriate frame members are extended in the manner shown and fitted with swivelled wheels for portability.

The largest, most important, most frequently

used, and from a display standpoint the most attractive and most interesting tools used in conjunction with this board are the grease guns. These are accordingly displayed upon the front.

5 In form they are cylindrical of body, two to three inches in diameter, and ten to eighteen inches long. To support these I have provided a special tool support, an isometric view of which is shown in Figure 3. In this figure, 13 is a carriage bar adapted to extend between the two rails 9 and 9' on the front of the tool rack (Figure 1) and to rest in and be engaged by the notches in those rails. Attached near the middle portion of bar 13 are two curved bracket arms, 14 and 14'.  
 10 These arms are formed to provide a socket wherein a grease gun may be placed and are secured to bar 13 in such manner that they may be positioned any distance along it in a manner best suited to the length of the grease gun to be supported. Above the bar 13 there is a sign plate 15, supported by two arms 16 and 16'. This sign may carry a name, a number, a color, or other indicia to indicate the use of the gun belonging in the particular holder. It is my practice to use a name, or number. At either end of the bar 13 there are plates 17 and 17', provided with suitable holes and notches wherein special small fittings, such as adapters and the like to be used with the particular gun supported by the carriage, may be placed.  
 30

Figure 4 shows a sectional view of a portion of the special tool holder, giving more detail of the tool support bars 14, and showing the manner in which they are fastened upon carriage bar 13 by means of screws 18.

Figure 5 shows a section through the special tool holder with detail of the sign 15, its support 16, and their engagement with bar 13 by means of screw 19.

Figure 6 is a section taken thru the fitting bracket 17, showing how it is formed and posi-

tioned with respect to the bar 13, to which it is secured preferably by spot welding.

Figure 7 is a section of a slightly different form of tool holder, taken at the point indicated by 7-7 on Figure 3, which differs only in that a different style of gun bracket and sign are made use of. This form of tool holder is designed for the smaller guns, such as "suction" and "water" guns, and the support bar 14A is curved to a slightly smaller radius, and formed to provide a surface to which a sign 15A may be spot welded or otherwise fastened. The bars 14A are held to bar 13 by a screw 18A as before.

In the use of the tool rack, any suitable number of special tool holders of either type may be placed upon the front panel to receive the assortment of guns desired.

I claim:

1. In an easel-formed display rack for automotive lubricating tools, a pair of vertically aligned rails mounted in spaced relation on one face thereof, a plurality of slots in each of said rails, and, cooperating with said rails, one or more tool-holders, each comprising a horizontal bar adapted to extend from rail to rail and to be supported in the slots therein, a plurality of curvilinear tool-cradle formed arms so mounted on said bar, as to be variably positionable along its length, and on each arm, adjustable friction means to hold said arm in a selected position on said bar.

2. A tool carriage adapted to be supported between aligned spaced supporting members and to hold a tool of bulky cylindrical form comprising a horizontal bar, a plurality of curvilinear tool-cradle formed arms so mounted on said bar as to be variably positionable along its length, and on each arm, adjustable friction means to hold said arm in a selected position on said bar.

EDWARD R. EICHNER.