

R. LUCKENBACH.  
 CONCENTRATING AMALGAMATOR.  
 APPLICATION FILED DEC. 3, 1910.

999,814.

Patented Aug. 8, 1911.

FIG. 1.

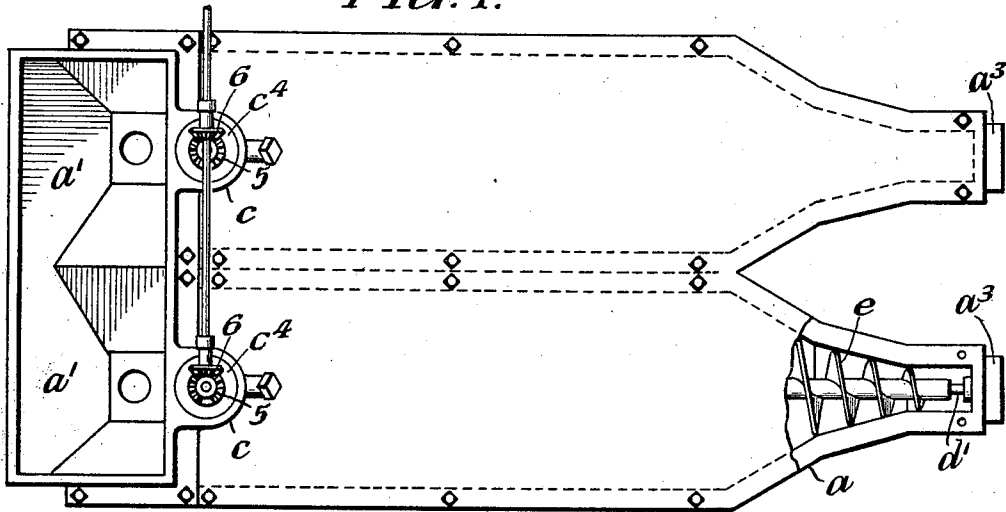

FIG. 2.

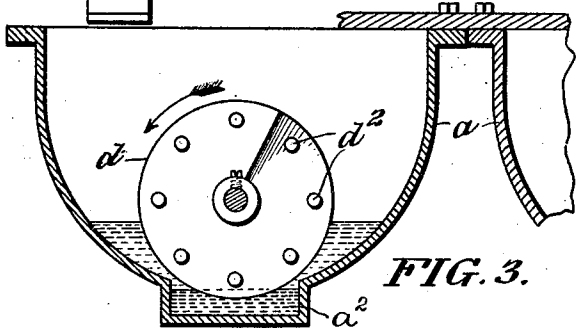
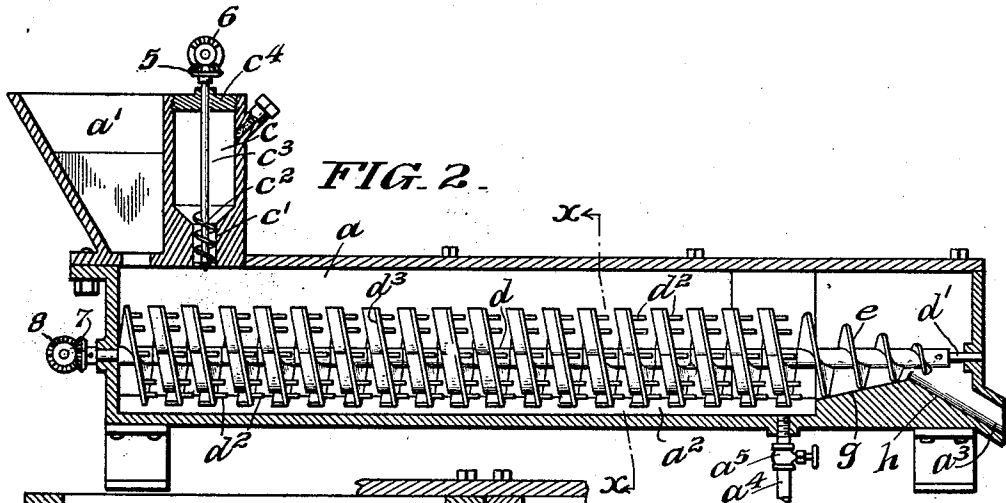

FIG. 3.

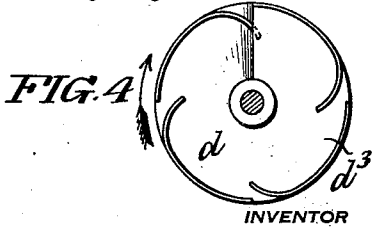

FIG. 4.

INVENTOR

*Roger Luckenbach*

BY

*J. Walter Douglas*

ATTORNEY

WITNESSES  
*Thomas M. Smith*  
*Elizabeth A. Pheldrake*

# UNITED STATES PATENT OFFICE.

ROYER LUCKENBACH, OF COLWYN, PENNSYLVANIA.

CONCENTRATING-AMALGAMATOR.

999,814.

Specification of Letters Patent.

Patented Aug. 8, 1911.

Application filed December 3, 1910. Serial No. 595,361.

To all whom it may concern:

Be it known that I, ROYER LUCKENBACH, a citizen of the United States, residing at Colwyn, in the county of Delaware and State of Pennsylvania, have invented certain new and useful Improvements in Concentrating-Amalgamators, of which the following is a specification.

My invention has relation to an agitating and concentrating amalgamator arranged to recover entrained values of wet metallic ore or pulp presented thereby to a compound forming an amalgam of mercury to quicken the recovery of entrained values; and further to liberate mechanically and by gravity tailings or gangue from the recovered values of the wet ore or pulp; and in such connection my invention relates to the constructive arrangement of such an apparatus for not only economically and efficiently concentrating the entrained ore values in the compound of the apparatus but also mechanically amalgamating the same with such compound, and successively mechanically lifting and by gravity discharging the tailings or gangue therefrom.

The nature, scope and characteristic features of my invention will be more fully understood from the following description taken in connection with the accompanying drawings forming part hereof, in which—

Figure 1, is a top or plan view partly broken away of a concentrating-amalgamator embodying main features of my said invention. Fig. 2, is a vertical longitudinal section through an amalgamator, showing in elevation, the internal arrangement thereof. Fig. 3, is a vertical sectional view on the lines,  $x, x$  of Fig. 2, showing the pin formation in one face of each agitating, lifting and concentrating spiral member; and Fig. 4, is an elevational view of the other face of each agitating, lifting and concentrating spiral member showing the concentrically arranged blades curved to form lifting scoops.

Referring to the drawings,  $a$  is an oblong tank provided with a closed top, as shown. This tank at one extremity portion is provided with a feed hopper  $a^1$ , and adjacent thereto is arranged a container  $c$ , to receive a compound of cyanid of potassium and caustic potash, which in a pulverized condition is fed in controlled quantity from the container into a body of mercury or other similar substance placed in a long trough  $a^2$ ,

formed in the bottom of the tank  $a$ , as clearly illustrated in Figs. 2 and 3, to hasten attraction as well as recovery in conjunction with the mercury or amalgam formed thereby of the entrained values of wet metallic ore or pulp. The container  $c$ , is provided with a screw-feed  $c^2$ , located in the outlet throat  $c^1$ , of the container, the stem  $c^3$ , of which, extends through a removable cap  $c^4$ , and carries a miter-gear 5, meshing with a similar gear 6, for operating the same, from any suitable source of power, not shown. In the forward portion of the casing  $a$ , beyond the trough  $a^2$ , is provided a hump, having reversely inclined sections  $g$  and  $h$ ; the latter leading to a discharge spout  $a^3$ , as shown in Fig. 2. In one portion of the trough  $a^2$ , is provided a pipe  $a^4$ , having a stop-cock  $a^5$ , to lead the mercury or amalgam with recovered values from the wet ore or pulp of the trough  $a^2$ , there-through for subsequent separation of values therefrom.

$d$ , is the spirally arranged agitating, lifting and concentrating device of my invention mounted on and secured to a longitudinal shaft  $d^1$ , extending through the casing  $a$ . This device, consists of a long series of spiral members, each having in one face pins  $d^2$ , and in the other face concentrically arranged blades  $d^3$ , curved to form lifting scoops for the deposited wet ore, pulp or other matter into the trough  $a^2$ , for hastening concentrating by amalgamation of the same with the amalgam mass of said trough  $a^2$ . At the right hand end portion of the shaft  $d^1$ , is mounted a gradually decreasing screw-member  $e$ , extending over the discharge spout  $a^3$ , as clearly illustrated in Fig. 2, whereby through the combined operation of the series of spiral members of the device  $d$ , wet ore or pulp agitated thereby and lifted by the member  $e$ , will be thoroughly concentrated by amalgamation with the mass in the trough  $a^2$ , and values entrained therein, while the tailings or gangue will be liberated by the screw-member  $e$ , over the hump and discharged by gravity through the spout  $a^3$ , from the apparatus. At stated intervals, the entrained values in the body of mercury or amalgam in the trough  $a^2$ , can be drawn off through the pipe  $a^4$ , by opening the stop-cock  $a^5$ , thereof.

From the foregoing description, it will be understood that the wet ore or pulp deposited in the hopper  $a^1$ , will be discharged

through the contracted throat thereof in the path of the series of members of the rotary device *d*, when actuated by the gears 7 and 8, from a suitable source of power, not shown. By the rotations of the device *d*, the ore or pulp, will be agitated, lifted and concentrated in the body of mercury or amalgam and by the screw-member the tailings or gangue successively at intervals lifted over the hump and by gravity discharged into and through the spout *a*<sup>3</sup>, away from the apparatus.

Having thus described the nature and objects of my invention, what I claim as new and desire to secure by Letters Patent is:—

1. A concentrating-amalgamator provided with a rotatable longitudinal shaft carrying a series of spiral members, each having in one face pins and in the other concentrically arranged blades curved to form lifting scoops and means mounted on said shaft and operating in unison with said spiral members, to mechanically lift and discharge matter.

2. A concentrating-amalgamator, comprising a casing provided with a trough to contain a mercury compound or amalgam, said casing formed with a hump and discharge spout, a rotatable longitudinal shaft extending through said casing, a concentrating and amalgamating device, mounted

thereon and consisting of a series of spiral members, each having in one face pins and in the other blades curved to form lifting scoops and a screw-member mounted on said shaft and operating in unison with said device to mechanically lift matter over said hump and discharge the same by gravity into and through said spout.

3. A concentrating-amalgamator, comprising a casing having a feed hopper, a container, a trough and a hump having reversely inclined sections and a discharge spout, a longitudinal shaft extending through said casing and carrying a rotatable concentrating and amalgamating device, consisting of a series of spiral members, each having in one face pins projecting therefrom and in the other blades arranged to form lifting scoops and a screw member mounted on said shaft and operating in unison with said device to mechanically lift matter over said hump and discharge the same by gravity into and through said spout.

In witness whereof, I have hereunto set my signature in the presence of two subscribing witnesses hereto.

ROYER LUCKENBACH.

Witnesses:

THOMAS M. SMITH,  
ELISABETH A. SHELDIAHE.