

May 16, 1967

L. J. BILODEAU

3,319,917

HOOK BRACKET FOR APERTURED BOARD

Filed Aug. 31, 1966

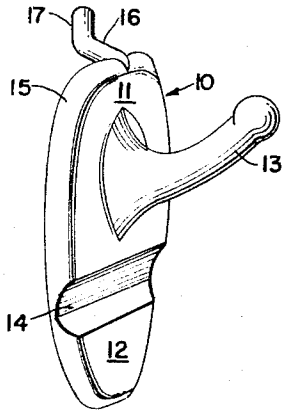

FIG. 1.

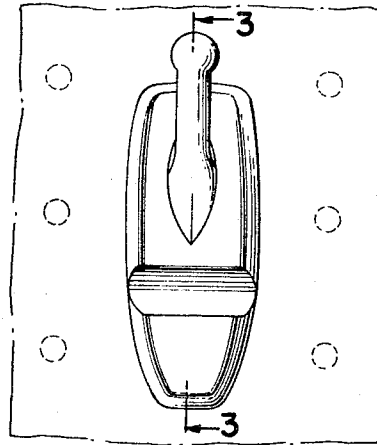

FIG. 2.

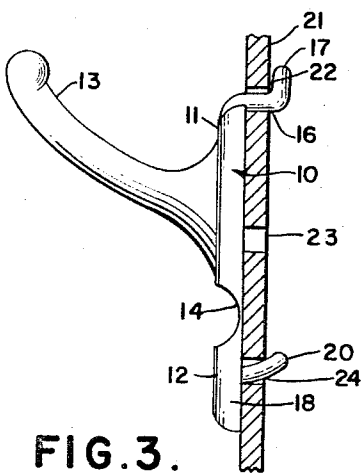

FIG. 3.

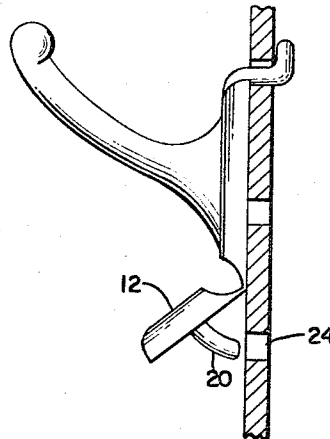

FIG. 4.

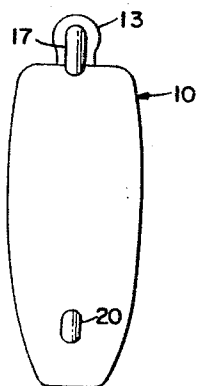

FIG. 5.

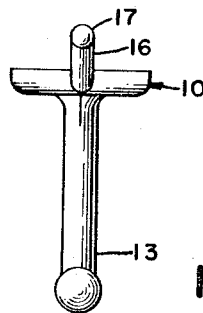

FIG. 6.

INVENTOR

Lucien J. Bilodeau

BY *Holeombe, Wetherill & Briscois*

ATTORNEYS

1

3,319,917

HOOK BRACKET FOR APERTURED BOARD

Lucien J. Bilodeau, 71 Orange St., Barre, Vt. 05641

Filed Aug. 31, 1966, Ser. No. 576,293

2 Claims. (Cl. 248—225)

This invention relates to a method of mounting a bracket on an apertured board.

Various attempts have been made to provide locking means so as to hold a bracket on an apertured board. These have usually consisted of a separate latching means mounted on the upper and lower part of the bracket to engage and hold two engageable holes in the apertured board. These separate locking means have many disadvantages, the principal one being that they become disassociated with the bracket and are not available for use when desired. Such locking means are shown in United States Patents Nos. 3,241,799 and 2,961,724.

It is an object of the present invention to provide a unitary bracket for mounting on an apertured board.

It is also an object of the present invention to provide a bracket having an upstanding gripping means associated with the top thereof and an upstanding gripping means associated with the bottom portion thereof.

It is a still further object of the invention to provide a unitary bracket mounted on an apertured board that is so constructed as to allow the insertion of an upstanding support on the upper end thereof and an upstanding support on the lower end thereof.

The various features of novelty which characterize this invention are pointed out with particularity in the claims annexed to and forming part of this specification. For a better understanding of the invention, however, its advantages, and specific objects obtained with its use, reference should be had to the accompanying drawings and descriptive matter in which have been illustrated and described a preferred embodiment of the invention.

In the drawings:

FIGURE 1 is a perspective view of the bracket.

FIGURE 2 is a front view of the bracket mounted on an apertured board.

FIGURE 3 is a side view partially in section, taken on line 3—3 of FIGURE 2, showing the bracket in the locked position.

FIGURE 4 is a view similar to FIGURE 3, showing the bracket in the unlocked position.

FIGURE 5 is a rear view of the bracket, shown in FIGURE 1.

FIGURE 6 is a top profile view of the bracket shown in FIGURE 1.

A bracket 10 comprises an upper front surface 11 and a lower front surface 12, the surface 11 having a protruded rigid hook 13 made integral therewith. The upper portion 11 and the lower portion 12 have the thin section 14 therebetween. This thin section 14 acts as a hinge, allowing lower portion 12 to move under force with respect to the upper portion 11. Protruding rearwardly from the upper marginal face of the upper portion 11 is the support bar 16 having its extreme outer end 17 returned upwardly forming an upper retaining hook. The length of the portion 16 must be at least the thickness of the apertured board to which it is to be attached. The lower surface 12 has the marginal portion

2

18 defining the lower portion of the bracket 10. Integrally with the rear face and upstanding from the rear surface thereof is a curved hook portion 20, the center of curvature of this hook portion being the thin section 14 and the hook portion 20 being an arc of the circle having its center at said thin section 14. The said thin section may be from 30 to 50 thousandths of an inch and semi-circular in form depending on the composition of the plastic from which it is molded. Polypropylene and polyethylene have both given satisfactory results depending on the amount of plasticizer used.

When mounting the bracket 10 on the apertured board 21, having apertures 22, 23 and 24 arranged in parallel alignment through said board, the bracket 10 is so placed that the outer end 17 of the upper hook is received by and passes through the opening 22, then the support bar 16 is received in the opening 22 and upon forcing the bracket 10 downwardly it assumes the position shown in FIGURE 4. The curved hook 20 assumes a position shown in FIGURE 4 and upon forcing the lower surface 12 downwardly the curved hook 20 is received in and held by the opening 24, as shown in FIGURE 3. The support bar 16 of the upper hook and the curved hook 20 grip the body portion of the apertured board so as to hold the bracket 10 in contact therewith and prevents the movement of the bracket due to the reception of a weighted object on the hook 13.

There are many advantages to mounting a device of any type on an apertured board by means of two hooks on the back of the device which will protrude through and overlap the back surface of the apertured board. This method of mounting holds the device in close contact therewith and prevents movement of the device on the surface of the board regardless of the type of force applied, that is, the device will retain its position on the board even if the force is up, down or sidewise.

In the hook used as an example in this application all of the stress produced by loading the hook 13 is transmitted through the bracket to the hook portions and therethrough to the apertured board. The upper hook has the supporting portion 16 and the outer end portion 17 extending upwardly when used in conjunction with the lower curved hook 20 which also extends upwardly in the same direction as the portion 17 of the upper hook, these hooks being a portion of the integral bracket 10.

While in accordance with the provisions of the Statute, the best forms of embodiment of this invention now known have been illustrated and described, it will be apparent to those skilled in the art that changes may be made in the forms of the apparatus disclosed, without departing from the spirit of this invention, as set forth in the appended claims; and in some cases certain features of this invention may be used to advantage without a corresponding use of other features.

What is claimed is:

1. A bracket for use in combination with an apertured panel, said apertured panel having opposed face surfaces, and having spaced apertures therethrough, said bracket having an upper and a lower hook,
 - (a) the upper hook comprising an elongated support member with an upwardly protruding outer end,
 - (b) said unitary bracket having a thin section therein between the upper and lower hooks,

3

(c) and the lower curved hook being upwardly curved and rotatable about the center of the thin section adapted to be received in and held by a second aperture in said apertured panel.

2. A bracket as set forth in claim 1, wherein said upwardly curved lower hook is an arc of a circle having its center at the center of the thin section.

4

References Cited by the Examiner

UNITED STATES PATENTS

2,765,998	10/1956	Engert	-----	248—467
2,988,315	6/1961	Saxe	-----	248—223
3,163,392	12/1964	Husted	-----	248—223
3,222,023	12/1965	Schweitzer	-----	248—225

5
 CLAUDE A. LE ROY, *Primary Examiner*.