

(No Model.)

2 Sheets—Sheet 1.

J. S. SCHOONOVER.  
FAN BLOWER.

No. 447,909.

Patented Mar. 10, 1891.

Fig. 1.

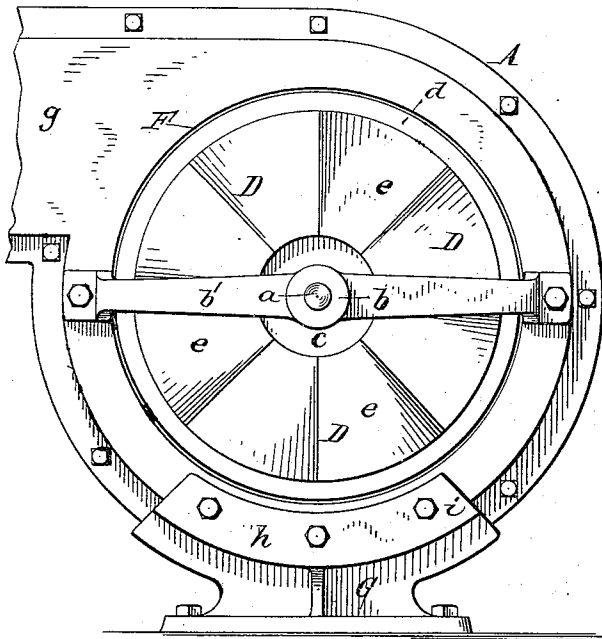

Fig. 2.

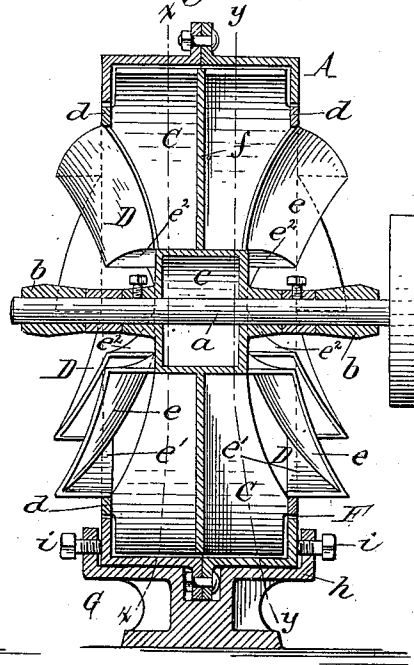
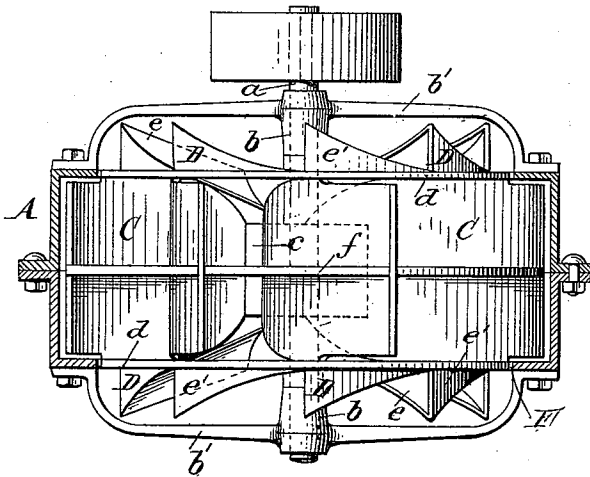

Fig. 3.



Witnesses:  
 Theo. S. Poppo  
 Geo. B. Reichert Jr.

J. S. Schoonover Inventor.  
 By Wilhelm W. Hornet  
 Attorneys.

J. S. SCHOONOVER.  
FAN BLOWER.

No. 447,909.

Patented Mar. 10, 1891.

*Fig. 4.*

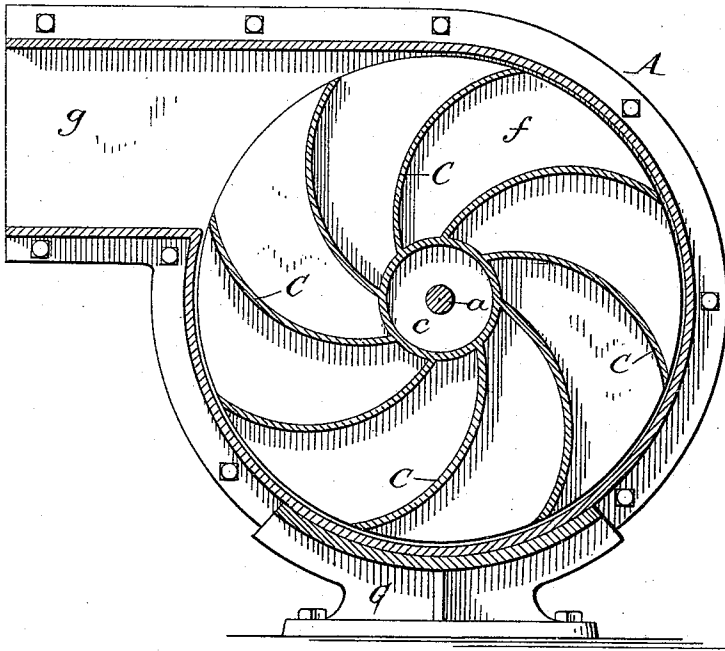

*Fig. 5.*

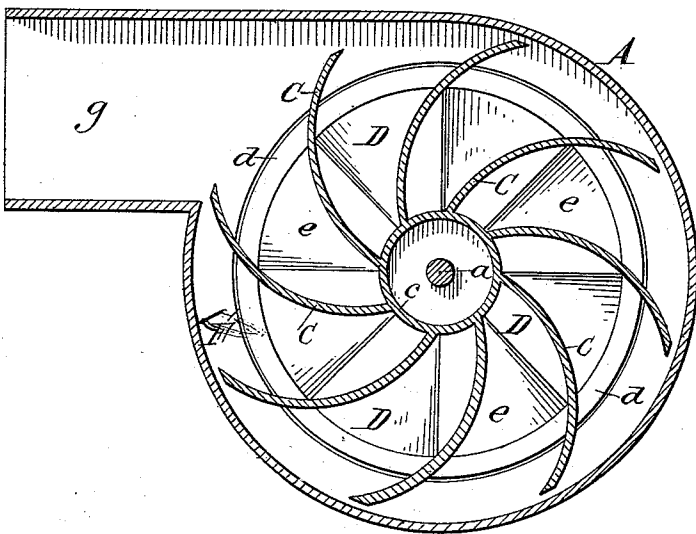

Witnesses:  
*Theo. L. Poppo*  
*Geo. Buschheit Jr.*

*J. S. Schoonover* Inventor,  
 By *Wilhelm Bonnet*  
 Attorneys.

# UNITED STATES PATENT OFFICE.

JAMES S. SCHOONOVER, OF BUFFALO, NEW YORK; ASSIGNOR TO CHARLES F. WHITCHER, OF SAME PLACE.

## FAN-BLOWER.

SPECIFICATION forming part of Letters Patent No. 447,909, dated March 10, 1891.

Application filed July 21, 1888. Serial No. 280,649. (No model.)

*To all whom it may concern:*

Be it known that I, JAMES S. SCHOONOVER, of the city of Buffalo, in the county of Erie and State of New York, have invented new and useful Improvements in Fan-Blowers, of which the following is a specification.

This invention relates to an improvement in that class of fans in which the action of the blades whereby the air is expelled tangentially from the fan-case is supplemented by injecting-buckets, whereby the air is injected into the fan-case between the blades.

The object of my invention is to increase the capacity of the fan by increasing the efficiency of the injecting-buckets and to render the construction of the fan simple and durable.

In the accompanying drawings, consisting of two sheets, Figure 1 is a side elevation of my improved blower. Fig. 2 is a vertical cross-section of the blower. Fig. 3 is a top plan view of the blower with the casing in section. Figs. 4 and 5 are vertical sections in lines *x x* and *y y*, Fig. 2, respectively.

Like letters of reference refer to like parts in the several figures.

A represents the inclosing casing of the blower, and *a* is the horizontal fan-shaft, which is mounted in bearings *b*, formed in horizontal bridge-pieces *b'*, secured to opposite sides of the casing.

C represents the revolving blades or wings of the fan, which are formed on a hub *c*, secured to the fan-shaft *a* in a well-known manner.

D represents an annular series of air-injecting buckets or deflectors, which are arranged on opposite sides of the fan-blades and which inject the air into the spaces between the fan-blades C, the buckets having a scooping action and compelling the air to enter the fan-casing as the buckets revolve. The air-injecting buckets D extend from the hub *c* outwardly to within a short distance from the outer ends of the fan-blades.

The fan-casing is provided in its sides with circular openings F, within which the air-injecting buckets are arranged and through which the latter project outwardly. These openings F are unobstructed except by the injecting-buckets, so that the air is afforded free access to the interior of the fan-case. The

injecting-buckets are secured with their inner ends to the hub and with their outer ends to rings *d*, which are arranged within the openings F near their periphery and secured to the sides of the fan-blades. Each injecting-bucket consists of a curved side plate *e*, an outer or peripheral end plate *e'*, and an inner or hub plate *e''*. The side plate *e* flares from the hub to the periphery of the fan, and its front edge is located farther outwardly from the side of the fan than its rear edge, so that the side plate inclines inwardly and deflects the air inwardly in a direction parallel with the axis of the fan. The peripheral end plate *e'* of each bucket is curved and triangular in form and arranged with its longest side adjacent to the front edge of the side plate, while the inner or hub plate *e''* is of similar form, but smaller. These end plates prevent the escape of the deflected air at the ends of the side plate and compel the air to enter the fan-case. The entire inner or rear edge of each bucket is open or free, so that the deflected air can freely enter between the fan-blades. The inner end plates *e''* are secured to the hub *c* and the outer end plates *e'* to the rings *d*, which are attached to the outer sides of the fan-blades near their outer ends. The blades or wings C are divided centrally at right angles to the shaft *a*, and the parts of the wings are separated by a disk or partition *f*, formed on or secured to the hub *c*, and extending from the latter to the periphery of the fan. This partition prevents the two air-currents entering opposite sides of the casing in opposite directions from clashing or interfering with each other and weakening the force of the blast, but causes each injected current to supply the fan-blades on the adjacent side of the fan, undisturbed by the current entering the opposite side of the fan, so that the full effect of each set of injecting-blades is utilized.

*g* represents the tangential blast-spout of the fan-case, arranged in the usual manner.

I claim as my invention—

1. In a fan-blower, and in combination with the casing and with the fan-blades therein, of a series of buckets formed, as described, of inclined plates *e*, having free front and rear edges, peripheral end plates *e'*, inner end

plates  $e^2$ , and ring  $d$ , the outer ends of the buckets projecting through central openings in the casing and the inner ends being connected to the hub, all substantially as and for the purposes described.

5 2. In a fan-blower of the class described, a series of buckets, each of which is formed of an inclined plate  $e$ , having free front and rear edges, a peripheral end plate  $e'$ , and an inner

end plate  $e^2$ , these buckets being arranged to and operating substantially as described.

Witness my hand this 18th day of June, 1888.

JAMES S. SCHOONOVER.

Witnesses:

CARL F. GEYER,  
FRED. C. GEYER.