

(12) STANDARD PATENT
(19) AUSTRALIAN PATENT OFFICE

(11) Application No. **AU 2019247776 B2**

(54) Title
Ganged coaxial connector assembly

(51) International Patent Classification(s)
H01R 24/38 (2011.01) **H01R 13/639** (2006.01)
H01R 9/05 (2006.01) **H01R 13/646** (2011.01)

(21) Application No: **2019247776** (22) Date of Filing: **2019.04.04**

(87) WIPO No: **WO19/195504**

(30) Priority Data

(31) Number	(32) Date	(33) Country
62/804,260	2019.02.12	US
62/652,526	2018.04.04	US
62/677,338	2018.05.29	US
62/693,576	2018.07.03	US

(43) Publication Date: **2019.10.10**

(44) Accepted Journal Date: **2023.07.20**

(71) Applicant(s)
CommScope Technologies LLC

(72) Inventor(s)
PAYNTER, Jeffrey D.; FLEMING, James P.; KADAKIA, Bhavin; RABELLO, Jose

(74) Agent / Attorney
Spruson & Ferguson, GPO Box 3898, Sydney, NSW, 2001, AU

(56) Related Art
US 7347745 B1
US 8011977 B2



(51) International Patent Classification:

H01R 24/38 (2011.01) *H01R 13/646* (2011.01)
H01R 9/05 (2006.01) *H01R 13/639* (2006.01)

(21) International Application Number:

PCT/US2019/025712

(22) International Filing Date:

04 April 2019 (04.04.2019)

(25) Filing Language:

English

(26) Publication Language:

English

(30) Priority Data:

62/652,526	04 April 2018 (04.04.2018)	US
62/677,338	29 May 2018 (29.05.2018)	US
62/693,576	03 July 2018 (03.07.2018)	US
62/804,260	12 February 2019 (12.02.2019)	US

(71) Applicant: **COMMSCOPE TECHNOLOGIES LLC**

[US/US]; 1100 CommScope Place SE, Hickory, North Carolina 28602 (US).

(72) Inventors: **PAYNTER, Jeffrey D.**; 229 E. Indiana Street, Momence, Illinois 60954 (US). **FLEMING, James P.**; 15560 Frances Lane, Orland Park, Illinois 60462 (US). **KADAKIA, Bhavin**; 6212 Blue Ridge Drive, Plainfield, IL 60586 (US). **RABELLO, Jose**; 10617 154 Street, Orland Park, IL 60462 (US).

(74) Agent: **CANNON, James R.**; MYERS BIGEL, P.A., PO Box 37428, Raleigh, North Carolina 27627 (US).

(81) Designated States (unless otherwise indicated, for every kind of national protection available):

AE, AG, AL, AM, AO, AT, AU, AZ, BA, BB, BG, BH, BN, BR, BW, BY, BZ, CA, CH, CL, CN, CO, CR, CU, CZ, DE, DJ, DK, DM, DO, DZ, EC, EE, EG, ES, FI, GB, GD, GE, GH, GM, GT, HN, HR, HU, ID, IL, IN, IR, IS, JO, JP, KE, KG, KH, KN, KP, KR, KW, KZ, LA, LC, LK, LR, LS, LU, LY, MA, MD, ME,

(54) Title: GANGED COAXIAL CONNECTOR ASSEMBLY

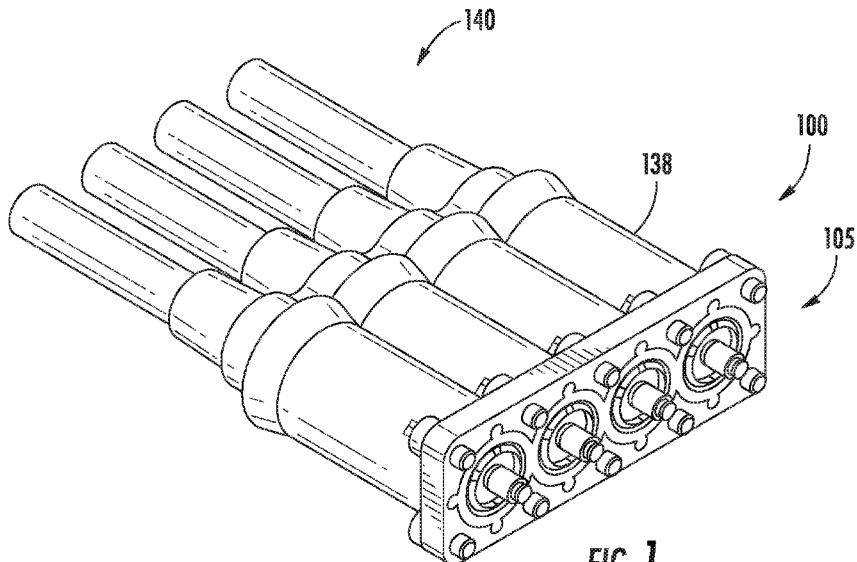

FIG. 1

(57) Abstract: A mated connector assembly includes: a first connector assembly, comprising a plurality of first coaxial connectors mounted on a mounting structure and a first shell; and a second connector assembly, comprising a plurality of second coaxial connectors, each of the second coaxial connectors connected with a respective coaxial cable and mated with a respective first coaxial connector. The second connector assembly includes a second shell surrounding the second coaxial connectors, the second shell defining a plurality of electrically isolated cavities, each of the second coaxial connectors being located in a respective cavity. In a mated condition the second shell resides within the first shell.



MG, MK, MN, MW, MX, MY, MZ, NA, NG, NI, NO, NZ,
OM, PA, PE, PG, PH, PL, PT, QA, RO, RS, RU, RW, SA,
SC, SD, SE, SG, SK, SL, SM, ST, SV, SY, TH, TJ, TM, TN,
TR, TT, TZ, UA, UG, US, UZ, VC, VN, ZA, ZM, ZW.

- (84) Designated States** (*unless otherwise indicated, for every kind of regional protection available*): ARIPO (BW, GH, GM, KE, LR, LS, MW, MZ, NA, RW, SD, SL, ST, SZ, TZ, UG, ZM, ZW), Eurasian (AM, AZ, BY, KG, KZ, RU, TJ, TM), European (AL, AT, BE, BG, CH, CY, CZ, DE, DK, EE, ES, FI, FR, GB, GR, HR, HU, IE, IS, IT, LT, LU, LV, MC, MK, MT, NL, NO, PL, PT, RO, RS, SE, SI, SK, SM, TR), OAPI (BF, BJ, CF, CG, CI, CM, GA, GN, GQ, GW, KM, ML, MR, NE, SN, TD, TG).

Published:

- *with international search report (Art. 21(3))*

GANGED COAXIAL CONNECTOR ASSEMBLY

RELATED APPLICATIONS

[0001] This application claims priority from and the benefit of U.S. Provisional Application Nos. 62/652,526, filed April 4, 2018; 62/677,338, filed May 29, 2018,; 62/693,576, filed July 3, 2018; and 62/804,260, filed February 12, 2019, the disclosures of which are hereby incorporated herein by reference in full.

FIELD OF THE INVENTION

[0002] This invention relates generally to electrical cable connectors and, more particularly, to ganged connector assemblies.

BACKGROUND

[0003] Coaxial cables are commonly utilized in RF communications systems. Coaxial cable connectors may be applied to terminate coaxial cables, for example, in communication systems requiring a high level of precision and reliability.

[0004] Connector interfaces provide a connect/disconnect functionality between a cable terminated with a connector bearing the desired connector interface and a corresponding connector with a mating connector interface mounted on an apparatus or a further cable. Some coaxial connector interfaces utilize a retainer (often provided as a threaded coupling nut) that draws the connector interface pair into secure electro-mechanical engagement as the coupling nut, rotatably retained upon one connector, is threaded upon the other connector.

[0005] Alternatively, connection interfaces may be also provided with a blind mate characteristic to enable push-on interconnection, wherein physical access to the connector bodies is restricted and/or the interconnected portions are linked in a manner where precise alignment is difficult or not cost-effective (such as the connection between an antenna and a transceiver that are coupled together via a rail system or the like). To accommodate misalignment, a blind mate connector may be provided with lateral and/or longitudinal spring action to accommodate a limited degree of insertion misalignment. Blind mated connectors may be particularly suitable for use in “ganged” connector arrangements, in which multiple connectors (for example, four connectors) are attached to each other and are mated to mating connectors simultaneously.

[0006] Due to the limited space on devices such as antennas or radios and the increasing port count required therefor, there may be a need for an interface that increases the density of port spacing and decreases the labor and skill required to make many connections repeatedly.

[0006a] It is an object of the present invention to overcome or ameliorate at least one of the disadvantages of the prior art, or to at least provide a useful alternative thereto.

SUMMARY

[0006b] In an aspect, the present invention provides a mated connector assembly, comprising: a first connector assembly, comprising a plurality of first coaxial connectors mounted on a mounting plate; a second connector assembly, comprising a plurality of second coaxial connectors, each of the second coaxial connectors connected with a respective coaxial cable and mated with a respective first coaxial connector; the second connector assembly including a shell surrounding the second coaxial connectors, the shell defining a plurality of electrically isolated cavities, each of the second coaxial connectors being located in a respective cavity; wherein in a mated condition the shell abuts the mounting plate and each of the first coaxial connectors is mated with a respective second coaxial connector; and wherein the shell and the mounting structure include fastening features that secure the first connector assembly and second connector assembly in the mated condition; and wherein the fastening features comprise a toggle assembly having a pin on the mounting plate and a latch pivotally connected with the shell, wherein the latch engages the pin to secure the mated assembly in position.

[0006c] In another aspect, the present invention provides a mated connector assembly, comprising: a first connector assembly, comprising a plurality of first coaxial connectors and a first shell, each of the first coaxial connectors connected with a respective first coaxial

cable, the first shell defining a plurality of electrically isolated first cavities, each of the first coaxial connectors being located in a respective first cavity, a second connector assembly, comprising a plurality of second coaxial connectors and a second shell, each of the second coaxial connectors connected with a respective second coaxial cable, the second shell defining a plurality of electrically isolated second cavities, each of the second coaxial connectors being located in a respective second cavity; wherein in a mated condition the second shell resides within the first shell, and each of the first coaxial connectors is mated with a respective second coaxial connector; and wherein each of the second coaxial connectors is mounted within its respective second cavity to float radially and axially relative to each of the other second coaxial connectors; wherein each of the first and second shells includes a protrusion that ensures proper orientation of the first and second assemblies during mating; and wherein each of a plurality of springs engages each of the second coaxial connectors and the second shell to provide the axial and radial float between each of the second coaxial connectors and the second shell.

[0006d] In another aspect, the present invention provides a ganged connector assembly, comprising: a first connector assembly, comprising a plurality of first coaxial connectors and a mounting substrate, each of the first coaxial connectors connected with a respective first coaxial cable and mounted on the mounting substrate a second connector assembly, comprising a plurality of second coaxial connectors and a shell, each of the second coaxial connectors connected with a respective second coaxial cable, the shell defining a plurality of electrically isolated cavities, each of the second coaxial connectors being located in a respective cavity; wherein in a mated condition the shell is adjacent the mounting substrate, and each of the first coaxial connectors is mated with a respective second coaxial connector; and wherein each of the second coaxial connectors is mounted within its respective cavity to float radially and axially relative to each of the other second coaxial connectors, wherein each of a plurality of springs engages each of the second coaxial connectors to provide the axial and radial float between each of the second coaxial connectors and the shell; and wherein each of the mounting substrate and the shell includes a feature that ensures proper orientation of the first and second assemblies during mating.

[0007] Also disclosed herein is a mated connector assembly comprising first and second connector assemblies. The first connector assembly comprises a plurality of first coaxial connectors mounted on a mounting structure and a first shell. The second connector assembly comprises a plurality of second coaxial connectors, each of the second coaxial connectors connected with a respective coaxial cable and mated with a respective first coaxial

connector. The second connector assembly including a second shell surrounding the second coaxial connectors, the second shell defining a plurality of electrically isolated cavities, each of the second coaxial connectors being located in a respective cavity. In a mated condition the second shell resides within the first shell.

[0008] Also disclosed herein is a mated connector assembly comprising a first connector assembly and a second connector assembly. The first connector assembly comprises a plurality of first coaxial connectors mounted on a mounting structure. The second connector assembly comprises a plurality of second coaxial connectors, each of the second coaxial connectors connected with a respective coaxial cable and mated with a respective first coaxial connector. The second connector assembly includes a shell surrounding the second coaxial connectors, the shell defining a plurality of electrically isolated cavities, each of the second coaxial connectors being located in a respective cavity. In a mated condition the shell abuts the mounting structure, and each of the first coaxial connectors is mated with a respective second coaxial connector.

[0009] Also disclosed herein is a mated connector assembly comprising first and second connector assemblies. The first connector assembly comprises a plurality of first coaxial connectors and a first shell, each of the first coaxial connectors connected with a respective first coaxial cable, the first shell defining a plurality of electrically isolated first cavities, each of the first coaxial connectors being located in a respective first cavity. The second connector assembly comprises a plurality of second coaxial connectors and a second shell, each of the second coaxial connectors connected with a respective second coaxial cable, the second shell defining a plurality of electrically isolated second cavities, each of the second coaxial connectors being located in a respective second cavity. In a mated condition the second shell resides within the first shell, and each of the first coaxial connectors is mated with a respective second coaxial connector.

[0010] Also disclosed herein is a shell for an assembly of ganged connectors, comprising: a base; a plurality of towers extending from the base, wherein each tower is circumferentially discontinuous and has a gap, each of the towers defining a peripheral cable cavity configured to receive a peripheral cable through the gap; and a plurality of transition walls, each of the transition walls extending between two adjacent towers. The transition walls and the gaps define a central cavity configured to receive a central cable.

BRIEF DESCRIPTION OF THE FIGURES

- [0011] FIG. 1 is a rear perspective view of an assembly of mated ganged coaxial connectors according to embodiments of the invention.
- [0012] FIG. 2 is a top view of the mated assembly of FIG. 1.
- [0013] FIG. 3 is a top section view of the mated assembly of FIG. 1.
- [0014] FIG. 4 is an enlarged section view of the mated assembly of FIG. 1 showing one mated pair of connectors.
- [0015] FIG. 5 is a front perspective view of a ganged equipment connector assembly of the assembly of FIG. 1.
- [0016] FIG. 6 is a rear perspective view of the ganged equipment connector assembly of FIG. 5.

- [0017] FIG. 7 is a rear perspective view of the mounting plate of the ganged equipment connector assembly of FIG. 5.
- [0018] FIG. 8 is a rear perspective view of the outer shell of the ganged equipment connector assembly of FIG. 5.
- [0019] FIGS. 9A and 9B are greatly enlarged partial perspective views of an exemplary mounting screw and its corresponding hole in the mounting plate of the ganged equipment connector assembly of FIG. 5.
- [0020] FIG. 10 is a perspective view of a ganged cable connector assembly of the assembly of FIG. 1 being inserted into the shell of the ganged equipment connectors of FIG. 5.
- [0021] FIG. 11 is a greatly enlarged perspective view of a latch on the housing of the ganged cable connector assembly of FIG. 10.
- [0022] FIG. 12 is a greatly enlarged top view of the latch of FIG. 11 inserted into a slot on the shell of FIG. 8.
- [0023] FIG. 13 is a greatly enlarged partial top section view of the housing and forward end of the outer conductor body of a cable connector of FIG. 10.
- [0024] FIG. 14 is a greatly enlarged partial top section view of the housing and intermediate section end of the outer conductor body of a cable connector of FIG. 10.
- [0025] FIG. 15 is a greatly enlarged partial top section view of the housing and rear end of the outer conductor body of a cable connector of FIG. 10.
- [0026] FIG. 16 is a rear perspective view of an assembly of mated ganged coaxial connectors according to additional embodiments of the invention.
- [0027] FIG. 17 is a front perspective view of the assembly of FIG. 16 with the ganged equipment connectors separated from the ganged cable connectors.
- [0028] FIG. 18 is a front section view of the assembly of FIG. 16.
- [0029] FIG. 19 is a top section view of the ganged cable connectors of the assembly of FIG. 16.
- [0030] FIG. 20 is a top section view of one cable connector of FIG. 19.
- [0031] FIG. 21 is a schematic representation of sixteen assemblies of FIG. 16, illustrating how adjacent assemblies can be intermeshed.
- [0032] FIG. 22 is a perspective view of another assembly of mated ganged connectors according to embodiments of the invention.
- [0033] FIG. 23 is a top section view of the mated assembly of FIG. 22.

[0034] FIG. 24 is an enlarged partial top section view of the mated connectors of FIG. 22.

[0035] FIG. 25 is a front section view of the mated connectors of FIG. 22.

[0036] FIG. 26 is a perspective view of an assembly of mated ganged assembly connectors according to embodiments of the invention with an unmated equipment connector assembly.

[0037] FIG. 27 is a perspective view of an assembly of mated ganged assembly connectors according to additional embodiments of the invention with an unmated equipment connector assembly.

[0038] FIG. 28 is a perspective view of the assembly of FIG. 27 showing how the mated assembly can be secured with a screwdriver.

[0039] FIG. 29 is a perspective view of an assembly of mated ganged assembly connectors according to further embodiments of the invention with an unmated equipment connector assembly.

[0040] FIG. 30 is a section view of another assembly of mated ganged assembly connectors according to embodiments of the invention, wherein springs employed to provide axial float to the connectors of the cable connector assembly are shown in a relaxed position.

[0041] FIG. 31 is a section view of the assembly of FIG. 30, wherein the springs are shown in a compressed position.

[0042] FIG. 32A is a perspective view of another assembly of mated ganged assembly connectors according to embodiments of the invention having a toggle assembly to secure the cable connector assembly to the equipment connector assembly.

[0043] FIG. 32B is a side view of the toggle assembly shown in FIG. 32A with the latch in its unsecured position.

[0044] FIG. 32C is a side view of the toggle assembly shown in FIG. 32A with the latch in its secured position.

[0045] FIG. 33 is a section view another assembly of mated ganged assembly connectors according to embodiments of the invention, with a quarter turn screw employed to secure the cable connector assembly to the equipment connector assembly.

[0046] FIG. 34 is an enlarged section view of the assembly of FIG. 33.

[0047] FIG. 35 is an enlarged perspective view of the mounting hole in the mounting plate of the equipment connector assembly of FIG. 33.

[0048] FIG. 36 is an enlarged opposite perspective view of the mounting hole of FIG. 35.

[0049] FIGS. 37A-37C are sequential views of the insertion and securing of the quarter-turn screw of FIG. 33 in the mounting hole of FIGS. 35 and 36.

[0050] FIG. 38 is a section view of an assembly of mated ganged connectors according to embodiments of the invention showing how the fastening screw is captured by a flap in the housing of the cable connector assembly.

[0051] FIG. 39 is a side view of a connector body for use in an assembly of mated connectors according to embodiments of the invention, wherein the connector body is shown after machining but prior to swaging and cutting.

[0052] FIG. 40 is a side view of the connector body of FIG. 39 after swaging.

[0053] FIG. 41 is a side section view of the connector body of FIG. 39 after swaging and cutting.

[0054] FIG. 42 is a top section view of a mated pair of connectors suitable for use in a mated ganged assembly, the connectors shown in an unmated condition.

[0055] FIG. 42A is a top section view of a mated pair of connectors suitable for use in a mated ganged assembly according to another embodiment, the connectors shown in an unmated condition.

[0056] FIG. 42B is an enlarged partial section view of a portion of the interface of the assembly of FIG. 42A shown in an unmated condition.

[0057] FIG. 42C is an enlarged partial section view of a portion of the outer connector body of the assembly of FIG. 42A shown in an unmated condition.

[0058] FIG. 43 is a top section view of the connectors of FIG. 42 shown in a mated condition.

[0059] FIG. 43A is a top section view of the mated pair of connectors of FIG. 42A, the connectors shown in a mated condition.

[0060] FIG. 43B is an enlarged partial section view of a portion of the interface of the assembly of FIG. 43A shown in a mated condition.

[0061] FIG. 43C is an enlarged partial section view of a portion of the outer connector body of the assembly of FIG. 43A shown in a mated condition.

[0062] FIG. 44 is a perspective view of an assembly of mated ganged connectors according to additional embodiments of the invention.

- [0063] FIG. 45 is a front view of the equipment connector assembly of the assembly of FIG. 44.
- [0064] FIG. 46 is a front perspective view of the shell of the cable connector assembly of the assembly of FIG. 44.
- [0065] FIG. 47 is a rear perspective view of the shell of FIG. 46 with two cables inserted therein.
- [0066] FIG. 48 is a perspective view of an insert to be used with the shell of FIG. 46.
- [0067] FIG. 49 is a perspective section view of the cable connector assembly used in the assembly of FIG. 44 showing the insertion of the insert of FIG. 48 into the shell of FIG. 46.
- [0068] FIG. 50 is an enlarged perspective view of the central cavity of the shell of FIG. 46.
- [0069] FIG. 51 is an enlarged section view of the cable connector assembly of FIG. 49.
- [0070] FIG. 52 is a perspective view of the assembly of FIG. 44 with the shell shown as transparent for clarity.
- [0071] FIG. 53 is partial side section view of the mated assembly of FIG. 44.
- [0072] FIG. 54 is an enlarged partial side section view of the mated assembly of FIG. 53.
- [0073] FIG. 55 is a sectional view of an assembly of mated connectors according to a further embodiment of the invention.
- [0074] FIG. 56 is an enlarged partial section view of the assembly of FIG. 55.
- [0075] FIG. 57 is a sectional view of one pair of mated connectors in an assembly of mated connectors according to a still further embodiment of the invention.
- [0076] FIG. 58 is an end perspective view of the shell of the ganged cable connector assembly employed in the assembly of FIG. 57.
- [0077] FIG. 59 is a sectional view of one pair of mated connectors in an assembly of mated connectors according to a yet further embodiment of the invention.
- [0078] FIGS. 60 and 61 are end views of one connector of the cable connector assembly and the shell of the cable connector assembly of FIG. 58 showing the anti-rotation features of the shell.
- [0079] FIG. 62 is a perspective view of a connector of a ganged cable connector assembly according to still further embodiments of the invention.
- [0080] FIG. 63 is an end view of the connector of FIG. 62 inserted into the shell of FIG. 64.

[0081] FIG. 64 is the shell of the cable connector assembly employing the connector of FIG. 62.

DETAILED DESCRIPTION

[0082] The present invention is described with reference to the accompanying drawings, in which certain embodiments of the invention are shown. This invention may, however, be embodied in many different forms and should not be construed as limited to the embodiments that are pictured and described herein; rather, these embodiments are provided so that this disclosure will be thorough and complete, and will fully convey the scope of the invention to those skilled in the art. It will also be appreciated that the embodiments disclosed herein can be combined in any way and/or combination to provide many additional embodiments.

[0083] Unless otherwise defined, all technical and scientific terms that are used in this disclosure have the same meaning as commonly understood by one of ordinary skill in the art to which this invention belongs. The terminology used in the below description is for the purpose of describing particular embodiments only and is not intended to be limiting of the invention. As used in this disclosure, the singular forms "a", "an" and "the" are intended to include the plural forms as well, unless the context clearly indicates otherwise. It will also be understood that when an element (e.g., a device, circuit, etc.) is referred to as being "connected" or "coupled" to another element, it can be directly connected or coupled to the other element or intervening elements may be present. In contrast, when an element is referred to as being "directly connected" or "directly coupled" to another element, there are no intervening elements present.

[0084] Referring now to the drawings, an assembly of mated ganged connectors, designated broadly at **100**, is shown in **FIG. 1-15**. The assembly **100** includes a ganged equipment connector assembly **105** that includes four coaxial equipment connectors **110**, and a ganged cable connector assembly **140** that includes four coaxial cable connectors **150**. These components are described in greater detail below.

[0085] Referring now to **FIGS. 3 and 4**, each of the equipment connectors **110** includes an inner contact **112**, a dielectric spacer **114** that circumferentially surrounds a portion of the inner contact **112**, and an outer conductor body **116** that circumferentially surrounds the dielectric spacer **114** and is electrically isolated from the inner contact **112**. An O-ring **117** is mounted in a groove in an intermediate section of the outer conductor body **116**.

[0086] A flat plate 120 provides a common mounting structure for the equipment connectors 110. As can be seen in FIG. 7, the plate 120 includes four aligned holes 121, each of which is encircled by a recess 122 on its rear side. The recesses 122 are contiguous with each other. Each recess 122 has two or three pockets 123 extending radially outwardly therefrom that also extend through the thickness of the plate 120. Also, ten holes 130 are arranged near the perimeter of the plate 120.

[0087] Referring now to FIGS. 3-5, a shell 124 is mounted to the plate 120 and extends forwardly therefrom. The shell 124, typically formed of a polymeric material, is generally scalloped in profile, with each “scallop” 125 partially surrounding one of the holes 121. The shell 124 is held in place by posts 128 that extend radially outwardly from the rear edges of the scallops 125 and terminate at rings 126 (see FIG. 8); the rings 126 are received in the recesses 122 of the plate 120, and the posts 128 are received in the pockets 123. Barbs 116a on the outer conductor body 116 assist in holding the shell 120 in place. As can be seen in FIGS. 1, 2 and 8, the two endmost scallops 125 include latch openings 138.

[0088] As seen in FIGS. 8, 9A and 9B, ten access openings 134 are located at the rear edges of the scallops 125, each being aligned with a corresponding hole 130. Screws 136 are inserted through the holes 130 (with access provided by the access openings 134) to mount the plate 120 to electronic equipment, such as a remote radio head. The positions of the access openings 134 and the holes 130 makes it possible to securely mount the plate 120 (and in turn the equipment connector assembly 110) to electronic equipment in a relatively small space.

[0089] The shell 124 may be formed via injection molding, and in particular may be injection molded with the mounting plate as an insert, such that the rings 126 and posts 128 are integrally formed in place during the molding process.

[0090] Referring now to FIGS. 3 and 4, the cable connector assembly 140 includes four cables 142, each of which has an inner conductor 143, a dielectric layer 144, an outer conductor 145 (in this case, the outer conductor is corrugated, but it may be smooth, braided, etc.), and a jacket 146. Each of the cables 142 is connected with one of the connectors 150.

[0091] Each connector 150 includes an inner contact 152, dielectric insulators 154a, 154b and an outer conductor body 156. The inner contact 152 is electrically connected with the inner conductor 143 via a press-fit joint, and the outer conductor body 156 is electrically connected with the outer conductor 145 via a solder joint 148. A spring basket 158 with fingers 158a is positioned within the cavity of the outer conductor body 156.

[0092] A shell 160 circumferentially surrounds each of the outer conductor bodies 156 of the connectors 150, thereby electrically insulating them from each other within cavities 165. A shoulder 161 on the shell 160 is positioned to bear against a shoulder 157 on the outer conductor body 156 (see FIG. 14). A strain relief 162 overlies the interfaces of the cables 142 and connectors 150; barbs 156b on the outer conductor body 156 help to hold the strain relief 162 in place. As can be seen in FIGS. 4 and 13-15, the inner diameter of the shell 160 is slightly larger than the outer diameter of the outer conductor body 156, such that gaps g1, g2 are present. In addition, as shown in FIG. 13, the free end of the outer conductor body 156 extends slightly farther toward the mating connector 110 than the shell 160. FIG. 15 shows that a gap g3 is present between the shell 160 and the strain relief 162.

[0093] As shown in FIGS. 3 and 4, the connectors 110, 150 are mated by inserting the cable connector assembly 140 into the equipment connector assembly 105. More specifically, the shell 160 is inserted within the shell 120, with each of the cavities 165 residing within a respective scallop 125. This action aligns each connector 150 of the cable connector assembly 140 with a respective connector 110 of the equipment connector assembly 105. As is illustrated in FIGS. 3 and 4, the inner contacts 152 of the connectors 150 receive the inner contacts 112 of the connectors 110, and the free ends of the outer conductor bodies 116 are received in the gaps between outer conductor bodies 156 and the spring fingers 158a of the spring baskets 158. Notably, the spring fingers 158a exert radial pressure on the outer conductor body 116 and do not “bottom out” axially against the outer conductor body 116; this is characteristic of some connector interface configurations, such as the 4.3/10, 4.1/9.5, and 2.2/5 interfaces. The cable connector assembly 140 is maintained in place relative to the equipment connector assembly 140 via latches 164 in the shell 160 engaging the latch openings 138.

[0094] As seen in FIG. 13, the free end of the outer conductor body 156 does not reach the plate 120, thereby forming a gap g4 therebetween. The presence of the gaps g3, g4 enable the connectors 150 of the cable connector assembly 140 to shift axially relative to their corresponding mating connectors 110 in the event such shifting is required for mating (e.g., because of manufacturing tolerances and the like). In addition, the presence of the gaps g1, g2 between the outer conductor bodies 156 and the shell 160 enables the connectors 150 to shift radially relative to the connectors 110 in the event such shifting is required.

[0095] Also, as noted above, the shell 160 on the cable connector assembly 140 electrically insulates the connectors 150 from each other, which in turn electrically insulates

the mated pairs of connectors **110, 150** from adjacent pairs. The configuration enables the mated connectors **110, 150** to be closely spaced (thereby saving space for the overall connector assembly **100**) without sacrificing electrical performance.

[0096] The illustrated assembly **100** depicts connectors **110, 150** that satisfy the specifications of a “2.2/5” connector, and may be particularly suitable for such connectors, as they typically are small and are employed in tight spaces.

[0097] Referring now to **FIGS. 16-21**, another embodiment of an assembly of mated ganged connectors, designated broadly at **200**, is illustrated therein. The assembly **200** is similar to the assembly **100** in that an equipment connector assembly **205** with four connectors **210** mates with a cable connector assembly **240** with four connectors **250**.

Differences in the assemblies **105, 205** and in the assemblies **140, 240** are set forth below.

[0098] The equipment connector assembly **205** has a plate **220** that has two recesses **224** in its top and bottom edges and two ears **222** with holes **223** that extend from the top and bottom edges, with each ear **222** being vertically aligned with a respective recess **224** on the opposite edge. The ears **222** and recesses **224** are positioned between adjacent holes **230** in the plate **220**. The cable connector assembly **240** has a shell **260** with four ears **262** with holes **263** that align with ears **222** and holes **223**. Screws **266** are inserted into the holes **263** and holes **223** to maintain the assemblies **205, 240** in a mated condition.

[0099] As can be seen in **FIG. 21**, the plates **220** are configured to nest with adjacent plates **220**. **FIG. 21** schematically illustrates sixteen assemblies **200** arranged in a 4x4 array, wherein the ears **222** of one plate **220** are received in the recesses **224** of an adjacent plate **220**. This arrangement enables adjacent assemblies **200** to be tightly packed, which can save space.

[00100] Referring now to **FIGS. 22-25**, an assembly **300** is shown therein. The assembly **300** includes a first cable connector assembly **305** and a second cable connector assembly **340**. The connectors **310** of the first cable connector assembly **305** are similar to the connectors **110** described above, and the connectors **350** of the second cable connector assembly **340** are similar to the connectors **150** described above. However, the connectors **310** are arranged in a square 2x2 pattern, as are the connectors **350**. The connectors **310** are held in place via a strain relief **320**, a spacer **322** and a housing **324**. Similarly, the connectors **350** and cables **345** are held in place with a strain relief **352**, a spacer **354** and a housing **356** having a panel **358**. The strain reliefs **320, 352** and the spacers **322, 354** enable the connectors **310, 350** to “float” relative to each other to facilitate interconnection. As

shown in **FIG. 24**, when the assembly **300** is fully mated, the free end of the housing **324** of the first cable connector assembly **305** contacts the panel **358** of the housing of the second cable connector assembly **340** to provide an axial stop that prevents the fingers **358a** of the spring basket **358** of the connectors **350** from “bottoming out” against the outer conductor body **316** of the connectors **310**.

[00101] As can be seen in **FIG. 25**, in some embodiments, the housings **324**, **352** of the connector assemblies **305**, **340** include upper portions that are rounded slightly (as compared to the lower portions, which are generally straight). This difference serves as an orientation feature to ensure that the assemblies **305**, **340** are properly oriented relative to each other for mating, which further ensures that the connectors **310**, **350** are each aligned to mate with the correct mating connector.

[00102] Referring now to **FIGS. 26-29**, additional embodiments of ganged connectors are shown therein. **FIG. 26** shows an assembly **400** of an equipment connector assembly **405** of four connectors **410** mounted in a 2x2 array on a mounting plate **420** and a cable connector assembly **440** of four connectors (not visible in **FIG. 26**) and four cables **442**. The connectors **410** are similar to the connectors **110** discussed above, and the connectors of the cable connector assembly **440** are similar to the connectors **140** discussed above. A strain relief **462** surrounds and isolates the connectors of the cable connector assembly **440**; a shell **460** extends forwardly of the strain relief **462**. A mounting hole **464** is located at the center of the strain relief **462** and shell **460**. The shell **460** also includes access openings **466** in its free edge that are positioned to receive screws for the mounting plate **420**.

[00103] As shown in **FIG. 26**, the cable connector assembly **440** mates with the equipment connector assembly **405**, with a connector of the cable connector **440** mating with a corresponding connector **410**. The assemblies **405**, **440** are maintained in a mated condition by a screw or other fastener inserted through the mounting hole **464** and into a mounting hole **426** on the mounting plate **420**. The shell **460** abuts the surface of the mounting plate **420**.

[00104] It should be noted that, when formed of a resilient polymeric or elastomeric material such as TPE, the shell **460** may provide additional strain relief, as well as serving to help to “center” the individual connectors of the cable connector assembly **440**. The resilience of the material biases the individual connectors toward their “centered” position to more easily align with their respective mating connectors **405**. This effect can also help to center the entire cable connector assembly **440**, as the centering of two of the connectors of the cable connector assembly **440** can help to center the whole assembly **440**. In addition, the

shell 460 can also allow the individual connectors to pivot and otherwise shift as needed for alignment.

[00105] Referring now to FIG. 27, another embodiment of an assembly 500 is shown therein. The assembly 500 is similar to the assembly 400 with the exception that the equipment assembly 505 includes connectors 550 mounted to the mounting plate 520 that are similar to the connectors 440, and the cable connector assembly 540 includes connectors that are similar to the connectors 410. As a result, the mounting plate 520 can be formed slightly smaller than the mounting plate 420, thereby saving space on the equipment. FIG. 28 shows how the assemblies 505, 540 can be secured with a screwdriver employed to drive a fastening screw through holes located in the center of the mounting plate 520 and the cable connector assembly 540. FIG. 38 shows an alternative configuration 500' in which a fastening screw 572 is used to connect the equipment assembly 505' to the cable connector assembly 540'. The fastening screw 572 is maintained in position by a flap 574 that encircles the mounting hole 564. The head of the fastening screw 572 is larger than the mounting hole 564, so once the head of the fastening screw 572 passes through the mounting hole 564 (the material of the shell 560' being sufficiently resilient to stretch to enable the head of the screw 572 to pass therethrough), the flap 574 captivates the screw 572 in place. As an alternative, the head of the screw 572 may be captured within the mounting hole 564 itself via an interference fit.

[00106] Referring now to FIG. 29, an assembly 600 comprising an equipment connector assembly 605 and a cable connector assembly 640 is shown therein. This embodiment utilizes a coupling nut 666 that attaches to a threaded ring 622 on the mounting plate 620 to secure the assemblies 605, 640 in a mated condition.

[00107] Referring now to FIGS. 30 and 31, another embodiment of an assembly, designated broadly at 700, is shown therein. The assembly 700 is similar to the assembly 500 discussed above, with one exception being that the connectors 710 mounted in the cable connector assembly 740 include helical springs 780 that encircle each connector 750. The springs 780 extend between the inner surface of the shell 760 and a projection 782 on the outer conductor body 716. The springs 780 enable the connectors 710 to float axially relative to the shell 760.

[00108] As potential alternatives, the spring 780 may be replaced with a Belleville washer, which may be a separate component, or may be insert-molded into the shell 760 (in which case the washer may include a spiked or spoked perimeter for improved mechanical integrity at the joint). The spring 780 may also be replaced with an elastomeric spacer or the like.

[00109] Referring now to FIGS. 32A-32C, another embodiment of an assembly is shown therein and designated broadly at 800. The assembly 800 may be similar to either of the assemblies 400, 500, but includes a toggle assembly 885 with an L-shaped latch 886 mounted to the shell 860 of the cable connector assembly 840 at a pivot 887 and a pin 888 mounted to the mounting plate 820 of the equipment connector assembly 805. A handle 889 extends generally parallel to a finger 890 on the latch 886 and generally perpendicular to an arm 891 that extends between the finger 890 and the pivot 887. The finger 890 includes a recess 895 adjacent the arm 891. The handle 889 includes a slot 896 (see FIG. 32A).

[00110] The latch 886 can be pivoted via the handle 889 into engagement with the pin 888 to secure the assemblies 805, 840 to each other. As the finger 890 initially contacts the pin 888, the handle 889 is relatively easily pivoted toward the latched position. The assembly 800 is fully secured with the toggle assembly 885 when the latch 886 pivots sufficiently that the finger 890 moves relative to the pin 888 so that the pin 888 slides into the recess 895. Because in the secured position the handle 889 is generally level with the pin 888 and generally perpendicular to a line between the pivot 887 and the recess 895, significantly greater mechanical force is required on the handle 889 to move the latch 886 from the recess 895 back to its unsecured position. In the illustrated embodiment, the force required on the handle 889 to move the latch 886 into the secured position may be less than 27 lb-ft, while the force required to move the handle 889 from the secured position may be 50 lb-ft or more, and may even require the use of a screwdriver, wrench or other lever inserted into the slot 896 to create sufficient force. As such, once secured, the assembly 800 will tend to remain in the secured condition.

[00111] Referring now to FIGS. 33-37C, another embodiment of an assembly is shown therein and designated broadly at 900. The assembly 900 is similar to the assembly 500 with the exception that a quarter-turn screw 990 is employed to secure the cable connector assembly 940 to the equipment connector assembly 905. As shown in FIG. 35, a mounting hole 991 in the mounting plate 920 is configured to enable protruding flanges 992 of the quarter-turn screw 990 to be inserted. FIG. 36 shows that, on the opposite side of the mounting plate 920, the mounting hole 991 is surrounded by a circular recess 993 with two additional radially-extending recesses 994. FIGS. 37A-37C illustrate how the quarter-turn screw 990 can be inserted in the mounting hole 991 (FIG. 37A) and rotated a quarter turn (shown in progress in FIG. 37B) so that the flanges 992 are received in the recesses 994 (FIG. 37C).

[00112] Referring again to **FIG. 38**, the assembly **500'** shown therein also includes a metal tube **595** through which the fastening screw **572** may be inserted that provides a positive stop to prevent overtightening of the screw **572**. The assembly **500'** also shows a groove **596** on the inner surface of the shell **560'** that can capture a rim **597** on the housing **524'** to assist with securing of the assemblies **505', 540'**.

[00113] Referring now to **FIGS. 39-41**, an outer conductor body suitable for use in a mated ganged assembly is shown therein and designated broadly at **1056**. The outer conductor body **1056** includes a spring washer-type structure and action that can replace the springs **780** shown in **FIGS. 30** and **31**. As shown in **FIG. 39**, the outer conductor body after machining has a radially-extending fin **1058**. The fin **1058** is swaged or otherwise formed into a truncated conical configuration (shown at **1058'** in **FIG. 40**). The inner diameter of the fin **1058'** is then cut from the remainder of the outer conductor body **1056** (see **FIG. 41**). In this configuration, the fin **1058'** can serve as a spring that allows axial adjustment of the outer conductor body **1056**.

[00114] The process described above can provide a Belleville washer-type spring that may be more suitable than a separate washer, as the inner diameter of the fin **1058'** (which can be an important dimension for achieving a desirable spring action) can be closely matched to the outer diameter of the outer conductor body **1056**.

[00115] Referring now to **FIGS. 42** and **43**, mating connectors **1105, 1150** for another assembly, designated broadly at **1100**, is shown therein. The connectors **1105, 1150** are similar to the connectors of the assembly **700** discussed above, with the accompanying spring **780** to allow axial float. However, the outer conductor body **1156** of the connector **1150** includes a ramped surface **1157** forward of a shoulder **1158**; the spring **1150** is captured between the shoulders **1182, 1158**. The shell **1160** includes a rim **1161** with a ramped inner surface **1162**.

[00116] As can be seen in **FIG. 42**, in an open position, the rim **1161** rests against the forward surface of the shoulder **1158**. As the connector **1150** moves to a mating condition with the connector **1105** as shown in **FIG. 43**, the forward surface of the rim **1161** compresses the spring **1180** against the shoulder **1182**. The ramped surfaces **1157, 1162** interact during mating to gradually center and radially align the connectors **1105, 1150**. In some embodiments, in the closed position there is a slight interference fit between the ramped surfaces.

[00117] This configuration can provide distinct performance advantages. When both of the electrical contacts (inner and outer conductors) of mating connectors are radial, as is the case with 4.3/10, 2/2.5 and Nex10 interfaces, axial clamp force between the mating connectors is not needed for electrical contact directly, but only to provide mechanical stability: specifically, to force the axes of the two mating connectors to remain aligned, thus preventing the electrical contact surfaces from moving relative each other during bending, vibration, and the like. Such relative axial movement can generate PIM directly, and can also generate debris which in turn further causes PIM. (Experiments have demonstrated this behavior for the 4.3/10 interface).

[00118] The two clamped or interfering sections spaced along the outer conductor body **1156** in the closed position of **FIG. 43** provide a means of creating this desired axial stability. Furthermore, the ramped surfaces **1157**, **1162** allow radial float initially and gradually bring the axis of the floating connector (i.e., the connector **1150**) into alignment with the fixed connector (i.e., the connector **1105**) and then hold it in a fixed position when fully advanced. The angle of the ramped surfaces **1157**, **1162** can be adjusted to provide the mechanical advantage required based on the force of the latching mechanism used. In some embodiments, this arrangement may eliminate the need for any axial float, in which case the spring **1180** may be omitted. The area of interference can be increased as required to increase stability at the expense of radial float.

[00119] Referring now to **FIGS. 42A-42C** and **43A-43C**, another assembly, designated broadly at **1100'**, is shown therein. In this embodiment, axial float is provided with a spring **1180'** similar to that shown for the assembly **1100**. However, radial float is controlled differently by the ID and OD of the outer connector bodies **1116'**, **1154'** at the interface and the OD of the rear end of the outer connector body **1154'** and a ramped transition surface **1155'**. As shown in **FIGS. 42A-42C**, in an unmated condition, the connector **1150'** is able to float axially and radially due to the spring **1180'**. However, in the mated condition of **FIGS. 43A-43C**, mating of the outer connector bodies **1116'**, **1154'** tends to radially align the connector **1150'**, and as it floats rearwardly, the ramped transition surface **1155'** forces the rear end of the outer connector body **1154'** into radial alignment. As this occurs, though, there is still the opportunity for axial float at the outer connector body **1154'** moves rearwardly. The clearance at both ends of the outer conductor body **1154'** is sufficiently minimal that this interaction can be used to maintain the mated condition without other external means. (In fact, those skilled in this art will recognize that this concept may be employed with a single

connector pair and is not limited to ganged connectors as illustrated herein). Also, as noted above, in some embodiments the spring 1180' may be omitted, as the resilience of the shell 1160' may provide sufficient give to permit any needed axial float.

[00120] Those of skill in this art will appreciate that the assemblies discussed above may vary in configuration. For example, the connectors are shown as being either "in-line" or in a rectangular MxN array, but other arrangements, such as circular, hexagonal, staggered or the like, may also be used. Also, although each of the assemblies is shown with four pairs of mating connectors, fewer or more connectors may be employed in each assembly. An example of an assembly with five pairs of connectors is shown in FIGS. 44-54 and designated broadly at 1200, which includes an equipment connector assembly 1205 with five connectors 1210 and a cable connector assembly 1240 with five connectors 1250 connected to five cables 1242. As shown in FIGS. 46 and 47, the connectors 1210 and 1250 are arranged in a cruciform pattern, with one of the connectors 1210, 1250 surrounded by four other connectors 1210, 1250 separated from each other by 90 degrees. In this arrangement, one potential issue that can arise is proximity of the connectors. For larger cables and connectors, there may be inadequate space between the connectors 1210 to enable each of the connectors 1250 to have its own cavity as shown in FIG. 26 (either as separate shells or as a single shell with four cavities), as the wall thickness of the material surrounding the cavity is often too thin.

[00121] This shortcoming may be addressed by the use of the shell 1260 shown in FIGS. 46-54. The shell 1260 has a generally square footprint with an outer rim 1262 that surrounds a base 1261. Four towers 1263 extend from the base 1261. Each of the towers 1263 defines a peripheral cavity 1267, but is discontinuous in that it includes a radially-inward gap 1264. Each tower 1263 includes a recess 1265 at one end, with a lip 1265a extending radially inwardly from the front end of the recess 1265 (see FIGS. 53 and 54). A transition wall 1269 spans adjacent towers 1263, with the effect that a central cavity 1266 is defined by the transition walls 1269 and the gaps 1264. Each of the transition walls 1269 includes an indentation 1268 (see FIG. 50).

[00122] Referring now to FIG. 48, an annular insert 1270 is shown therein. The insert 1270 is discontinuous, having a gap 1271 in the main wall 1273. Four blocks 1274 with arcuate external surfaces 1275 extend radially outwardly from the main wall 1273. Snap projections 1276 extend radially outwardly from the main wall 1273 between each pair of adjacent blocks 1274.

[00123] Construction of the assembly 1240 can be understood by reference to FIGS. 47, 49-51, 53 and 54. A terminated cable 1242 with a connector 1250 attached to the end thereof is inserted through the central cavity 1266. The cable 1242 is then forced radially outwardly through one of the gaps 1264 and into the corresponding peripheral cavity 1267, with the tower 1263 being sufficiently flexible to deflect to allow the cable 1240 to pass through the gap 1264. The connector 1250 is located relative to the shell 1260 so that rear end of the outer body 1252 of the connector 1250 fits within the recess 1265 and is captured by the lip 1265a (see FIGS. 53 and 54). This process is repeated three more times until all four of the peripheral cavities 1267 are filled (see FIG. 47, which shows two cables 1240 in place in the shell 1260).

[00124] Next, a fifth terminated cable 1242 is passed through the central cavity 1266 and the connector 1250 is located relative to the shell 1260. The insert 1270 is slipped over the cable 1242 (i.e., the cable 1242 passes through the gap 1271 in the insert 1270) and oriented so that the blocks 1274 fit between the transition walls 1269. The insert 1270 is then slid along the cable 1242 and into the central cavity 1266 (see FIG. 49) until the snap projections 1276 snap into the indentations 1265. This interaction locks the final (central) cable 1242 into place. The cable connector assembly 1240 can then be mated with the equipment connector assembly 1205 as shown in FIG. 52.

[00125] It can be understood that the above-described arrangement, with four cables acting as the “corners” of a “square” and a fifth cable located in the center of the “square,” can provide the assembly with space-related advantages. In particular, cables may be arranged in this manner in a smaller footprint than similar cables arranged in a circular pattern. Similarly, if the same footprint area is employed, large cables may be included in the illustrated “square” arrangement, with can provide performance advantages (such as improved attenuation).

[00126] It will also be understood that the assembly 1240 may be formed with four cables 1242 (one each residing in the peripheral cavities 1267), with the central cavity 1266 being filled with a circular (rather than annular) insert.

[00127] Referring now to FIGS. 55 and 56, another assembly, designated broadly at 1300, is shown therein. The assembly 1300 is similar to the assembly 1200, with an equipment connector assembly 1305 having connectors 1310 and a cable connector assembly 1340 having connectors 1350 and a shell 1360. The cable connector assembly 1340 has two O-rings 1380, 1382 within recesses in the outer conductor body 1356 of the connector 1350 that

provide sealing against the outer conductor body **1316** of the connectors **1310**. Alternatively, as shown in **FIGS. 57** and **58**, an assembly **1400** comprises an equipment connector assembly **1405** and a cable connector assembly **1440** that provides sealing via one O-ring **1480** positioned like the O-ring **1380** and a second O-ring **1485** positioned between the outer conductor body **1456** and the shell **1460**. In these instances, the O-rings are positioned such that they can provide two separate seals between the assemblies to ensure the prevention of water egress into the area of electrical contact between the outer conductor bodies of the connectors. As another alternative, an assembly **1500** is similar to assembly **1400**, but includes a molded-in sealing protrusion **1590** that is part of the shell **1560** rather than the O-ring **1485**.

[00128] Referring now to **FIGS. 60** and **61**, the shell **1460** of the cable connector assembly **1440** shown in **FIG. 58** has cavities **1467** with sections **1468** that are generally hexagonally-shaped, but that have beveled corners **1468a** between the sides **1468b** of the “hexagon.” Put another way, the sections **1468** are 12-sided, with six long sides **1468b** and six shorter sides **1468a**. As shown in **FIGS. 60** and **61**, this arrangement can prevent the connectors **1450** from over-rotating within the cavity **1467** (which can damage the cable and/or produce debris that can negatively impact performance) while still permitting same degree of radial float.

[00129] As another example of addressing the desire for some radial float of the connectors while limiting twist, a connector assembly **1600** is shown in **FIGS. 62-64**. In this embodiment, the connector **1650** of the cable connector assembly **1640** has teeth **1669** on the outer conductor body **1654**, and the shell **1660** has corresponding recesses **1670** (in the embodiment shown herein, the connector **1650** has six teeth **1669**, and the shell **1660** has six recesses **1670**, although more or fewer teeth/recesses may be included). This arrangement also reduces the degree of twist between the connector **1650** and the shell **1660**, which can protect the cable and prevent the production of undesirable debris, but also permits some degree of radial float.

[00130] Those of skill in this art will also recognize that the manner in which mating assemblies may be secured for mating may vary, as different types of fastening features may be used. For example, fastening features may include the numerous latches, screws and coupling nuts discussed above, but alternatively fastening features may include bolts and nuts, press-fits, detents, bayonet-style “quick-lock” mechanisms and the like.

[00131] The foregoing is illustrative of the present invention and is not to be construed as limiting thereof. Although a few exemplary embodiments of this invention have been

described, those skilled in the art will readily appreciate that many modifications are possible in the exemplary embodiments without materially departing from the novel teachings and advantages of this invention. Accordingly, all such modifications are intended to be included within the scope of this invention as defined in the claims. The invention is defined by the following claims, with equivalents of the claims to be included therein.

CLAIMS

1. A mated connector assembly, comprising:
- a first connector assembly, comprising a plurality of first coaxial connectors mounted on a mounting plate;
 - a second connector assembly, comprising a plurality of second coaxial connectors, each of the second coaxial connectors connected with a respective coaxial cable and mated with a respective first coaxial connector;
 - the second connector assembly including a shell surrounding the second coaxial connectors, the shell defining a plurality of electrically isolated cavities, each of the second coaxial connectors being located in a respective cavity;
 - wherein in a mated condition the shell abuts the mounting plate and each of the first coaxial connectors is mated with a respective second coaxial connector; and
 - wherein the shell and the mounting structure include fastening features that secure the first connector assembly and second connector assembly in the mated condition; and
 - wherein the fastening features comprise a toggle assembly having a pin on the mounting plate and a latch pivotally connected with the shell, wherein the latch engages the pin to secure the mated assembly in position.
2. The connector assembly defined in claim 1, wherein the shell includes a plurality of access openings, and the mounting plate includes a plurality of mounting holes, wherein each mounting hole may be accessed via a corresponding access opening.
3. The connector assembly defined in claim 1, wherein each of the second coaxial connectors includes an outer conductor body and a spring basket with spring fingers positioned radially inwardly of the outer conductor body, and wherein each of the first coaxial connectors includes an outer conductor body that engages the spring fingers.
4. The connector assembly defined in claim 1, wherein each of the first coaxial connectors includes an outer conductor body and a spring basket with spring fingers positioned radially inwardly of the outer conductor body, and wherein each of the second coaxial connectors includes an outer conductor body that engages the spring fingers.

5. A mated connector assembly, comprising:
 - a first connector assembly, comprising a plurality of first coaxial connectors and a first shell, each of the first coaxial connectors connected with a respective first coaxial cable, the first shell defining a plurality of electrically isolated first cavities, each of the first coaxial connectors being located in a respective first cavity,
 - a second connector assembly, comprising a plurality of second coaxial connectors and a second shell, each of the second coaxial connectors connected with a respective second coaxial cable, the second shell defining a plurality of electrically isolated second cavities, each of the second coaxial connectors being located in a respective second cavity;
 - wherein in a mated condition the second shell resides within the first shell, and each of the first coaxial connectors is mated with a respective second coaxial connector; and
 - wherein each of the second coaxial connectors is mounted within its respective second cavity to float radially and axially relative to each of the other second coaxial connectors;
 - wherein each of the first and second shells includes a protrusion that ensures proper orientation of the first and second assemblies during mating; and
 - wherein each of a plurality of springs engages each of the second coaxial connectors and the second shell to provide the axial and radial float between each of the second coaxial connectors and the second shell.
6. The mated assembly defined in claim 5, wherein the springs are helical springs.
7. The mated assembly defined in claim 5, wherein the springs are Belleville washer-type springs.
8. The mated assembly defined in claim 5, wherein each of the second coaxial connectors includes an outer conductor body with a ramped surface, and the second shell includes a second ramped surface, and wherein the ramped surfaces engage each other during mating to provide axial stability to the mated assemblies.
9. The mated connector assembly defined in claim 1, wherein the second connectors include a first anti-rotation feature that engages with a second anti-rotation feature on the shell to inhibit rotation of the second connector relative to the shell during mating.

10. The mated connector assembly defined in claim 9, wherein the first anti-rotation feature is a plurality of teeth extending radially outwardly from the second connector, and the second anti-rotation feature is a plurality of recesses that receive the plurality of teeth.
11. The mated connector assembly defined in claim 9, wherein the first and second anti-rotation features are configured to permit radial float of the connector relative to the shell.
12. The mated connector assembly defined in claim 1, wherein the latch includes a finger that engages the pin and an arm merging with the finger and pivotally attached to the second shell, and wherein the toggle assembly further includes a handle attached to the arm.
13. The mated connector assembly defined in claim 12, wherein in the secured position, the finger is generally perpendicular to a line between the pivot and the pin, and the handle is generally parallel with the finger.
14. The mated connector assembly defined in claim 1, wherein the second connectors and the shell are configured so that, in the unmated condition, the second connectors are free to float axially and radially relative to the shell, and in the mated condition, the second connectors are free to float axially relative to the shell but are constrained from floating radially.
15. The mated connector assembly defined in claim 1, wherein when the latch engages the pin, the latch does not extend toward the mounting plate farther than an end of the second shell.
16. The mated connector assembly defined in claim 1, wherein the second shell includes a recess, and wherein the pin is received in the recess.
17. The mated connector assembly defined in claim 1, wherein the second plurality of coaxial connectors is four coaxial connectors, and wherein the four coaxial connectors generally define a square.
18. The mated connector assembly defined in claim 1, wherein the mounting plate comprises a bulkhead of a piece of electronic equipment.

19. The mated connector assembly defined in claim 1, wherein the mounting plate and the shell include registration features that ensure proper orientation of the first and second assemblies during mating.

20. A ganged connector assembly, comprising:

a first connector assembly, comprising a plurality of first coaxial connectors and a mounting substrate, each of the first coaxial connectors connected with a respective first coaxial cable and mounted on the mounting substrate:

a second connector assembly, comprising a plurality of second coaxial connectors and a shell, each of the second coaxial connectors connected with a respective second coaxial cable, the shell defining a plurality of electrically isolated cavities, each of the second coaxial connectors being located in a respective cavity;

wherein in a mated condition the shell is adjacent the mounting substrate, and each of the first coaxial connectors is mated with a respective second coaxial connector; and

wherein each of the second coaxial connectors is mounted within its respective cavity to float radially and axially relative to each of the other second coaxial connectors, wherein each of a plurality of springs engages each of the second coaxial connectors to provide the axial and radial float between each of the second coaxial connectors and the shell; and

wherein each of the mounting substrate and the shell includes a feature that ensures proper orientation of the first and second assemblies during mating.

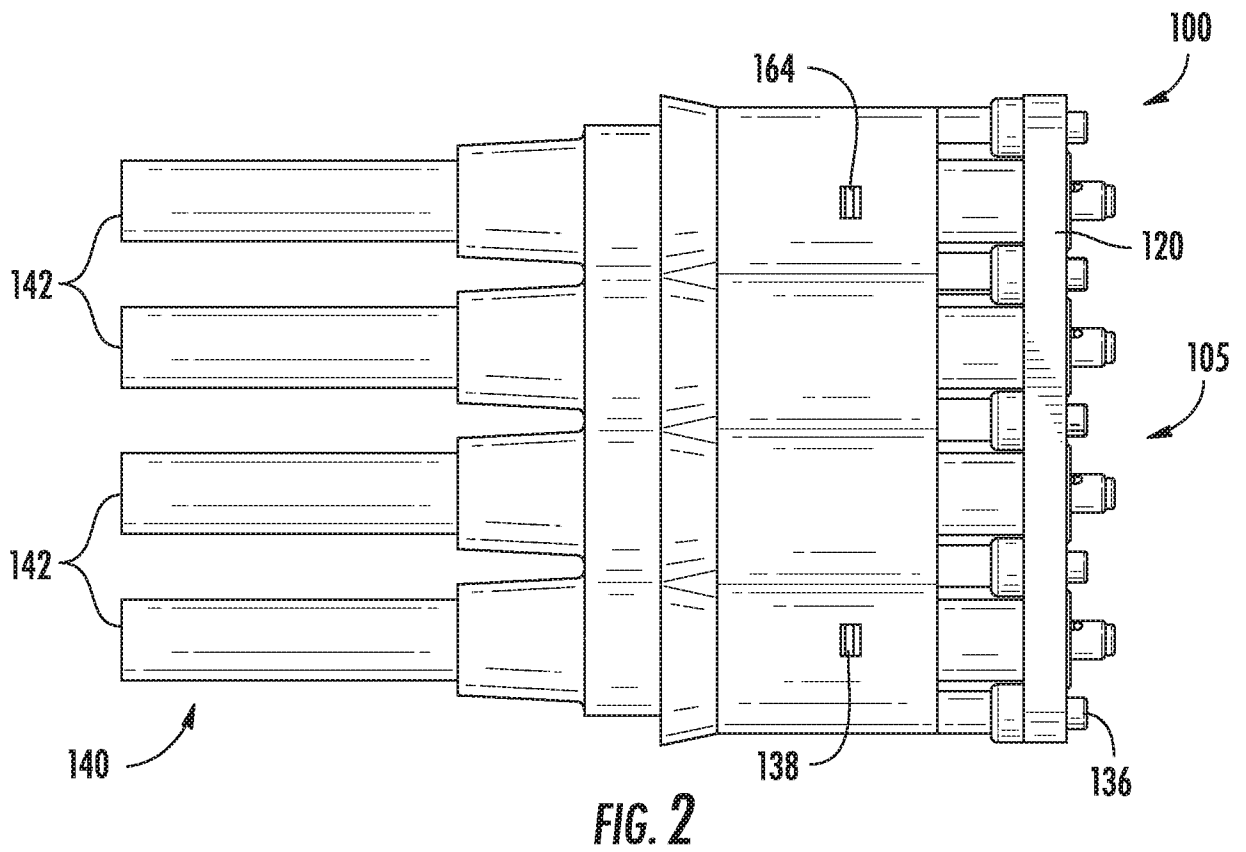
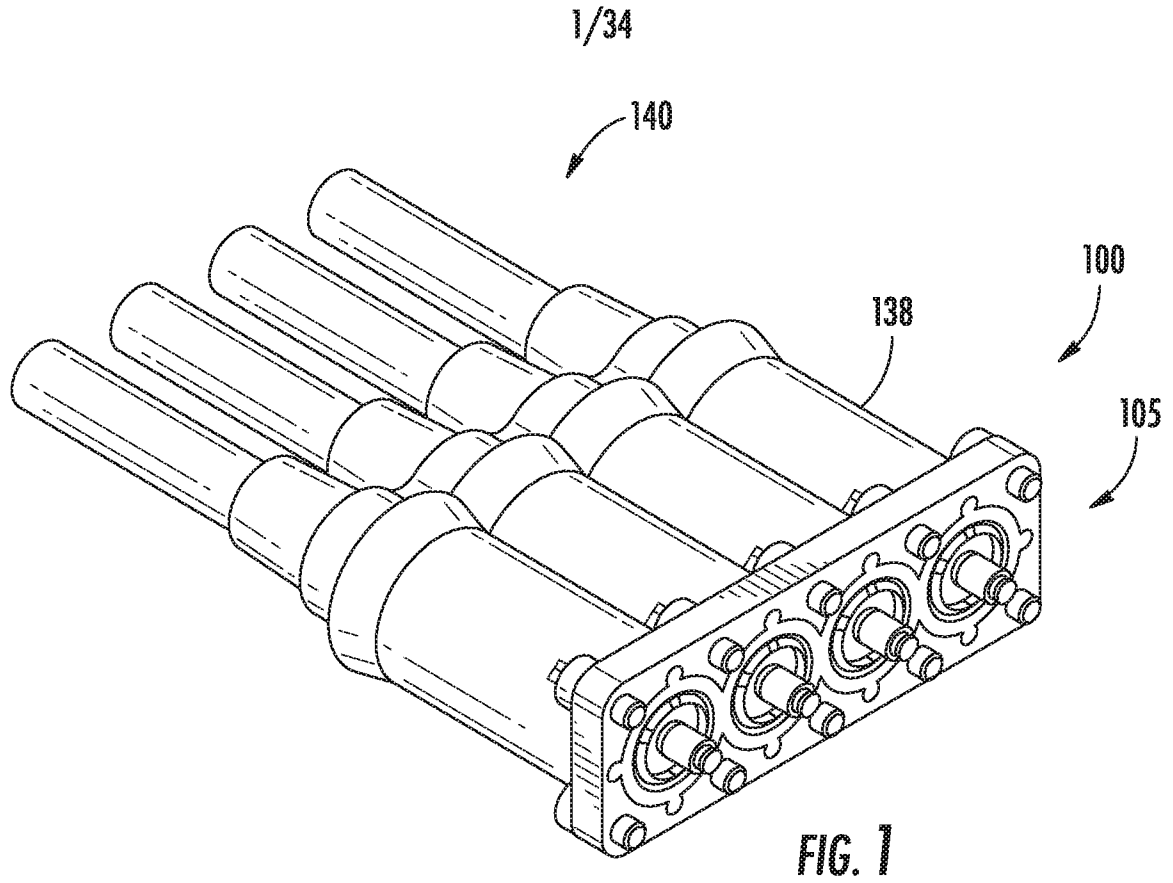

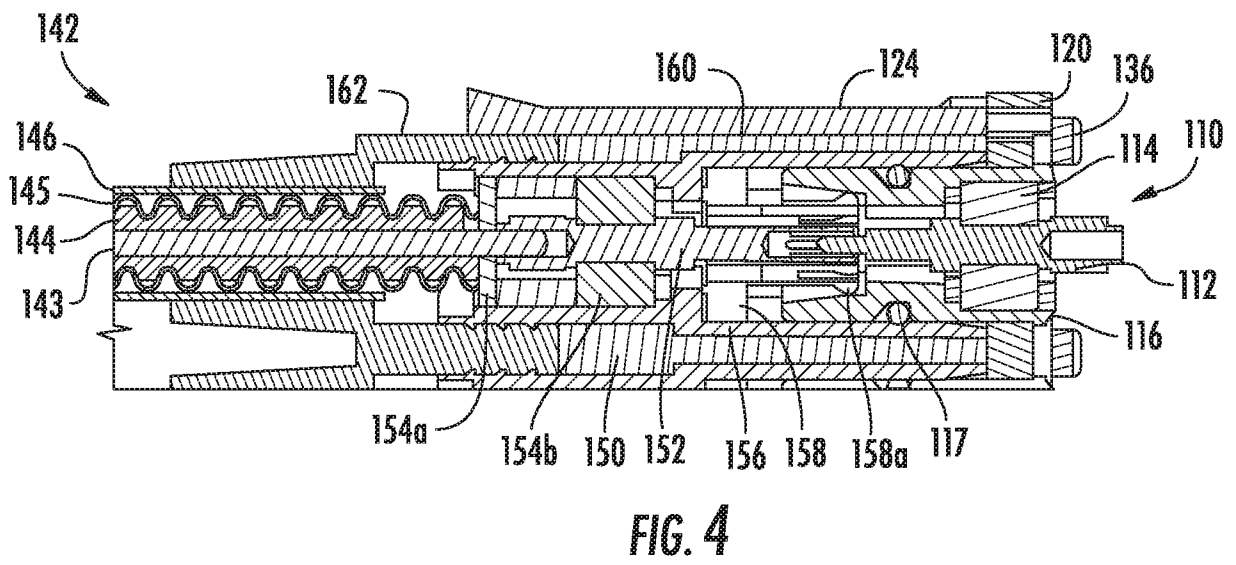
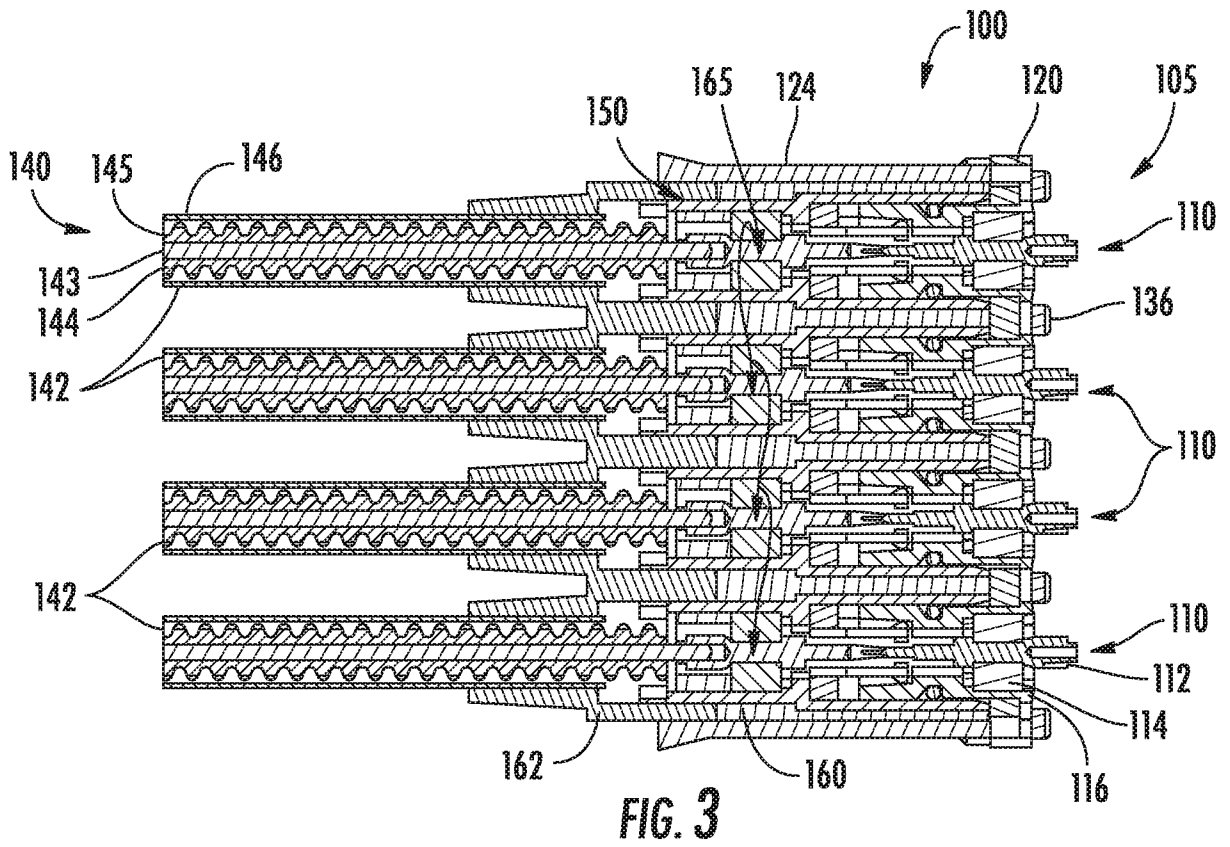

3/34

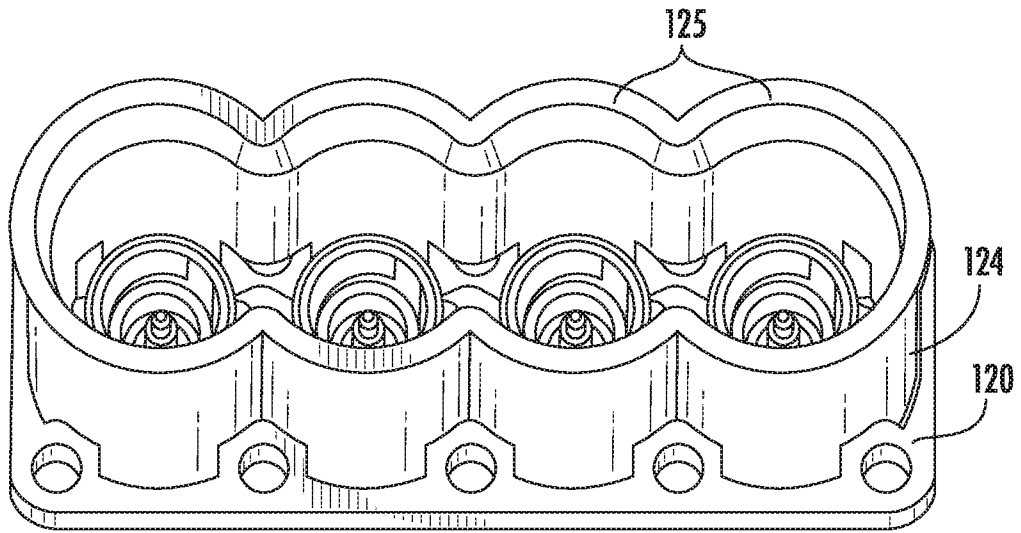

FIG. 5

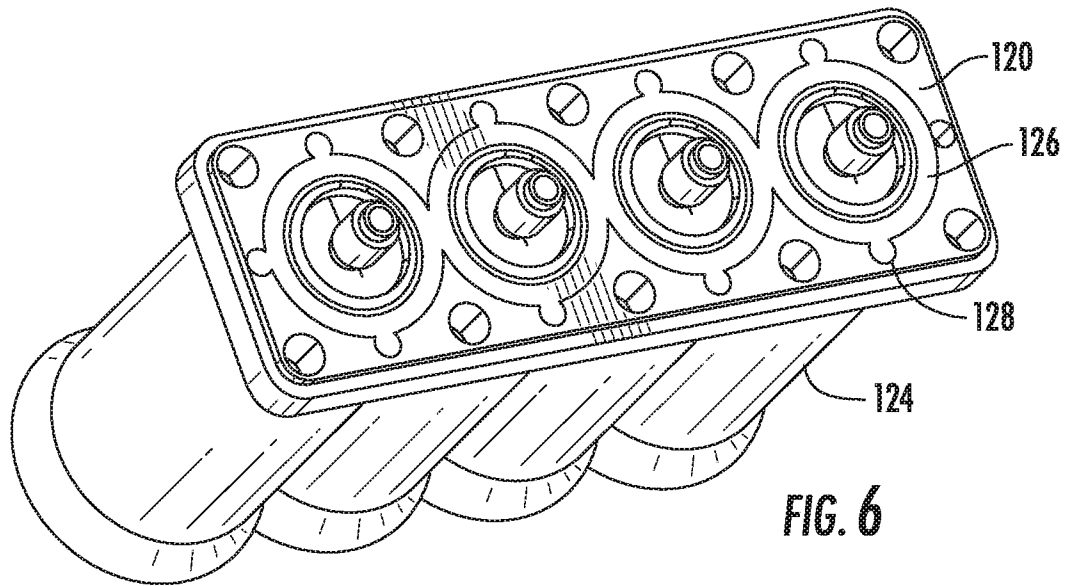

FIG. 6

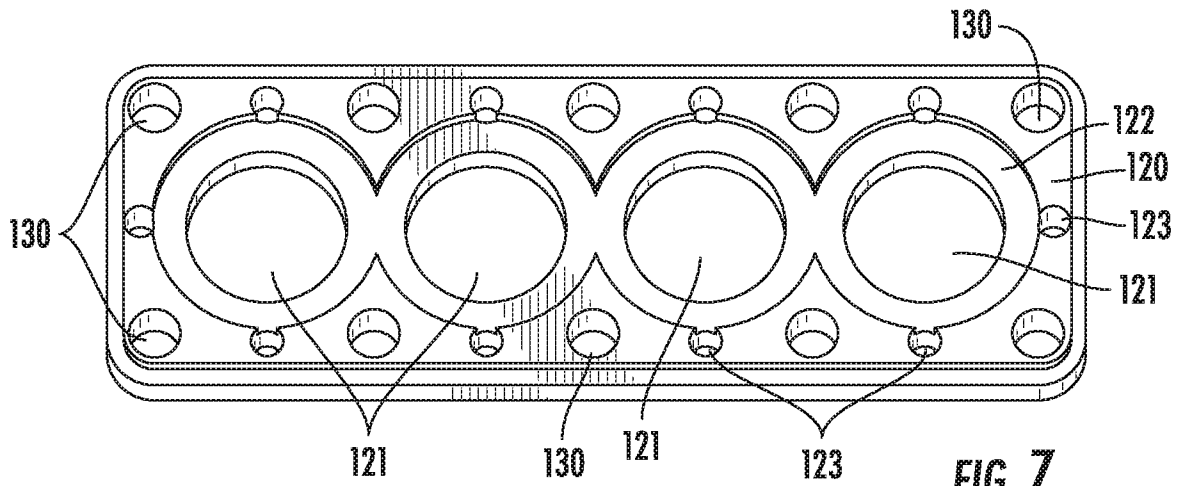
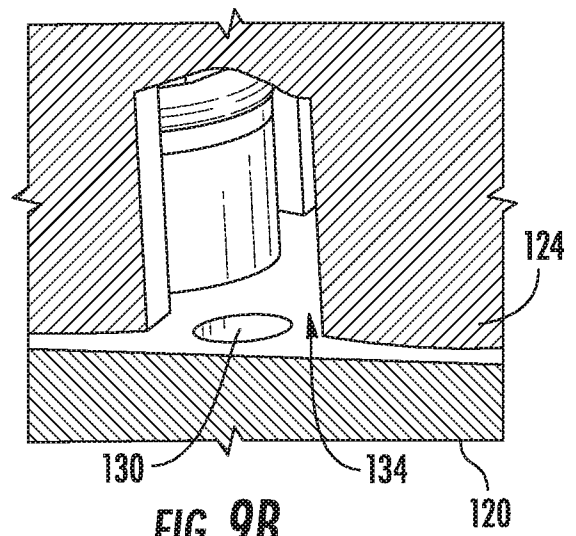
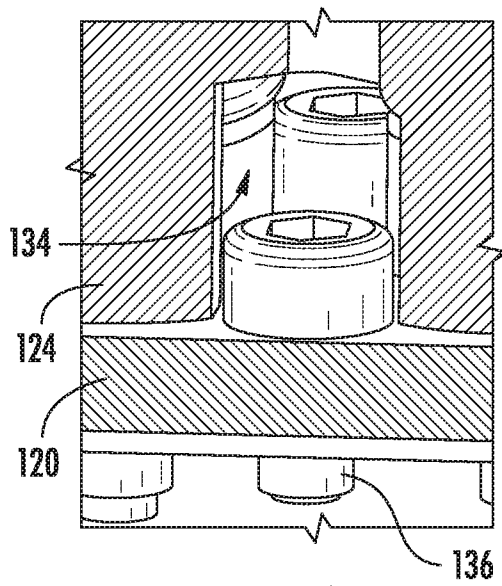
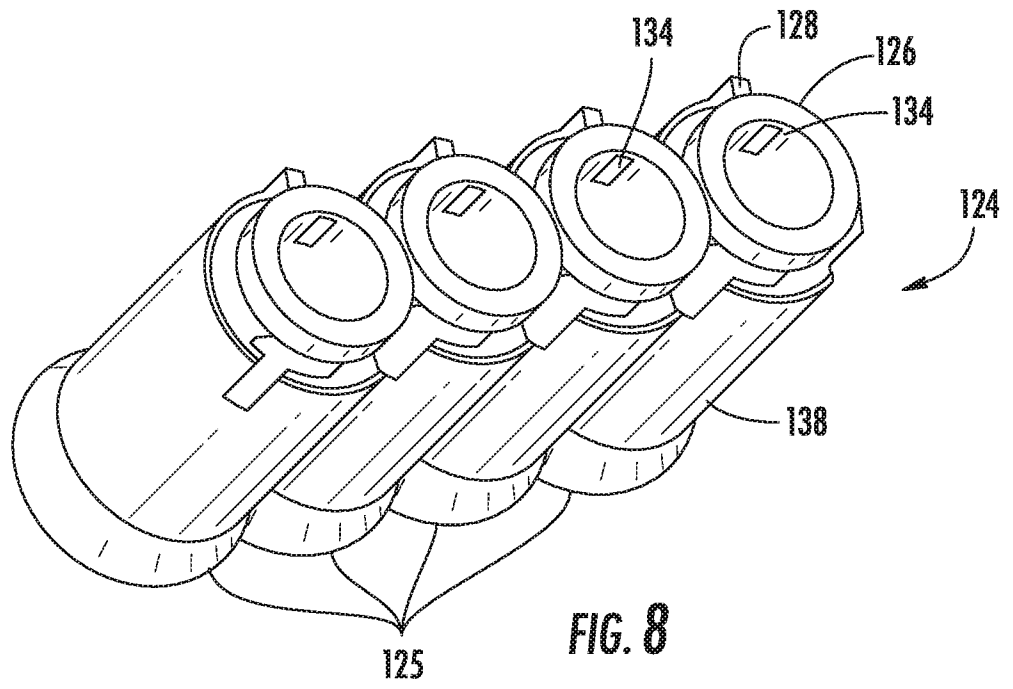
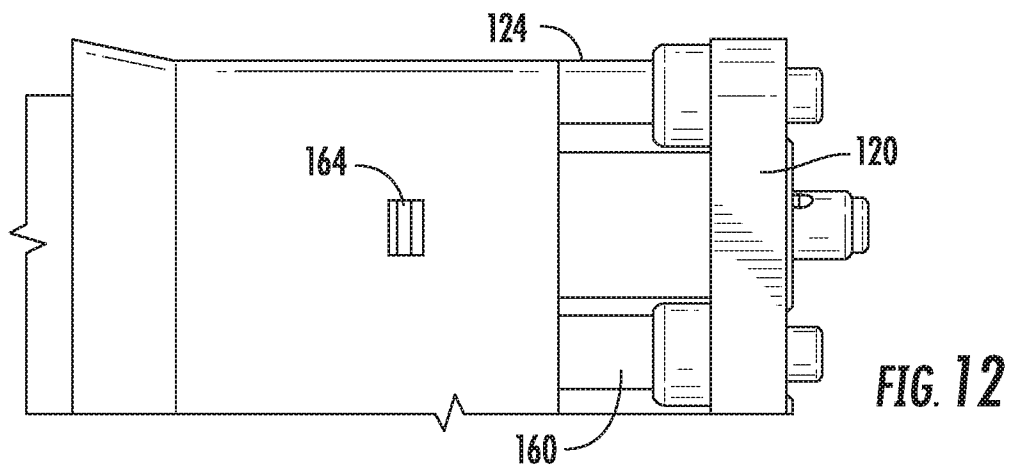
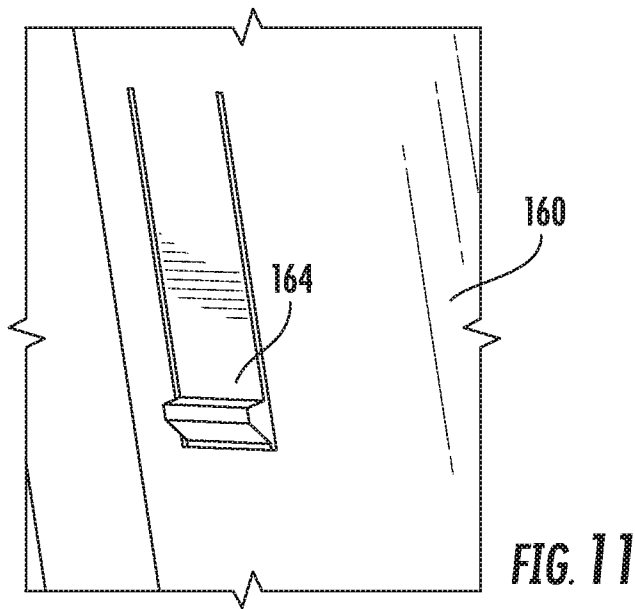
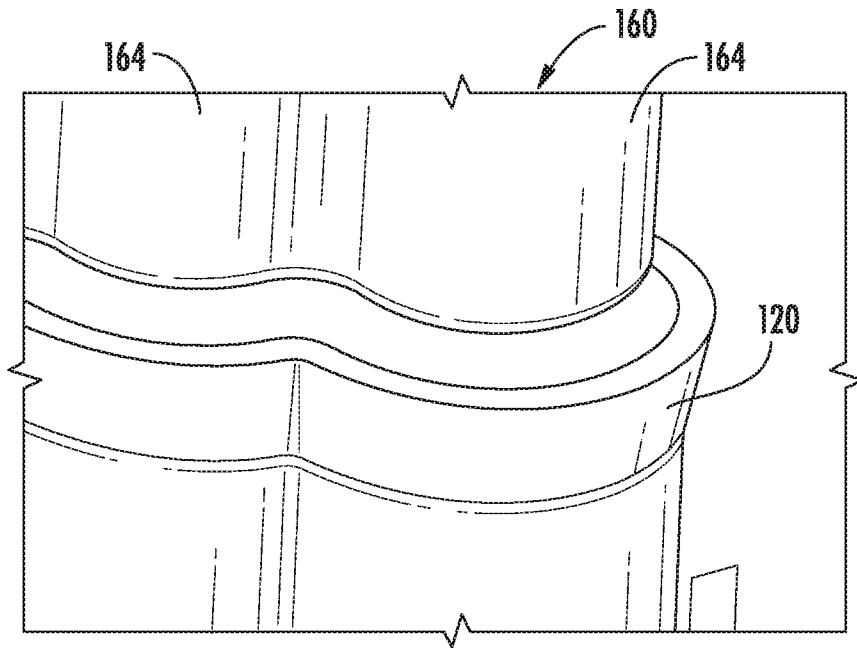
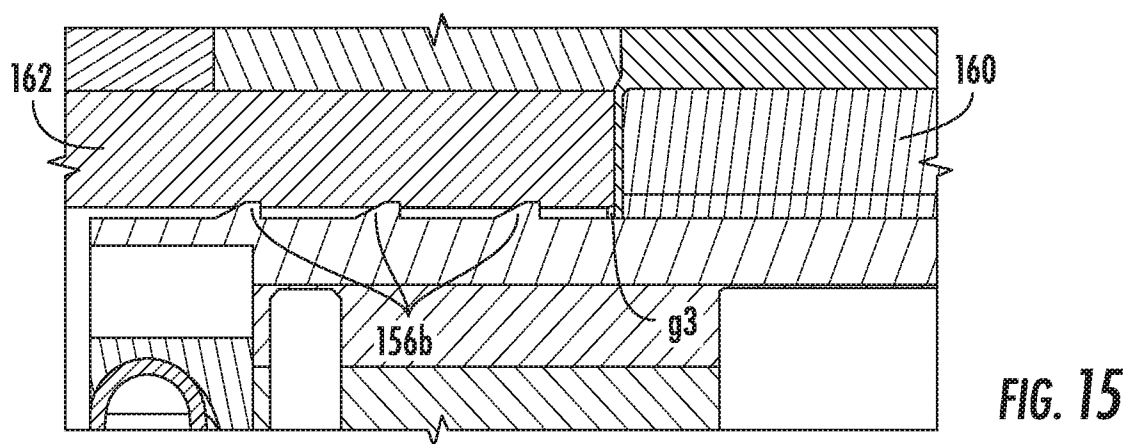
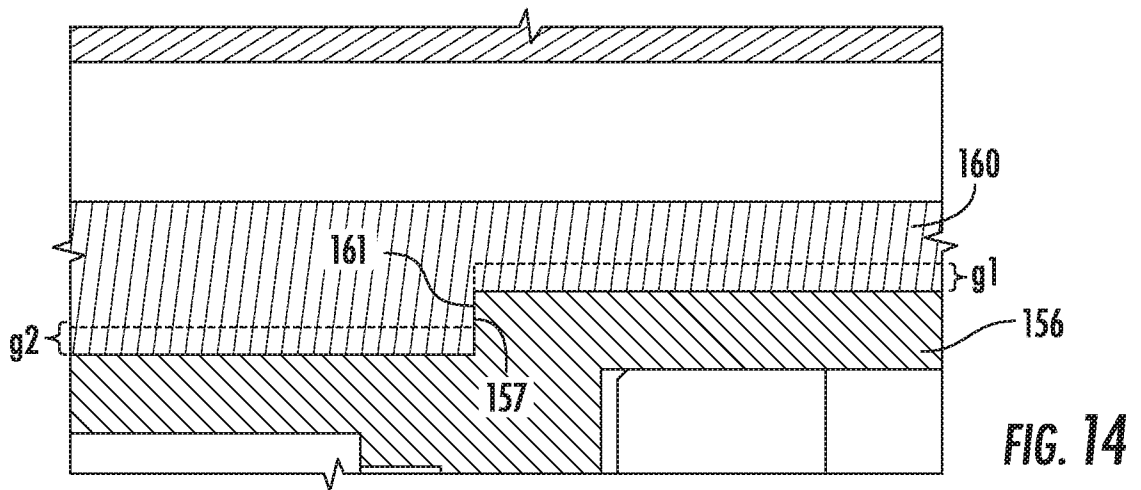
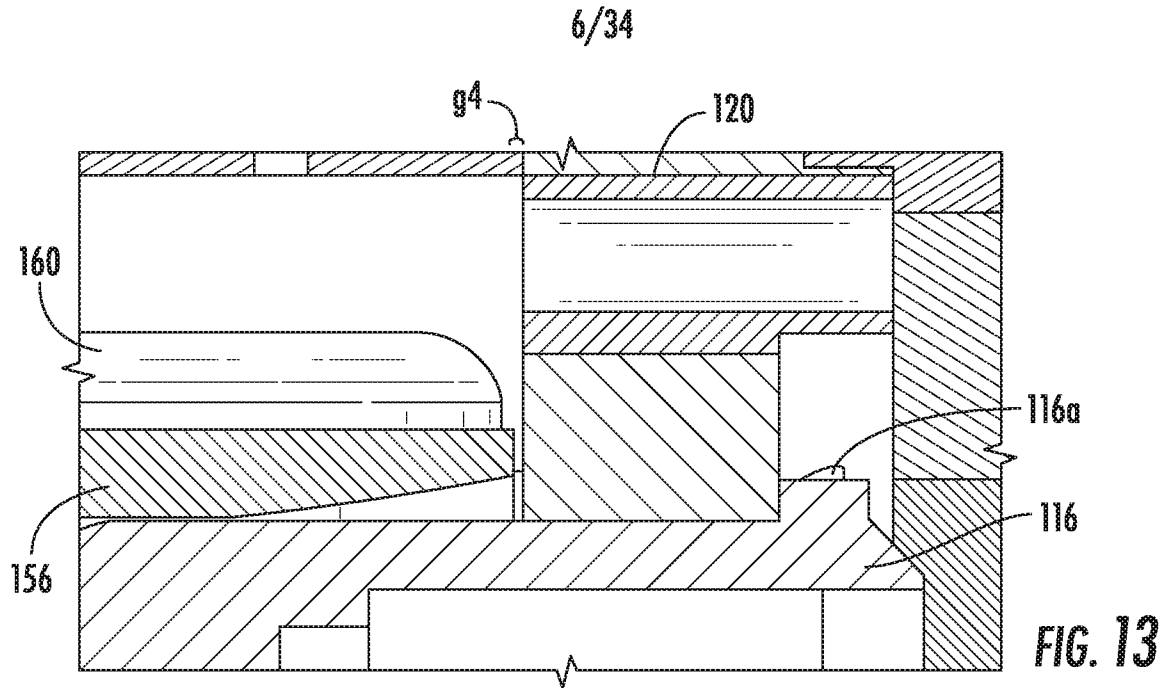

FIG. 7



5/34





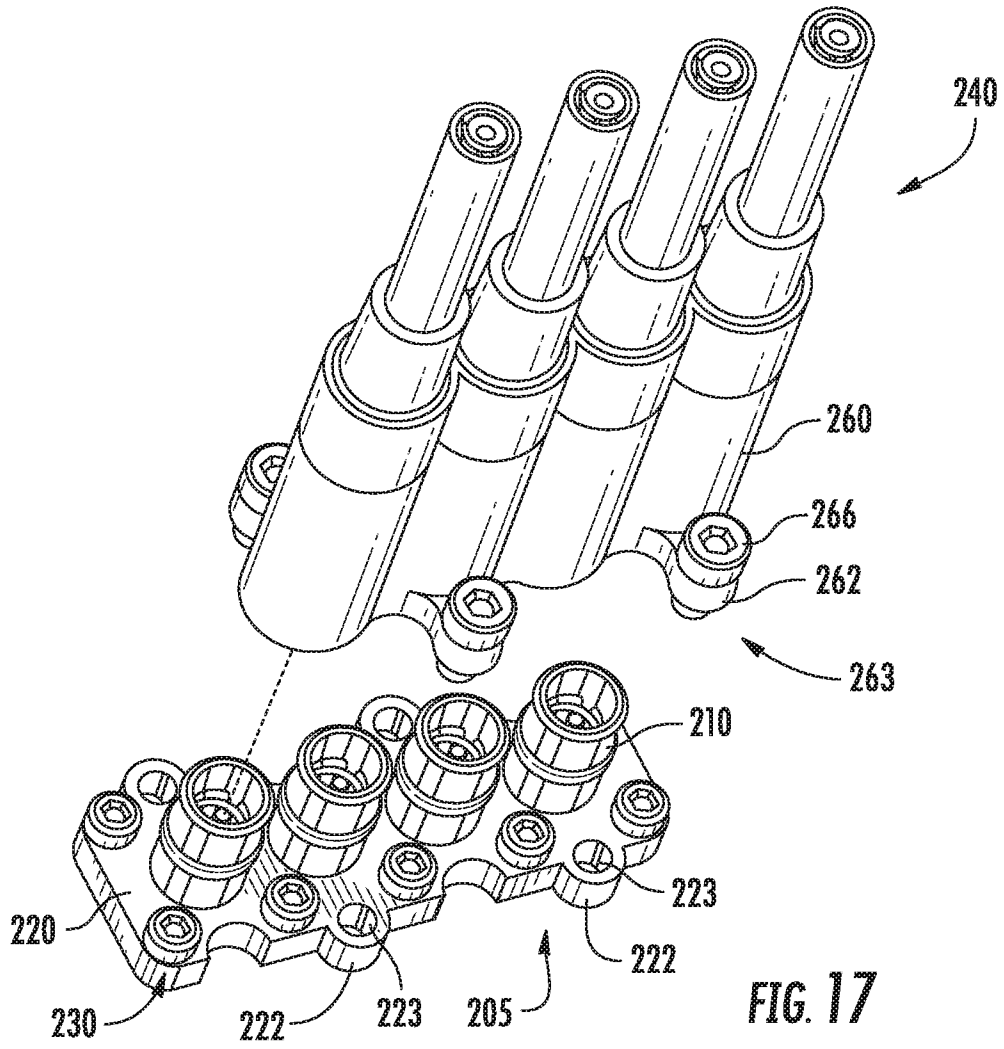
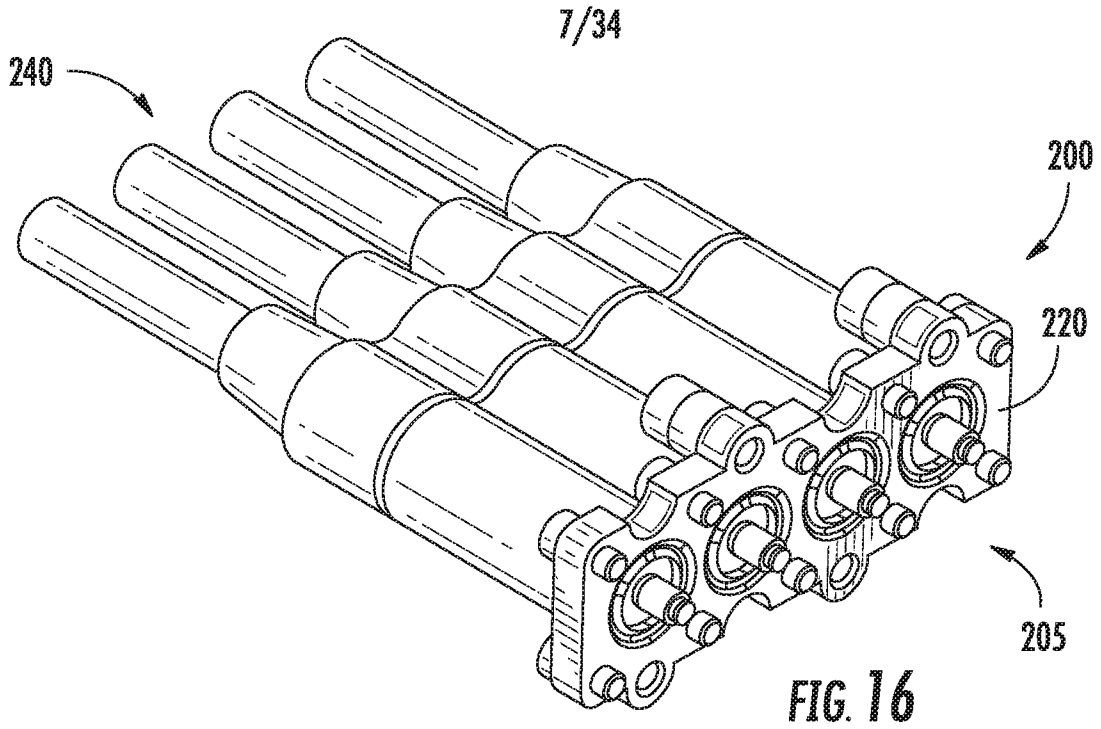

9/34

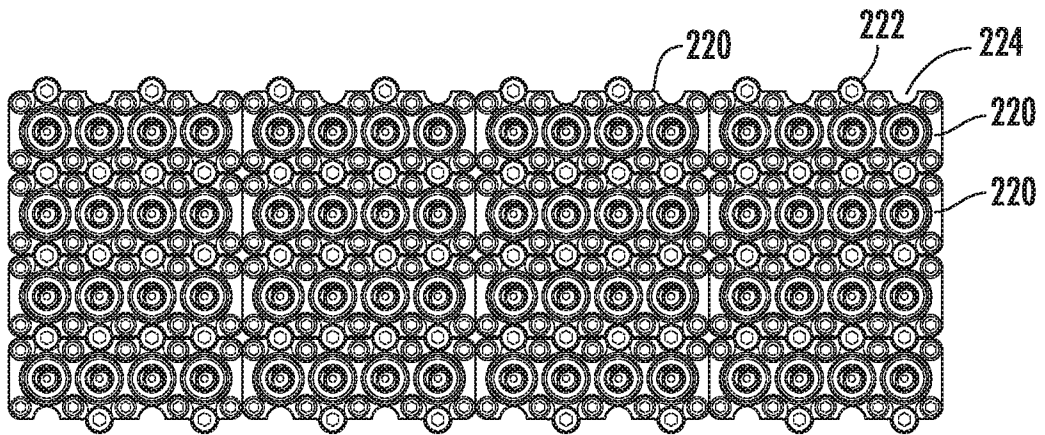

FIG. 21

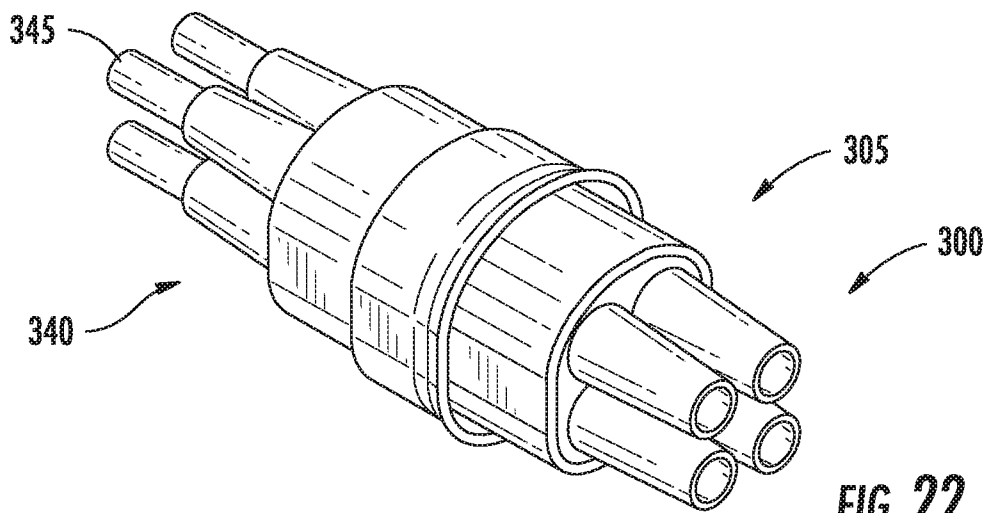

FIG. 22

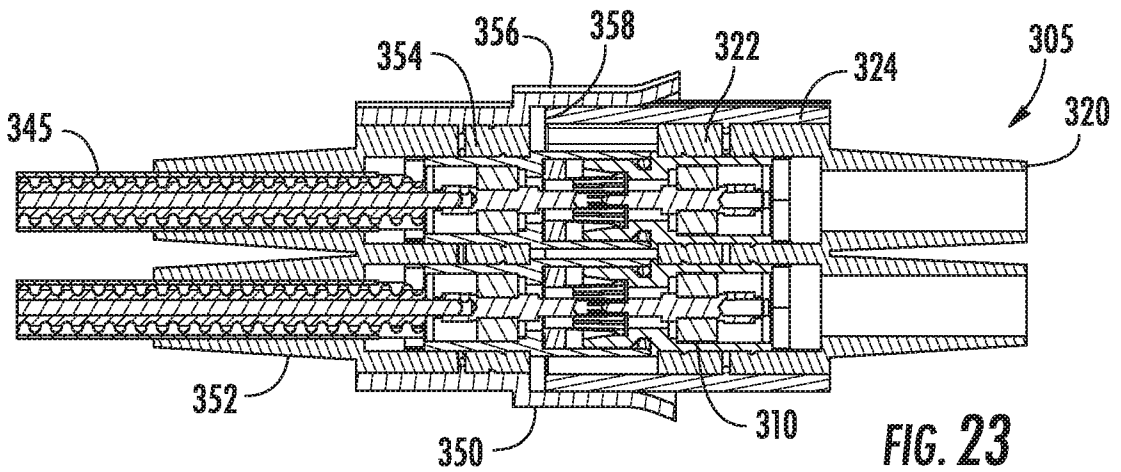

FIG. 23

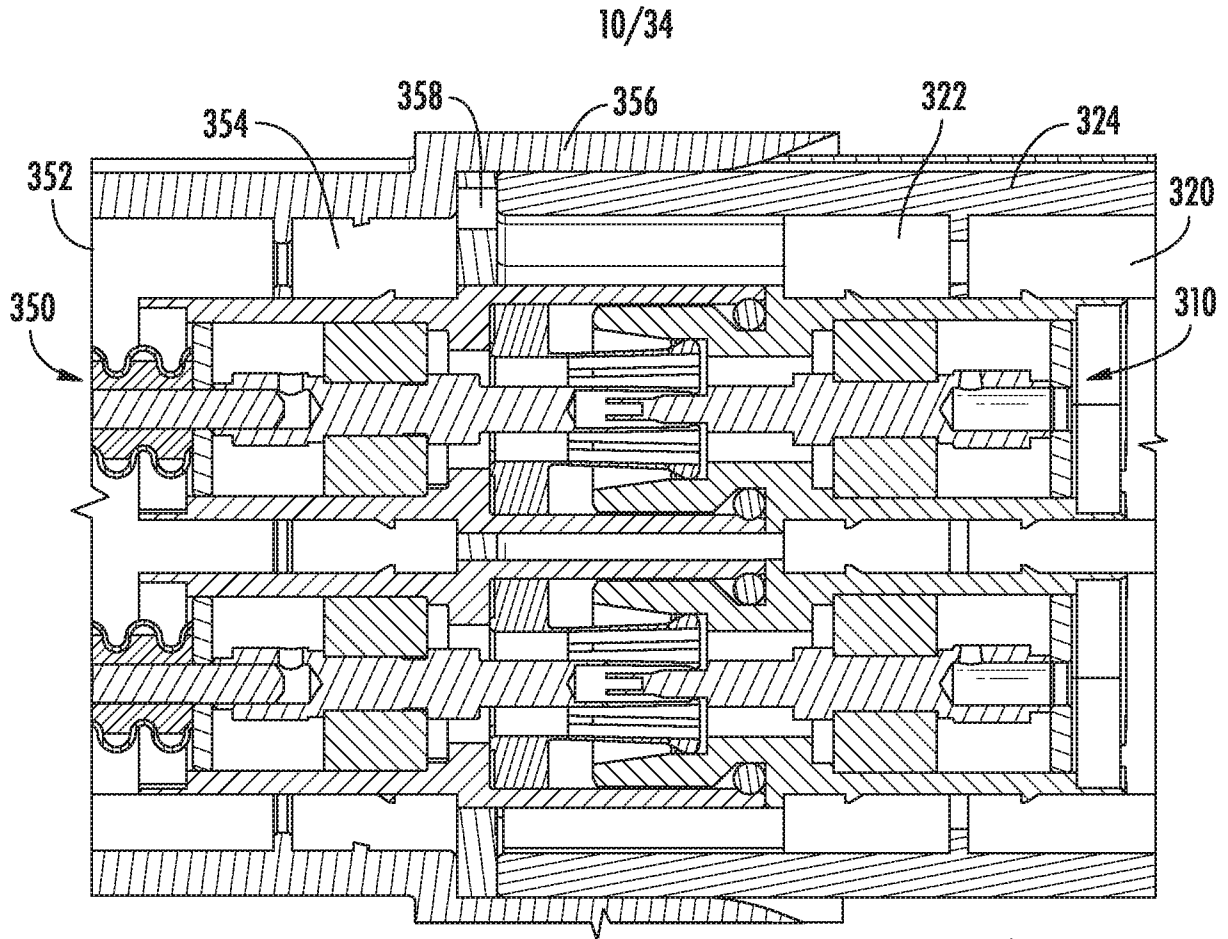

FIG. 24

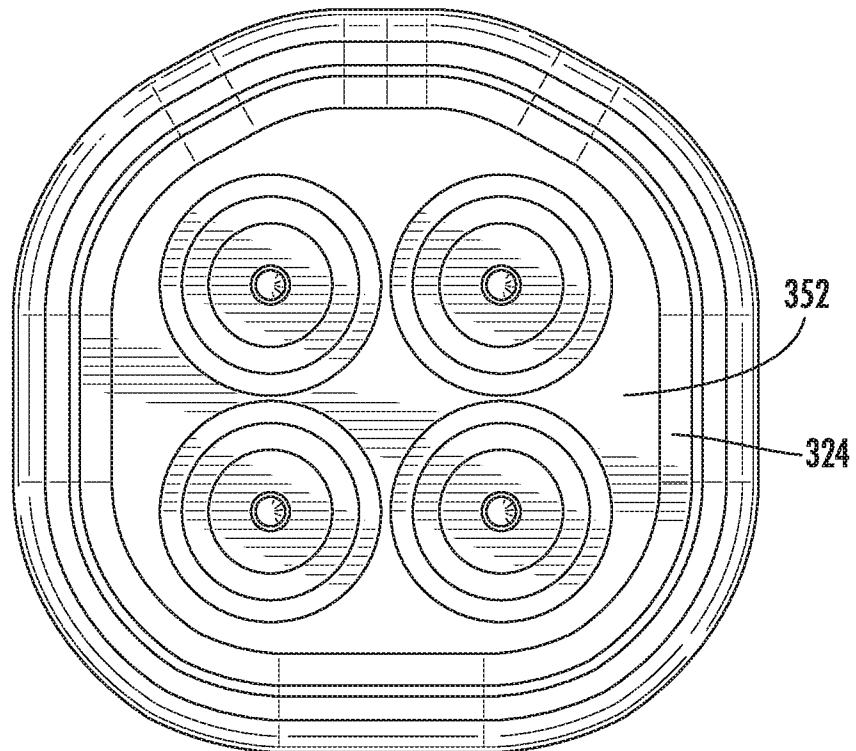

FIG. 25

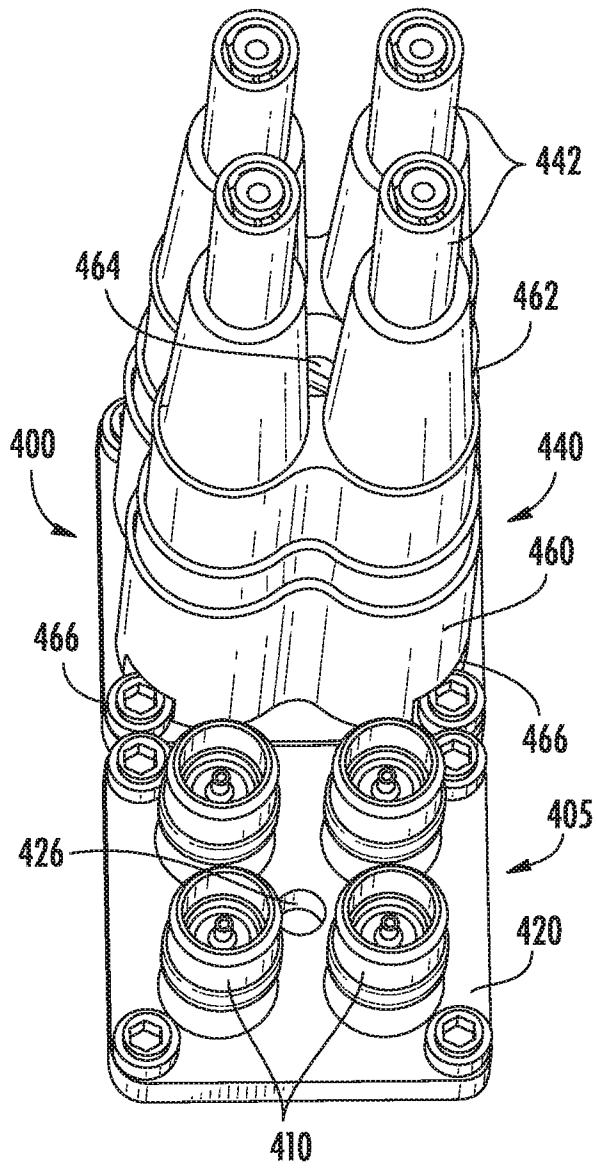

FIG. 26

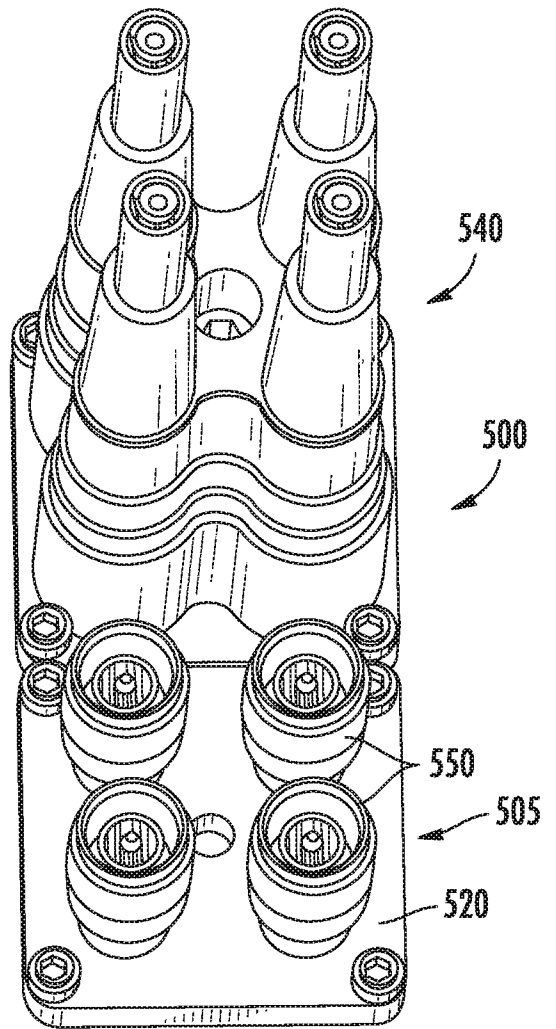
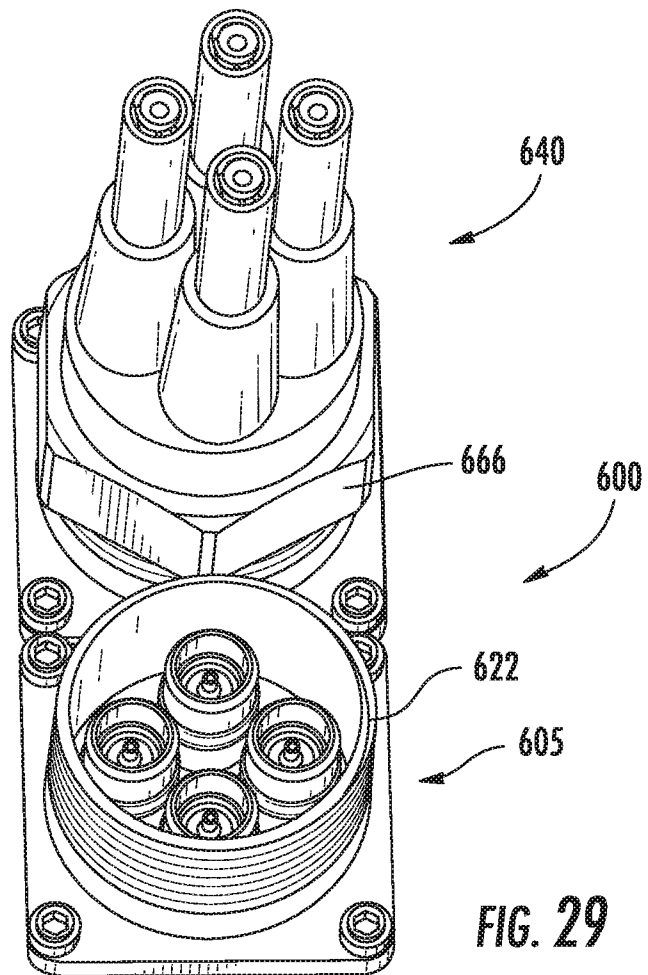
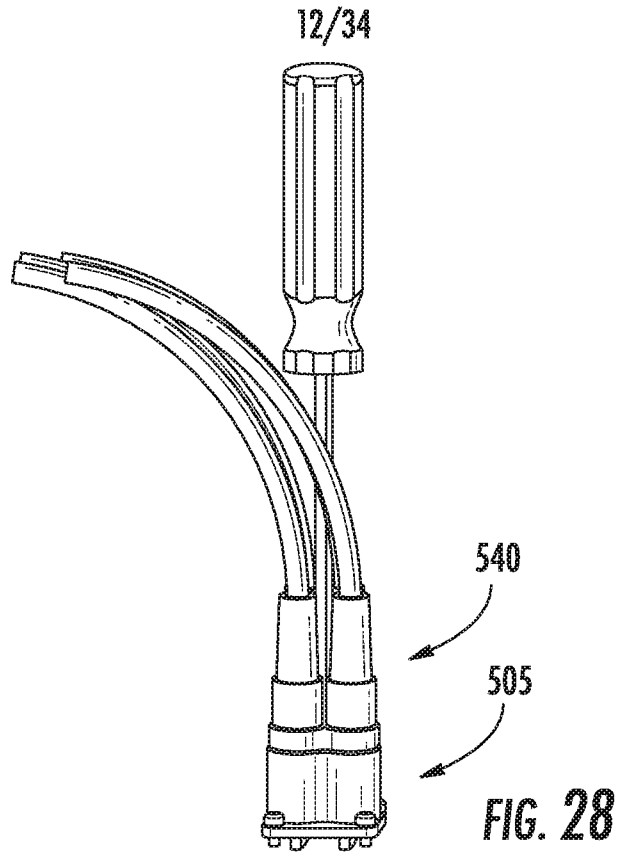
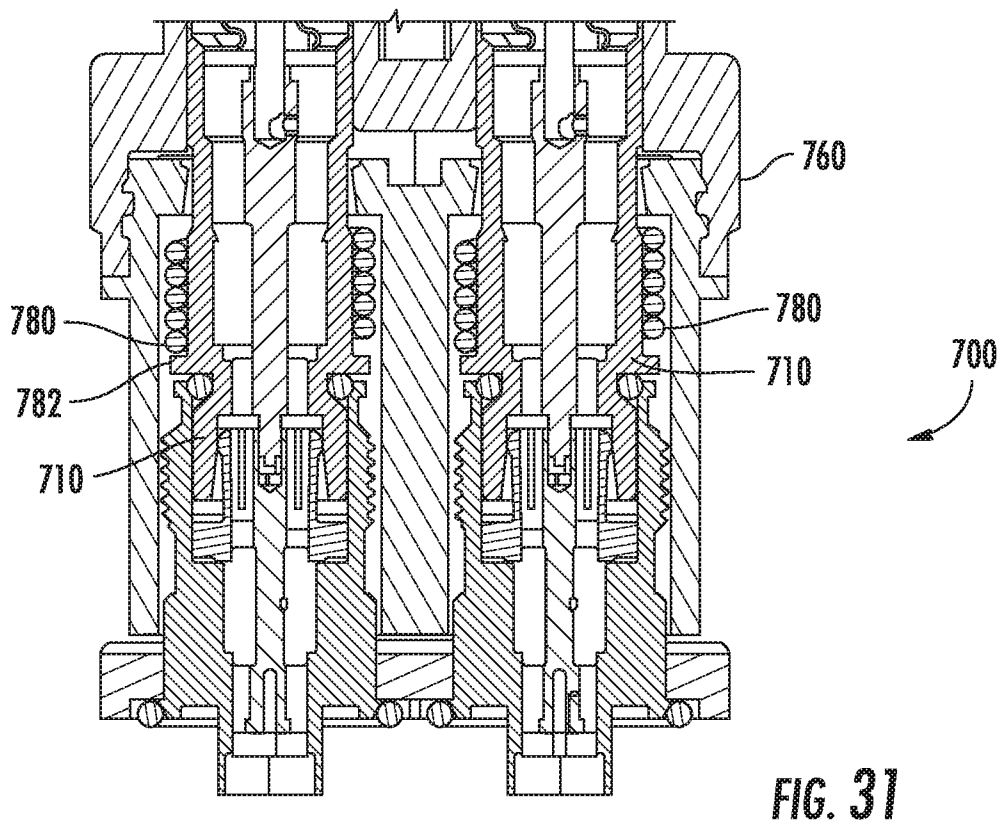
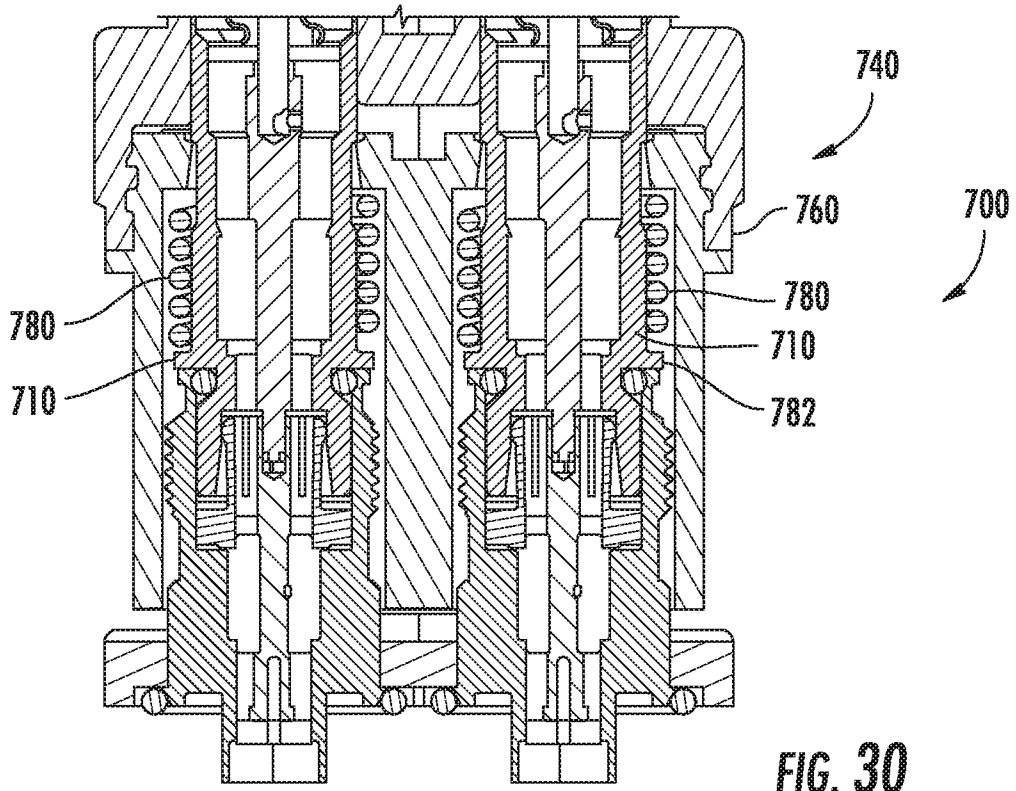

FIG. 27





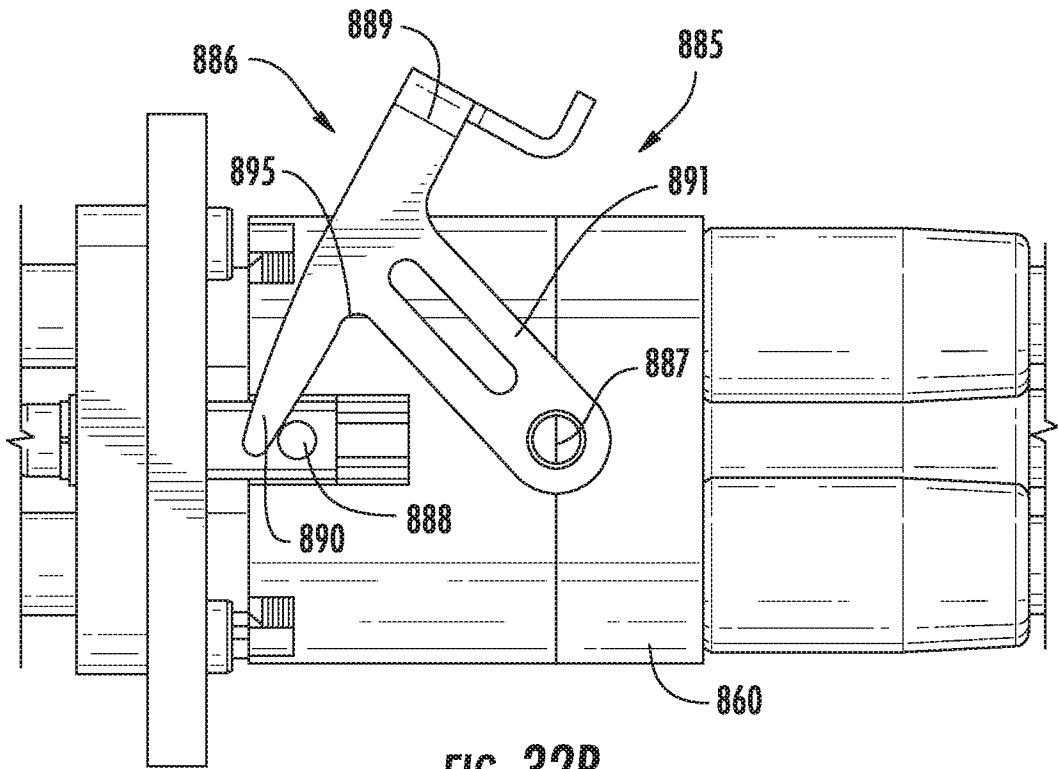

FIG. 32B

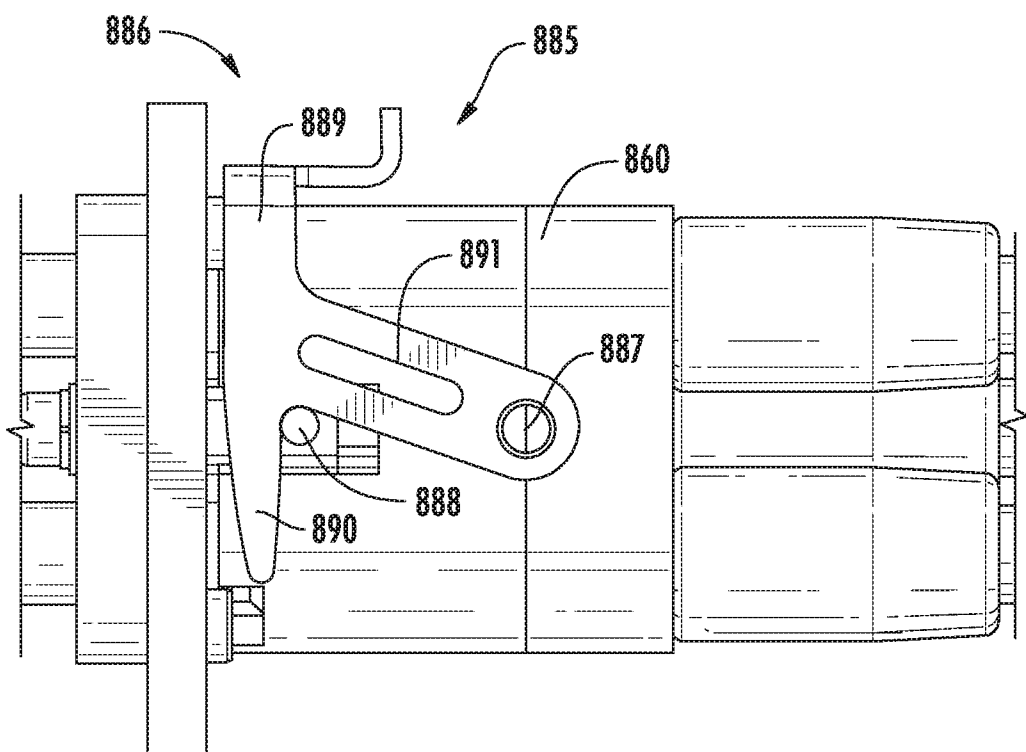

FIG. 32C

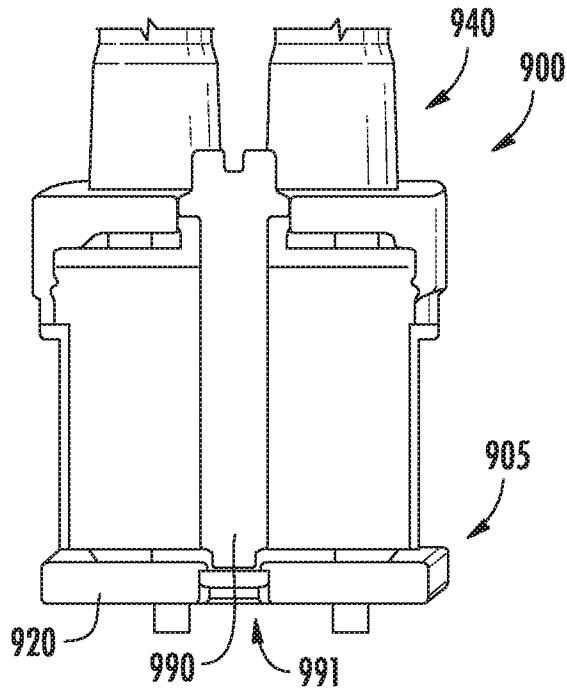

FIG. 33

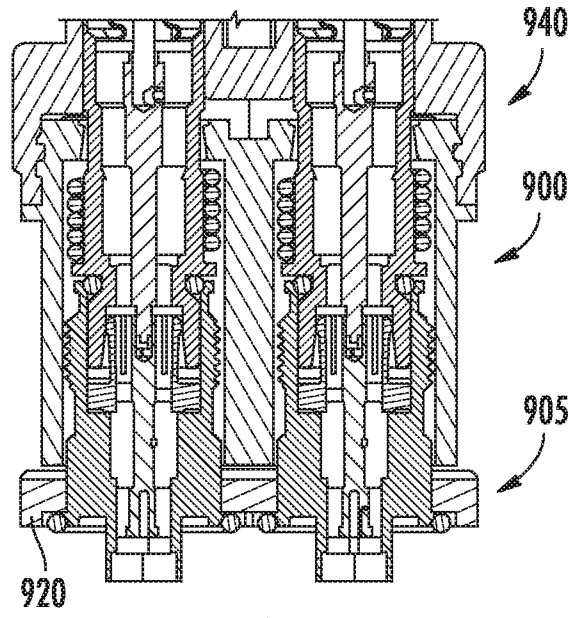

FIG. 34

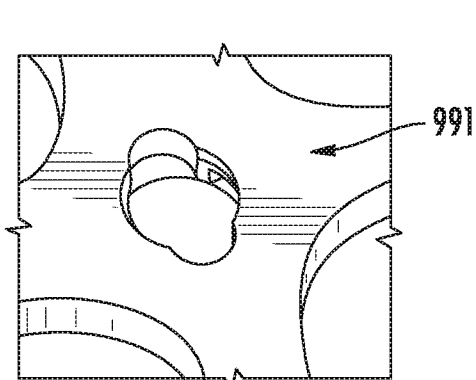

FIG. 35

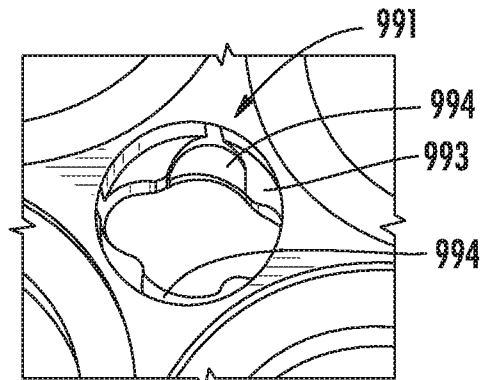

FIG. 36

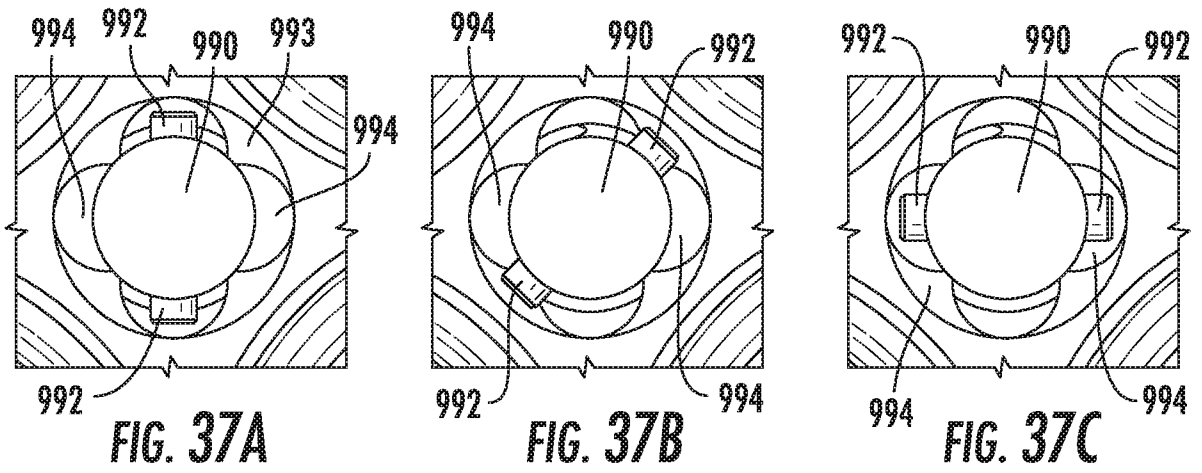

FIG. 37A

FIG. 37B

FIG. 37C

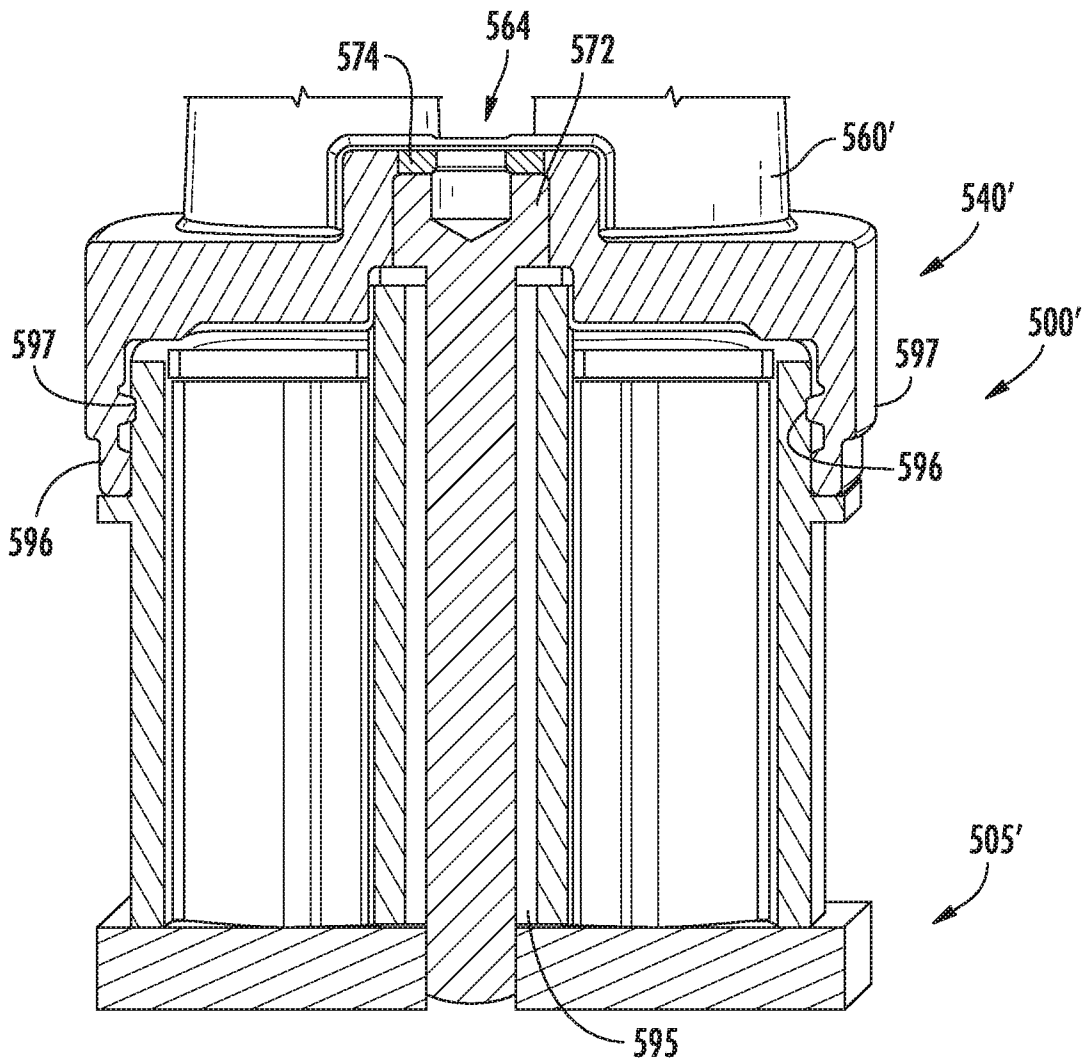

FIG. 38

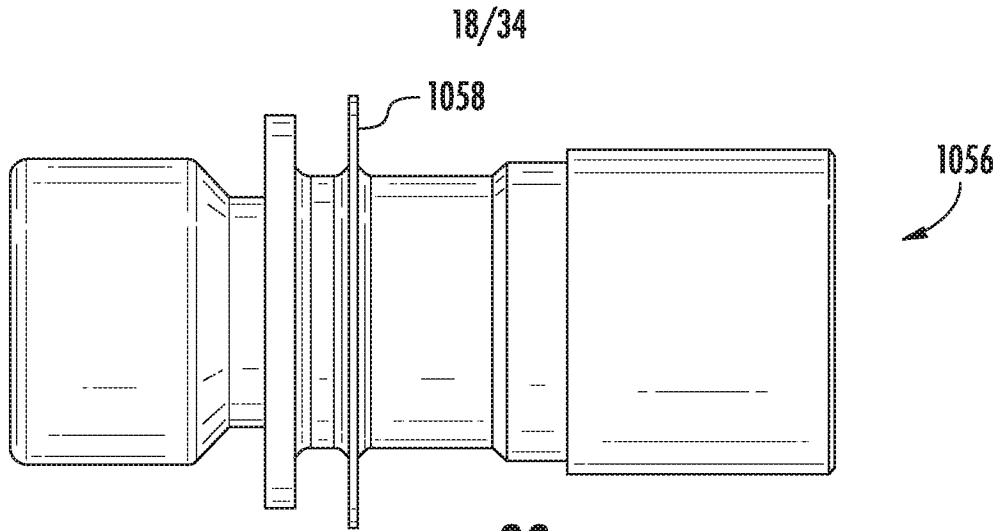

FIG. 39

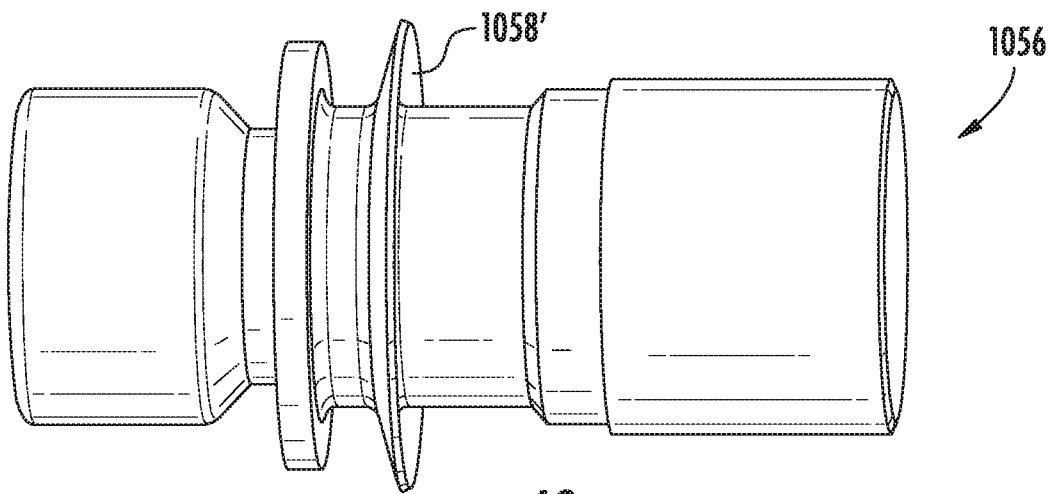

FIG. 40

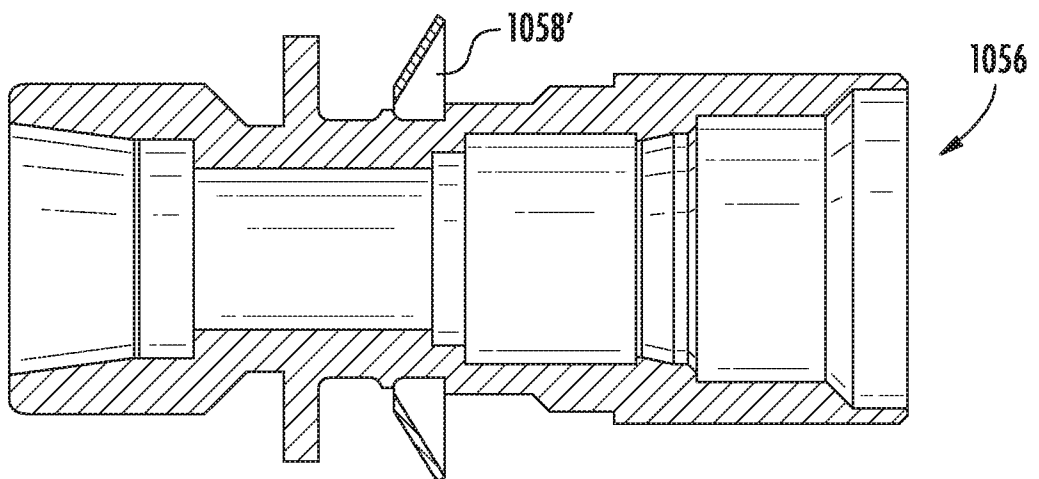

FIG. 41

19/34

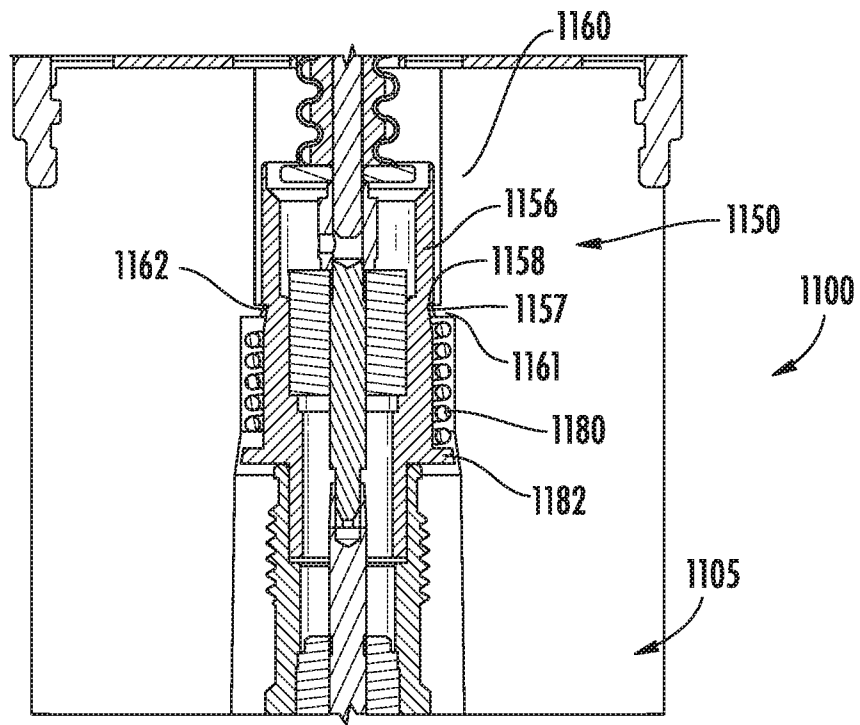

FIG. 42

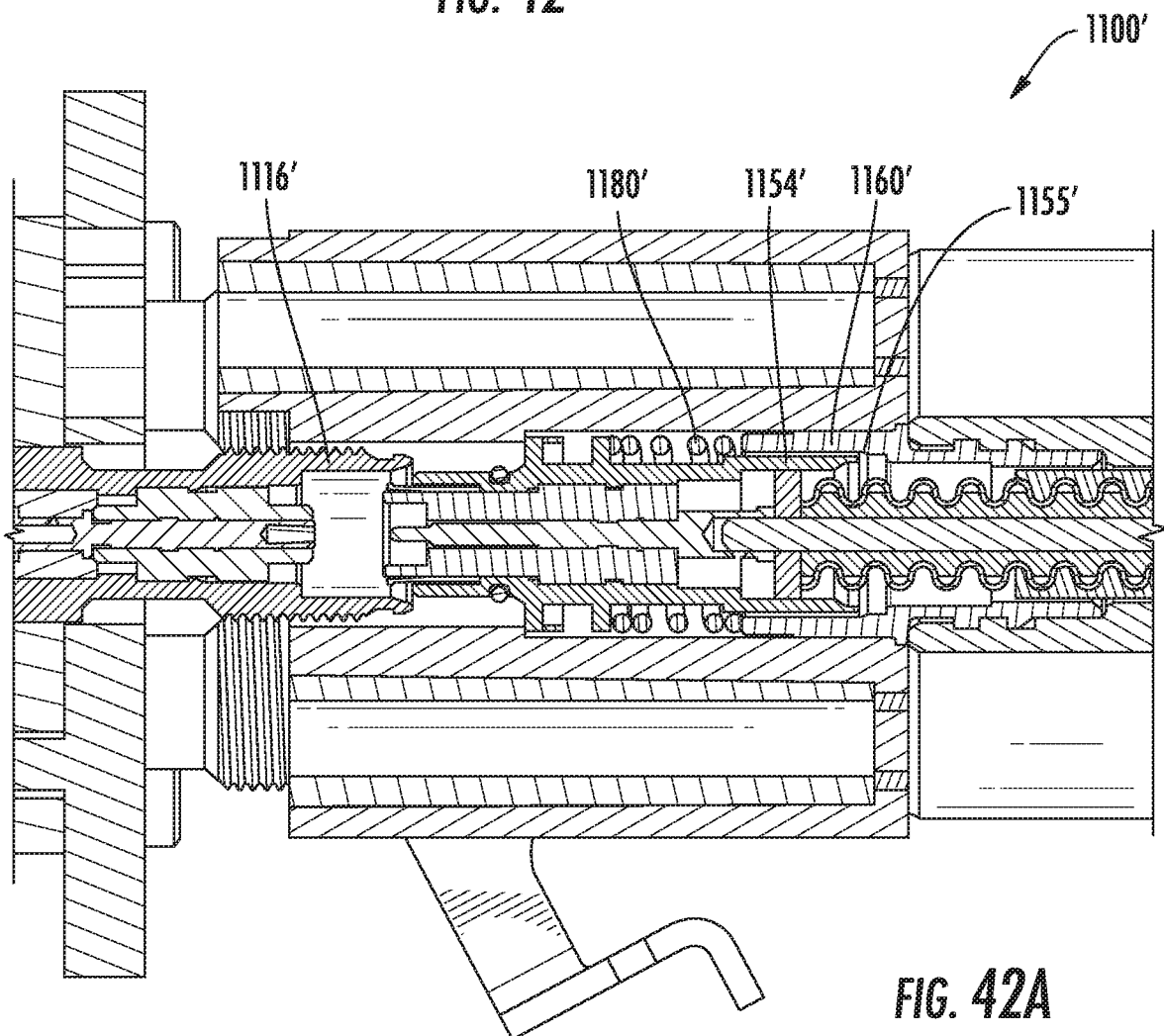

FIG. 42A

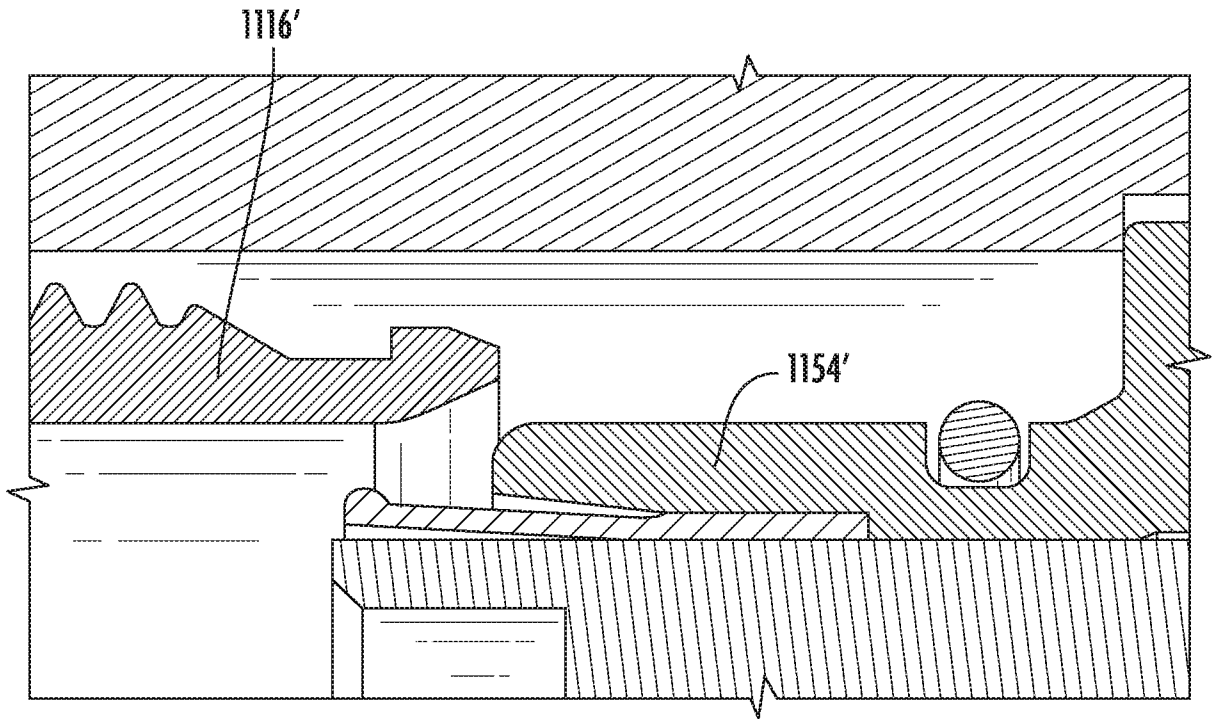

FIG. 42B

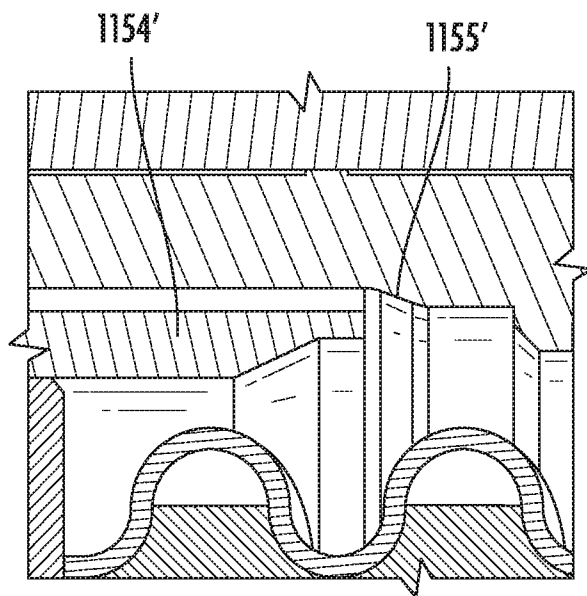

FIG. 42C

21/34

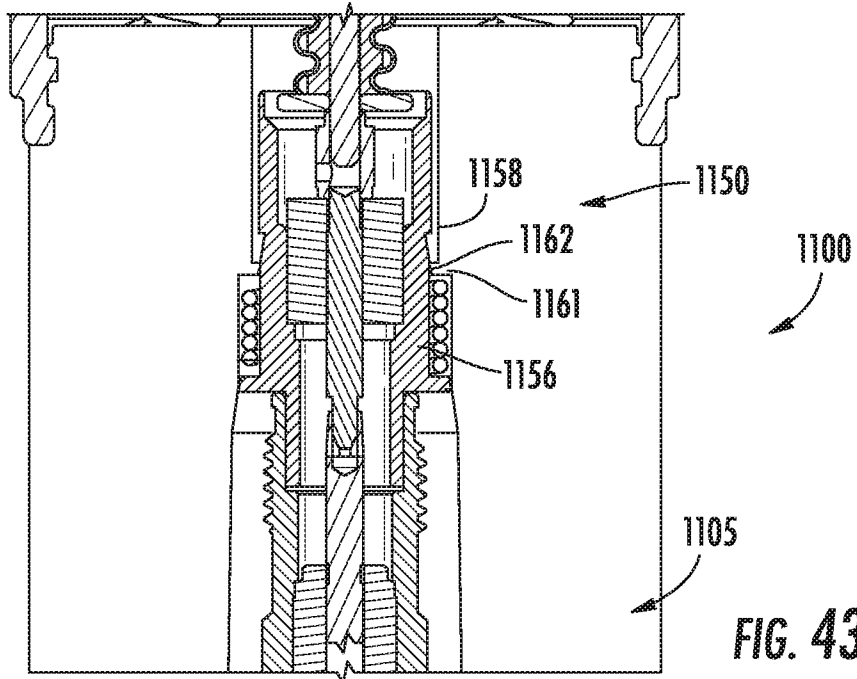

FIG. 43

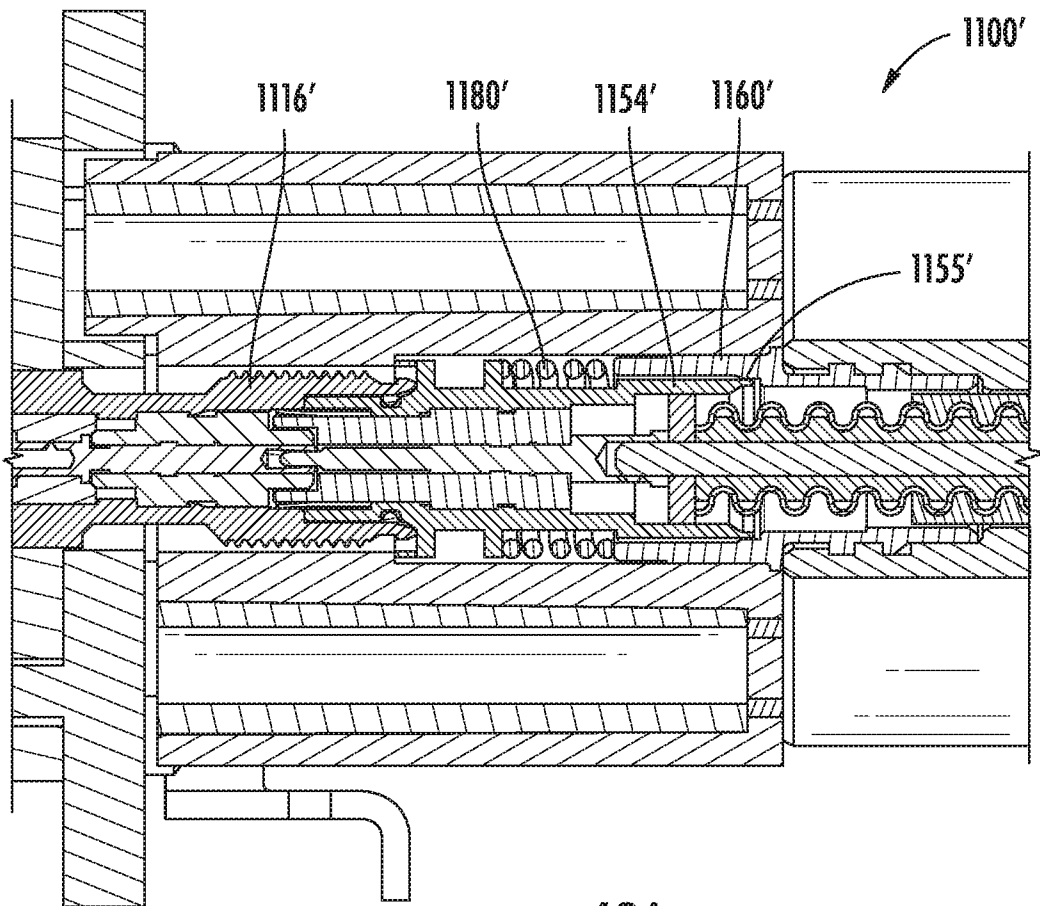

FIG. 43A

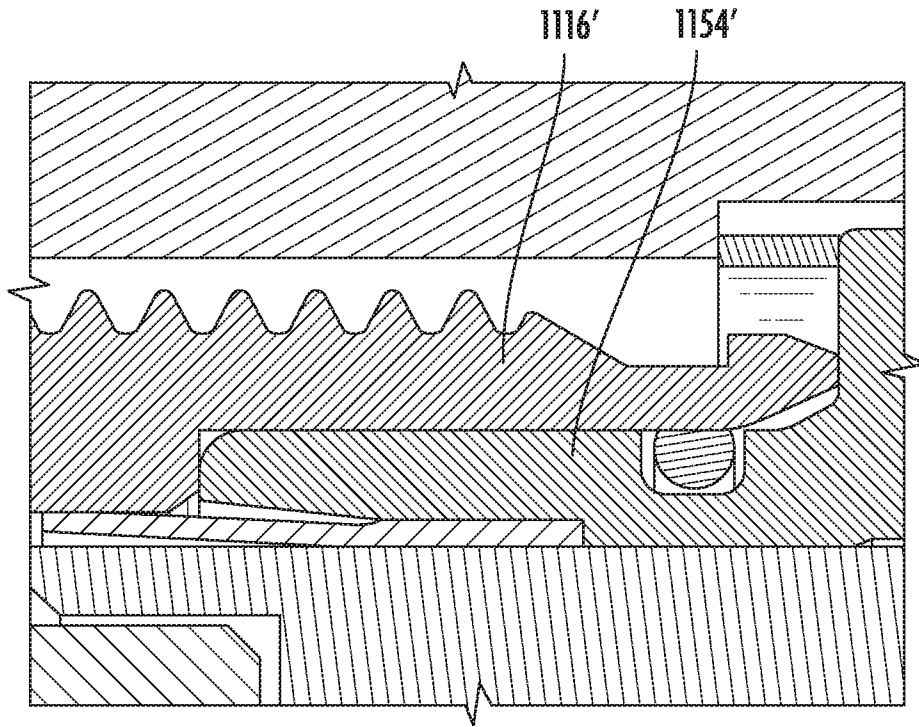

FIG. 43B

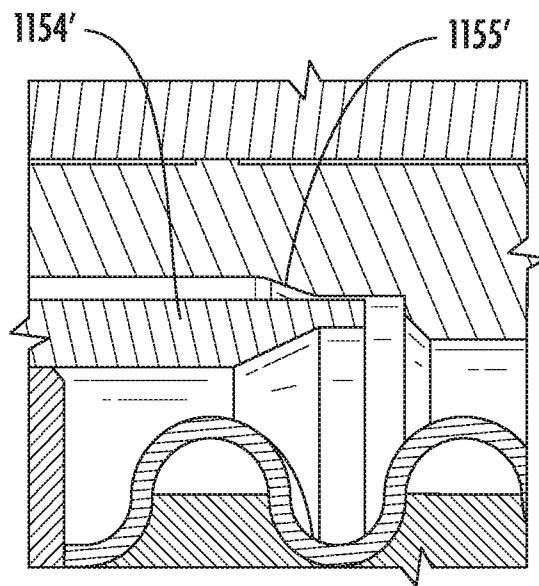

FIG. 43C

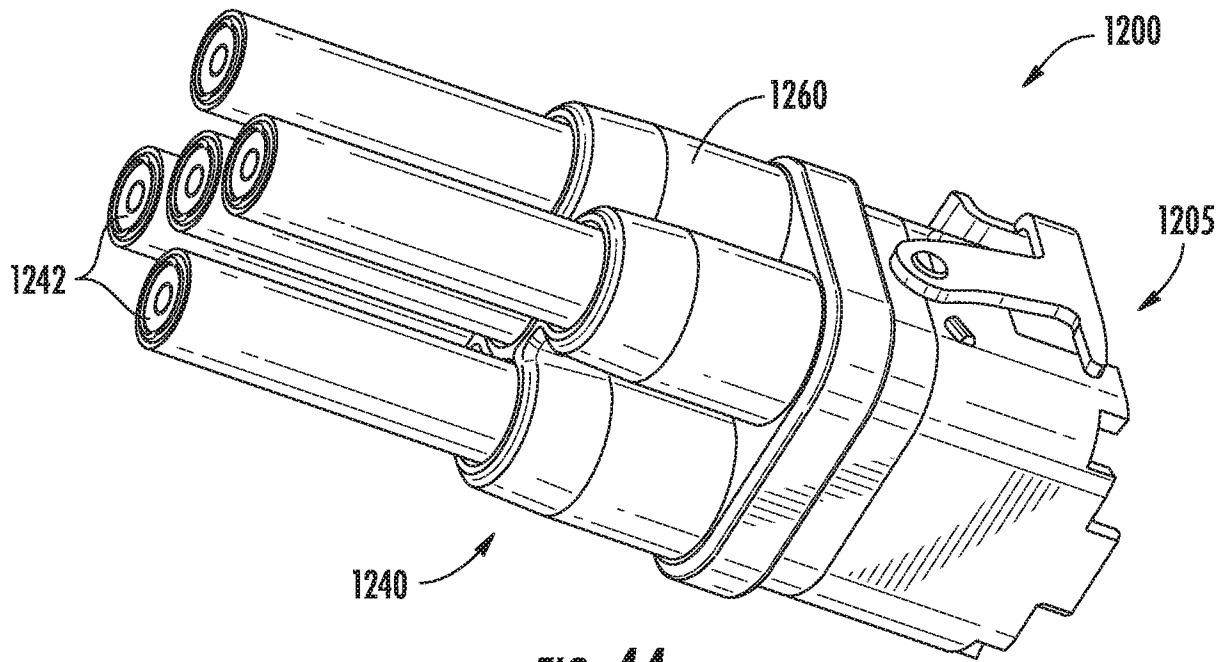

FIG. 44

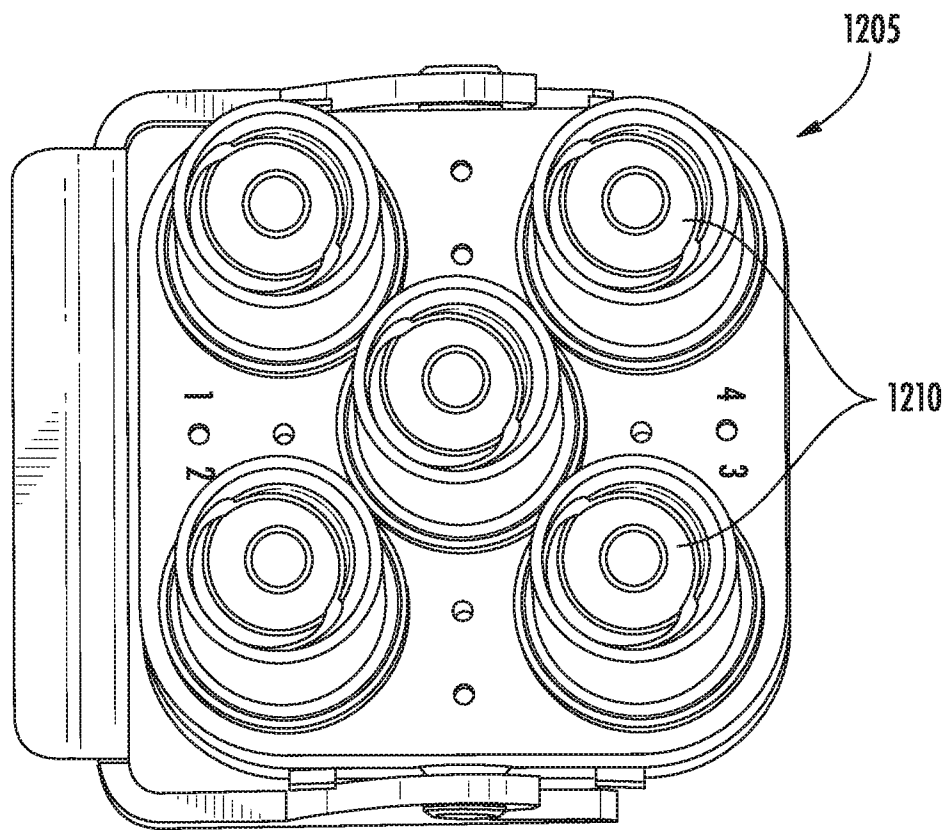
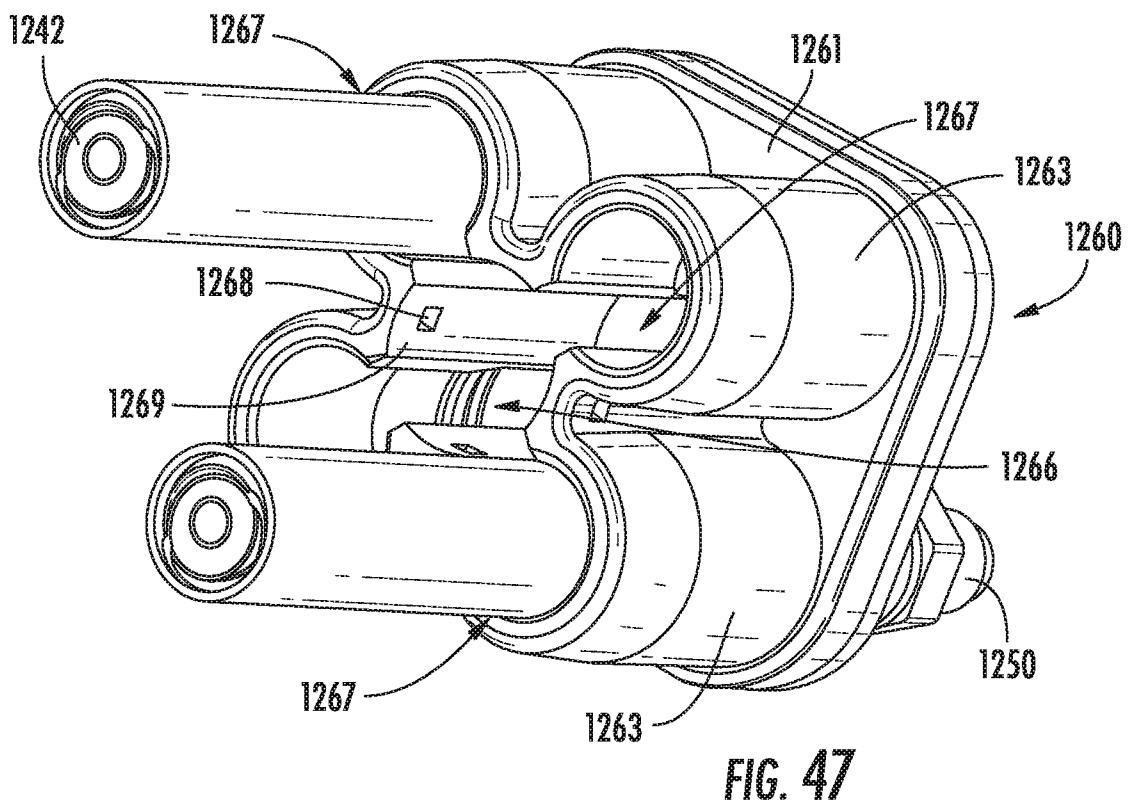
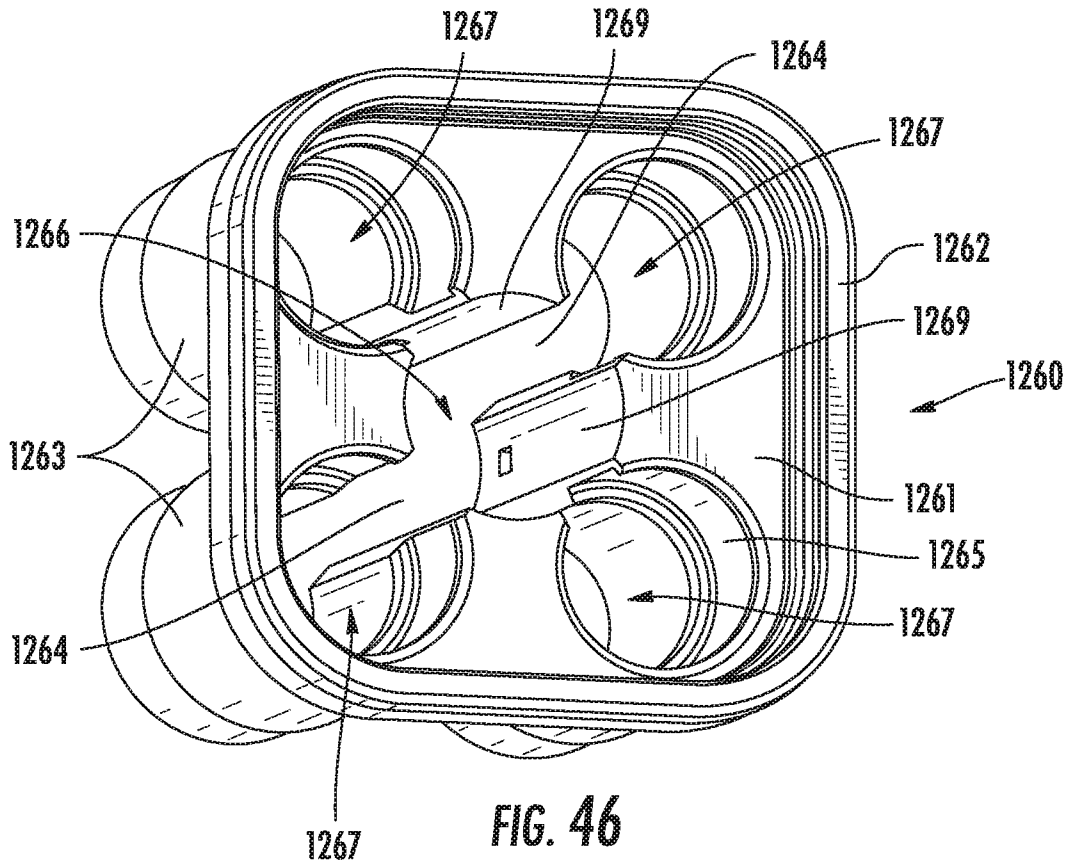

FIG. 45



25/34

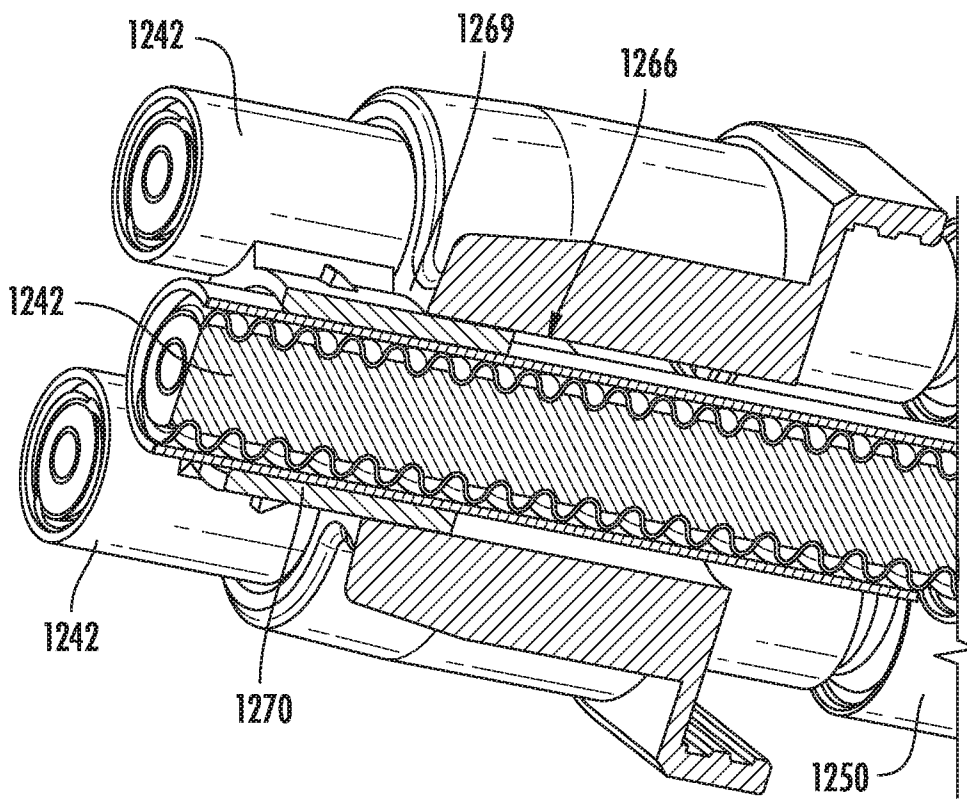
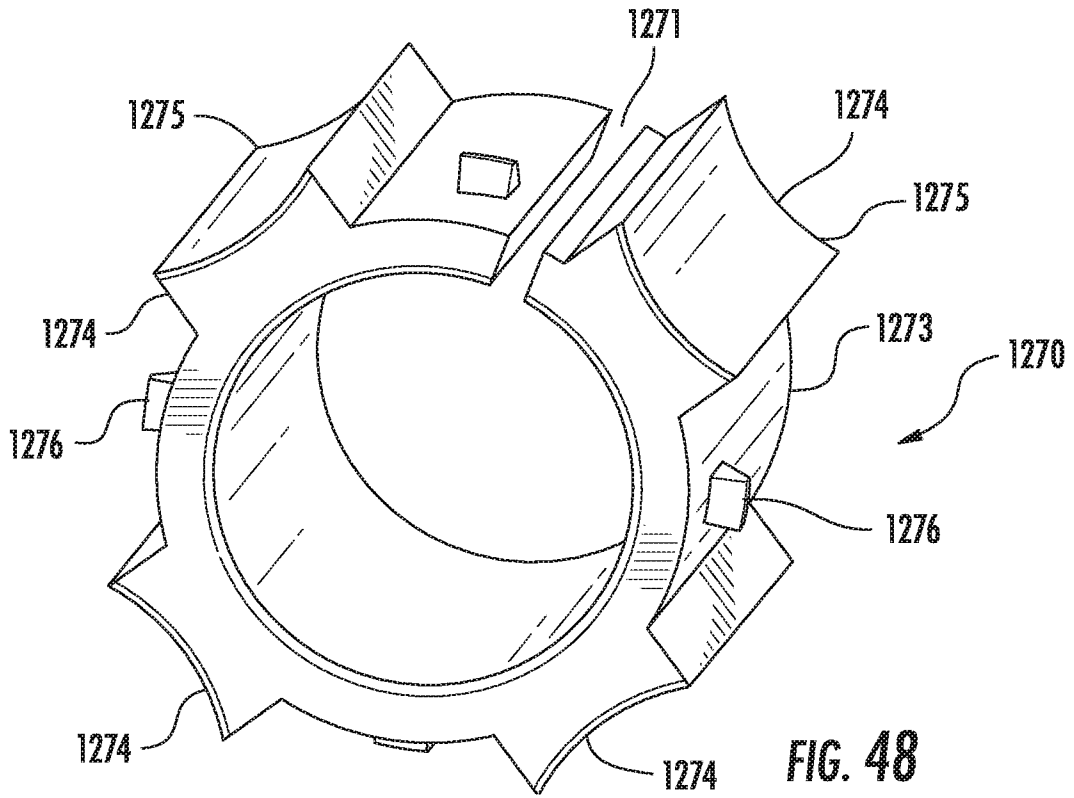

FIG. 49

26/34

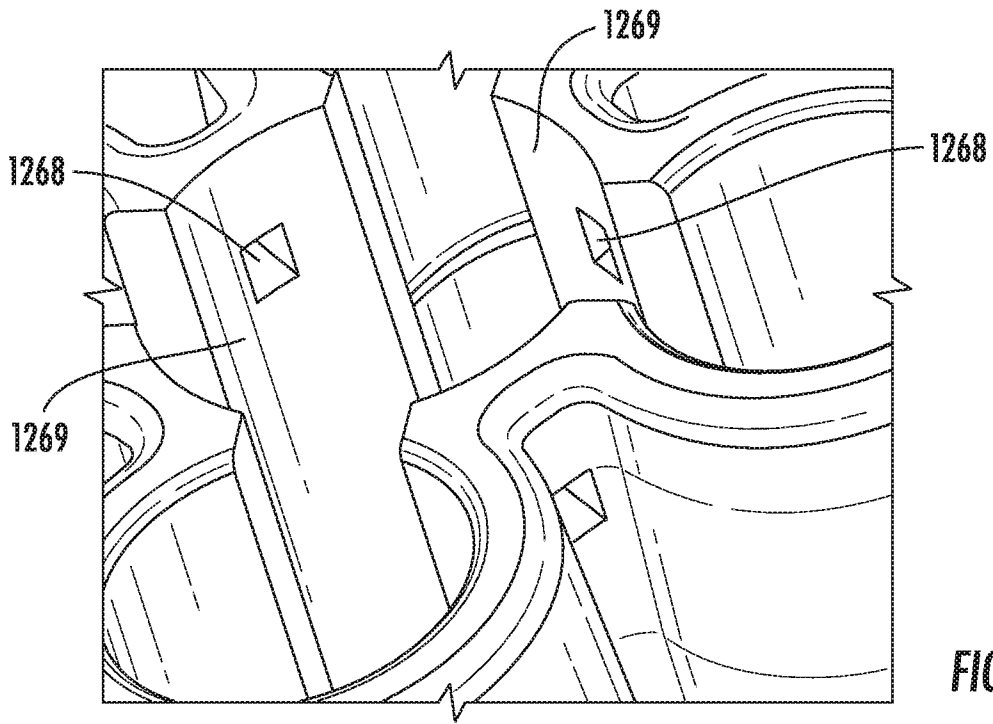

FIG. 50

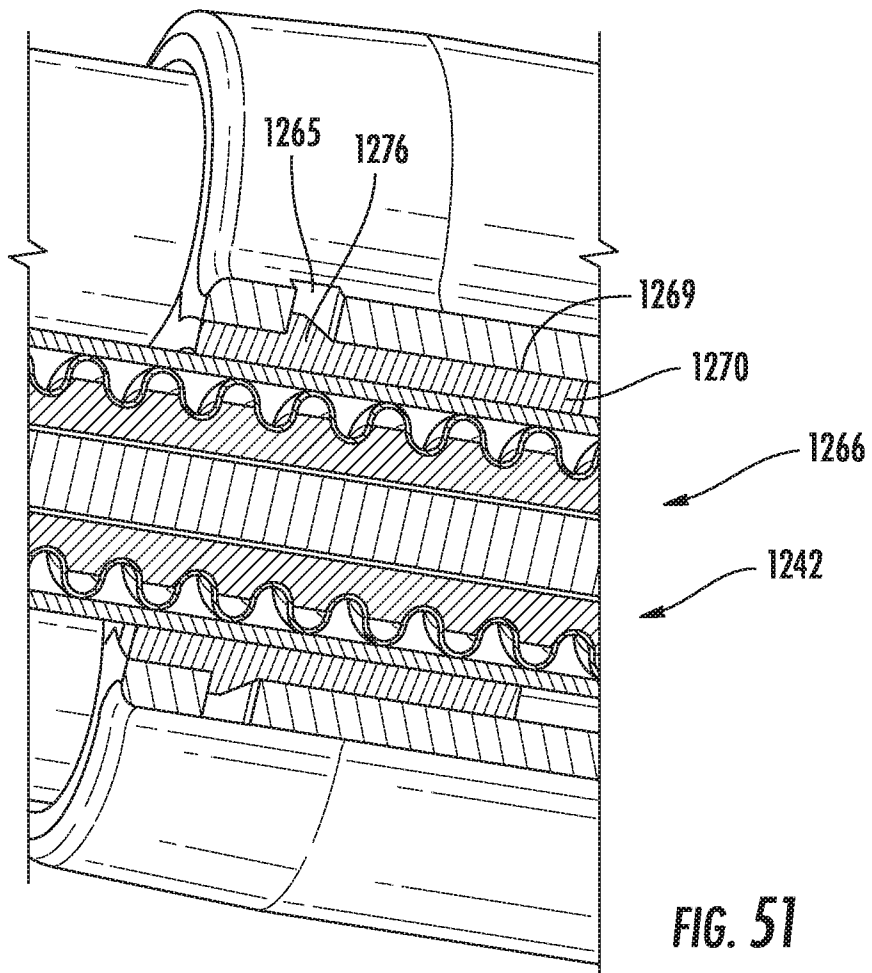
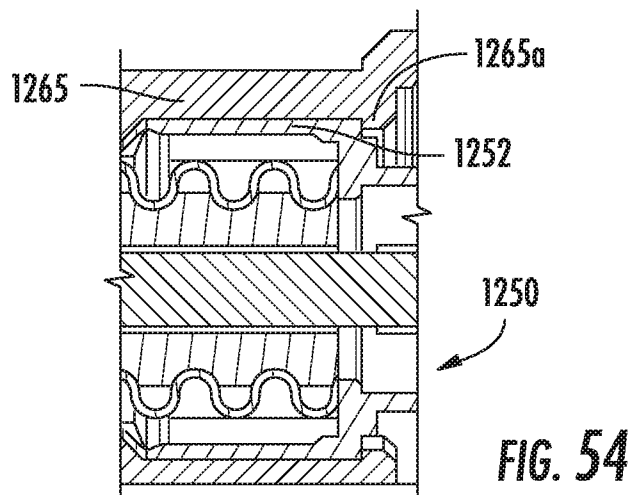
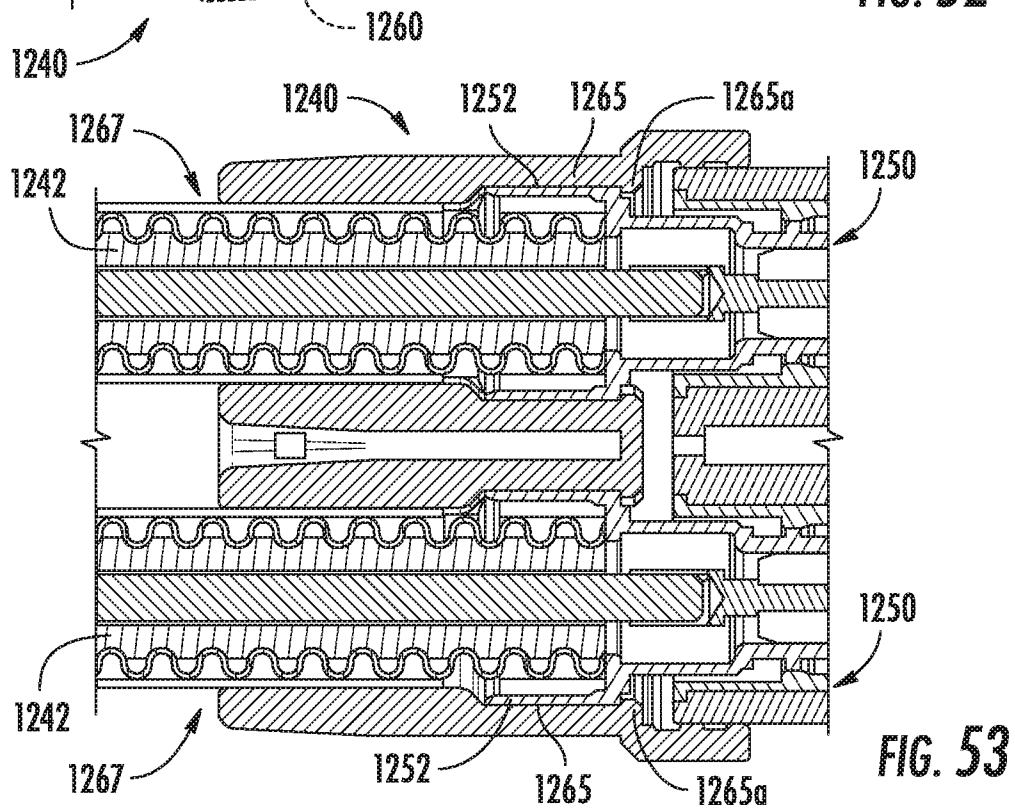
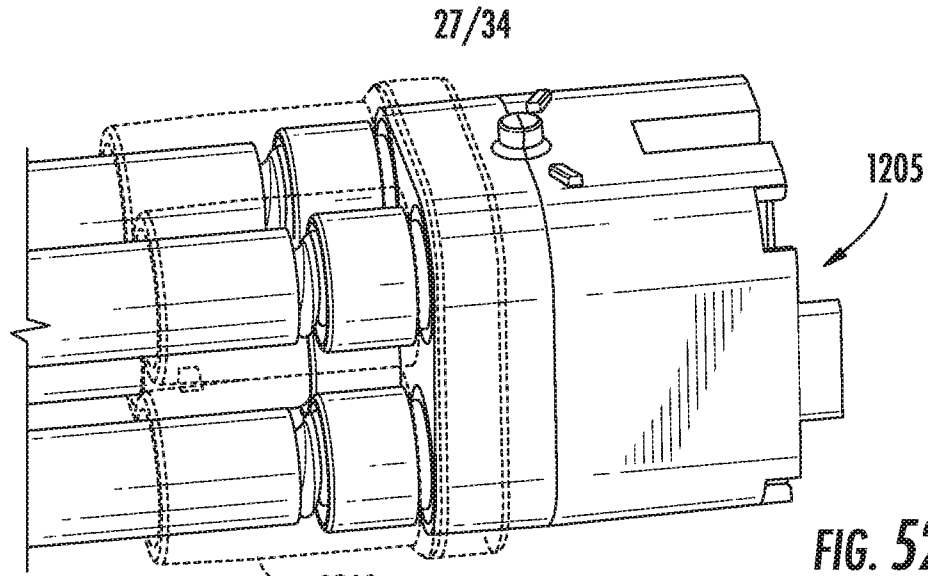
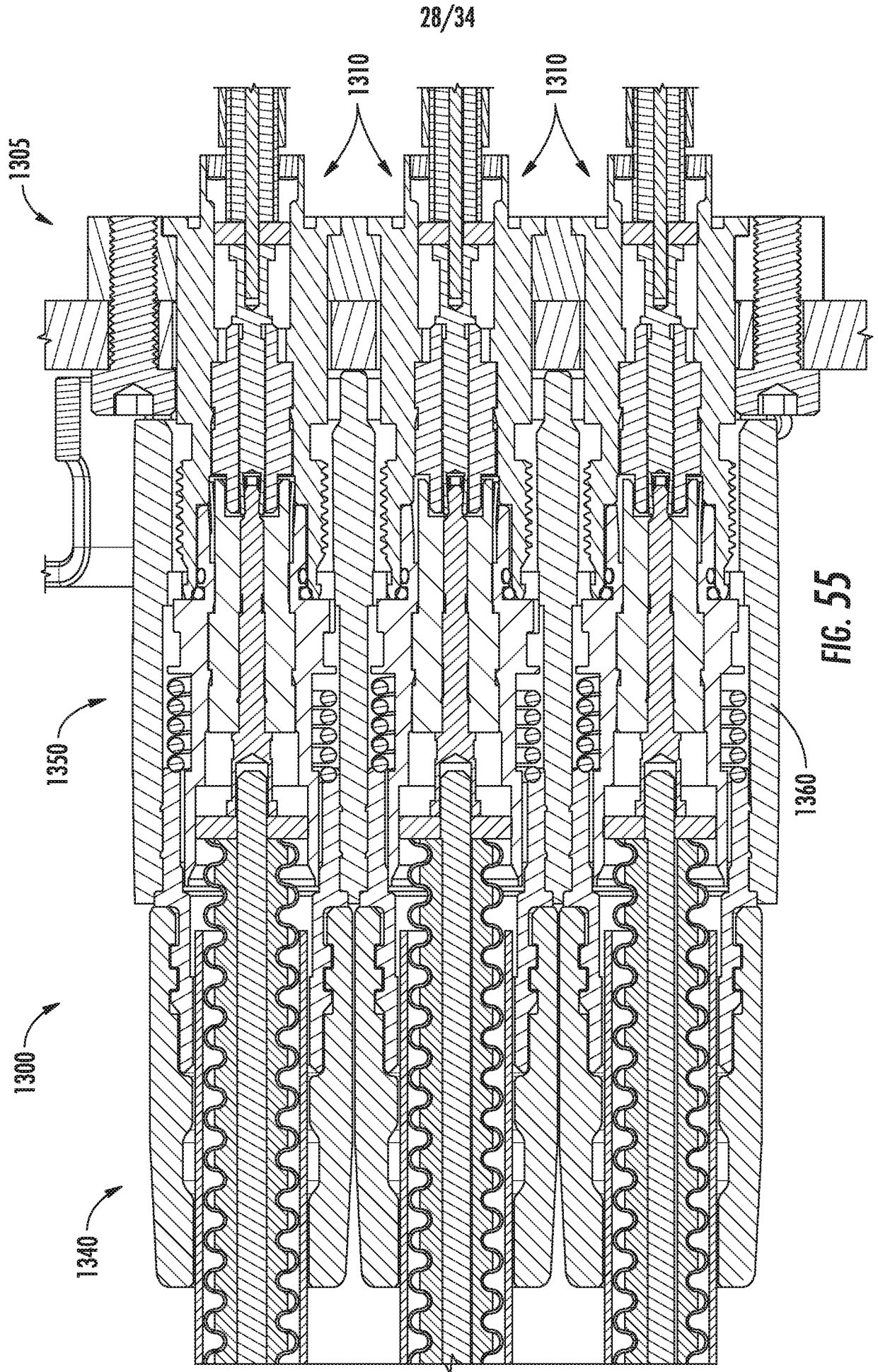

FIG. 51





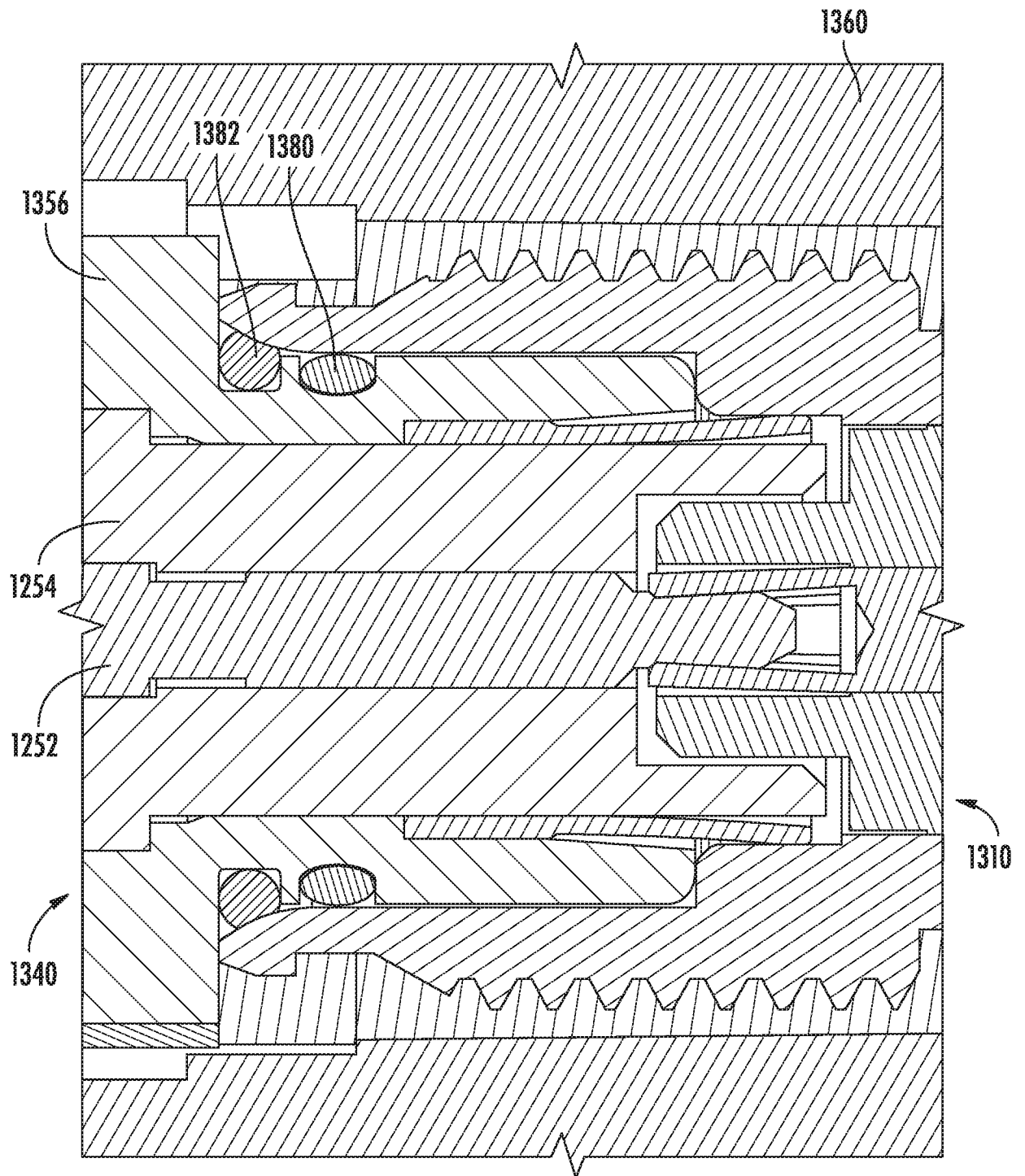

FIG. 56

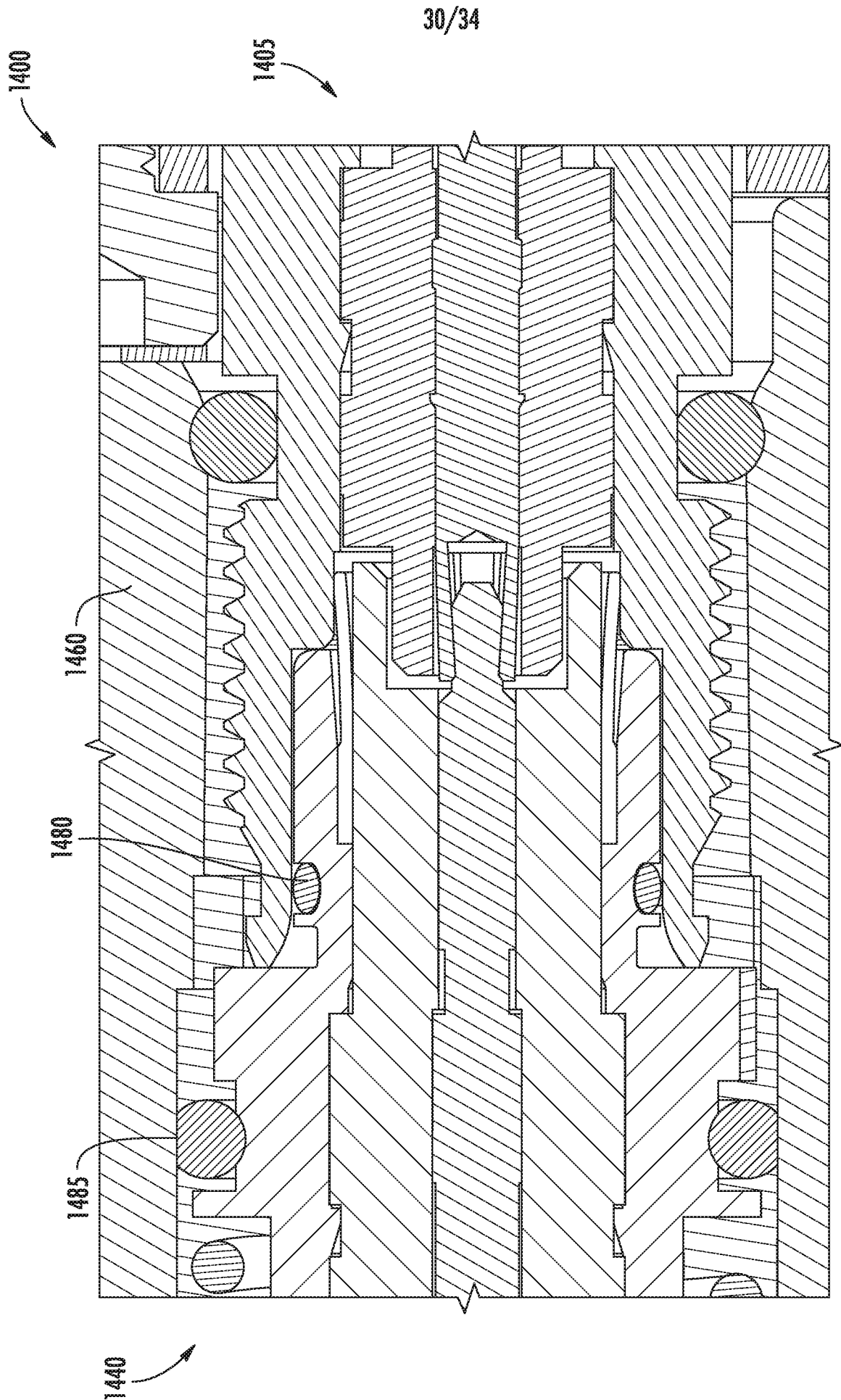

FIG. 57

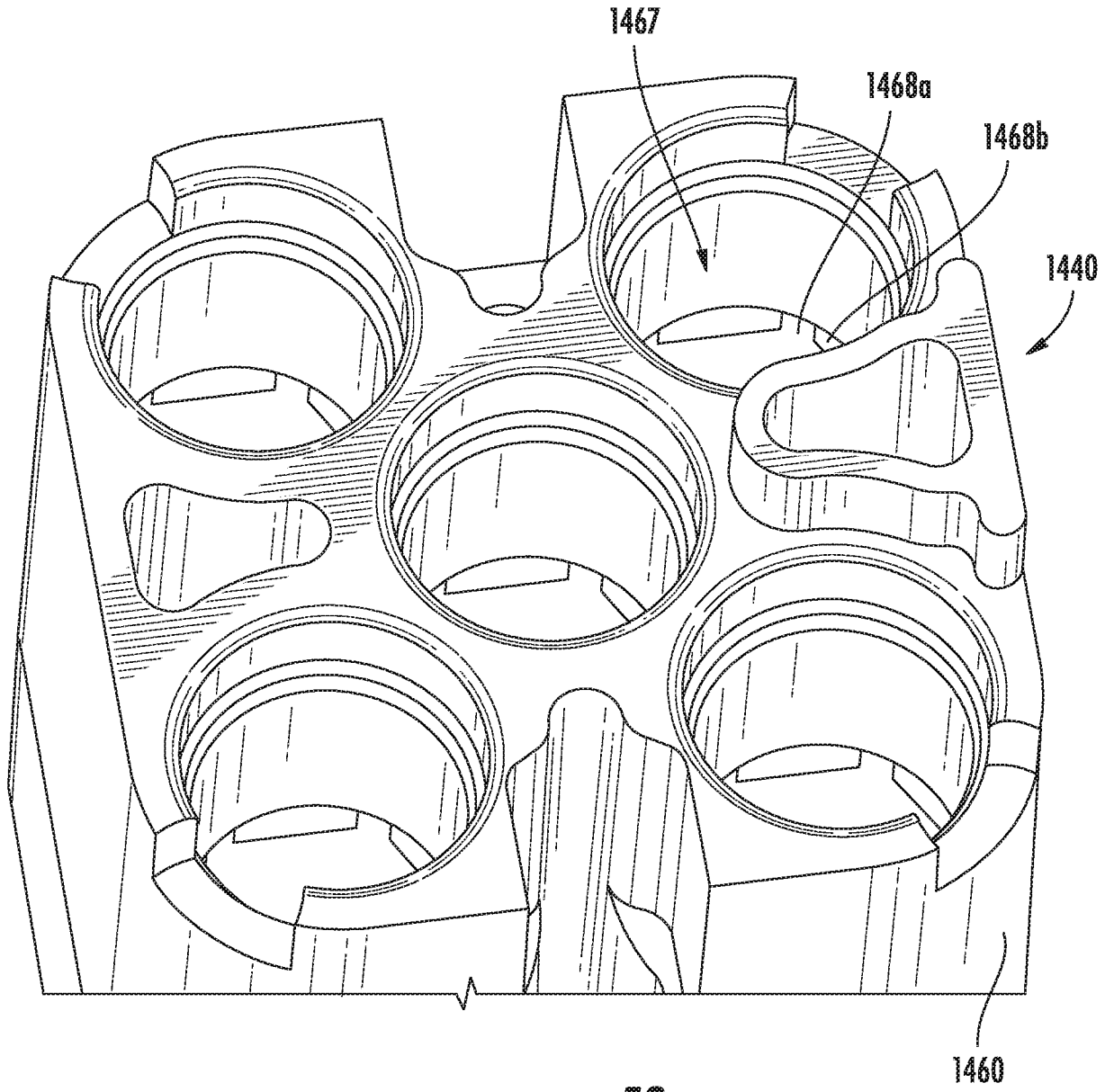

FIG. 58

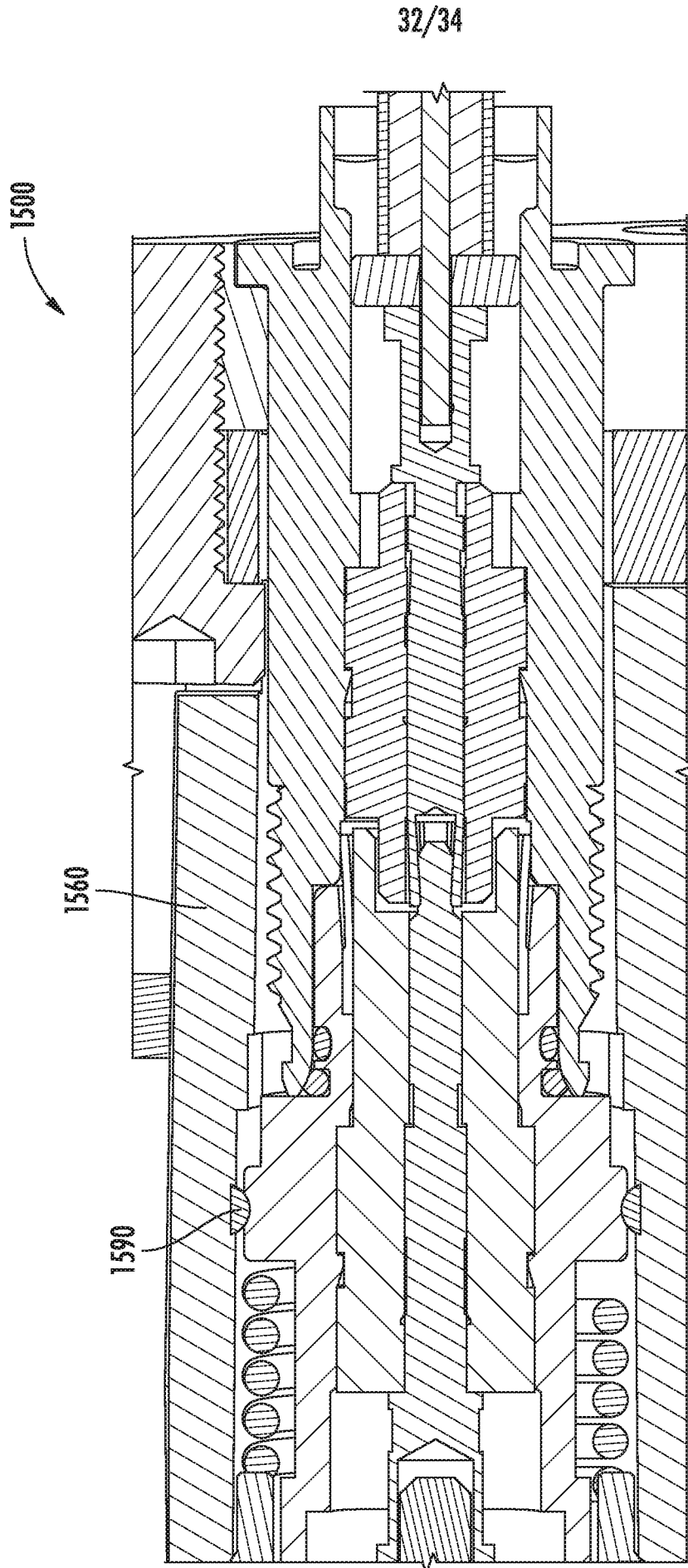
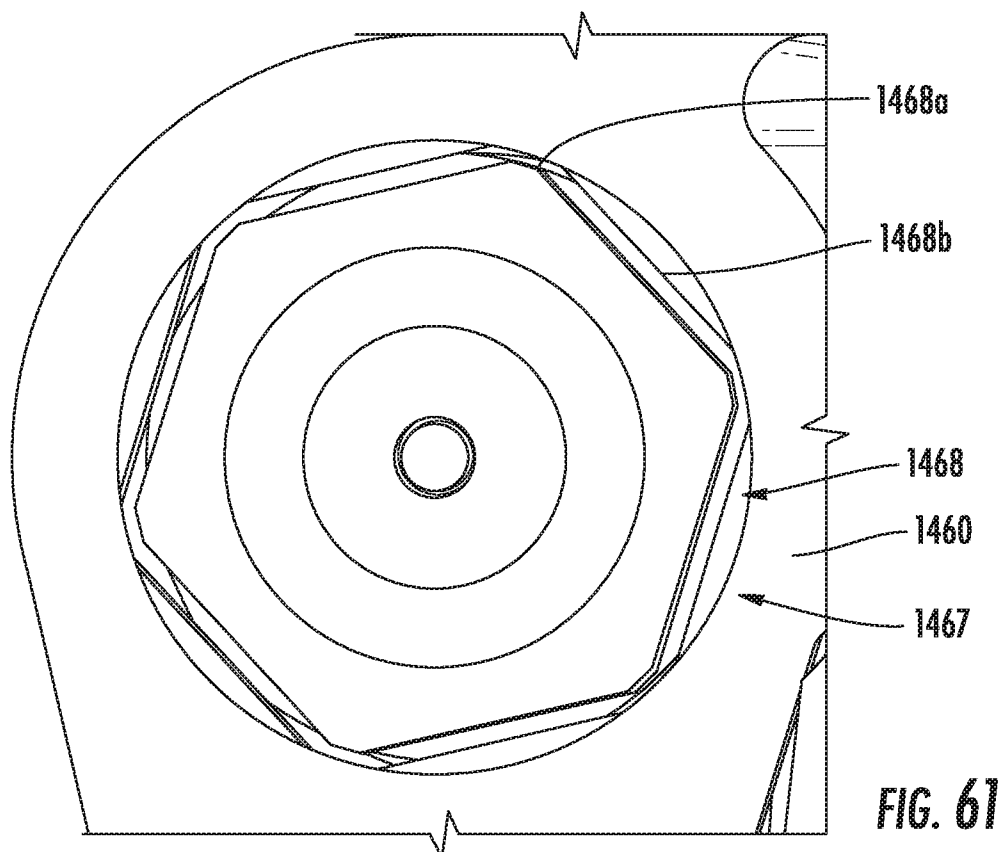
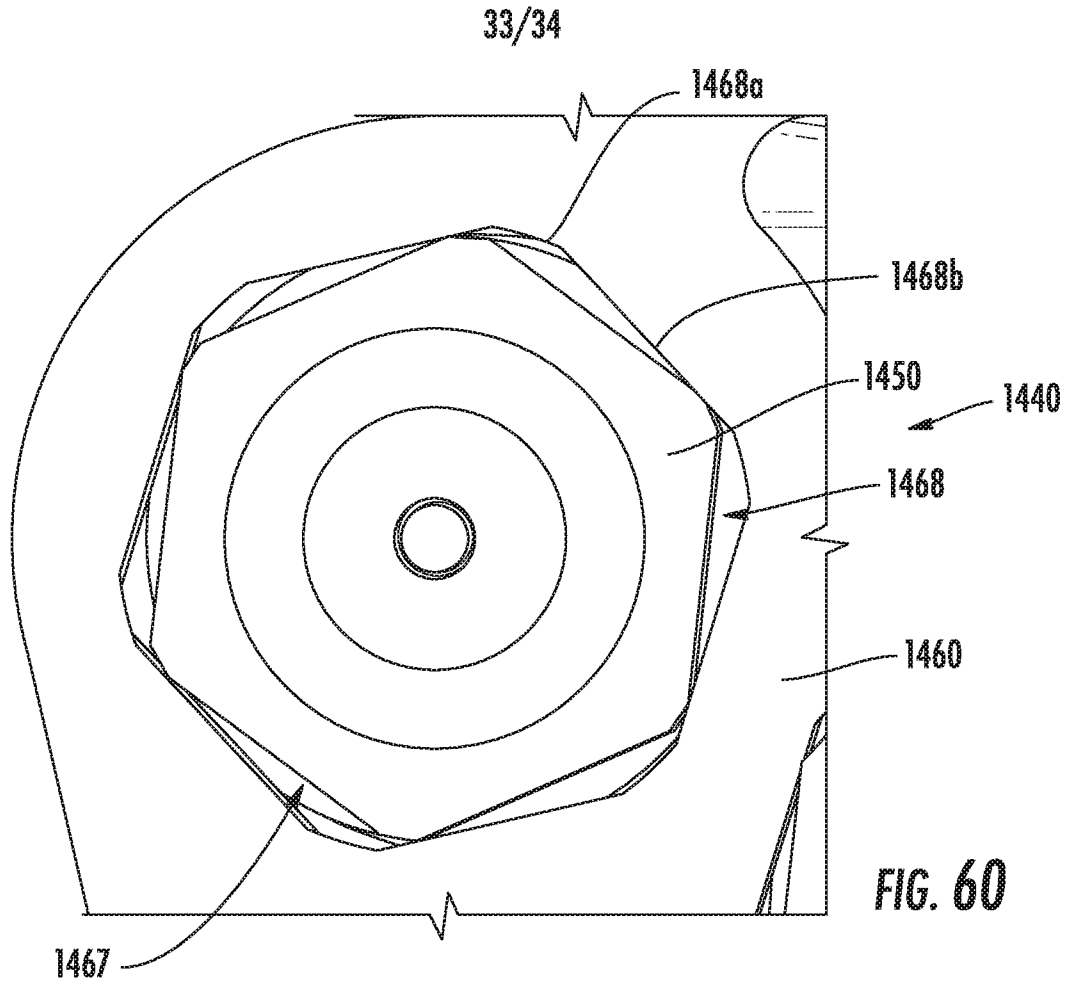

FIG. 59



34/34

