

(19) World Intellectual Property Organization  
International Bureau



(43) International Publication Date  
9 February 2012 (09.02.2012)

PCT

(10) International Publication Number  
**WO 2012/019139 A1**

(51) International Patent Classification:  
A61K 31/74 (2006.01)

(21) International Application Number:  
PCT/US2011/046817

(22) International Filing Date:  
5 August 2011 (05.08.2011)

(25) Filing Language: English

(26) Publication Language: English

(30) Priority Data:  
61/371,168 5 August 2010 (05.08.2010) US

(71) Applicant (for all designated States except US): **FOR-SIGHT VISION4, INC.** [US/US]; 191 Jefferson Dr., Menlo Park, California 90425 (US).

(72) Inventors; and

(75) Inventors/Applicants (for US only): **DE JUAN, Eugene** [US/US]; 191 Jefferson Dr., Menlo Park, California 90425 (US). **ALSTER, Yair** [IL/US]; 191 Jefferson Dr., Menlo Park, California 90425 (US). **FARINAS, Kathleen Cogan** [US/US]; 191 Jefferson Dr., Menlo Park, California 90425 (US). **REICH, Cary J.** [US/US]; 191 Jefferson Dr., Menlo Park, California 90425 (US). **CAMPBELL, Randolph E.** [US/US]; 191 Jefferson Dr., Menlo Park, California 90425 (US). **MACFARLANE, K. Angela** [NZ/US]; 191 Jefferson Dr., Menlo Park, California 90425 (US). **ERICKSON, Signe** [US/US]; 191 Jefferson Dr., Menlo Park, California 90425 (US).

(74) Agents: **BARRISH, Mark D.** et al.; Kilpatrick Townsend And Stockton LLP, Two Embarcadero Center, 8th Floor, San Francisco, California 94111 (US).

(81) Designated States (unless otherwise indicated, for every kind of national protection available): AE, AG, AL, AM, AO, AT, AU, AZ, BA, BB, BG, BH, BR, BW, BY, BZ, CA, CH, CL, CN, CO, CR, CU, CZ, DE, DK, DM, DO, DZ, EC, EE, EG, ES, FI, GB, GD, GE, GH, GM, GT, HN, HR, HU, ID, IL, IN, IS, JP, KE, KG, KM, KN, KP, KR, KZ, LA, LC, LK, LR, LS, LT, LU, LY, MA, MD, ME, MG, MK, MN, MW, MX, MY, MZ, NA, NG, NI, NO, NZ, OM, PE, PG, PH, PL, PT, QA, RO, RS, RU, SC, SD, SE, SG, SK, SL, SM, ST, SV, SY, TH, TJ, TM, TN, TR, TT, TZ, UA, UG, US, UZ, VC, VN, ZA, ZM, ZW.

(84) Designated States (unless otherwise indicated, for every kind of regional protection available): ARIPO (BW, GH, GM, KE, LR, LS, MW, MZ, NA, SD, SL, SZ, TZ, UG, ZM, ZW), Eurasian (AM, AZ, BY, KG, KZ, MD, RU, TJ, TM), European (AL, AT, BE, BG, CH, CY, CZ, DE, DK, EE, ES, FI, FR, GB, GR, HR, HU, IE, IS, IT, LT, LU, LV, MC, MK, MT, NL, NO, PL, PT, RO, RS, SE, SI, SK, SM, TR), OAPI (BF, BJ, CF, CG, CI, CM, GA, GN, GQ, GW, ML, MR, NE, SN, TD, TG).

Published:

- with international search report (Art. 21(3))
- before the expiration of the time limit for amending the claims and to be republished in the event of receipt of amendments (Rule 48.2(h))



WO 2012/019139 A1

(54) Title: COMBINED DRUG DELIVERY METHODS AND APPARATUS

(57) Abstract: Methods and apparatus provide treatment with a first therapeutic agent and a second therapeutic agent for an extended time. The first therapeutic agent may comprise a VEGF inhibitor and the second therapeutic agent may comprise an anti-inflammatory, such as a non-steroidal anti-inflammatory, for example a cyclooxygenase inhibitor. One or more of the first therapeutic agent or the second therapeutic agent can be injected into the eye, for example injected into a therapeutic device implanted into the eye to release the injected therapeutic agent for an extended time.

## COMBINED DRUG DELIVERY METHODS AND APPARATUS

### CROSS-REFERENCES TO RELATED APPLICATIONS

[0001] The present PCT application claims priority to U.S. Provisional Pat. App. Ser. No. 5 61/371168, filed 5 August 2010, the full disclosure of which is incorporated herein by reference.

### STATEMENT AS TO RIGHTS TO INVENTIONS MADE UNDER FEDERALLY SPONSORED RESEARCH AND DEVELOPMENT

[0002] NOT APPLICABLE

### 10 BACKGROUND OF THE INVENTION

[0003] The present invention relates to delivery of therapeutic agents to the posterior segment of the eye. Although specific reference is made to the delivery of macromolecules comprising antibodies or antibody fragments to the posterior segment of the eye, embodiments of the present invention can be used to deliver many therapeutic agents to many tissues of the body. 15 For example, embodiments of the present invention can be used to deliver therapeutic agent to one or more of the following tissues: intravascular, intra-articular, intrathecal, pericardial, intraluminal and gut.

[0004] The eye is critical for vision. The eye has a cornea and a lens that form an image on the retina. The image formed on the retina is detected by rods and cones. The light detected by 20 the rods and cones of the retina is transmitted to the occipital cortex brain via the optic nerve, such that the individual can see the image formed on the retina. Visual acuity is related to the density of rods and cones on the retina. The retina comprises a macula that has a high density of cones, such that the user can perceive color images with high visual acuity.

[0005] Unfortunately, diseases can affect vision. In some instances the disease affecting 25 vision can cause damage to the retina, even blindness in at least some instances. One example of a disease that can affect vision is age-related macular degeneration (hereinafter AMD). Although therapeutic drugs are known that can be provided to minimize degradation of the retina, in at least some instances the delivery of these drugs can be less than ideal.

[0006] In some instances a drug is injected into the eye through the sclera. One promising class of drugs for the treatment of AMD is known as vascular endothelial growth factor VEGF inhibitors. Unfortunately, in at least some instances injection of drugs can be painful for the patient, involve at least some risk of infection and hemorrhage and retinal detachment, and can  
5 be time consuming for the physician and patient. Consequently, in at least some instances the drug may be delivered less often than would be ideal, such that at least some patients may receive less drug than would be ideal in at least some instances.

[0007] Work in relation to embodiments of the present invention also suggests that an injection of the drug with a needle results in a bolus delivery of the drug, which may be less  
10 than ideal in at least some instances. For example, with a bolus injection of drug, the concentration of drug in the vitreous humor of the patient may peak at several times the required therapeutic amount, and then decrease to below the therapeutic amount before the next injection.

[0008] Although some implant devices have been proposed, many of the known devices are  
15 deficient in at least some respects in at least some instances. At least some of the known implanted devices do not provide sustained release of a therapeutic drug for an extended period. For example, at least some of the known implanted devices may rely on polymer membranes or polymer matrices to control the rate of drug release, and many of the known membranes and matrices may be incompatible with at least some therapeutic agents such as  
20 ionic drugs and large molecular weight protein drugs in at least some instances. At least some of the known semi-permeable polymer membranes may have permeability that is less than ideal for the extended release of large molecular weight proteins such as antibodies or antibody fragments. Also, work in relation to embodiments of the present invention also suggests that at least some of the known semi-permeable membranes can have a permeability of large  
25 molecules that may vary over time and at least some of the known semi-permeable membranes can be somewhat fragile, such that drug release for extended periods can be less than ideal in at least some instances. Although capillary tubes have been suggested for drug release, work in relation to embodiments of the present invention suggests that flow through capillary tubes can be less than ideal in at least some instances, for example possibly due to bubble formation and  
30 partial clogging.

[0009] At least some of the known implantable devices can result in patient side effects in at least some instances when a sufficient amount of drug is delivered to treat a condition of the eye. For example, at least some of the commercially available small molecule drug delivery devices may result in patient side effects such as cataracts, elevated intraocular pressure, dizziness or blurred vision in at least some instances. Although corticosteroids and analogues thereof may be delivered with an implanted device to treat inflammation, the drug delivery profile can be less than ideal such that the patient may develop a cataract in at least some instances.

[0010] Although at least some of the proposed implanted devices may permit an injection into the device, one potential problem is that an injection into an implanted device can cause at least some risk of infection for the patient in at least some instances. Also, in at least some instances the drug release rate of an implanted device can change over time, such that the release rate of the drug can be less than ideal after injection in at least some instance. At least some of the proposed implanted devices may not be implanted so as to minimize the risk of infection to the patient. For example, at least some of the proposed devices that rely on pores and capillaries may allow microbes such as bacteria to pass through the capillary and/or pore, such that infection may be spread in at least some instances. Also, work in relation to embodiments of the present invention suggests that at least some of the proposed implanted devices do not provide adequate protection from the patient's immune system, such as from macrophages and antibodies, thereby limiting the therapeutic effect in at least some instances.

[0011] In light of the above, it would be desirable to provide improved therapeutic devices and methods that overcome at least some of the above deficiencies of the known therapies, for example with improved drug release that can be maintained when implanted over an extended time.

#### SUMMARY OF THE INVENTION

[0012] Embodiments of the present invention provide therapeutic devices to deliver therapeutic amounts of one or more of a first therapeutic agent or a second therapeutic agent for an extended time to the posterior segment of the eye, for example an extended time of at least about 1 month. The first therapeutic agent may comprise an anti-neoplastic agent, such as an agent to inhibit neovascularization, for example a VEGF inhibitor. The second therapeutic



agent may comprise an anti-inflammatory, for example a cyclooxygenase (hereinafter "COX") inhibitor. While the first therapeutic agent and the second therapeutic agent can be delivered in many ways for the extended time, the therapeutic device may be helpful to reduce the frequency of negative side effects associated with direct intraocular injection such as pain, retinal detachment, hemorrhaging and infection because injections can be made less frequently and can be made into the reservoir chamber of the device rather than into the eye. The therapeutic device can be configured to replace the therapeutic agent when the device is implanted at least partially within the eye of the patient. The therapeutic device may be implanted in the eye so as to extend through the sclera of the eye, and the therapeutic device may comprise a container and a port or penetrable barrier configured to receive a quantity of therapeutic agent. The therapeutic agent can be placed in the container in many ways, for example by placing a solid insert through the port to the inside of the container or by injecting a formulation of the therapeutic agent through the penetrable barrier into the container.

**[0013]** One or more therapeutic devices can be configured in many ways to deliver one or more therapeutic agents for the extended time, such that the patient can be treated with fewer injections. A first therapeutic device may be injected with a first therapeutic agent and combined with injections of a second therapeutic agent into the vitreous humor to treat the eye. Alternatively or in combination, the first therapeutic device may be implanted on or near the pars plana of the eye with a second therapeutic device, and the first device may be aligned with the second device along the pars plana of the eye when the first device releases the first therapeutic agent for the extended time and the second therapeutic device releases the second therapeutic agent for the second extended time. The first therapeutic device may comprise the first therapeutic agent and the second therapeutic agent, such that the first therapeutic agent and the second therapeutic agent can be delivered from the first therapeutic device and the second therapeutic device may not be used in many embodiments. The first therapeutic agent may comprise an anti-neoplastic agent such as a VEGF inhibitor, and the second therapeutic agent may comprise an anti-inflammatory such as non-steroidal anti-inflammatory, for example a cyclooxygenase inhibitor.

**[0014]** In many embodiments, the therapeutic device is configured to provide continuous release of therapeutic quantities of the one or more therapeutic agents for an extended time of at

least 3 months, for example 6 months, such that the frequency of injections into the therapeutic device and risk of infection can be substantially decreased. In additional embodiments, the therapeutic device is configured to provide continuous release of therapeutic quantities of at least one therapeutic agent for an extended time of at least 12 months, or at least 2 years or at least 3 years.

[0015] The therapeutic device can be configured in many ways to release the one or more therapeutic agents for the extended time and may comprise at least one of an opening, an elongate structure, a porous structure, or a porous surface sized to release the therapeutic agent for the extended time. For example, the therapeutic device may comprise the porous structure to release the therapeutic agent through the porous structure for the extended period. The porous structure may comprise a sintered material having many channels, for example interconnecting channels, extending around many particles adhered to each other. The porous structure may comprise a first side comprising a first plurality of openings coupled to the reservoir and a second side comprising a second plurality of openings to couple to the vitreous humor. The interconnecting channels may extend between each of the first plurality of openings of the first side and each of the second plurality of openings of the second side so as to maintain release of the therapeutic agent through the porous structure, for example when at least some the openings are blocked. The porous structure can be rigid and maintain release of the therapeutic agent through the interconnecting channels when tissue or cells cover at least a portion of the openings, for example when the porous structure is implanted for an extended time and the drug reservoir refilled.

[0016] In many embodiments, the reservoir of the therapeutic device is flushable and/or refillable. This provides the added benefit that the physician may remove the therapeutic agent from the patient by flushing the agent from the reservoir of the therapeutic device rather than waiting for the therapeutic agent to be eliminated from the patient. This removal can be advantageous in cases where the patient has an adverse drug reaction or benefit from a pause in therapy sometimes referred to as a drug holiday. The volume of the reservoir and release rate of the porous structure can be tuned to receive a volume of a commercially available formulation, such that the therapeutic agent can be released for an extended time. For example, the volume of commercially available therapeutic agent may correspond to a bolus injection

having a treatment duration, for example one month, and the reservoir volume and release rate tuned to receive the formulation volume can extend the treatment duration of the injected volume by a factor of at least about two, for example from one month to two or more months.

5 [0017] In a first aspect, embodiments provide a method of treating an eye having a sclera and a vitreous humor. A first therapeutic amount of a first therapeutic agent is delivered to the vitreous humor of the eye, in which the first therapeutic agent effective for a first extended time. A second therapeutic amount of a second therapeutic agent is delivered, and the second therapeutic agent effective for a second extended time.

10 [0018] In many embodiments, the first therapeutic agent comprises an antineoplastic agent and effective for the first extended time and wherein the second therapeutic agent comprises one or more of a COX inhibitor, a LOX inhibitor, a TNF inhibitor, or an antihistamine.

[0019] In many embodiments, the first therapeutic agent comprises a vascular growth inhibitor effective for the first extended time and wherein the second therapeutic agent comprises an inflammatory response inhibitor effective for a second extended time.

15 [0020] In many embodiments, the vascular growth inhibitor comprising one or more of a VEGF inhibitor,

[0021] In many embodiments, the inflammatory response inhibitor comprises a cyclooxygenase (hereinafter "COX") inhibitor.

20 [0022] In many embodiments, the COX inhibitor comprises one or more of a salicylic acid derivative, a propionic acid derivative, an acetic acid derivative, and enolic acid (hereinafter "Oxicam") derivative, a fenamic acid derivative, a selective COX-2 inhibitor (hereinafter "Coxibs").

25 [0023] In many embodiments, the inflammatory response inhibitor comprises the propionic acid derivative and wherein the propionioic acid inhibitor comprises one or more of Ibuprofen, Naproxen, Fenoprofen, Ketoprofen, Flurbiprofen or Oxaprozin.

[0024] In many embodiments, the inflammatory response inhibitor comprises the acetic acid derivative and wherein the acetic acid derivative comprises one or more of Indomethacin, Sulindac, Etodolac, Diclofenac or Nabumetone.

[0025] In many embodiments, the inflammatory response inhibitor comprises the Enolic acid (hereinafter "Oxicam") derivatives and wherein the Enolic acid derivative comprises one or more of Piroxicam, Meloxicam, Tenoxicam, Droxicam, Lornoxicam, or Isoxicam.

5 [0026] In many embodiments, the inflammatory response inhibitor comprises the Fenamic acid derivative and wherein the Fenamic acid derivative comprises one or more of Mefenamic acid, Meclofenamic acid, Flufenamic acid, or Tolfenamic acid.

[0027] In many embodiments, the inflammatory response inhibitor comprises the Selective COX-2 inhibitor (hereinafter "Coxibs") and wherein the Selective COX-2 inhibitor comprises one or more of Celecoxib, Rofecoxib, Valdecoxib, Parecoxib, Lumiracoxib, or Etoricoxib.

10 [0028] In many embodiments, the first therapeutic agent is injected into the vitreous humor of the eye.

[0029] In many embodiments, the second therapeutic agent is injected into the vitreous humor of the eye.

15 [0030] In many embodiments, a container at least partially introduced through the sclera to couple the container to the vitreous humor and the sclera.

[0031] In many embodiments, the first therapeutic agent is injected into a chamber of the container when the container is coupled to the vitreous humor and the sclera and wherein the container is configured with a porous structure and a volume to release the first therapeutic amounts of the first therapeutic agent from the chamber into the vitreous humor for the first  
20 extended time.

[0032] In many embodiments, the second therapeutic agent is injected into a chamber of the container when the container is coupled to the vitreous humor and the sclera.

[0033] In many embodiments, the first therapeutic agent comprises a VEGF inhibitor and the second therapeutic agent comprises a cyclooxygenase inhibitor.

25 [0034] In many embodiments, the cyclooxygenase inhibitor comprises a solid coupled to the container to release the second therapeutic agent for the extended time.

[0035] In many embodiments, the solid cyclooxygenase inhibitor is located within the chamber of the container and released through the porous structure.

[0036] In many embodiments, the solid cyclooxygenase inhibitor is located within a second chamber of the container and released through a second porous structure.

5 [0037] In many embodiments, the second chamber is separated from the first chamber.

[0038] In many embodiments, the second chamber is coupled to the first chamber with the first porous structure and coupled to the vitreous with the second porous structure such that the first therapeutic agent passes through the first porous structure and second porous structure to reach the vitreous humor.

10 [0039] In many embodiments, the solid cyclooxygenase inhibitor is located away from the chamber and coupled to the vitreous humor.

[0040] In many embodiments, the container is configured to release the therapeutic amounts of the first therapeutic agent into the vitreous humor for the first extended time.

15 [0041] In many embodiments, the first therapeutic agent comprises a vascular growth inhibitor effective for the first extended time and wherein the second therapeutic agent comprises a lipooxygenase pathway (hereinafter "LOX") inhibitor effective for the second extended time.

[0042] In many embodiments, the LOX inhibitor comprises a 5-LOX inhibitor.

20 [0043] In many embodiments, the first therapeutic agent comprises a vascular growth inhibitor effective for the first extended time and wherein the second therapeutic agent comprises an antifibrotic agent effective for the second amount of time.

[0044] In many embodiments, the first therapeutic agent comprises a vascular growth inhibitor effective for the first extended time and wherein the second therapeutic agent comprises a tumor necrosis factor (hereinafter "TNF") inhibitor effective for the second  
25 extended time.

[0045] In many embodiments, the TNF inhibitor comprises pentoxifylline effective for the second extended time.

[0046] In many embodiments, the first therapeutic agent comprises a vascular growth inhibitor effective for the first extended time and wherein the second therapeutic agent comprises a dual COX/LOX inhibitor effective for the second extended time. [0047] In many embodiments, the dual COX/LOX inhibitor comprises Licofelone.

5 [0048] In many embodiments, the first therapeutic agent comprises a vascular growth inhibitor effective for the first extended time and wherein the second therapeutic agent comprises an antihistamine.

[0049] In many embodiments, the antihistamine comprises azelastine.

[0050] In many embodiments, the antihistamine comprises an H1-receptor antagonist.

10 [0051] In many embodiments, the H1-receptor antagonist comprises one or more of Clemastine, Diphenhydramine (Benadryl), Doxylamine, Loratadine, Desloratadine, Fexofenadine, Pheniramine, Cetirizine, Ebastine, Promethazine, Chlorpheniramine, Levocetirizine, Olopatadine, Quetiapine, Meclizine, Dimenhydrinate, embramine, dimethindene, or dexchlorpheniramine.

15 [0052] In many embodiments, the antihistamine comprises an H2-receptor antagonist.

[0053] In many embodiments, the H2-receptor antagonist comprises one or more of Cimetidine, Famotidine, Ranitidine, Nizatidine, Roxatidine, Lafutidine.

[0054] In many embodiments, the antihistamine comprises an H3-receptor antagonist.

20 [0055] In many embodiments, the H3-receptor antagonist comprises one or more of A-349,821, ABT-239, Ciproxifan, Clobenpropit, or Thioperamide.

[0056] In many embodiments, the antihistamine comprises an H4-receptor antagonist.

[0057] In many embodiments, the H4-receptor antagonist comprises one or more of Thioperamide, JNJ 7777120, or VUF-6002.

25 [0058] In another aspect, embodiments provide an apparatus to treat an eye having a sclera and a vitreous humor. A therapeutic device is configured to couple to the sclera. The therapeutic device comprises a first container to hold a first therapeutic agent, and the first container has a second therapeutic agent with in the container to release therapeutic amounts of

the second therapeutic agent into the vitreous humor for a second extended time when the therapeutic device is inserted into the eye.

5 [0059] In another aspect, embodiments provide an apparatus to treat an eye having a sclera and a vitreous humor. A therapeutic device is configured to couple to the sclera. The therapeutic device comprises a first container to hold a first therapeutic agent and a second container to hold a second therapeutic agent. The first container is configured to release first therapeutic amounts of the first therapeutic agent into the vitreous humor for a first extended time, and the second container is configured to release second therapeutic amounts of the second therapeutic agent into the vitreous humor for a second extended time.

10 [0060] In another aspect, an apparatus to treat an eye having a sclera and a vitreous humor comprises a first therapeutic device and a second therapeutic device. The first therapeutic device comprises a first container configured to couple to the sclera and hold a first therapeutic agent. The first container is configured to release first therapeutic amounts of the first therapeutic agent into the vitreous humor for a first extended time. The second therapeutic device comprises a second container configured to couple to the sclera and hold a second therapeutic agent. The second container configured to release second therapeutic amounts of the second therapeutic agent into the vitreous humor for a second extended time.

15 [0061] In many embodiments, the first therapeutic device and the second therapeutic device each comprises a portion to couple to the sclera having an oval cross section sized to fit an incision extending along the pars plana.

20 [0062] In many embodiments, the first therapeutic agent comprises a VEGF inhibitor and the second therapeutic agent comprises a COX inhibitor.

[0063] In many embodiments, the therapeutic device comprises a first chamber to receive an injection of the first therapeutic agent, and the first chamber is coupled to a first porous structure to contain the first therapeutic agent and release therapeutic amounts of the first therapeutic agent with a first release rate profile for the first extended time.

25 [0064] In many embodiments, the COX inhibitor comprises a substantially water insoluble COX inhibitor to release the therapeutic agent with a second release rate profile for the second extended time.

[0065] In many embodiments, further comprising a second chamber to the water insoluble COX inhibitor and a second porous structure coupled to the second chamber to release the water insoluble COX inhibitor through the second porous structure.

5 [0066] In many embodiments, the first chamber is coupled to the second chamber with the first porous structure, the first porous structure having a first release rate index, the second porous structure having a second release rate index, wherein the first release rate index is smaller than the second release rate index, such that the release rate profile of the first therapeutic agent is determined substantially based on the first release rate index and the release rate profile of the second therapeutic agent is determined substantially based on the second  
10 release rate index.

[0067] In another aspect, a therapeutic device to treat a patient, the device comprises means for releasing therapeutic amounts of a therapeutic agent for an extended period.

[0068] In a another aspect, a sustained drug delivery formulation comprising a first and second therapeutic agent wherein the first and second therapeutic agent is contained/disposed in  
15 a reservoir in at least one apparatus/therapeutic device of any one of claims 42 to 51, and at least one of the first and second therapeutic agent has a half-life within the reservoir when implanted, the half life within the reservoir substantially greater than a corresponding half-life of the at least one of the first and second therapeutic agent when injected directly into the vitreous of an eye.

20 [0069] In many embodiments, the device can be configured by selection of the reservoir volume and a porous structure with an appropriate rate release index to achieve the desired effective half-life.

[0070] In many embodiments, the rate release index is from about 0.01 to about 5.

[0071] In many embodiments, the first therapeutic agent is a VEGF-inhibitor and the second  
25 therapeutic agent is an inflammatory response inhibitor.

[0072] In many embodiments, the VEGF inhibitor is selected from the group consisting of Ranibizumab, Bevacizumab and Aflibercept™.

[0073] In many embodiments, the VEGF inhibitor is Ranibizumab.



[0074] In many embodiments, the inflammatory response inhibitor is selected from the group consisting of Piroxicam, Meloxicam, Tenoxicam, Droxicam, Lornoxicam, Isoxicam, Mefenamic acid, Meclofenamic acid, Flufenamic acid, and Tolfenamic acid.

5 [0075] In many embodiments, the inflammatory response inhibitor is selected from the group consisting of a cyclooxygenase (COX) inhibitor, a lipoxygenase (LOX) inhibitor and a tumor necrosis factor (TNF).

[0076] In many embodiments, the cox inhibitor is selected from the group consisting of celecoxib, valdecoxib, rofecoxib, parecoxib, lumiracoxib, etoricoxib, aspirin, ibuprofen, naproxen, fenoprofen, ketoprofen, flurbiprofen, oxaprozin, indomethacin, sulindac, etodolac,  
10 diclofenac, nabumetone, meloxicam, ketorolac, flurbiprofen, bromfenac, nepafenac, and amfenac.

[0077] In many embodiments, the lox inhibitor is selected from the group consisting of azelastine and zileuton.

[0078] In many embodiments, the TNF is selected from the group consisting of bupropion,  
15 pentoxifylline, infliximab, adalimumab, and etanercept.

[0079] In many embodiments, the concentration of the first therapeutic agent is greater than about 40 mg/ml.

[0080] In many embodiments, the concentration of the first therapeutic agent is from about 50 mg/ml to about 300 mg/ml.

20 [0081] In many embodiments, the concentration of the first therapeutic agent is about 100 mg/ml to about 250 mg/ml.

[0082] In many embodiments, the concentration of the first therapeutic agent is about 150 mg/ml to about 200 mg/ml.

[0083] In many embodiments, the amount of the first therapeutic agent is greater than about  
25 50 mg.

[0084] In many embodiments, at least one of the first or second therapeutic agent is administered in a sub-therapeutic dosage.

[0085] In many embodiments, at least one of the first or second therapeutic agent is contained/disposed in a micelle.

[0086] In many embodiments, at least one of the first and second therapeutic agent is stabilized by adsorption onto solid substrate or macromolecule that is capable of being flushed  
5 from the eye.

[0087] In many embodiments, the first and second therapeutic agents are contained/disposed in one apparatus/therapeutic device.

[0088] In many embodiments, the first therapeutic agent is contained/disposed in a first apparatus/therapeutic device and the second therapeutic agent is contained/disposed in a second  
10 apparatus/therapeutic device.

[0089] In many embodiments, the first and second therapeutic agents are administered simultaneously.

[0090] In many embodiments, the first and second therapeutic agents are administered sequentially.

15

#### BRIEF DESCRIPTION OF THE DRAWINGS

[0091] FIG. 1 shows an eye suitable for incorporation of the therapeutic device, in accordance with embodiments of the present invention;

[0092] FIG. 1A-1 shows a therapeutic device implanted at least partially within the sclera of the eye as in FIG. 1;

20 [0093] FIG. 1A-1-1 and 1A-1-2 show a therapeutic device implanted under the conjunctiva and extending through the sclera to release a therapeutic agent into vitreous humor of the eye so as to treat the retina of the, in accordance with embodiments of the present invention;

[0094] FIG. 1A-2 shows structures of a therapeutic device configured for placement in an eye as in FIGS. 1A-1 and 1A-1-1, according to embodiments of the present invention;

25 [0095] FIG. 1A-2-1 shows a therapeutic device loaded into an insertion cannula, in which the device comprises an elongate narrow shape for insertion into the sclera, and in which the device

is configured to expand to a second elongate wide shape for retention at least partially in the sclera;

[0096] FIG. 1A-2-2 shows a therapeutic device comprising a reservoir suitable for loading in a cannula;

5 [0097] FIG. 1B shows a therapeutic device configured for placement in an eye as in FIG. 1A-1 and 1A-1-1, in accordance with embodiments of the present invention;

[0098] FIG. 1C shows a therapeutic device configured for placement in an eye as in FIG. 1A-1 and 1A-1-1, in accordance with embodiments of the present invention;

10 [0099] FIG. 1C-A shows at least one exit port, according to embodiments of the present invention;

[0100] FIG. 1C-1 shows a method of removing a binding material, according to embodiments of the present invention;

[0101] FIG. 1C-2 and inserting the therapeutic agent with a second insert having the TA bound thereon;

15 [0102] FIG. 1C-3 shows syringe being filled with a commercially available formulation of therapeutic agent for injection into the therapeutic device, in accordance with embodiments;

[0103] Fig. 2 shows a first therapeutic agent contained in a first injector and a second therapeutic agent contained in a second injector to treat the patient;

20 [0104] Fig. 3 shows a first therapeutic agent contained in a first injector injected directly into the vitreous humor of the eye and a second therapeutic agent contained in a second injector injected into therapeutic device so as to treat the patient;

[0105] Fig. 4 shows a plurality of therapeutic devices implanted into the eye to deliver therapeutic amounts of first therapeutic agent and second therapeutic agent;

25 [0106] Fig. 5 shows a therapeutic device having a plurality of parallel reservoirs comprising a first reservoir and a second reservoir;

[0107] Fig. 6A shows a therapeutic device having a plurality of reservoirs configured in series comprising a first reservoir and a second reservoir;

[0108] FIG. 6B shows a rigid porous structure configured for sustained release with a device as in FIG. 6A;

[0109] FIG. 6B-1 shows interconnecting channels extending from a first side to a second side of the porous structure as in FIG. 6B;

5 [0110] FIG. 6B-2 shows a plurality of paths of the therapeutic agent along the interconnecting channels extending from a first side to a second side of the porous structure as in FIGS. 6B and 6B1;

[0111] FIG. 6B-3 shows blockage of the openings with a covering and the plurality of paths of the therapeutic agent along the interconnecting channels extending from a first side to a  
10 second side of the porous structure as in FIGS. 6B and 6B-1;

[0112] FIG. 6B-4 shows blockage of the openings with particles and the plurality of paths of the therapeutic agent along the interconnecting channels extending from a first side to a second side of the porous structure as in FIGS. 6B and 6B-1;

[0113] FIG. 6B-5 shows an effective cross-sectional size and area corresponding to the  
15 plurality of paths of the therapeutic agent along the interconnecting channels extending from a first side to a second side of the porous structure as in FIGS. 6B and 6B-1;

[0114] FIG. 6C shows a rigid porous structure as in FIG. 6B incorporated into a scleral tack;

[0115] FIG. 6D, shows a rigid porous structure as in FIG. 6B coupled with a reservoir for sustained release;

20 [0116] FIG. 6E shows a rigid porous structure as in FIG. 6B comprising a hollow body or tube for sustained release;

[0117] FIG. 6F shows a rigid porous structure as in FIG. 6B comprising a non-linear helical structure for sustained release;

[0118] FIG. 6G shows porous nanostructures, in accordance with embodiments;

25 [0119] FIG. 7 shows a therapeutic device coupled to an injector that removes material from the device and injects therapeutic agent into the device, according to embodiments;

[0120] Fig. 7A shows a therapeutic device having a reservoir tuned to receive an injection of a first amount of first therapeutic agent and a second amount of second therapeutic agent;

[0121] FIG. 7A-1 shows a therapeutic device coupled to an injector needle comprising a stop that positions the distal end of the needle near the proximal end of the device to flush the  
5 reservoir with ejection of liquid formulation through the porous frit structure, in accordance with embodiments;

[0122] FIG. 7A-2 shows a therapeutic device comprising a penetrable barrier coupled to an injector to inject and remove material from the device such that the liquid in the reservoir is exchanged with the injected formulation, in accordance with embodiments;

10 [0123] FIG. 7B-1 shows a side cross-sectional view of therapeutic device comprising a retention structure having a cross-section sized to fit in an elongate incision;

[0124] FIG. 7B-2 shows an isometric view of the therapeutic device as in FIG. 7B-1;

[0125] FIG. 7B-3 shows a top view of the therapeutic device as in FIG. 7B-1;

[0126] FIG. 7B-4 shows a side cross sectional view along the short side of the retention  
15 structure of the therapeutic device as in FIG. 7B-1;

[0127] FIG. 7B-5 shows a bottom view of the therapeutic device as in FIG. 7B-1 implanted in the sclera;

[0128] FIG. 7B-5A shows a cutting tool comprising a blade having a width corresponding to perimeter of the barrier and the perimeter of the narrow portion;

20 [0129] FIGS. 8A and 8A1 show a side cross sectional view and a top view, respectively, of the therapeutic device for placement substantially between the conjunctiva and the sclera;

[0130] Fig. 8A2 shows the therapeutic device implanted with the reservoir between the conjunctiva and the sclera, such that elongate structure extends through the sclera to couple the reservoir chamber to the vitreous humor;

25 [0131] Fig. 9 shows the porous structure of therapeutic device located in channel near the opening to the chamber of the container;

[0132] Fig. 10 shows the porous structure located within the chamber of container and coupled to the first opening of the elongate structure so as to provide the release rate profile;

[0133] Fig. 11 shows a plurality of injection ports spaced apart so as to inject and exchange the liquid of chamber of the container and inject the therapeutic agent into the reservoir  
5 chamber of the container; and

[0134] Fig. 12 shows the elongate structure coupled to the container away from the center of the container and near and located near an end of the container;

[0135] FIG. 13 shows the cumulative release of BSA protein through a sintered porous titanium cylinder;

10 [0136] FIG. 13-1 shows the measured cumulative release of BSA of FIG. 13 measured to 180 days;

[0137] FIG. 14 shows the cumulative release of BSA protein through a masked sintered porous titanium cylinder at Condition 1, in accordance with experimental embodiments;;

[0138] FIG. 15 shows cumulative release of BSA protein through a masked sintered porous  
15 titanium cylinder at Condition 2, in accordance with experimental embodiments;

[0139] FIG. 16 shows cumulative release of BSA protein through a masked sintered porous titanium cylinder at Condition 3, in accordance with experimental embodiments;;

[0140] FIG. 17 shows cumulative release of BSA through 0.1 media grade sintered porous stainless steel cylinder;

20 [0141] FIG. 18A shows cumulative release of BSA through 0.2 media grade sintered porous stainless steel cylinder;

[0142] FIG. 18B shows cumulative release of BSA through 0.2 media grade sintered porous stainless steel cylinder for 180 days;

[0143] FIG. 19A compares calculated Lucentis<sup>TM</sup> pharmacokinetics profiles to the  
25 pharmacokinetics profiles predicted for the device in Example 8;

[0144] FIG. 19B shows determined concentrations of ranibizumab in the vitreous humor for a first 50 uL Lucentis™ injection into a 25 uL reservoir of the device and a second 50 uL injection at 90 days, in accordance with embodiments;

5 [0145] FIG. 19C shows determined concentrations of ranibizumab in the vitreous humor for a first 50 uL Lucentis™ injection into a 32 uL reservoir of the device and a second 50 uL injection at 90 days, in accordance with embodiments;

[0146] FIG. 19D shows determined concentrations of ranibizumab in the vitreous humor for a first 50 uL Lucentis™ injection into a 50 uL reservoir of the device and a second 50 uL injection at 90 days, in accordance with embodiments;

10 [0147] FIG. 19E shows determined concentrations of ranibizumab in the vitreous humor for a first 50 uL Lucentis™ injection into a 50 uL reservoir of the device and a second 50 uL injection at 130 days, in accordance with embodiments;

[0148] FIG. 19F shows determined concentrations of ranibizumab in the vitreous humor for a 50 uL Lucentis™ injection into a 50 uL device having a release rate index of 0.05, in  
15 accordance with embodiments;

[0149] FIG. 19G shows determined concentrations of ranibizumab in the vitreous humor for a 50 uL Lucentis™ injection into a 75 uL device having a release rate index of 0.05, in accordance with embodiments;

[0150] FIG. 19H shows determined concentrations of ranibizumab in the vitreous humor for  
20 a 50 uL Lucentis™ injection into a 100 uL device having a release rate index of 0.05, in accordance with embodiments;

[0151] FIG. 19I shows determined concentrations of ranibizumab in the vitreous humor for a 50 uL Lucentis™ injection into a 125 uL device having a release rate index of 0.05, in accordance with embodiments;

25 [0152] FIG. 19J shows determined concentrations of ranibizumab in the vitreous humor for a 50 uL Lucentis™ injection into a 150 uL device having a release rate index of 0.05, in accordance with embodiments;

[0153] FIG. 19K shows determined concentrations of ranibizumab in the vitreous humor for a 50 uL Lucentis™ injection into a 100 uL device having a release rate index of 0.1, in accordance with embodiments;

5 [0154] FIG. 19L shows determined concentration profiles of ranibizumab in the vitreous humor for a 50 uL Lucentis™ injection into a 125 uL reservoir device having a release rate index of 0.105, in accordance with embodiments;

[0155] FIG. 19M shows determined concentration profiles of ranibizumab in the vitreous humor for a 50 uL Lucentis™ injection into a 125 uL reservoir device having a release rate index of 0.095, in accordance with embodiments;

10 [0156] FIG. 19N shows determined concentration profiles of ranibizumab in the vitreous humor for a 50 uL Lucentis™ injection into a 125 uL reservoir device having a release rate index of 0.085, in accordance with embodiments;

[0157] FIG. 19O shows determined concentration profiles of ranibizumab in the vitreous humor for a 50 uL Lucentis™ injection into a 125 uL reservoir device having a release rate  
15 index of 0.075, in accordance with embodiments;

[0158] FIG. 19P shows determined concentration profiles of ranibizumab in the vitreous humor for a 50 uL Lucentis™ injection into a 125 uL reservoir device having a release rate index of 0.065, in accordance with embodiments;

[0159] FIG. 19Q shows determined concentrations of ranibizumab in the vitreous humor for  
20 a 10 uL concentrated Lucentis™ (40 mg/mL) injection into a 10 uL device having a release rate index of 0.01 and in which the ranibizumab has a half life in the vitreous humor of about nine days, in accordance with embodiments;

[0160] FIG. 19R shows determined concentrations of ranibizumab in the vitreous humor for a  
25 10 uL concentrated Lucentis™ (40 mg/mL) injection into a 10 uL device having a release rate index of 0.01 and in which the ranibizumab has a half life in the vitreous humor of about five days, in accordance with embodiments;

[0161] FIG. 19S shows determined concentrations of ranibizumab in the vitreous humor for a 10 uL standard Lucentis™ (10 mg/mL) injection into a 10 uL device having a release rate



index of 0.01 and in which the ranibizumab has a half life in the vitreous humor of about nine days, in accordance with embodiments;

[0162] FIG. 19T shows determined concentrations of ranibizumab in the vitreous humor for a 10 uL standard Lucentis™ (10 mg/mL) injection into a 10 uL device having a release rate  
5 index of 0.01 and in which the ranibizumab has a half life in the vitreous humor of about five days, in accordance with embodiments;

[0163] FIG. 20 shows a calculated time release profile of a therapeutic agent suspension in a reservoir, in accordance with embodiments.

[0164] FIG. 21 shows cumulative release for Avastin™ with therapeutic devices comprising  
10 substantially similar porous frit structures and a 16 uL reservoir and a 33 uL reservoir;

[0165] FIG. 22A shows cumulative release for Avastin™ with porous frit structures having a thickness of 0.049”;

[0166] FIG. 22B-1 shows cumulative release for Avastin™ with porous frit structures having a thickness of 0.029”;

15 [0167] FIG. 22B-2 shows rate of release for Avastin™ with porous frit structures having a thickness of 0.029” as in FIG. 22B-1;

[0168] FIG. 23A shows cumulative release for Avastin™ with a reservoir volume of 20 uL;

[0169] FIG. 23A-1 shows cumulative release to about 90 days for Avastin™ with a reservoir volume of 20 uL as in FIG. 23A;

20 [0170] FIG. 23B shows rate of release as in FIG. 23A;

[0171] FIG. 23B-1 shows rate of release as in FIG. 23A-1;

[0172] FIG. 24A shows cumulative release for Avastin™ with a 0.1 media grade porous frit structure;

[0173] FIG. 24A-1 shows cumulative release to about 90 days release for Avastin™ with a  
25 0.1 media grade porous frit structure as in FIG. 24A;

[0174] FIG. 24B shows rates of release of the devices as in FIG. 24A;

[0175] FIG. 24B-1 shows rates of release of the devices as in FIG. 24A-1;

[0176] FIG. 25A shows cumulative release for fluorescein through a 0.2 media grade porous frit structure;

5 [0177] FIG. 25A-1 shows cumulative release to about 90 days for fluorescein through a 0.2 media grade porous frit structure as in FIG. 25A;

[0178] FIG. 25B shows rates of release of the devices as in FIG. 25A;

[0179] FIG. 25B-1 shows rates of release of the devices as in FIG. 25A-1;

10 [0180] FIG. 25C shows cumulative release to about thirty days for Lucentis™ through a 0.2 media grade porous frit structure having a diameter of 0.038 in and a length (thickness) of 0.029 in.;

[0181] FIG. 25D shows rates of release of the devices as in FIG. 25C;

[0182] FIG. 25E shows cumulative release to about thirty days for Lucentis™ for 30 uL devices having a RRI's from about 0.015 to about 0.090;

[0183] FIG. 25F shows rates of release of the devices as in FIG. 25E;

15 [0184] FIGS. 26A and 26B show scanning electron microscope images from fractured edges of porous frit structures so as to show the structure of the porous structure to release the therapeutic agent, in accordance with embodiments;

[0185] FIGS. 27A and 27B show scanning electron microscope images from surfaces of porous frit structures, in accordance with embodiments;

20 [0186] FIG. 28 shows a pressure decay test and test apparatus for use with a porous structure so as to identify porous frit structures suitable for use with therapeutic devices in accordance with embodiments described herein; and

25 [0187] FIG. 29 shows a pressure flow test and test apparatus suitable for use with a porous structure so as to identify porous frit structures suitable for use with therapeutic devices in accordance with embodiments described herein.

## DETAILED DESCRIPTION OF THE INVENTION

5 [0188] Although specific reference is made to the delivery of macromolecules comprising antibodies or antibody fragments to the posterior segment of the eye, embodiments of the present invention can be used to deliver many therapeutic agents to many tissues of the body. For example, embodiments of the present invention can be used to deliver therapeutic agent for an extended period to one or more of the following tissues: intravascular, intra articular, intrathecal, pericardial, intraluminal and gut.

10 [0189] The therapeutic agents and devices as described herein can be used to deliver combinations of therapeutic agents for an extended time. The combined therapeutic agents can be used to treat many disease of the eye, for example age related macular degeneration (hereinafter "AMD").

15 [0190] The embodiments as described herein may incorporate one or more components of the methods and apparatus described in U.S. App. Ser. No. 12/696,678, filed January 29, 2010, entitled "Posterior Segment Drug Delivery", published as U.S. Pat. App. Pub. No. 2010/0255061 (attorney docket not. 026322-003750US); PCT/US2010/022631, published as WO2010/088548, entitled "Posterior Segment Drug Delivery"; and priority U.S. Provisional Pat. App. Ser. No. 61/371168, filed 5 August 2010, the full disclosures of which are incorporated by reference.

20 [0191] Embodiments of the present invention provide sustained release of a therapeutic agent to the posterior segment of the eye or the anterior segment of the eye, or combinations thereof. Therapeutic amounts of a therapeutic agent can be released into the vitreous humor of the eye, such that the therapeutic agent can be transported by at least one of diffusion or convection to the retina or other ocular tissue, such as the choroid or ciliary body, for therapeutic effect.

25 [0192] As used herein the release rate index encompasses  $(PA/FL)$  where P comprises the porosity, A comprises an effective area, F comprises a curve fit parameter corresponding to an effective length and L comprises a length or thickness of the porous structure. The units of the release rate index (RRI) comprise units of mm unless indicated otherwise and can be

determined by a person of ordinary skill in the art in accordance with the teachings described hereon.

[0193] As used herein, sustained release encompasses release of therapeutic amounts of an active ingredient of a therapeutic agent for an extended period of time. The sustained release  
5 may encompass first order release of the active ingredient, zero order release of the active ingredient, or other kinetics of release such as intermediate to zero order and first order, or combinations thereof.

[0194] As used herein a therapeutic agent referred to with a trade name encompasses one or more of the formulation of the therapeutic agent commercially available under the tradename,  
10 the active ingredient of the commercially available formulation, the generic name of the active ingredient, or the molecule comprising the active ingredient.

[0195] As used herein, similar numerals indicate similar structures and/or similar steps.

[0196] As used herein, the terms first and second identify components of combinations and can be in any order, for example reversed, or simultaneous, in accordance with the teachings  
15 and embodiments described herein.

[0197] As used herein, a therapeutic device implanted in the eye encompasses at least a portion of the therapeutic device placed under the conjunctiva of the eye.

[0198] The therapeutic agent may be contained within a chamber of a container, for example within a reservoir comprising the container and chamber. The therapeutic agent may comprise  
20 a formulation such as solution of therapeutic agent, a suspension of a therapeutic agent or a dispersion of a therapeutic agent, for example. Examples of therapeutic agents suitable for use in accordance with embodiments of the therapeutic device are described herein, for example with reference to Table 1A below and elsewhere.

[0199] The therapeutic agent may comprise a macromolecule, for example an antibody or  
25 antibody fragment. The therapeutic macromolecule may comprise a VEGF inhibitor, for example commercially available Lucentis<sup>TM</sup>. The VEGF (Vascular Endothelial Growth Factor) inhibitor can cause regression of the abnormal blood vessels and improvement of vision when

released into the vitreous humor of the eye. Examples of VEGF inhibitors include Lucentis<sup>TM</sup>, Avastin<sup>TM</sup>, Macugen<sup>TM</sup>, and VEGF Trap.

5 [0200] The therapeutic agent may comprise small molecules such as of a corticosteroid and analogues thereof. For example, the therapeutic corticosteroid may comprise one or more of triamcinolone, triamcinolone acetonide, dexamethasone, dexamethasone acetate, fluocinolone, fluocinolone acetate, or analogues thereof. Alternatively or in combination, the small molecules of therapeutic agent may comprise a tyrosine kinase inhibitor comprising one or more of axitinib, bosutinib, cediranib, dasatinib, erlotinib, gefitinib, imatinib, lapatinib, lestaurtinib, nilotinib, semaxanib, sunitinib, toceranib, vandetanib, or vatalanib, for example.

10 [0201] The therapeutic agent may comprise an anti-VEGF therapeutic agent. Anti-VEGF therapies and agents can be used in the treatment of certain cancers and in age-related macular degeneration. Examples of anti-VEGF therapeutic agents suitable for use in accordance with the embodiments described herein include one or more of monoclonal antibodies such as bevacizumab (Avastin<sup>TM</sup>) or antibody derivatives such as ranibizumab (Lucentis<sup>TM</sup>), or small  
15 molecules that inhibit the tyrosine kinases stimulated by VEGF such as lapatinib (Tykerb<sup>TM</sup>), sunitinib (Sutent<sup>TM</sup>), sorafenib (Nexavar<sup>TM</sup>), axitinib, or pazopanib.

[0202] The therapeutic agent may comprise a therapeutic agent suitable for treatment of dry AMD such as one or more of Sirolimus<sup>TM</sup> (Rapamycin), Copaxone<sup>TM</sup> (Glatiramer Acetate), Othera<sup>TM</sup>, Complement C5aR blocker, Ciliary Neurotrophic Factor, Fenretinide or  
20 Rheopheresis.

[0203] The therapeutic agent may comprise a therapeutic agent suitable for treatment of wet AMD such as one or more of REDD14NP (Quark), Sirolimus<sup>TM</sup> (Rapamycin), ATG003; Regeneron<sup>TM</sup> (VEGF Trap) or complement inhibitor (POT-4).

25 [0204] The therapeutic agent may comprise a kinase inhibitor such as one or more of bevacizumab (monoclonal antibody), BIBW 2992 (small molecule targeting EGFR/Erb2), cetuximab (monoclonal antibody), imatinib (small molecule), trastuzumab (monoclonal antibody), gefitinib (small molecule), ranibizumab (monoclonal antibody), pegaptanib (small molecule), sorafenib (small molecule), dasatinib (small molecule), sunitinib (small molecule), erlotinib (small molecule), nilotinib (small molecule), lapatinib (small molecule), panitumumab

(monoclonal antibody), vandetanib (small molecule) or E7080 (targeting VEGFR2/VEGFR2, small molecule commercially available from Esai, Co.)

[0205] The amount of therapeutic agent within the therapeutic device may comprise from about 0.01 mg to about 1 mg, for example Lucentis™, so as to provide therapeutic amounts of the therapeutic agent for the extended time, for example at least 30 days. The extended time may comprise at least 90 days or more, for example at least 180 days or for example at least 1 year, at least 2 years or at least 3 years or more. The target threshold therapeutic concentration of a therapeutic agent such as Lucentis™ in the vitreous may comprise at least a therapeutic concentration of 0.1 ug/mL. For example the target threshold concentration may comprise from about 0.1 ug/mL to about 5 ug/mL for the extended time, where the upper value is based upon calculations shown in Example 9 using published data. The target threshold concentration is drug dependent and thus may vary for other therapeutic agents.

[0206] The delivery profile may be configured in many ways to obtain a therapeutic benefit from the sustained release device. For example, an amount of the therapeutic agent may be inserted into the container at monthly intervals so as to ensure that the concentration of therapeutic device is above a safety protocol or an efficacy protocol for the therapeutic agent, for example with monthly or less frequent injections into the container. The sustained release can result in an improved delivery profile and may result in improved results. For example, the concentration of therapeutic agent may remain consistently above a threshold amount, for example 0.1 ug/mL, for the extended time.

[0207] The insertion method may comprise inserting a dose into the container of the therapeutic device. For example, a single injection of Lucentis™ may be injected into the therapeutic device.

[0208] The duration of sustained delivery of the therapeutic agent may extend for twelve weeks or more, for example four to six months from a single insertion of therapeutic agent into the device when the device is inserted into the eye of the patient.

[0209] The therapeutic agent may be delivered in many ways so as to provide a sustained release for the extended time. For example, the therapeutic device may comprise a therapeutic agent and a binding agent. The binding agent may comprise small particles configured to

couple releasably or reversibly to the therapeutic agent, such that the therapeutic agent is released for the extended time after injection into the vitreous humor. The particles can be sized such that the particles remain in the vitreous humor of the eye for the extended time.

5 [0210] The therapeutic agent may be delivered with a device implanted in the eye. For example, the drug delivery device can be implanted at least partially within the sclera of the eye, so as to couple the drug delivery device to the sclera of the eye for the extended period of time. The therapeutic device may comprise a drug and a binding agent. The drug and binding agent can be configured to provide the sustained release for the extended time. A membrane or other diffusion barrier or mechanism may be a component of the therapeutic device to  
10 release the drug for the extended time.

[0211] The lifetime of the therapeutic device and number of injections can be optimized for patient treatment. For example, the device may remain in place for a lifetime of 30 years, for example with AMD patients from about 10 to 15 years. For example, the device may be configured for an implantation duration of at least two years, with 8 injections (once every  
15 three months) for sustained release of the therapeutic agent over the two year duration. The device may be configured for implantation of at least 10 years with 40 injections (once every three months) for sustained release of the therapeutic agent.

[0212] The therapeutic device can be refilled in many ways. For example, the therapeutic agent can be refilled into the device in the physician's office.

20 [0213] The therapeutic device may comprise many configurations and physical attributes, for example the physical characteristics of the therapeutic device may comprise at least one of a drug delivery device with a suture, positioning and sizing such that vision is not impaired, and biocompatible material. The device may comprise a reservoir capacity from about 0.005 cc to about 0.2 cc, for example from about 0.01 cc to about 0.1 cc, and a device volume of no more  
25 than about 2 cc. A vitrectomy may be performed for device volumes larger than 0.1 cc. The length of the device may not interfere with the patient's vision and can be dependent on the shape of the device, as well as the location of the implanted device with respect to the eye. The length of the device may also depend on the angle in which the device is inserted. For example, a length of the device may comprise from about 4 to 6 mm. Since the diameter of the

eye is about 24 mm, a device extending no more than about 6 mm from the sclera into the vitreous may have a minimal effect on patient vision.

[0214] Embodiments may comprise many combinations of implanted drug delivery devices. The therapeutic device may comprise a drug and binding agent. The device may also comprise  
5 at least one of a membrane, an opening, a diffusion barrier, a diffusion mechanism so as to release therapeutic amounts of therapeutic agent for the extended time.

[0215] FIG. 1 shows an eye 10 suitable for incorporation of the therapeutic device. The eye has a cornea 12 and a lens 22 configured to form an image on the retina 26. The cornea can extend to a limbus 14 of the eye, and the limbus can connect to a sclera 24 of the eye. A  
10 conjunctiva 16 of the eye can be disposed over the sclera. The lens can accommodate to focus on an object seen by the patient. The eye has an iris 18 that may expand and contract in response to light. The eye also comprises a choroid 28 disposed the between the sclera 24 and the retina 26. The retina comprises the macula 32. The eye comprises a pars plana 25, which  
15 comprises an example of a region of the eye suitable for placement and retention, for example anchoring, of the therapeutic device 100 as described herein. The pars plana region may comprise sclera and conjunctiva disposed between the retina and cornea. The therapeutic device can be positioned so as to extend from the pars plana region into the vitreous humor 30 to release the therapeutic agent. The therapeutic agent can be released into the vitreous humor  
20 30, such that the therapeutic agent arrives at the retina and choroids for therapeutic effect on the macula. The vitreous humor of the eye comprises a liquid disposed between the lens and the retina. The vitreous humor may comprise convection currents to deliver the therapeutic agent to the macula.

[0216] FIG. 1A-1 shows a therapeutic device 100 implanted at least partially within the sclera 24 of the eye 10 as in FIG. 1. The therapeutic device may comprise a retention structure,  
25 for example a protrusion, to couple the device to the sclera. The therapeutic device may extend through the sclera into vitreous humor 30, such that the therapeutic device can release the therapeutic agent into the vitreous humor.

[0217] FIGS. 1A-1-1 and 1A-1-2 shows a therapeutic device 100 implanted under the conjunctiva 16 and extending through the sclera 24 to release a therapeutic agent 110 into  
30 vitreous humor 30 of the eye 10 so as to treat the retina of the eye. The therapeutic device 100



may comprise a retention structure 120 such as a smooth protrusion configured for placement along the sclera and under the conjunctiva, such that the conjunctiva can cover the therapeutic device and protect the therapeutic device 100. When the therapeutic agent 110 is inserted into the device 100, the conjunctiva may be lifted away, incised, or punctured with a needle to  
5 access the therapeutic device. The eye may comprise an insertion of the tendon 27 of the superior rectus muscle to couple the sclera of the eye to the superior rectus muscle. The device 100 may be positioned in many locations of the pars plana region, for example away from tendon 27 and one or more of posterior to the tendon, posterior to the tendon, under the tendon, or with nasal or temporal placement of the therapeutic device.

10 **[0218]** While the implant can be positioned in the eye in many ways, work in relation to embodiments suggests that placement in the pars plana region can release therapeutic agent into the vitreous to treat the retina, for example therapeutic agent comprising an active ingredient composed of large molecules.

**[0219]** Therapeutic agents 110 suitable for use with device 100 includes many therapeutic  
15 agents, for example as listed in Table 1A, herein below. The therapeutic agent 110 of device 100 may comprise one or more of an active ingredient of the therapeutic agent, a formulation of the therapeutic agent, a commercially available formulation of the therapeutic agent, a physician prepared formulation of therapeutic agent, a pharmacist prepared formulation of the therapeutic agent, or a commercially available formulation of therapeutic agent having an  
20 excipient. The therapeutic agent may be referred to with generic name or a trade name, for example as shown in Table 1A.

**[0220]** The therapeutic device 100 can be implanted in the eye to treat the eye for as long as is helpful and beneficial to the patient. For example the device can be implanted for at least about 5 years, such as permanently for the life of the patient. Alternatively or in combination,  
25 the device can be removed when no longer helpful or beneficial for treatment of the patient.

**[0221]** FIG. 1A-2 shows structures of therapeutic device 100 configured for placement in an eye as in FIGS. 1A-1, 1A-1-1 and 1A-1-2. The device may comprise retention structure 120 to couple the device 100 to the sclera, for example a protrusion disposed on a proximal end of the device. The device 100 may comprise a container 130 affixed to the retention structure 120.  
30 An active ingredient, for example therapeutic agent 110, can be contained within a reservoir

140, for example a chamber 132 defined by a container 130 of the device. The container 130 may comprise a porous structure 150 comprising a porous material 152, for example a porous glass frit 154, and a barrier 160 to inhibit release of the therapeutic agent, for example non-permeable membrane 162. The non-permeable membrane 162 may comprise a substantially  
5 non-permeable material 164. The non-permeable membrane 162 may comprise an opening 166 sized to release therapeutic amounts of the therapeutic agent 110 for the extended time. The porous structure 150 may comprise a thickness 150T and pore sizes configured in conjunction with the opening 166 so as to release therapeutic amounts of the therapeutic agent for the extended time. The container 130 may comprise reservoir 140 having a chamber with a  
10 volume 142 sized to contain a therapeutic quantity of the therapeutic agent 110 for release over the extended time. The device may comprise a needle stop 170. Proteins in the vitreous humor may enter the device and compete for adsorption sites on the porous structure and thereby may contribute to the release of therapeutic agent. The therapeutic agent 110 contained in the reservoir 140 can equilibrate with proteins in the vitreous humor, such that the system is driven  
15 towards equilibrium and the therapeutic agent 110 is released in therapeutic amounts.

[0222] The non-permeable membrane 162, the porous material 152, the reservoir 140, and the retention structure 120, may comprise many configurations to deliver the therapeutic agent 110. The non-permeable membrane 162 may comprise an annular tube joined by a disc having at least one opening formed thereon to release the therapeutic agent. The porous material 152  
20 may comprise an annular porous glass frit 154 and a circular end disposed thereon. The reservoir 140 may be shape-changing for ease of insertion, i.e. it may assume a thin elongated shape during insertion through the sclera and then assume an extended, ballooned shape, once it is filled with therapeutic agent.

[0223] The porous structure 150 can be configured in many ways to release the therapeutic  
25 agent in accordance with an intended release profile. For example, the porous structure may comprise a porous structure having a plurality of openings on a first side facing the reservoir and a plurality of openings on a second side facing the vitreous humor, with a plurality of interconnecting channels disposed there between so as to couple the openings of the first side with the openings of the second side, for example a sintered rigid material. The porous  
30 structure 150 may comprise one or more of a permeable membrane, a semi-permeable

membrane, a material having at least one hole disposed therein, nano-channels, nano-channels etched in a rigid material, laser etched nano-channels, a capillary channel, a plurality of capillary channels, one or more tortuous channels, tortuous microchannels, sintered nanoparticles, an open cell foam or a hydrogel such as an open cell hydrogel.

5 [0224] FIG. 1A-2-1 shows therapeutic device 100 loaded into an insertion cannula 210 of an insertion apparatus 200, in which the device 100 comprises an elongate narrow shape for insertion into the sclera, and in which the device is configured to expand to a second elongate wide shape for retention at least partially in the sclera;

[0225] FIG. 1A-2-2 shows a therapeutic device 100 comprising reservoir 140 suitable for  
10 loading in a cannula, in which the reservoir 140 comprises an expanded configuration.

[0226] FIG. 1B shows therapeutic device 100 configured for placement in an eye as in FIG. 1A-1 and 1A-1-1. The device comprises retention structure 120 to couple to the sclera, for example flush with the sclera, and the barrier 160 comprises a tube 168. An active ingredient 112 comprising the therapeutic agent 110 is contained within tube 168 comprising non-  
15 permeable material 164. A porous material 152 is disposed at the distal end of the tube 168 to provide a sustained release of the therapeutic agent at therapeutic concentrations for the extended period. The non-permeable material 164 may extend distally around the porous material 152 so as to define an opening to couple the porous material 152 to the vitreous humor when the device is inserted into the eye.

20 [0227] The tube 168 and retention structure 120 may be configured to receive a glass rod, which is surface treated, and the glass rod can be injected with therapeutic agent . When the therapeutic agent has finished elution for the extended time, the rod can be replaced with a new rod.

[0228] The device 100 may comprise therapeutic agent and a carrier, for example a binding  
25 medium comprising a binding agent to deliver the therapeutic agent. The therapeutic agent can be surrounded with a column comprising a solid support that is eroded away.

[0229] FIG. 1C shows a therapeutic device configured for placement in an eye as in FIG. 1A-1 and 1A-1-1. A binding medium 192 comprising a binding agent 190 such as glass wool may be loaded with therapeutic agent 110 prior to injection into the device through an access port

180. The device 100 may comprise binding, leak, and barrier functions to deliver the therapeutic agent for the extended time. The binding medium 192 and therapeutic agent 110 can be aspirated to replace the binding medium and therapeutic agent. The binding medium can be at least one of flushed or replaced when at least majority of the therapeutic agent has been released, such that additional therapeutic agent can be delivered from a second, injected binding medium comprising therapeutic agent. A membrane 195 can be disposed over the periphery of the therapeutic device 100. The membrane 195 may comprise methylcellulose, regenerated cellulose, cellulose acetate, nylon, polycarbonate, poly(tetrafluoroethylene) (PTFE), polyethersulfone, and polyvinylidene difluoride (PVDF). The therapeutic device may comprise barrier 160 shaped such that opening 166 comprises an exit port. The therapeutic agent may be released through at least one of a diffusion mechanism or convection mechanism. The number, size, and configuration of exit ports may determine the release rate of the therapeutic agent. The exit port may comprise a convection port, for example at least one of an osmotically driven convection port or a spring driven convection port. The exit port may also comprise a tubular path to which the therapeutic agent may temporarily attach, and then be released under certain physical or chemical conditions.

[0230] FIG. 1C-A shows at least one exit port 167, the exit port can be disposed on the device 100 to allow liquid to flow from inside the device outward, for example when fluid is injected into an injection port 182 of the device or when an insert such as a glass frit is inserted into the device. The therapeutic device may comprise an access port 180 for injection and/or removal, for example a septum. Additionally or in the alternative, when the therapeutic device is refilled, the contents of the device may be flushed into the vitreous of the eye.

[0231] FIG. 1C-1 shows a method of removing a binding agent 194. A needle 189 coupled to a syringe 188 of an injector 187 can be inserted into an access port 180 of the therapeutic device 100. The binding agent 194 can be aspirated with a needle.

[0232] FIG. 1C-2 shows a method of inserting the therapeutic agent 110 with a second binding agent 190 having the therapeutic agent 110 bound thereon. The therapeutic agent can be injected into a container 130 of the device for sustained release over the extended time.

[0233] FIG. 1C-3 shows syringe being filled with a formulation of therapeutic agent for injection into the therapeutic device. The needle 189 coupled to syringe 188 of injector 187

can be used to draw therapeutic agent 110 from a container 110C. The container 110C may comprise a commercially available container, such as a bottle with a septum, a single dose container, or a container suitable for mixing formulations. A quantity 110V of therapeutic agent 110 can be drawn into injector 187 for injection into the therapeutic device 100

5 positioned within the eye. The quantity 110V may comprise a predetermined quantity, for example based on the volume of the container of the therapeutic device 110 and an intended injection into the vitreous humor. The example the quantity 110V may exceed the volume of the container so as to inject a first portion of quantity 110V into the vitreous humor through the therapeutic device and to contain a second portion of quantity 110V within the container of the  
10 therapeutic device 110. Container 110C may comprise a formulation 110F of the therapeutic agent 110. The formulation 110F may comprise a commercially available formulations of therapeutic agent, for example therapeutic agents as described herein and with reference to Table 1A. Non-limiting examples of commercially available formulations that may be suitable for use in accordance with the embodiments described herein include Lucentis<sup>TM</sup> and  
15 Triamcinolone, for example. The formulation 110F may be a concentrated or diluted formulation of a commercially available therapeutic agent, for example Avastin<sup>TM</sup>. The osmolarity and tonicity of the vitreous humor can be within a range from about 290 to about 320. For example, a commercially available formulation of Avastin<sup>TM</sup> may be diluted so as to comprise a formulation having an osmolarity and tonicity substantially similar to the osmolarity  
20 and tonicity of the vitreous humor, for example within a range from about 280 to about 340, for example about 300 mOsm. While the therapeutic agent 110 may comprise an osmolarity and tonicity substantially similar to the vitreous humor, the therapeutic agent 110 may comprise a hyper osmotic solution relative to the vitreous humor or a hypo osmotic solution relative to the vitreous humor. A person of ordinary skill in the art can conduct experiments based on the  
25 teachings described herein so as to determine empirically the formulation and osmolarity of the therapeutic agent to provide release of therapeutic agent for an extended time.

[0234] For example, in the United States of America, Lucentis<sup>TM</sup> (active ingredient ranibizumab) is supplied as a preservative-free, sterile solution in a single-use glass vial designed to deliver 0.05 mL of 10 mg/mL Lucentis<sup>TM</sup> aqueous solution with 10 mM histidine  
30 HCl, 10%  $\alpha$ ,  $\alpha$ -trehalose dihydrate, 0.01% polysorbate 20, at pH 5.5. In Europe, the Lucentis<sup>TM</sup> formulation can be substantially similar to the formulation of the United States.

[0235] For example, the sustained release formulation of Lucentis™ in development by Genentech and/or Novartis, may comprise the therapeutic agent injected in to the device 100. The sustained release formulation may comprise particles comprising active ingredient.

5 [0236] For example, in the United States, Avastin™ (bevacizumab) is approved as an anticancer drug and in clinical trials are ongoing for AMD. For cancer, the commercial solution is a pH 6.2 solution for intravenous infusion. Avastin™ is supplied in 100 mg and 400 mg preservative-free, single-use vials to deliver 4 mL or 16 mL of Avastin™ (25 mg/mL). The 100 mg product is formulated in 240 mg  $\alpha,\alpha$ -trehalose dihydrate, 23.2 mg sodium phosphate (monobasic, monohydrate), 4.8 mg sodium phosphate (dibasic, anhydrous), 1.6 mg polysorbate  
10 20, and Water for Injection, USP. The 400 mg product is formulated in 960 mg  $\alpha,\alpha$ -trehalose dihydrate, 92.8 mg sodium phosphate (monobasic, monohydrate), 19.2 mg sodium phosphate (dibasic, anhydrous), 6.4 mg polysorbate 20, and Water for Injection, USP. The commercial formulations are diluted in 100mL of 0.9% sodium chloride before administration and the amount of the commercial formulation used varies by patient and indication. Based on the  
15 teachings described herein, a person of ordinary skill in the art can determine formulations of Avastin™ to inject into therapeutic device 100. In Europe, the Avastin™ formulation can be substantially similar to the formulation of the United States.

[0237] For example, in the United States, there are 2 forms of Triamcinolone used in injectable solutions, the acetonide and the hexacetonide. The acetamide is approved for  
20 intravitreal injections in the U.S. The acetamide is the active ingredient in TRIVARIS (Allergan), 8 mg triamcinolone acetonide in 0.1 mL (8% suspension) in a vehicle containing w/w percents of 2.3% sodium hyaluronate; 0.63% sodium chloride; 0.3% sodium phosphate, dibasic; 0.04% sodium phosphate, monobasic; and water, pH 7.0 to 7.4 for injection. The acetamide is also the active ingredient in Triesence™ (Alcon), a 40mg/ml suspension.

25 [0238] A person of ordinary skill in the art can determine the osmolarity for the formulations as described herein. The degree of dissociation of the active ingredient in solution can be determined and used to determined differences of osmolarity from the molarity in these formulations. For example, considering at least some of the formulations may be concentrated (or suspensions), the molarity can differ from the osmolarity.

[0239] The formulation of therapeutic agent may injected into therapeutic device 100 may comprise many known formulations of therapeutic agents, and the formulation therapeutic agent comprises an osmolatiry suitable for release for an extended time from device 100. Table 1B shows examples of osmolarity (Osm) of saline and some of the commercially formulations of Table 1A.

[0240] Table 1B.

**Summary of Calculations**

Description	Osm (M)
Saline (0.9%)	0.308
Phosphate Buffered Saline (PBS)	0.313
Lucentis <sup>TM</sup>	0.289
Avastin <sup>TM</sup>	0.182
Triamcinolone Acetonide (Trivaris-Allergan)	0.342
Triamcinolone Acetonide (Triessence - Alcon)	Isotonic*
Triamcinolone Acetonide (Kenalog - Apotthecon)	Isotonic*

\*As described in package insert

[0241] The vitreous humor of the eye comprises an osmolarity of about 290 mOsm to about 320 mOsm. Formulations of therapeutic agent having an osmolarity from about 280 mOsm to about 340 mOsm are substantially isotonic and substantially iso-osmotic with respect to the vitreous humor of the eye. Although the formulations listed in Table 1B are substantially iso-osmotic and isotonic with respect to the vitreous of the eye and suitable for injection into the therapeutic device, the formulation of the therapeutic agent injected into the therapeutic device can be hypertonic (hyper-osmotic) or hypotonic (hypo-osmotic) with respect to the tonicity and osmolarity of the vitreous. Work in relation to embodiments suggests that a hyper-osmotic formulation may release the active ingredient of the therapeutic agent into the vitreous somewhat faster initially when the solutes of the injected formulation equilibrate with the osmolatiry of the vitreous, and that a hypo-osmotic formulation such as Avastin<sup>TM</sup> may release the active ingredient of the therapeutic agent into the vitreous somewhat slower initially when the solutes of the injected formulation equilibrate with the eye. A person of ordinary skill in the art can conduct experiments based on the teaching described herein to determine empirically the appropriate reservoir chamber volume and porous structure for a formulation of therapeutic agent disposed in the reservoir chamber, so as to release therapeutic amounts of the

therapeutic agent for an extended time and to provide therapeutic concentrations of therapeutic agent in the vitreous within a range of therapeutic concentrations that is above the minimum inhibitory concentration for the extended time.

5 [0242] The therapeutic device may comprise at least one structure configured to provide safety precautions. The device may comprise at least one structure to prevent at least one of macrophage or other immune cell within the reservoir body; bacterial penetration; or retinal detachment.

10 [0243] The therapeutic device may be configured for other applications in the body. Other routes of administration of drugs may include at least one of intraocular, oral, subcutaneous, intramuscular, intraperitoneal, intranasal, dermal, intrathecal, intravascular, intra articular, pericardial, intraluminal in organs and gut or the like.

15 [0244] Conditions that may be treated and/or prevented using the drug delivery device and method described herein may include at least one of the following: hemophilia and other blood disorders, growth disorders, diabetes, leukemia, hepatitis, renal failure, HIV infection, hereditary diseases such as cerebrosidase deficiency and adenosine deaminase deficiency, hypertension, septic shock, autoimmune diseases such as multiple sclerosis, Graves disease, systemic lupus erythematosus and rheumatoid arthritis, shock and wasting disorders, cystic fibrosis, lactose intolerance, Crohn's disease, inflammatory bowel disease, gastrointestinal or other cancers, degenerative diseases, trauma, multiple systemic conditions such as anemia, and  
20 ocular diseases such as, for example, retinal detachment, proliferative retinopathy, proliferative diabetic retinopathy, degenerative disease, vascular diseases, occlusions, infection caused by penetrating traumatic injury, endophthalmitis such as endogenous/systemic infection, post-operative infections, inflammations such as posterior uveitis, retinitis or choroiditis and tumors such as neoplasms and retinoblastoma.

25 [0245] Examples of therapeutic agents 110 that may be delivered by the therapeutic device 100 are described in Table 1A and may include Triamcinolone acetonide, Bimatoprost (Lumigan), Ranibizumab (Lucentis<sup>TM</sup>), Travoprost (Travatan, Alcon), Timolol (Timoptic, Merck), Levobunolol (Betagan, Allergan), Brimonidine (Alphagan, Allergan), Dorzolamide (Trusopt, Merck), Brinzolamide (Azopt, Alcon). Additional examples of therapeutic agents  
30 that may be delivered by the therapeutic device include antibiotics such as tetracycline,



chlortetracycline, bacitracin, neomycin, polymyxin, gramicidin, cephalixin, oxytetracycline, chloramphenicol kanamycin, rifampicin, ciprofloxacin, tobramycin, gentamycin, erythromycin and penicillin; antifungals such as amphotericin B and miconazole; anti-bacterials such as sulfonamides, sulfadiazine, sulfacetamide, sulfamethizole and sulfisoxazole, nitrofurazone and sodium propionate; antivirals such as idoxuridine, trifluorotymidine, acyclovir, ganciclovir and interferon; antiallergenics such as sodium cromoglycate, antazoline, methapyriline, chlorpheniramine, pyrillamine, cetirizine and prophenpyridamine; anti-inflammatories such as hydrocortisone, hydrocortisone acetate, dexamethasone, dexamethasone 21-phosphate, fluocinolone, medrysone, prednisolone, prednisolone 21-phosphate, prednisolone acetate, fluoromethalone, betamethasone, and triamcinolone; non-steroidal anti-inflammatories such as salicylate, indomethacin, ibuprofen, diclofenac, flurbiprofen and piroxicam; decongestants such as phenylephrine, naphazoline and tetrahydrozoline; miotics and anticholinesterases such as pilocarpine, salicylate, acetylcholine chloride, physostigmine, eserine, carbachol, diisopropyl fluorophosphate, phospholine iodide and demecarium bromide; mydriatics such as atropine sulfate, cyclopentolate, homatropine, scopolamine, tropicamide, eucatropine and hydroxyamphetamine; sympathomimetics such as epinephrine; antineoplastics such as carmustine, cisplatin and fluorouracil; immunological drugs such as vaccines and immune stimulants; hormonal agents such as estrogens, estradiol, progestational, progesterone, insulin, calcitonin, parathyroid hormone and peptide and vasopressin hypothalamus releasing factor; beta adrenergic blockers such as timolol maleate, levobunolol Hcl and betaxolol Hcl; growth factors such as epidermal growth factor, fibroblast growth factor, platelet derived growth factor, transforming growth factor beta, somatotropin and fibronectin; carbonic anhydrase inhibitors such as dichlorophenamide, acetazolamide and methazolamide and other drugs such as prostaglandins, antiprostaglandins and prostaglandin precursors. Other therapeutic agents known to those skilled in the art which are capable of controlled, sustained release into the eye in the manner described herein are also suitable for use in accordance with embodiments of the present invention.

**[0246]** The therapeutic agent 110 may comprise one or more of the following: Abarelix, Abatacept, Abciximab, Adalimumab, Aldesleukin, Alefacept, Alemtuzumab, Alpha-1-proteinase inhibitor, Alteplase, Anakinra, Anistreplase, Antihemophilic Factor, Antithymocyte globulin, Aprotinin, Arcitumomab, Asparaginase, Basiliximab, Becaplermin, Bevacizumab,

Bivalirudin, Botulinum Toxin Type A, Botulinum Toxin Type B, Capromab, Cetorelix, Cetuximab, Choriogonadotropin alfa, Coagulation Factor IX, Coagulation factor VIIa, Collagenase, Corticotropin, Cosyntropin, Cyclosporine, Daclizumab, Darbepoetin alfa, Defibrotide, Denileukin diftitox, Desmopressin, Dornase Alfa, Drotrecogin alfa, Eculizumab, 5 Efalizumab, Enfuvirtide, Epoetin alfa, Eptifibatide, Etanercept, Exenatide, Felypressin, Filgrastim, Follitropin beta, Galsulfase, Gemtuzumab ozogamicin, Glatiramer Acetate, Glucagon recombinant, Goserelin, Human Serum Albumin, Hyaluronidase, Ibritumomab, Idursulfase, Immune globulin, Infliximab, Insulin Glargine recombinant, Insulin Lyspro recombinant, Insulin recombinant, Insulin, porcine, Interferon Alfa-2a, Recombinant, 10 Interferon Alfa-2b, Recombinant, Interferon alfacon-1, Interferon alfa-n1, Interferon alfa-n3, Interferon beta-1b, Interferon gamma-1b, Lepirudin, Leuprolide, Lutropin alfa, Mecasermin, Menotropins, Muromonab, Natalizumab, Nesiritide, Octreotide, Omalizumab, Oprelvekin, OspA lipoprotein, Oxytocin, Palifermin, Palivizumab, Panitumumab, Pegademase bovine, Pegaptanib, Pegaspargase, Pegfilgrastim, Peginterferon alfa-2a, Peginterferon alfa-2b, 15 Pegvisomant, Pramlintide, Ranibizumab, Rasburicase, Reteplase, Rituximab, Salmon Calcitonin, Sargramostim, Secretin, Sermorelin, Serum albumin iodinated, Somatropin recombinant, Streptokinase, Tenecteplase, Teriparatide, Thyrotropin Alfa, Tositumomab, Trastuzumab, Urofollitropin, Urokinase, or Vasopressin. The molecular weights of the molecules and indications of these therapeutic agents are set for below in Table 1A, below.

20 **[0247]** The therapeutic agent 110 may comprise one or more of compounds that act by binding members of the immunophilin family of cellular proteins. Such compounds are known as "immunophilin binding compounds." Immunophilin binding compounds include but are not limited to the "limus" family of compounds. Examples of limus compounds that may be used include but are not limited to cyclophilins and FK506-binding proteins (FKBPs), including 25 sirolimus (rapamycin) and its water soluble analog SDZ-RAD, tacrolimus, everolimus, pimecrolimus, CCI-779 (Wyeth), AP23841 (Ariad), and ABT-578 (Abbott Laboratories).

**[0248]** The limus family of compounds may be used in the compositions, devices and methods for the treatment, prevention, inhibition, delaying the onset of, or causing the regression of angiogenesis-mediated diseases and conditions of the eye, including choroidal 30 neovascularization. The limus family of compounds may be used to prevent, treat, inhibit,

delay the onset of, or cause regression of AMD, including wet AMD. Rapamycin may be used to prevent, treat, inhibit, delay the onset of, or cause regression of angiogenesis-mediated diseases and conditions of the eye, including choroidal neovascularization. Rapamycin may be used to prevent, treat, inhibit, delay the onset of, or cause regression of AMD, including wet  
5 AMD.

[0249] The therapeutic agent 110 may comprise one or more of: pyrrolidine, dithiocarbamate (NF.kappa.B inhibitor); squalamine; TPN 470 analogue and fumagillin; PKC (protein kinase C) inhibitors; Tie-1 and Tie-2 kinase inhibitors; inhibitors of VEGF receptor kinase; proteasome inhibitors such as Velcade.TM. (bortezomib, for injection; ranibuzumab (Lucentis.TM.) and  
10 other antibodies directed to the same target; pegaptanib (Macugen.TM.); vitronectin receptor antagonists, such as cyclic peptide antagonists of vitronectin receptor-type integrins; .alpha.-v/.beta.-3 integrin antagonists; .alpha.-v/.beta.-1 integrin antagonists; thiazolidinediones such as rosiglitazone or troglitazone; interferon, including .gamma.-interferon or interferon targeted to CNV by use of dextran and metal coordination; pigment epithelium derived factor (PEDF);  
15 endostatin; angiostatin; tumistatin; canstatin; anecortave acetate; acetamide; triamcinolone; tetrathiomolybdate; RNA silencing or RNA interference (RNAi) of angiogenic factors, including ribozymes that target VEGF expression; Accutane.TM. (13-cis retinoic acid); ACE inhibitors, including but not limited to quinopril, captopril, and perindozril; inhibitors of mTOR (mammalian target of rapamycin); 3-aminothalidomide; pentoxifylline; 2-methoxyestradiol;  
20 colchicines; AMG-1470; cyclooxygenase inhibitors such as nepafenac, rofecoxib, diclofenac, rofecoxib, NS398, celecoxib, vioxx, and (E)-2-alkyl-2(4-methanesulfonylphenyl)-1-phenylethene; t-RNA synthase modulator; metalloprotease 13 inhibitor; acetylcholinesterase inhibitor; potassium channel blockers; endorepellin; purine analog of 6-thioguanine; cyclic peroxide ANO-2; (recombinant) arginine deiminase; epigallocatechin-3-gallate; cerivastatin;  
25 analogues of suramin; VEGF trap molecules; apoptosis inhibiting agents; Visudyne.TM., snET2 and other photo sensitizers, which may be used with photodynamic therapy (PDT); inhibitors of hepatocyte growth factor (antibodies to the growth factor or its receptors, small molecular inhibitors of the c-met tyrosine kinase, truncated versions of HGF e.g. NK4).

[0250] The therapeutic agent 110 may comprise a combination with other therapeutic agents  
30 and therapies, including but not limited to agents and therapies useful for the treatment of

angiogenesis or neovascularization, particularly CNV. Non-limiting examples of such additional agents and therapies include pyrrolidine, dithiocarbamate (NF.kappa.B inhibitor); squalamine; TPN 470 analogue and fumagillin; PKC (protein kinase C) inhibitors; Tie-1 and Tie-2 kinase inhibitors; inhibitors of VEGF receptor kinase; proteasome inhibitors such as  
5 Velcade.TM. (bortezomib, for injection; ranibuzumab (Lucentis.TM.) and other antibodies directed to the same target; pegaptanib (Macugen.TM.); vitronectin receptor antagonists, such as cyclic peptide antagonists of vitronectin receptor-type integrins; .alpha.-v/.beta.-3 integrin antagonists; .alpha.-v/.beta.-1 integrin antagonists; thiazolidinediones such as rosiglitazone or troglitazone; interferon, including .gamma.-interferon or interferon targeted to CNV by use of  
10 dextran and metal coordination; pigment epithelium derived factor (PEDF); endostatin; angiostatin; tumistatin; canstatin; anecortave acetate; acetamide; triamcinolone; tetrathiomolybdate; RNA silencing or RNA interference (RNAi) of angiogenic factors, including ribozymes that target VEGF expression; Accutane.TM. (13-cis retinoic acid); ACE inhibitors, including but not limited to quinopril, captopril, and perindozril; inhibitors of mTOR  
15 (mammalian target of rapamycin); 3-aminothalidomide; pentoxifylline; 2-methoxyestradiol; colchicines; AMG-1470; cyclooxygenase inhibitors such as nepafenac, rofecoxib, diclofenac, rofecoxib, NS398, celecoxib, vioxx, and (E)-2-alkyl-2(4-methanesulfonylphenyl)-1-phenylethane; t-RNA synthase modulator; metalloprotease 13 inhibitor; acetylcholinesterase inhibitor; potassium channel blockers; endorepellin; purine analog of 6-thioguanine; cyclic  
20 peroxide ANO-2; (recombinant) arginine deiminase; epigallocatechin-3-gallate; cerivastatin; analogues of suramin; VEGF trap molecules; inhibitors of hepatocyte growth factor (antibodies to the growth factor or its receptors, small molecular inhibitors of the c-met tyrosine kinase, truncated versions of HGF e.g. NK4); apoptosis inhibiting agents; Visudyne.TM., snET2 and other photo sensitizers with photodynamic therapy (PDT); and laser photocoagulation.

25 **[0251]** The therapeutic agents may be used in conjunction with a pharmaceutically acceptable carrier such as, for example, solids such as starch, gelatin, sugars, natural gums such as acacia, sodium alginate and carboxymethyl cellulose; polymers such as silicone rubber; liquids such as sterile water, saline, dextrose, dextrose in water or saline; condensation products of castor oil and ethylene oxide, liquid glyceryl triester of a lower molecular weight fatty acid; lower  
30 alkanols; oils such as corn oil, peanut oil, sesame oil, castor oil, and the like, with emulsifiers such as mono- or di-glyceride of a fatty acid, or a phosphatide such as lecithin, polysorbate 80,

and the like; glycols and polyalkylene glycols; aqueous media in the presence of a suspending agent, for example, sodium carboxymethylcellulose, sodium hyaluronate, sodium alginate, poly(vinyl pyrrolidone) and similar compounds, either alone, or with suitable dispensing agents such as lecithin, polyoxyethylene stearate and the like. The carrier may also contain adjuvants  
5 such as preserving, stabilizing, wetting, emulsifying agents or other related materials.

[0252] The therapeutic device may comprise a container configured to hold at least one therapeutic agent, the container comprising a chamber to hold the at least one therapeutic agent with at least one opening to release the at least one therapeutic agent to the vitreous humor and porous structure 150 placed within the at least one opening. The porous structure 150 may  
10 comprise a fixed tortuous, porous material such as a sintered metal, a sintered glass or a sintered polymer with a defined porosity and tortuosity that controls the rate of delivery of the at least one therapeutic agent to the vitreous humor. The rigid porous structures provide certain advantages over capillary tubes, erodible polymers and membranes as a mechanism for  
15 controlling the release of a therapeutic agent or agents from the therapeutic device. These advantages include the ability of the rigid porous structure to comprise a needle stop, simpler and more cost effective manufacture, flushability for cleaning or declogging either prior to or after implantation, high efficiency depth filtration of microorganisms provided by the  
20 labyrinths of irregular paths within the structure and greater robustness due to greater hardness and thickness of the structure compared to a membrane or erodible polymer matrix. Additionally, when the rigid porous structure is manufactured from a sintered metal, ceramic,  
25 glass or certain plastics, it can be subjected to sterilization and cleaning procedures, such as heat or radiation based sterilization and depyrogenation, that might damage polymer and other membranes. In certain embodiments, as illustrated in example 9, the rigid porous structure may be configured to provide a therapeutically effective, concentration of the therapeutic agent in  
the vitreous for at least 6 months. This release profile provided by certain configurations of the rigid porous structures enables a smaller device which can be preferred in a small organ such as the eye where larger devices may alter or impair vision.

[0253] TUNING OF THERAPEUTIC DEVICE FOR SUSTAINED RELEASE BASED ON AN INJECTION OF A FORMULATION

[0254] The therapeutic device 100 can be tuned to deliver a target therapeutic concentration profile based on the volume of formulation injected into the device, for example as described in U.S. Pat. App. Ser. No. 12/696,678, Pub. No. 2010/0255061, the full disclosure of which has been previously incorporated by reference. The injected volume may comprise a substantially fixed volume, for example within about +/-30% of an intended pre-determined target volume. The volume of the reservoir can be sized with the release rate index so as to release the therapeutic agent for an extended time substantially greater than the treatment time of a corresponding bolus injection. The device can also be tuned to release the therapeutic agent based on the half life of the therapeutic agent in the eye. The device volume and release rate index comprise parameters that can be tuned together based on the volume of formulation injected and the half life of the therapeutic agent in the eye. The following equations can be used to determine therapeutic device parameters suitable for tuning the device.

$$\text{Rate} = V_r(dC_r/dt) = -D(PA/TL)C_r$$

where Rate = Rate of release of therapeutic agent from device

Cr = concentration of therapeutic agent in reservoir

V<sub>r</sub> = volume of reservoir

D = Diffusion constant

PA/TL = RRI

P = porosity

A = area

T = tortuosity = F = channel parameter.

For a substantially fixed volume injection,

$$C_{r0} = (\text{Injection Volume})(\text{Concentration of Formulation})/V_r$$

Where C<sub>r0</sub> = initial concentration in reservoir following injection of formulation

For Injection Volume = 50 uL

$$C_{r0} = (0.05 \text{ mL})(10 \text{ mg/mL})/V_r (1000 \text{ ug/ 1 mg}) = 500 \text{ ug} / V_r$$

$$\text{Rate} = x(500 \text{ ug})\exp(-xt)$$

where  $t = \text{time}$

$$x = (D/V_r)(PA/TL)$$

With a mass balance on the vitreous

$$5 \quad V_v(dC_v/dt) = \text{Rate from device} = kV_vC_v$$

where  $V_v = \text{volume of vitreous (about 4.5 ml)}$

$C_v = \text{concentration of therapeutic agent in vitreous}$

$k = \text{rate of drug from vitreous ( proportional to } 1 / \text{ half life of drug in vitreous)}$

10 For the situation appropriate for the embodiments as described herein where  $C_v$  remains substantially constant and changes slowly with time (i.e.  $dC_v/dt$  is approximately 0),

$$C_v = (\text{Rate from device})/(kV_v)$$

15 Since  $kV_v$  is substantially constant, the max value of  $C_v$  will correspond to conditions that maximize the Rate from the device. At a given time since injection into the device (e.g., 180 days), the maximum  $C_v$  is found at the the value of  $x$  that provides the maximum rate. The optimal value of  $x$  satisfies

$$d(\text{Rate})/dx = 0 \text{ at a given time.}$$

$$\text{Rate} = 500(x)\exp(-xt) = f(x)g(x) \text{ where } f(x)=500x \text{ and } g(x) = \exp(-xt)$$

$$d(\text{Rate})/dx = f'(x)g(x) + f(x)g'(x) = 500(1-xt)\exp(-xt)$$

$$\text{For a given time, } t, d(\text{Rate})/dx = 0 \text{ when } 1-xt = 0 \text{ and } xt = 1$$

20 The rate is maximum when  $(D/V_r)(PA/TL)t = 1$ .

$$\text{For a given volume, optimal } PA/TL = \text{optimal RRI} = V_r/(Dt)$$

Therefore the highest  $C_v$  at a given time,  $t$ , occurs for the optimal RRI =  $(PA/FL)$  for a given  $V_r$ .

Also, the ratio  $(V_r)/(RRI) = (V_r)/(PA/TL) = Dt$  will determine the optimal rate at the time.

[0255] The above equations provide approximate optimized values that, when combined with numerical simulations, can provide optimal values of  $V_r$  and  $PA/TL$ . The final optimum value can depend on additional parameters, such as the filling efficiency.

[0256] The above parameters can be used to determine the optimal RRI, and the therapeutic device can be tuned to the volume of formulation injected into the device with a device reservoir volume and release rate index within about +/- 50% of the optimal values, for example +/- 30% of the optimal values. For example, for an optimal release rate index of the porous structure and an optimal reservoir volume sized to receive a predetermined quantity of therapeutic agent, e.g. 50 uL, so as to achieve therapeutic concentrations above a minimum inhibitory concentration for a predetermined extended time such as 90 days, the maximum volume of the reservoir can be limited to no more than about twice the optimal volume. This tuning of the reservoir volume and the porous structure to the injected volume of the commercially available formulation can increase the time of release of therapeutic amounts from the device as compared to a much larger reservoir volume that receives the same volume of commercially available injectable formulation. Although many examples as described herein show a porous frit structure and reservoir volume tuned together to receive a quantity of formulation and provide release for an extended time, the porous structure tuned with the reservoir may comprise one or more of a porous frit, a permeable membrane, a semi-permeable membrane, a capillary tube or a tortuous channel, nano-structures, nano-channels or sintered nano-particles, and a person of ordinary skill in the art can determine the release rate characteristics, for example a release rate index, so as to tune the one or more porous structures and the volume to receive the quantity of the formulation and release therapeutic amounts for an extended time.

[0257] As an example, the optimal RRI at 180 days can be determined for a reservoir volume of about 125 uL. Based on the above equations  $(V_r/Dt) = \text{optimal RRI}$ , such that the optimal RRI at 180 days is about 0.085 for the 50 uL formulation volume injected into the device. The corresponding  $C_v$  is about 3.19 ug/mL at 180 days based on the Rate of drug released from the device at 180 days and the rate of the drug from the vitreous ( $k$  corresponding to a half life of about 9 days). A device with a container reservoir volume of 63 uL and RRI of 0.044 will also provide the optimal  $C_v$  at 180 days since the ratio of  $V_r$  to  $PA/TL$  is also optimal. Although an



optimal value can be determined, the therapeutic device can be tuned to provide therapeutic amounts of drug at a targeted time, for example 180 days, with many values of the reservoir volume and many values of the release rate index near the optimal values, for example within about +/- 50% of the optimal values. Although the volume of the reservoir can be substantially  
5 fixed, the volume of the reservoir can vary, for example within about +/- 50% as with an expandable reservoir such as a balloon reservoir.

[0258] The half life of the drug in the vitreous humor of the eye can be determined based on the therapeutic agent and the type of eye, for example human, rabbit or monkey, such that the half life may be determined based on the species of the eye, for example. With at least some  
10 animal models the half life of the therapeutic agent in the vitreous humor can be shorter than for human eyes, for example by a factor of about two in at least some instances. For example, the half-life of the therapeutic agent Lucentis<sup>TM</sup> (ranibizumab) can be about nine days in the human eye and about two to four days in the rabbit and monkey animal models. For small molecules, the half life in the vitreous humor of the human eye can be about two to three hours  
15 and can be about one hour in the monkey and rabbit animal models. The therapeutic device can be tuned to receive the volume of formulation based on the half life of the therapeutic agent in the human vitreous humor, or an animal vitreous humor, or combinations thereof. Based on the teachings described herein, a person of ordinary skill in the art can determine empirically the half life of the therapeutic agent in the eye based on the type of eye and the therapeutic agent,  
20 such that the reservoir and porous structure can be tuned together so as to receive the volume of formulation and provide therapeutic amounts for the extended time.

#### [0259] COMBINED THERAPEUTIC AGENT TREATMENTS

[0260] The thereapeutic agents and devices as described herein can be used to deliver combinaitons of therapeutic agents for an extended time. The combined therapeutic agents can  
25 be used to treat many disease of the eye, for example age related macular degeneration (herainafter "AMD").

[0261] The embodiments as described herein may incorporate one or more components of the methods and apparatus described in U.S. App. Ser. No. 12/696,678, filed January 29, 2010, entitled "Posterior Segment Drug Delivery", U.S. Pat. App. Pub. No. 2010/0255061 (attorney

docket not. 026322-003750US), the full disclosure of which has been previously incorporated herein by reference.

[0262] As used herein, like numerals and letters denote like apparatus structures and like method steps, for example as combined with like structures and method steps of U.S. App. Ser. No. 12/696,678, in accordance with embodiments as described herein.

[0263] Combination therapy to treat AMD may be used to treat a patient through the different disease stages. Early in the AMD disease an inflammatory and oxidative stress takes a role in the development of the early and intermediate stage of the disease. When an advanced stage of AMD develops, the advanced stage may be enhanced by the VEGF activity and inflammatory components. When choroidal neovascularization (hereinafter "CNV") is under successful control of the treating physician there can be a benefit to controlling scar development and recurrence of the CNV (~50%) due to an ongoing inflammatory stress.

[0264] Combination therapy to treat AMD may comprise means for placing one or more of the sustained release therapeutic device 100 as described herein that can host various compounds either in combination or sequentially, or combinations thereof, based on the disease stage and targeted therapeutic treatment.

[0265] For example: A patient with early stage AMD who is at risk for advancing to intermediate or advanced AMD may benefit from an anti inflammatory treatment such as complement inhibitor alone or in combination with an anti oxidant. If the disease advances to CNV the same device may be injected with AntiVEGF alone or in combination with any anti-inflammatory agent. Subsequently when the CNV is under successful control an agent to control local inflammation such as COX inhibitor can be injected to the device to reduce the chances for fibrosis and recurrence.

[0266] Therapeutic agents to treat stages of AMD.

1. An AMD patient may go through few different disease stages, and one or more combinations of therapeutic devices or agents can be used to treat each stage of the disease. One or more corresponding therapeutic agent can be injected to treat neovascularization and inflammation, appropriate to the condition of the eye.
  - a. Early/Intermediate AMD - Mainly manifested by presence of Drusen (also referred to as dry AMD)
  - b. Advanced AMD (also referred to as wet AMD)
    - i. CNV

1. New CNV
2. CNV recurrence following successful treatment cycle
- ii. Geographic Atrophy
2. Inflammation may play a role in all these stages, and an anti-inflammatory treatment agent can be used at each stage
  - a. Genetic variability of the complement system may causes defective regulation of the complement system. Enhanced complement activity may increase inflammation which in turn increases VEGF expression and CNV development. The therapeutic agent injected into device 100 can be injected based on a response of the patient to treatment.
  - b. Complement factors have been found in both Drusen and CNV and can contribute to cell apoptosis.
  - c. An inflammatory component is present while CNV is regressing and may contribute to scar formation which can cause additional retinal damage. An antiinflammatory can be injected into to inhibit scar formation.
3. Oxidative stress may cause both early stage AMD and can be associated with the transformation of Intermediate to advanced AMD
4. Anti inflammatory agents having an effect on the wet stage of AMD and suitable for injection into therapeutic device 100 include one or more of:
  - a. Steroids
  - b. Tumor necrosis factor (hereinafter "TNF") inhibitors
  - c. COX inhibitors
5. Complement system inhibitors can be combined in accordance with embodiments described herein for the treatment of early, intermediate and advanced stages of AMD

[0267] The combination therapy to treat AMD may comprise one or more of injecting the therapeutic agent 110 directly into the vitreous humor from a needle, injecting the therapeutic agent into therapeutic device 100 to store the therapeutic agent in device 100, injecting the therapeutic agent into the device 100 and through a porous structure to deliver a bolus of therapeutic agent 110 and store therapeutic agent 110 in device 100, injecting a first therapeutic agent 110 into a first device 100 and a second therapeutic agent 110 into a second thereapeutic device 100. Below Table 2 shows combinations treatments in accordance with embodiments.

Table 2. Combinations of therapeutic agent injections and devices

Combination	First Therapeutic Agent: Vascularization Inhibitor (e.g VEGF Inhib)	Second Therapeutic agent: NSAID (e.g. Oxygenase Inhibitor)
1	Injected into Device 1 when implanted	Injected into Device 1 when implanted
2	Injected into Device 1 when implanted	Solid on inside of device when implanted

3	Injected into Device 1 when implanted	solid on outside of device when implanted
4	Injected into Device 1 when implanted	solid suspension injected into device first chamber of device when implanted
5	Injected into Device 1 when implanted	solid suspension injected into second chamber of device when implanted
6	Injected into Device 1 when implanted	Injected into Device 2 when implanted
7	Injected into Device 1 when implanted	Injected into Vitreous Humor
8	Injected into Vitreous Humor	Injected into Device 2
9	Injected into Vitreous Humor	Injected into Vitreous Humor

[0268] The combinations shown in Table 2 can be used in many ways to treat the patient.

[0269] Fig. 2 shows a first therapeutic agent 110A contained in a first injector 187 and a second therapeutic agent 110B contained in a second injector 187 to treat the patient. The first therapeutic agent 110A can be combined with the second therapeutic agent 110B to treat the eye. The first therapeutic agent 110A and the second therapeutic agent 110B can be injected into the vitreous humor of the eye. The first therapeutic agent 110A may comprise a therapeutic agent to inhibit neoplasia, for example to inhibit neovascularization such as a VEGF inhibitor. The second therapeutic agent 110B may comprise an antiinflammatory, for example a steroid or a non-steroidal antiinflammatory such as a COX inhibitor. While the first therapeutic agent and the second therapeutic agent can be delivered in many ways, the first therapeutic agent and the second therapeutic agent may each be injected directly into the vitreous humor with a needle of the injector.

[0270] Fig. 3 shows a first therapeutic agent 110A contained in a first injector 187 injected directly into the vitreous humor of the eye and a second therapeutic agent 110B contained in a second injector 187 injected into therapeutic device 100 so as to treat the patient. The therapeutic device can be configured to release first therapeutic agent 110A for an extended time as described herein. The first therapeutic agent may comprise the agent to inhibit neoplasia and the second therapeutic agent may comprise the antiinflammatory. Alternatively,

the second therapeutic agent may comprise the agent to inhibit neoplasia and the first therapeutic agent may comprise the antiinflammatory.

[0271] Fig. 4 shows a plurality of therapeutic devices implanted into the eye to deliver therapeutic amounts of first therapeutic agent 110A and second therapeutic agent 110B. The plurality of therapeutic devices comprises a first therapeutic device 100 and a second therapeutic device 100. The first therapeutic device 100 can be configured with a volume and release rate index to provide sustained release of the first therapeutic agent when the first therapeutic agent 110A is injected into first device 100 implanted in the eye, and the second therapeutic device 100 can be configured with a second volume and second release rate index to provide sustained release of the second therapeutic agent 110B when the second device 100 is implanted in the eye.

[0272] Fig. 5 shows a therapeutic device having a plurality of parallel reservoirs comprising a first reservoir 140A and a second reservoir 140B. First reservoir 140A comprises a first container 130A having a first chamber 132A coupled to a first porous structure 150X. Second reservoir 140B comprises a second container 130B having a second chamber 132B coupled to a second porous structure 150Y. A first injector 187A can comprise a first amount of therapeutic agent 110A and can be coupled to first reservoir 140A to deliver therapeutic amounts of first therapeutic agent 110A. A second injector 187B can comprise a second amount of second therapeutic agent 110B and can be coupled to second reservoir 140B to deliver therapeutic amounts of second therapeutic agent 110B. Each of the first container and the second container can be tuned to the amount of therapeutic agent injected into the respective container as described herein. The first chamber 132A can be configured with a volume and the first porous structure 150X configured release rate index so as to provide sustained release of the first therapeutic agent 110A when the first therapeutic agent 110A is injected into first device 100 implanted in the eye. The second chamber 132B can be configured with a second volume and the second porous structure 150Y can be configured with a second release rate index so as to provide sustained release of the second therapeutic agent 110B when the second therapeutic agent 110B is injected into device 100 implanted in the eye. Barrier 160 may extend between first chamber 132A and second chamber 132B. Based on the teachings described herein a

person of ordinary skill in the art can determine the volume and release rate index of each chamber so as to release the therapeutic agent for the extended time.

[0273] Fig. 6A shows a therapeutic device having a plurality of reservoirs configured in series comprising a first reservoir 140A and a second reservoir 140B. First reservoir 140A  
5 comprises a first container 130A having a first chamber 132A coupled to a first porous structure 150X. Second reservoir 140B comprises a second container 130B having a second chamber 132B coupled to a second porous structure 150Y. A injector 187 can comprise a first amount of therapeutic agent 110A and can be coupled to first reservoir 140A to inject therapeutic amounts of first therapeutic agent 110A. Second injector 132B can comprise a  
10 second amount of second therapeutic agent 110B comprising a solid located within second reservoir 140B so as to deliver therapeutic amounts of first therapeutic agent 110A. The first container can be tuned to the amount of therapeutic agent injected into chamber 132A. The first chamber 132A can be configured with a volume and the first porous structure 150X configured release rate index so as to provide sustained release of the first therapeutic agent  
15 110A when the first therapeutic agent 110A is injected into first device 100 implanted in the eye. The second chamber 132B can be configured with a second volume and the second porous structure 150Y configured with a second release rate index so as to provide sustained release of the solid second therapeutic agent 110B and first therapeutic agent 110A. The first porous structure 150X may extend between first chamber 132A and second chamber 132B, and  
20 the porosity and RRI of the first porous structure 150X can be smaller than the porosity and RRI of the second porous structure 150Y such that release rate of the first therapeutic agent 110A is substantially determined based on the porosity and RRI of the first porous structure and the release rate of the second therapeutic agent is determined substantially based on the porosity and RRI of the second porous structure. Although the first therapeutic agent 110A can  
25 be released serially through the first porous structure 150X followed by release through the second porous structure 150Y, the porosity and RRI of the second porous structure 150Y can be substantially greater than the first porous structure 150X such that the release rate profile of the first therapeutic agent can be determined substantially based on the first RRI and first porosity of the first porous structure 150X. The second chamber 132B may comprise a  
30 sufficient amount of the solid second therapeutic agent such that the solid can remain in the second chamber for a plurality of injections of the first therapeutic agent, for example can

remain in the second chamber 132B for at least about one year when the device 100 is implanted in the eye. The first chamber may comprise an antineoplastic agent, for example a VEGF inhibitor such as Luentis™, and the second chamber may comprise an antiinflammatory, for example a non-steroidal anti-inflammatory such as a COX inhibitor, for example such as celocoxib. Based on the teachings described herein a person of ordinary skill in the art could conduct experiments and simulations to determine the first release rate index, volume of the first chamber, and the first injected amount so as to release the first therapeutic agent 110A for a first extended time, and determine the second release rate index, volume of the second chamber, and the second amount of second therapeutic agent 110B so as to release the first therapeutic agent 110A for the first extended time the second therapeutic agent 110B for the second extended time.

[0274] FIG. 6B shows a rigid porous structure as in FIG. 6A. The rigid porous structure 158 comprises a plurality of interconnecting channels 156. The porous structure comprises a sintered material composed of interconnected grains 155 of material. The interconnected grains of material define channels that extend through the porous material to release the therapeutic agent. The channels may extend around the sintered grains of material, such that the channels comprise interconnecting channels extending through the porous material.

[0275] The rigid porous structure can be configured for injection of the therapeutic agent into the container in many ways. The channels of the rigid porous structure may comprise substantially fixed channels when the therapeutic agent is injected into the reservoir with pressure. The rigid porous structure comprises a hardness parameter within a range from about 160 Vickers to about 500 Vickers. In some embodiments the rigid porous structure is formed from sintered stainless steel and comprises a hardness parameter within a range from about 200 Vickers to about 240 Vickers. In some embodiments it is preferred to inhibit ejection of the therapeutic agent through the porous structure during filling or refilling the reservoir of the therapeutic device with a fluid. In these embodiments the channels of the rigid porous structure comprise a resistance to flow of an injected solution or suspension through a thirty gauge needle such that ejection of said solution or suspension through the rigid porous structure is substantially inhibited when said solution or suspension is injected into the reservoir of the therapeutic device. Additionally, these embodiments may optionally comprise an evacuation

vent or an evacuation reservoir under vacuum or both to facilitate filling or refilling of the reservoir.

[0276] The reservoir and the porous structure can be configured to release therapeutic amounts of the therapeutic agent in many ways. The reservoir and the porous structure can be configured to release therapeutic amounts of the therapeutic agent corresponding to a concentration of at least about 0.1 ug per ml of vitreous humor for an extended period of at least about three months. The reservoir and the porous structure can be configured to release therapeutic amounts of the therapeutic agent corresponding to a concentration of at least about 0.1 ug per ml of vitreous humor and no more than about 10 ug per ml for an extended period of at least about three months. The therapeutic agent may comprise at least a fragment of an antibody and a molecular weight of at least about 10k Daltons. For example, the therapeutic agent may comprise one or more of ranibizumab or bevacizumab. Alternatively or in combination, the therapeutic agent may comprise a small molecule drug suitable for sustained release. The reservoir and the porous structure may be configured to release therapeutic amounts of the therapeutic agent corresponding to a concentration of at least about 0.1 ug per ml of vitreous humor and no more than about 10 ug per ml for an extended period of at least about 3 months or at least about 6 months. The reservoir and the porous structure can be configured to release therapeutic amounts of the therapeutic agent corresponding to a concentration of at least about 0.1 ug per ml of vitreous humor and no more than about 10 ug per ml for an extended period of at least about twelve months or at least about two years or at least about three years. The reservoir and the porous structure may also be configured to release therapeutic amounts of the therapeutic agent corresponding to a concentration of at least about 0.01 ug per ml of vitreous humor and no more than about 300 ug per ml for an extended period of at least about 3 months or 6 months or 12 months or 24 months.

[0277] The channels of the rigid porous structure comprise a hydrogel configured to limit a size of molecules passed through the channels of the rigid porous structure. For example, the hydrogel can be formed within the channels and may comprise an acrylamide gel. The hydrogel comprises a water content of at least about 70%. For example, the hydrogel may comprise a water content of no more than about 90% to limit molecular weight of the therapeutic agent to about 30k Daltons. The hydrogel comprises a water content of no more



than about 95% to limit molecular weight of the therapeutic agent to about 100k Daltons. The hydrogel may comprise a water content within a range from about 90% to about 95% such that the channels of the porous material are configured to pass Lucentis™ and substantially not pass Avastin™.

5 [0278] The rigid porous structure may comprise a composite porous material that can readily be formed in or into a wide range of different shapes and configurations. For example, the porous material can be a composite of a metal, aerogel or ceramic foam (i.e., a reticulated inter-cellular structure in which the interior cells are interconnected to provide a multiplicity of pores passing through the volume of the structure, the walls of the cells themselves being  
10 substantially continuous and non-porous, and the volume of the cells relative to that of the material forming the cell walls being such that the overall density of the intercellular structure is less than about 30 percent theoretical density) the through pores of which are impregnated with a sintered powder or aerogel. The thickness, density, porosity and porous characteristics of the final composite porous material can be varied to conform with the desired release of the  
15 therapeutic agent.

[0279] Embodiments comprise a method of making an integral (i.e., single-component) porous structure. The method may comprise introducing particles into a mold having a desired shape for the porous structure. The shape includes a proximal end defining a plurality of proximal porous channel openings to couple to the reservoir, a distal end defining a plurality of  
20 outlet channel openings to couple to the vitreous humor of the eye, a plurality of blind inlet cavities extending into the filter from the proximal openings, and a plurality of blind outlet cavities extending into the porous structure from the outlet channel openings. The method further includes applying pressure to the mold, thereby causing the particles to cohere and form a single component, and sintering the component to form the porous structure. The particles can  
25 be pressed and cohere to form the component without the use of a polymeric binder, and the porous structure can be formed substantially without machining.

[0280] The mold can be oriented vertically with the open other end disposed upwardly, and metal powder having a particle size of less than 20 micrometers can be introduced into the cavity through the open end of the mold while vibrating the mold to achieve substantially  
30 uniform packing of the metal powder in the cavity. A cap can be placed on the open other end

of the mold, and pressure is applied to the mold and thereby to the metal powder in the cavity to cause the metal powder to cohere and form a cup-shaped powdered metal structure having a shape corresponding to the mold. The shaped powdered metal structure can be removed from the mold, and sintered to obtain a porous sintered metal porous structure.

- 5 [0281] The metal porous structure can be incorporated into the device by a press fit into an impermeable structure with an opening configured to provide a tight fit with the porous structure. Other means, such as welding, known to those skilled in the art can be used to incorporate the porous structure into the device. Alternatively, or in combination, the powdered metal structure can be formed in a mold where a portion of the mold remains with the shaped  
10 powdered metal structure and becomes part of the device. This may be advantageous in achieving a good seal between the porous structure and the device.

- [0282] The release rate of therapeutic agent through a porous body, such as a sintered porous metal structure or a porous glass structure, may be described by diffusion of the of the therapeutic agent within the porous structure with the channel parameter, and with an effective  
15 diffusion coefficient equal to the diffusion coefficient of the therapeutic agent in the liquid that fills the reservoir multiplied by the Porosity and a Channel Parameter of the porous body:

Release Rate =  $(D P / F) A (c_R - c_V) / L$ , where:

$c_R$  = Concentration in reservoir

$c_V$  = Concentration outside of the reservoir or in the vitreous

- 20 D = Diffusion coefficient of the therapeutic agent in the reservoir solution

P = Porosity of porous structure

F = Channel parameter that may correspond to a tortuosity parameter of channels of porous structure

A = Area of porous structure

- 25 L = Thickness (length) of porous structure

Cumulative Release =  $1 - c_R/c_{R0} = 1 - \exp((- D P A / F L V_R) t)$ , where  
t = time,  $V_R$  = reservoir volume

- [0283] The release rate index can (hereinafter RRI) be used to determine release of the  
30 therapeutic agent. The RRI may be defined as  $(PA/FL)$ , and the RRI values herein will have units of mm unless otherwise indicated. Many of the porous structures used in the therapeutic delivery devices described here have an RRI of no more than about 5.0, often no more than about 2.0, and can be no more than about 1.2 mm.

[0284] The channel parameter can correspond to an elongation of the path of the therapeutic agent released through the porous structure. The porous structure may comprise many interconnecting channels, and the channel parameter can correspond to an effective length that the therapeutic agent travels along the interconnecting channels of the porous structure from the reservoir side to the vitreous side when released. The channel parameter multiplied by the thickness (length) of the porous structure can determine the effective length that the therapeutic agent travels along the interconnecting channels from the reservoir side to the vitreous side. For example, the channel parameter (F) of about 1.5 corresponds to interconnecting channels that provide an effective increase in length traveled by the therapeutic agent of about 50%, and for a 1 mm thick porous structure the effective length that the therapeutic agent travels along the interconnecting channels from the reservoir side to the vitreous side corresponds to about 1.5 mm. The channel parameter (F) of at least about 2 corresponds to interconnecting channels that provide an effective increase in length traveled by the therapeutic agent of about 100%, and for a 1 mm thick porous structure the effective length that the therapeutic agent travels along the interconnecting channels from the reservoir side to the vitreous side corresponds to at least about 2.0 mm. As the porous structure comprises many interconnecting channels that provide many alternative paths for release of the therapeutic agent, blockage of some of the channels provides no substantial change in the effective path length through the porous structure as the alternative interconnecting channels are available, such that the rate of diffusion through the porous structure and the release of the therapeutic agent are substantially maintained when some of the channels are blocked.

[0285] If the reservoir solution is aqueous or has a viscosity similar to water, the value for the diffusion coefficient of the therapeutic agent (TA) in water at the temperature of interest may be used. The following equation can be used to estimate the diffusion coefficient at 37°C from the measured value of  $D_{BSA,20C} = 6.1 \text{ e-}7 \text{ cm}^2/\text{s}$  for bovine serum albumin in water at 20°C (Molokhia et al, *Exp Eye Res* 2008):

$$D_{TA,37C} = D_{BSA,20C} (\eta_{20C} / \eta_{37C}) (MW_{BSA} / MW_{TA})^{1/3} \text{ where}$$

MW refers to the molecular weight of either BSA or the test compound and  $\eta$  is the viscosity of water, and Table 3 lists diffusion coefficients of proteins of interest.

Table 3. Diffusion Coefficients

Compound	MW	Temp C	Diff Coeff (cm <sup>2</sup> /s)
BSA	69,000	20	6.1E-07
BSA	69,000	37	9.1E-07
Ranibizumab	48,000	20	6.9E-07
Ranibizumab	48,000	37	1.0E-06
Bevacizumab	149,000	20	4.7E-07
Bevacizumab	149,000	37	7.1E-07

Small molecules have a diffusion coefficient similar to fluorescein (MW = 330, D = 4.8 to 6 e-6 cm<sup>2</sup>/s from Stay, MS et al. *Pharm Res* **2003**, 20(1), pp. 96-102). For example, the small molecule may comprise a glucocorticoid such as triamcinolone acetonide having a molecular weight of about 435.

[0286] The porous structure comprises a porosity, a thickness, a channel parameter and a surface area configured to release therapeutic amounts for the extended period. The porous material may comprise a porosity corresponding to the fraction of void space of the channels extending within the material. The porosity comprises a value within a range from about 3% to about 70%. In other embodiments, the porosity comprises a value with a range from about 5% to about 10% or from about 10% to about 25%, or for example from about 15% to about 20%. Porosity can be determined from the weight and macroscopic volume or can be measured via nitrogen gas adsorption

[0287] The porous structure may comprise a plurality of porous structures, and the area used in the above equation may comprise the combined area of the plurality of porous structures.

[0288] The channel parameter may comprise a fit parameter corresponding to the tortuosity of the channels. For a known porosity, surface area and thickness of the surface parameter, the curve fit parameter F, which may correspond to tortuosity of the channels can be determined based on experimental measurements. The parameter PA/FL can be used to determine the desired sustained release profile, and the values of P, A, F and L determined. The rate of release of the therapeutic agent corresponds to a ratio of the porosity to the channel parameter, and the ratio of the porosity to the channel parameter can be less than about 0.5 such that the porous structure releases the therapeutic agent for the extended period. For example, the ratio of the porosity to the channel parameter is less than about 0.1 or for example less than about 0.2

such that the porous structure releases the therapeutic agent for the extended period. The channel parameter may comprise a value of at least about 1, such as at least about 1.2. For example, the value of the channel parameter may comprise at least about 1.5, for example at least about 2, and may comprise at least about 5. The channel parameter can be within a range  
 5 from about 1.1 to about 10, for example within a range from about 1.2 to about 5. A person of ordinary skill in the art can conduct experiments based on the teachings described herein to determine empirically the channel parameter to release the therapeutic agent for an intended release rate profile.

[0289] The area in the model originates from the description of mass transported in units of  
 10 flux; i.e., rate of mass transfer per unit area. For simple geometries, such as a porous disc mounted in an impermeable sleeve of equal thickness, the area corresponds to one face of the disc and the thickness,  $L$ , is the thickness of the disc. For more complex geometries, such as a porous body in the shape of a truncated cone, the effective area is a value in between the area where therapeutic agent enters the porous body and the area where therapeutic agent exits the  
 15 porous body.

[0290] A model can be derived to describe the release rate as a function of time by relating the change of concentration in the reservoir to the release rate described above. This model assumes a solution of therapeutic agent where the concentration in the reservoir is substantially uniform. In addition, the concentration in the receiving fluid or vitreous is considered  
 20 negligible ( $c_v = 0$ ). Solving the differential equation and rearrangement yields the following equations describing the concentration in the reservoir as a function of time,  $t$ , and volume of the reservoir,  $V_R$ , for release of a therapeutic agent from a solution in a reservoir through a porous structure.

$$c_R = c_{R0} \exp((-DPA / FL V_R) t)$$

25

$$\text{and Cumulative Release} = 1 - c_R / c_{R0}$$

[0291] When the reservoir contains a suspension, the concentration in reservoir,  $c_R$ , is the dissolved concentration in equilibrium with the solid (i.e., the solubility of the therapeutic agent). In this case, the concentration in the reservoir is constant with time, the release rate is

zero order, and the cumulative release increases linearly with time until the time when the solid is exhausted.

[0292] Therapeutic concentrations for many ophthalmic therapeutic agents may be determined experimentally by measuring concentrations in the vitreous humor that elicit a therapeutic effect. Therefore, there is value in extending predictions of release rates to predictions of concentrations in the vitreous. A one-compartment model may be used to describe elimination of therapeutic agent from eye tissue.

[0293] Current intravitreal administration of therapeutic agents such as Lucentis™ involves a bolus injection. A bolus injection into the vitreous may be modeled as a single exponential with rate constant,  $k = 0.693/\text{half-life}$  and a  $c_{\text{max}} = \text{dose} / V_v$  where  $V_v$  is the vitreous volume. As an example, the half-life for ranibizumab is approximately 3 days in the rabbit and the monkey (Gaudreault et al) and 9 days in humans (Lucentis™ package insert). The vitreous volume is approximately 1.5 mL for the rabbit and monkey and 4.5 mL for the human eye. The model predicts an initial concentration of 333 ug/mL for a bolus injection of 0.5 mg Lucentis™ into the eye of a monkey. This concentration decays to a vitreous concentration of 0.1 ug/mL after about a month.

[0294] For devices with extended release, the concentration in the vitreous changes slowly with time. In this situation, a model can be derived from a mass balance equating the release rate from the device (described by equations above) with the elimination rate from the eye,  $k c_v V_v$ . Rearrangement yields the following equation for the concentration in the vitreous:

$$c_v = \text{Release rate from device} / k V_v.$$

[0295] Since the release rate from a device with a solution of therapeutic agent decreases exponentially with time, the concentration in the vitreous decreases exponentially with the same rate constant. In other words, vitreous concentration decreases with a rate constant equal to  $D PA / FL V_R$  and, hence, is dependent on the properties of the porous structure and the volume of the reservoir.

[0296] Since the release rate is zero order from a device with a suspension of therapeutic agent, the vitreous concentration will also be time-independent. The release rate will depend on

the properties of the porous structure via the ratio, PA / FL , but will be independent of the volume of the reservoir until the time at which the drug is exhausted.

5 [0297] The channels of the rigid porous structure can be sized in many ways to release the intended therapeutic agent. For example, the channels of the rigid porous structure can be sized to pass therapeutic agent comprising molecules having a molecular weight of at least about 100 Daltons or for example, at least about 50k Daltons. The channels of the rigid porous structure can be sized to pass therapeutic agent comprising molecules comprising a cross-sectional size of no more than about 10 nm. The channels of the rigid porous structure comprise interconnecting channels configured to pass the therapeutic agent among the interconnecting  
10 channels. The rigid porous structure comprises grains of rigid material and wherein the interconnecting channels extend at least partially around the grains of rigid material to pass the therapeutic agent through the porous material. The grains of rigid material can be coupled together at a loci of attachment and wherein the interconnecting channels extend at least partially around the loci of attachment.

15 [0298] The porous structure and reservoir may be configured to release the glucocorticoid for an extended time of at least about six months with a therapeutic amount of glucocorticoid of corresponding to an in situ concentration within a range from about 0.05 ug/mL to about 4 ug/mL, for example from 0.1 ug/mL to about 4 ug/mL, so as to suppress inflammation in the retina-choroid.

20 [0299] The porous structure comprises a sintered material. The sintered material may comprise grains of material in which the grains comprise an average size of no more than about 20 um. For example, the sintered material may comprise grains of material in which the grains comprise an average size of no more than about 10 um, an average size of no more than about 5 um, or an average size of no more than about 1 um. The channels are sized to pass therapeutic  
25 quantities of the therapeutic agent through the sintered material for the extended time based on the grain size of the sintered material and processing parameters such as compaction force and time and temperature in the furnace. The channels can be sized to inhibit penetration of microbes including bacteria and fungal spores through the sintered material.

30 [0300] The sintered material comprises a wettable material to inhibit bubbles within the channels of the material.

[0301] The sintered material comprises at least one of a metal, a ceramic, a glass or a plastic. The sintered material may comprises a sintered composite material, and the composite material comprises two or more of the metal, the ceramic, the glass or the plastic. The metal comprises at least one of Ni, Ti, nitinol, stainless steel including alloys such as 304, 304L, 316 or 316L, cobalt chrome, elgiloy, hastelloy, c-276 alloy or Nickel 200 alloy. The sintered material may comprise a ceramic. The sintered material may comprise a glass. The plastic may comprise a wettable coating to inhibit bubble formation in the channels, and the plastic may comprise at least one of polyether ether ketone (PEEK), polyethylene, polypropylene, polyimide, polystyrene, polycarbonate, polyacrylate, polymethacrylate, or polyamide.

[0302] The rigid porous structure may comprise a plurality of rigid porous structures coupled to the reservoir and configured to release the therapeutic agent for the extended period. For example, additional rigid porous structure can be disposed along the container, for example the end of the container may comprise the porous structure, and an additional porous structure can be disposed along a distal portion of the container, for example along a tubular sidewall of the container.

[0303] The therapeutic device can be tuned to release therapeutic amounts of the therapeutic agent above the minimum inhibitory concentration for an extended time based on bolus injections of the therapeutic agent. For example, the volume of the chamber of the reservoir can be sized with the release rate of the porous structure based on the volume of the bolus injection. A formulation of a therapeutic agent can be provided, for example a known intravitreal injection formulation. The therapeutic agent can be capable of treating the eye with bolus injections, such that the formulation has a corresponding period between each of the bolus injections to treat the eye. For example the bolus injections may comprise monthly injections. Each of the bolus injections comprises a volume of the formulation, for example 50 uL. Each of the bolus injections of the therapeutic agent may correspond to a range of therapeutic concentrations of the therapeutic agent within the vitreous humor over the time course between injections, and the device can be tuned so as to release therapeutic amounts of the therapeutic agent such that the vitreous concentrations of the released therapeutic agent from the device are within the range of therapeutic concentrations of the corresponding bolus injections. For example, the therapeutic agent may comprise a minimum inhibitory



concentration to treat the eye, for example at least about 3 ug/mL, and the values of the range of therapeutic concentrations can be at least about 3 ug/mL. The therapeutic device can be configured to treat the eye with an injection of the monthly volume of the formulation into the device, for example through the penetrable barrier. The reservoir of the container has a  
5 chamber to contain a volume of the therapeutic agent, for example 35 uL, and a mechanism to release the therapeutic agent from the chamber to the vitreous humor.

[0304] The volume of the container and the release mechanism can be tuned to treat the eye with the therapeutic agent with vitreous concentrations within the therapeutic range for an extended time with each injection of the quantity corresponding to the bolus injection, such that  
10 the concentration of the therapeutic agent within the vitreous humor remains within the range of therapeutic concentrations and comprises at least the minimum inhibitory concentration. The extended time may comprise at least about twice the corresponding period of the bolus injections. The release mechanism comprises one or more of a porous frit, a sintered porous frit, a permeable membrane, a semi-permeable membrane, a capillary tube or a tortuous  
15 channel, nano-structures, nano-channels or sintered nano-particles. For example, the porous frit may comprises a porosity, cross sectional area, and a thickness to release the therapeutic agent for the extended time. The volume of the container reservoir can be sized in many ways in relation to the volume of the injected formulation and can be larger than the volume of injected formulation, smaller than the volume of injected formulation, or substantially the same  
20 as the volume of injected formulation. For example, the volume of the container may comprise no more than the volume of the formulation, such that at least a portion of the formulation injected into the reservoir passes through the reservoir and comprises a bolus injection to treat the patient immediately. As the volume of the reservoir is increased, the amount of formulation released to the eye through the porous structure upon injection can decrease along with the  
25 concentration of active ingredient of the therapeutic agent within the reservoir, and the release rate index can be increased appropriately so as to provide thereapeutic amounts of therapeutic agent for the extended time. For example, the volume of the reservoir of the container can be greater than the volume corresponding to the bolus injection, so as to provide therapeutic amounts for at least about five months, for example 6 months, with an injection volume  
30 corresponding to a monthly injection of Lucentis<sup>TM</sup>. For example, the formulation may comprise commercially available Lucentis<sup>TM</sup>, 50 uL, and the reservoir may comprise a volume

of about 100 uL and provide therapeutic vitreous concentrations of at least about 3 ug/mL for six months with 50 uL of Lucentis™ injected into the reservoir.

[0305] The chamber may comprise a substantially fixed volume and the release rate mechanism comprises a substantially rigid structure to maintain release of the therapeutic agent above the minimum inhibitory concentration for the extended time with each injection of a plurality of injections.

[0306] A first portion of the injection may pass through the release mechanism and treat the patient when the formulation is injected, and a second portion of the formulation can be contained in the chamber when the formulation is injected.

[0307] FIG. 6B-1 shows interconnecting channels 156 extending from first side 150S1 to second side 150S2 of the porous structure as in FIG. 6B. The interconnecting channels 156 extend to a first opening 158A1, a second opening 158A2 and an Nth opening 158AN on the first side 150S1. The interconnecting channels 156 extend to a first opening 158B1, a second opening 158B2 and an Nth opening 158BN on the second side 150S2. Each of the openings of the plurality of channels on the first side is connected to each of the openings of plurality of channels on the second side, such that effective length traveled along the channels is greater than thickness 150T. The channel parameter can be within a range from about 1.1 to about 10, such that the effective length is within a range from about 1.1 to 10 times the thickness 150T. For example, the channel parameter can be about 1 and the porosity about 0.2, such that the effective length corresponds to at least about 5 times the thickness 150T.

[0308] FIG. 6B-2 shows a plurality of paths of the therapeutic agent along the interconnecting channels extending from a first side 150S1 to a second side 150S2 of the porous structure as in FIGS. 6B and 6B-1. The plurality of paths comprises a first path 156P1 extending from the first side to the second side, a second path 156P2 extending from the first side to the second side and a third path 156P3 extending from the first side to the second side, and many additional paths. The effect length of each of first path P1, second path P2 and third path P3 is substantially similar, such that each opening on the first side can release the therapeutic agent to each interconnected opening on the second side. The substantially similar path length can be related to the sintered grains of material and the channels that extend around the sintered material. The porous structure may comprise randomly oriented and connected

grains of material, packed beads of material, or combinations thereof. The channel parameter can be related to the structure of the sintered grains of material and corresponding interconnecting channels, porosity of the material, and percolation threshold. Work in relation to embodiments shows that the percolation threshold of the sintered grains may be below the porosity of the porous frit structure, such that the channels are highly inter-connected. The sintered grains of material can provide interconnected channels, and the grains can be selected to provide desired porosity and channel parameters and RRI as described herein.

**[0309]** The channel parameter and effective length from the first side to the second side can be configured in many ways. The channel parameter can be greater than 1 and within a range from about 1.2 to about 5.0, such that the effective length is within a range about 1.2 to 5.0 times the thickness  $150T$ , although the channel parameter may be greater than 5, for example within a range from about 1.2 to 10. For example, the channel parameter can be from about 1.3 to about 2.0, such that the effective length is about 1.3 to 2.0 times the thickness  $150T$ . For example, experimental testing has shown the channel parameter can be from about 1.4 to about 1.8, such that the effective length is about 1.4 to 1.8 times the thickness  $150T$ , for example about 1.6 times the thickness. These values correspond to the paths of the channels around the sintered grains of material, and may correspond, for example, to the paths of channels around packed beads of material.

**[0310]** FIG. 6B-3 shows blockage of the openings with a covering  $156B$  and the plurality of paths of the therapeutic agent along the interconnecting channels extending from a first side to a second side of the porous structure as in FIGS. 6B and 6B-1. A plurality of paths  $156PR$  extend from the first side to the second side couple the first side to the second side where one of the sides is covered, such that the flow rate is maintained when one of the sides is partially covered.

**[0311]** FIG. 6B-4 shows blockage of the openings with particles  $156PB$  and the plurality of paths of the therapeutic agent along the interconnecting channels extending from a first side to a second side of the porous structure as in FIGS. 6B and 6B-1. The plurality of paths  $156PR$  extend from the first side to the second side couple the first side to the second side where one of the sides is covered, such that the flow rate is maintained when one of the sides is partially covered

[0312] FIG. 6B-5 shows an effective cross-sectional size 150DE and area 150EFF corresponding to the plurality of paths of the therapeutic agent along the interconnecting channels extending from a first side to a second side of the porous structure as in FIGS. 6B and 6B-1. The effective cross sectional area of the interconnecting channels corresponds to the  
5 internal cross-sectional area of the porous structure disposed between the openings of the first side and the openings of the second side, such that the rate of release can be substantially maintained when the channels are blocked on the first side and the second side.

[0313] The rigid porous structure can be shaped and molded in many ways for example with tubular shapes, conical shapes, discs and hemispherical shapes. The rigid porous structure may  
10 comprise a molded rigid porous structure. The molded rigid porous structure may comprises at least one of a disk, a helix or a tube coupled to the reservoir and configured to release the therapeutic agent for the extended period.

[0314] FIG. 6C shows a rigid porous structure as in FIG. 6B incorporated into a scleral tack 601 as described in U.S. Pat. No. 5,466,233. The scleral tack comprises a head 602, a central  
15 portion 603 and a post 604. The post may comprise the reservoir 605 and the rigid porous structure 606 as described above. The porous structure may comprise a molded conical structure having a sharp tip configured for insertion into the patient. Alternatively or in combination, the tip may be rounded.

[0315] FIG. 6E, shows a plurality of rigid porous structures as in FIG. 6B incorporated with a  
20 drug delivery device for sustained release as described in U.S. Pat. No. 5,972,369. The therapeutic device comprises a reservoir 613 to contain the therapeutic agent and an impermeable and non-porous outer surface 614. The reservoir is coupled to a rigid porous structure 615 that extends to a distal end 617. The rigid porous structure comprises an exposed area 616 on the distal end to release the therapeutic agent, and the impermeable and non-porous  
25 outer surface may extend to the distal end.

[0316] FIG. 6D shows a rigid porous structure as in FIG. 6B incorporated with a delivery  
device for sustained release as described in U.S. Pat. Pub. 2003/0014036 A1. The drug  
delivery device comprises an inlet port 608 on the proximal end and a hollow body 609 coupled  
to the inlet port. The hollow body comprises many openings 612 that allow a solution injected  
30 into the inlet port to pass from the hollow body into a balloon 610. The balloon comprises a

distal end 611 disposed opposite the injection port. The balloon comprises a plurality of the rigid porous structures 607, as described above. Each of the plurality of porous rigid structures comprises a first surface exposed to the interior of the balloon and a second surface configured to contact the vitreous. The calculated area can be the combined area of the plurality of porous rigid structures as noted above.

[0317] FIG. 6F shows a rigid porous structure as in FIG. 6B incorporated with a non-linear body member 618 for sustained release as described in U.S. Pat. No. 6,719,750. The non-linear member may comprise a helical shape. The non-linear member can be coupled to a cap 619 on the proximal end 620. The non-linear member may comprise a lumen 621 filled with therapeutic agent so as to comprise a reservoir 622. The porous structure 623 can be disposed on a distal end 624 of the non-linear member to release the therapeutic agent. The porous structure may be located at additional or alternative locations of the non-linear member. For example a plurality of porous structures may be disposed along the non-linear member at locations disposed between the cap and distal end so as to release therapeutic agent into the vitreous humor when the cap is positioned against the sclera.

[0318] FIG. 6G shows porous nanostructures, in accordance with embodiments. The porous structure 150 may comprise a plurality of elongate nano-channels 156NC extending from a first side 150S1 of the porous structure to a second side 150S2 of the porous structure. The porous structure 150 may comprise a rigid material having the holes formed thereon, and the holes may comprise a maximum dimension across such as a diameter. The diameter of the nano-channels may comprise a dimension across, for example from about 10 nm across, to about 1000 nm across, or larger. The channels may be formed with etching of the material, for example lithographic etching of the material. The channels may comprise substantially straight channels such that the channel parameter  $F$  comprises about 1, and the parameters area  $A$ , and thickness or length  $L$  correspond to the combined cross-sectional area of the channels and the thickness or length of the porous structure.

[0319] The porous structure 150 may comprise interconnecting nano-channels, for example formed with a sintered nano-material.

[0320] The injection of therapeutic agent into the device 100 as described herein can be performed before implantation into the eye or alternatively when the therapeutic device is implanted into the eye.

5 [0321] FIG. 7 shows a therapeutic device 100 coupled to an injector 701 that removes material from the device and injects therapeutic agent 702 into the device. The injector picks up spent media 703 and refills the injector with fresh therapeutic agent. The therapeutic agent is injected into the therapeutic device. The spent media is pulled up into the injector. The injector may comprise a stopper mechanism 704.

10 [0322] The injector 701 may comprise a first container 702C to contain a formulation of therapeutic agent 702 and a second container 703C to receive the spent media 703. Work in relation to embodiments suggests that the removal of spent media 703 comprising material from the container reservoir of the therapeutic device can remove particulate from the therapeutic device, for example particles comprised of aggregated therapeutic agent such as protein. The needle 189 may comprise a double lumen needle with a first lumen coupled to the  
15 first container and a second lumen coupled to the second container, such that spent media 703 passes from the container reservoir of device 100 to the injector. A valve 703V, for example a vent, can be disposed between the second lumen and the second container. When the valve is open and therapeutic agent is injected, spent media 703 from the container reservoir of the therapeutic device 100 passes to the second container of the injector, such that at least a portion  
20 of the spent media within the therapeutic device is exchanged with the formulation. When the valve is closed and the therapeutic agent is injected, a portion of the therapeutic agent passes from the reservoir of the therapeutic device into the eye. For example, a first portion of formulation of therapeutic agent can be injected into therapeutic device 100 when the valve is open such that the first portion of the formulation is exchanged with material disposed within  
25 the reservoir; the valve is then closed and a second portion of the formulation is injected into therapeutic device 100 such that at least a portion of the first portion passes through the porous structure into the eye. Alternatively or in combination, a portion of the second portion of injected formulation may pass through the porous structure when the second portion is injected into the eye. The second portion of formulation injected when the valve is closed may

correspond to a volume of formulation that passes through the porous structure into the vitreous humor to treat the patient immediately.

[0323] The needle 189 may comprise a dual lumen needle, for example.

[0324] Fig. 7A shows a therapeutic device having a reservoir 140 tuned to receive an injection of a first amount of first therapeutic agent 110A and a second amount of second therapeutic agent 110B. The first amount of first therapeutic agent 110A and the second amount of second therapeutic agent 110B can be mixed together and injected from injector 187. Reservoir 140 comprises container 130 having chamber 132 coupled to porous structure 150. The container can be tuned with the volume and RRI of the porous structure to receive the first amount of first therapeutic agent 110A and second amount of second therapeutic agent 110B injected into chamber 132 with the first amount. Based on the teachings described herein a person of ordinary skill in the art can conduct experiments and simulations to determine the release rate index, volume of the chamber, the first amount and the second amount so as to release the first therapeutic agent 110A for a first extended time and the second therapeutic agent 110B for a second extended time.

[0325] FIG. 7A-1 shows a therapeutic device 100 comprising a penetrable barrier coupled to an injector needle 189 comprising a stop 189S that positions the distal end of the needle near the proximal end of the reservoir 130 of the device to flush the reservoir with ejection of liquid formulation through the porous frit structure, in accordance with embodiments. For example, the injector needle may comprise a single lumen needle having a bevel that extends approximately 0.5 mm along the shaft of the needle from the tip of the needle to the annular portion of the needle. The stop can be sized and positioned along an axis of the needle such that the needle tip extends a stop distance 189SD into the reservoir as defined by the length of the needle from the stop to the tip and the thickness of the penetrable barrier, in which the stop distance is within a range from about 0.5 to about 2 mm. The reservoir may extend along an axis of the therapeutic device distance within a range from about 4 to 8 mm. A volume comprising a quantity of liquid formulation within a range from about 20 to about 200 uL, for example about 50 uL can be injected into the therapeutic device with the needle tip disposed on the distal end. The volume of the reservoir can be less than the injection volume of the formulation of therapeutic agent, such that liquid is flushed through the porous structure 150.

For example, the reservoir may comprise a volume within a range from about 20 to 40 uL, and the injection volume of the liquid formulation of therapeutic agent may comprise about 40 to 100 uL, for example about 50 uL.

[0326] FIG. 7A-2 shows a therapeutic device comprising a penetrable barrier coupled to a  
5 needle 189 of an injector 701 to inject and remove material from the device such that the liquid in the reservoir 130 is exchanged with the injected formulation. The needle comprises at least one lumen and may comprise a concentric double lumen needle 189DL with a distal end coupled to the inner lumen to inject formulation of the therapeutic agent into the therapeutic device and a proximal vent 189V to receive liquid into the needle when the formulation is  
10 injected. Alternatively, the vent may correspond to an opening on the distal end of the inner lumen of the needle and the outer lumen may comprise a proximal opening to inject therapeutic agent formulation into a proximal portion of the container reservoir.

[0327] Work in relation to the injector embodiments indicates that a filling efficiency of at least about 80%, for example 90% or more can be achieved with injector apparatus and needles  
15 as described above.

[0328] FIG. 7B-1 shows a side cross-sectional view of therapeutic device 100 comprising a retention structure having a cross-section sized to fit in an elongate incision. The retention structure shown can be combined with one or more therapeutic agents as described herein. For example, the volume and RRI can be tuned to receive a quantity of the first therapeutic agent  
20 by injection, and the second therapeutic agent 110B may comprise a solid located in the chamber 132. The release rate index and volume of chamber 132 can be sized to receive a quantity of first therapeutic agent 110A. The release rate index can be sized to release therapeutic amounts of the second therapeutic agent 110B for a second extended time. Based on the teachings described herein a person of ordinary skill in the art can conduct experiments  
25 and simulations to determine the release rate index, volume of the chamber, the first amount and the second amount so as to release the first therapeutic agent 110A for a first extended time and the second therapeutic agent 110B for a second extended time through the porous structure 150.

[0329] The cross-section sized to fit in the elongate incision may comprise a narrow portion  
30 120N of retention structure 120 that is sized smaller than the flange 122. The narrow portion



120N sized to fit in the elongate incision may comprise an elongate cross section 120NE sized to fit in the incision. The narrow portion 120N may comprise a cross-section having a first cross-sectional distance across, or first dimensional width, and a second cross-sectional distance across, or second dimensional width, in which the first cross-sectional distance across is greater than the second cross-sectional distance across such that the narrow portion 120N comprises an elongate cross-sectional profile.

[0330] The elongate cross section 120NE of the narrow portion 120N can be sized in many ways to fit the incision. The elongate cross section 120NE comprises a first dimension longer than a second dimension and may comprise one or more of many shapes such as dilated slot, dilated slit, lentoid, oval, ovoid, or elliptical. The dilated slit shape and dilated slot shape may correspond to the shape sclera tissue assumes when cut and dilated. The lentoid shape may correspond to a biconvex lens shape. The elongate cross-section of the narrow portion may comprise a first curve along an first axis and a second curve along a second axis different than the first curve.

[0331] Similar to the narrow portion 120N of the retention structure, the container reservoir may comprise a cross-sectional profile.

[0332] FIG. 7B-2 shows an isometric view of the therapeutic device as in FIG. 7B-1.

[0333] FIG. 7B-3 shows a top view of the therapeutic device as in FIG. 7B-1.

[0334] FIG. 7B-4 shows a side cross sectional view along the short side of the retention structure of the therapeutic device as in FIG. 7B-1.

[0335] FIG. 7B-5 shows a bottom view of the therapeutic device as in FIG. 7B-1 implanted in the sclera.

[0336] FIG. 7B-5A shows a cutting tool 710 comprising a blade 714 having a width 712 corresponding to perimeter 160P of the barrier 160 and the perimeter 160NP of the narrow portion. The cutting tool can be sized to the narrow portion 120N so as to seal the incision with the narrow portion when the narrow portion is positioned against the sclera. For example, the width 712 may comprise about one half of the perimeter 160P of the barrier 160 and about one half of the perimeter 160NP of the narrow portion 160N. For example, the outside diameter of

the tube of barrier 160 may comprise about 3 mm such that the perimeter of 160P comprises about 6 mm, and the narrow portion perimeter 160NP may comprise about 6 mm. The width 712 of the blade 710 may comprise about 3 mm such that the incision comprises an opening having a perimeter of about 6 mm so as to seal the incision with the narrow portion 160P.

5 Alternatively, perimeter 160P of barrier 160 may comprise a size slightly larger than the incision and the perimeter of the narrow portion.

[0337] The retention structure comprises a narrow section 120N having a short distance 120NS and a long distance 120NL so as to fit in an elongate incision along the pars plana of the eye. The retention structure comprises an extension 122. The extension of the retention  
10 structure 120E comprises a short distance across 122S and a long distance across 122S, aligned with the short distance 122NS and long distance 122NL of the narrow portion 120N of the retention structure 120. The narrow portion 120 may comprise an indentation 120I sized to receive the sclera.

[0338] FIGS. 8A and 8A1 show a side cross sectional view and a top view, respectively, of  
15 therapeutic device 100 for placement substantially between the conjunctiva and the sclera. The therapeutic agent 110 as described herein can be injected when device 100 is implanted. The therapeutic device 100 comprises container 130 as described herein having penetrable barrier 184 as described herein disposed on an upper surface for placement against the conjunctiva. An elongate structure 172 is coupled to container 130. Elongate structure 172 comprises a  
20 channel 174 extending from a first opening coupled to the chamber of the container to a second opening 176 on a distal end of the elongate structure. The porous structure 150 as described herein is located on the elongate structure 172 and coupled to the container 130 so as to release therapeutic agent for an extended period, and a retention structure 120 comprising an extension protruding outward from the container 130 to couple to the sclera and the conjunctiva. The  
25 container may comprise barrier 160 as described herein that defines at least a portion of the reservoir, and the container may comprise a width, for example a diameter. The barrier 160 may comprise a rigid material, for example rigid silicone or rigid rubber, or other material as described herein, such that the volume of the chamber of container 130 comprises a substantially constant volume as described herein. Alternatively or in combination, barrier 160  
30 may comprise a soft material, for example when the chamber size is decreased such that the

volume can be substantially constant with the decreased chamber size. A soft barrier material can be combined with a rigid material, for example a support material. The diameter can be sized within a range, for example within a range from about 1 to about 8 mm, for example within a range from about 2 to 6 mm and can be about 3 mm, for example.

5 [0339] The container may be coupled to elongate structure 172 sized, and the elongate structure having a length sized so as to extend from the conjunctive to the vitreous to release the therapeutic agent into the vitreous. The length can be sized within a range, for example within a range from about 2 to about 14 mm, for example within a range from about 4 to 10 mm and can be about 7 mm, for example. The penetrable barrier may comprise a septum  
10 disposed on a proximal end of the container, in which the septum comprises a barrier that can be penetrated with a sharp object such as a needle for injection of the therapeutic agent. The porous structure may comprise a cross sectional area sized to release the therapeutic agent for the extended period. The elongate structure 172 can be located near a center of the container 130, or may be eccentric to the center.

15 [0340] The elongate structure 172 can be inserted into the sclera at the pars plana region as described herein.

[0341] The barrier 160 can have a shape profile for placement between the conjunctiva and sclera. The lower surface can be shaped to contact the sclera and may comprise a concave shape such as a concave spherical or toric surface. The upper surface can be shaped to contact  
20 the conjunctivae and may comprise a convex shape such as a convex spherical or toric surface. The barrier 160 may comprise an oval, an elliptical, or a circular shape when implanted and viewed from above, and the elongate structure 172 can be centered or eccentric to the ellipse. When implanted the long dimension of the oval can be aligned so as to extend along a circumference of the pars plana.

25 [0342] The cross sectional diameter of the elongate structure 172 can be sized to decrease the invasiveness of device 100, and may comprise a diameter of no more than about 1 mm, for example no more than about 0.5 mm, for example no more than about 0.25 mm such that the penetrate sclera seals substantially when elongate structure 172 is removed and the eye can seal itself upon removal of elongate structure 172. The elongate structure 172 may comprise a  
30 needle, and channel 174 may comprise a lumen of the needle, for example a 30 Gauge needle.

[0343] The porous structure 150 may comprise a first side as described herein coupled to the reservoir and a second side to couple to the vitreous. The first side may comprise a first area 150 as described herein and the second side may comprise a second area. The porous structure may comprise a thickness as described herein. The porous structure may comprise a diameter.

5 The porous structure may comprise a release rate index, and the chamber of container 130 that defines the volume of reservoir 140 can be sized such that the porous structure and the volume are tuned to receive and amount of therapeutic agent injected with a volume of formulation of therapeutic agent and tuned to release therapeutic amounts for an extended time. Many release rate mechanisms as described herein can be used to tune the release rate and volume to the

10 quantity of therapeutic agent injected as described herein.

[0344] The volume of the reservoir 140 defined by the chamber of the container may comprise from about 5 uL to about 2000 uL of therapeutic agent, or for example from about 10 uL to about 200 uL of therapeutic agent.

[0345] The porous structure may comprise a needle stop that limits penetration of the needle.

15 The porous structure may comprise a plurality of channels configured for the extended release of the therapeutic agent. The porous structure may comprise a rigid sintered material having characteristics suitable for the sustained release of the material.

[0346] Fig. 8A2 shows the therapeutic device 100 implanted with the reservoir between the conjunctiva and the sclera, such that elongate structure 172 extends through the sclera to

20 couple the reservoir chamber to the vitreous humor. When implanted, the porous structure 150 can be located in the vitreous humor, or located between the conjunctiva and sclera, or may extend through the sclera, or combinations thereof.

[0347] Fig. 9 shows the porous structure 150 of therapeutic device 100 located in channel 174 near the opening to the chamber of the container 130. The porous structure can extend

25 substantially along the length of elongate structure 172.

[0348] Fig. 10 shows the porous structure 150 located within the chamber of container 150 and coupled to the first opening of the elongate structure 172 so as to provide the release rate profile. The porous structure can cover the opening of elongate structure 172 such that therapeutic amounts are released for the extended time as described herein.

[0349] Fig. 11 shows a plurality of injection ports spaced apart so as to inject and exchange the liquid of chamber of the container 130 and inject the therapeutic agent into the reservoir chamber of the container 130. The penetrable barrier 184 may comprise a first penetrable barrier located in a first access port formed in the barrier 160 and a second penetrable barrier  
5 located in a second access port formed in the barrier 160, and the first barrier can be separated from the second barrier by at least about 1 mm.

[0350] The injector 701 as described above can be configured to coupled to the reservoir placed between the conjunctiva and the sclera as describe herein. The injector 701 can be coupled to a double lumen needle 189L such that a second lumen 189B injects therapeutic  
10 agent 110 from a chamber 702C into device 100, and the first lumen can be spaced apart from the second lumen with the distance extending therebetween sized to position the first lumen in the first septum as described above and the second lumen in the second septum as described above. The second container 703C can be coupled to a first lumen 189A that extends to the chamber of the reservoir container and receives liquid from device 100, such that liquid of  
15 device 100 is exchanged when the chamber of the reservoir container is positioned between the conjunctiva and the sclera. The switching valve 703V to exchange an intended amount of liquid and an intended amount of the formulation the therapeutic agent 110, and inject an intended amount of therapeutic agent injected into device 100, for example such that a bolus amount of therapeutic agent can be injected from device 100 as described above. A portion of  
20 the formulation of therapeutic agent injected into device 100 can be retained in device 100 for release for an extended time.

[0351] The injector 701 can be used to exchange a liquid comprising a first therapeutic agent such as an antineoplastic agent, for example a VEGF inhibitor, and a second therapeutic agent such as a COX inhibitor, for example the ketorolac, such that the first and second therapeutic  
25 agent are injected together and exchanged with a liquid in the reservoir. The reservoir can be located between the sclera and the conjunctiva, or within the vitreous, or combinations thereof.

[0352] Fig. 12 shows the elongate structure 172 coupled to the container 130 away from the center of container 130 and near and located near an end of the container.

[0353] The first therapeutic device may comprise a device having the reservoir located in the  
30 vitreous humor and th second therapeutic device may comprise a device having the reservoir

located between the conjunctiva and the sclera, in accordance with embodiments as described herein.

[0354] The following examples are provided as non-limiting examples in accordance with embodiments of the present invention as described herein.

5 [0355] **EXAMPLE A- COMBINED TREATMENT WITH A FIRST ANTI-NEOPLASIA THERAPEUTIC AGENT AND A SECOND ANTIINFLAMMATORY THERAPEUTIC AGENT.**

[0356] A first therapeutic agent comprising an anti-neoplasia agent, such as an antineovascular agent, for example a VEGF inhibitor such as a Lucentis can be combined with  
10 an antiinflammatory, such as steroid comprising triamcinolone acetate. The release of triamcinolone acetate suspension is described supra in Examples 10 and 11 and corresponding Fig. 20. The first reservoir may comprise a volume of about 125 uL and an RRI of about 0.1 such that the first reservoir is tuned to receive a 50 uL injection of Lucentis and provide a concentration of about 3 ug/mL in the vitreous humor. The second reservoir may  
15 comprise Triamcinolone Acetonide having an RRI of 1.2, as described in Example 11, supra. The second reservoir may be configured in parallel or in series as described herein, and provide triamcinolone acetate for about 400 days over the course of at least 2 sequential 50 uL injections of Lucentis at day 0 and day 180, for example.

[0357] The amount of triamcinolone acetate suspension in the second chamber can be increased so as to comprise about a 20 uL reservoir volume loaded with 0.8 mg using a  
20 commercial drug product (40 mg/mL triamcinolone acetate), such that the triamcinolone acetate can be delivered in therapeutic amounts for an extended time of at least about 800 days, corresponding to about four sequential 50 uL injections of Lucentis™ at six month intervals. The IC<sub>50</sub> of triamcinolone can be about 1.5nM, depending on the target assay such  
25 as such as one or more of VEGF-induced cell proliferation, or receptor binding.

[0358] The amount of Ranibizumab in the first chamber can be increased, for example to about 2.5 mg, for example, such that the amount Ranibizumab delivered in therapeutic amounts for an extended time, and the RRI can be adjusted accordingly for example the RRI can be about 0.02 and provide about 10 ug/mL of Ranibizumab at about 6 months.

**[0359] EXAMPLE B: VEGF INHIBITORS COMBINED WITH COX INHIBITORS.**

**[0360]** A first therapeutic agent comprising an anti-neoplasia agent, such as an antineovascular agent, for example a VEGF inhibitor such as a Lucentis can be combined with a non-steroidal antiinflammatory, such as a COX inhibitor, for example comprising celecoxib.

5 The release of the small molecule cyclocoxib through the porous frit structure 150 can be similar to triamcinolone acetonide as described supra in Examples 10 and 11 and corresponding Fig. 20. The first reservoir may comprise a volume of about 125 uL and an RRI of about 0.1 such that the first reservoir is tuned to receive a 50 uL injection of Lucentis and provide a concentration of about 3 ug/mL in the vitreous humor. The second reservoir may comprise  
 10 solid celecoxib and have an RRI of 1.2, similar to that described in Example 11, supra. The second reservoir may be configured in parallel or in series as described herein, and provide therapeutic amounts of celecoxib.

**[0361]** The amount of celecoxib solid in the second chamber can be may be increased so as to provide therapeutic amounts of celecoxib for the extended time. Based on the teachings  
 15 described herein a person of ordinary skill in the art can determine the concentration of cyclocoxib in the vitreous humor to achieve therapeutic inhibition of COX for the treatment of one or more stages of AMD, and the RRI, reservoir volume and amount of solid can be determined. The IC50 of cyclocoxib can be approximately 40 nM, about 40 times less potent than triamcinolone acetonide. The celecoxib can be released from a separate chamber, for  
 20 example from a separate device, and the amount of celecoxib solid released from the separate device may comprise about 20 mg released over about 200 days, for example.

Table 3A. Examples of COX Inhibitors combined with the VEGF inhibitor Ranibizumab

Therapeutic Delivery Device

Parameters	celecoxib	ketorolac	bromfenac
RRI	3	<b>0.02</b>	5
volume(ul)/conc(mg/ml)	10/50	<b>25/175</b>	10/50
Constant delivery (days)	500	<b>180</b>	178

<b>Vitreous concentration</b>			
<b>(ug/ml)</b>	<b>0.13</b>	<b>0.9</b>	<b>0.1</b>
<b>IC50 (ug/ml) (Inhibitory Level)*</b>	<b>0.015</b>	<b>0.007</b>	<b>0.0025</b>

Table 3A shows examples of COX inhibitors that can be injected into the therapeutic device. The COX inhibitor may comprise celecoxib, keotolac or bromefenac. The RRIs, volumes and concentrations are shown to release therapeutic amounts for the times indicated time, and the vitreous concentrations are shown above the IC 50 concentrations.

Table 3B. Coefficients to determine ketorolac release rate profile.

Diffusion coeff (cm <sup>2</sup> /s)	5.0E-06
Solubility (ug/mL)	25000
Reservoir Vol (ml)	0.0250
PA/FL (RRI, mm)	0.02
Half-life (hr)	3
Rate constant, k (1/day)	5.545
Vitreous vol (ml)	4.5

Table 3C. Loading of Ketorolac to provide 318 days with a release rate of 21.6 ug/day and a vitreous concentration of 0.9 ug/mL

Diffusion coeff (cm <sup>2</sup> /s)	5.0E-06
Loading (mg/mL)	300.0
Solubility (mg/mL)	25.00
Reservoir Vol (ml)	0.025
Half-life (hr)	3
Rate constant, k (1/day)	5.545
Vitreous vol (ml)	4.5

Table. 3D Steady state release rate profile of Ketorolac suspension for 180 days.

PA/TL (mm)	Predicted Rate (ug/day)	Constant Rate Delivery Time (days)	Predicted Vitreous Conc (ug/mL)
0.02	21.6	318	0.9



Table. 3E. Ketorolac release profiles when injected Ketorolac comprises a solution.

Time (days)			Predicted Rate (ug/day)	Predicted %CR	Predicted Vitreous Conc (ug/mL)
0			21.6	0.0%	0.866
0.0833333			21.5	0.3%	0.863
0.1666667			21.5	0.6%	0.861
0.25			21.4	0.9%	0.858
0.3333333			21.4	1.1%	0.856
0.4166667			21.3	1.4%	0.853
0.5			21.2	1.7%	0.851
0.5833333			21.2	2.0%	0.848
0.6666667			21.1	2.3%	0.846
0.75			21.0	2.6%	0.843
0.8333333			21.0	2.8%	0.841
0.9166667			20.9	3.1%	0.839
1			20.9	3.4%	0.836
10			15.3	29.2%	0.613
20			10.8	49.9%	0.434
30			7.7	64.5%	0.307
40			5.4	74.9%	0.217
50			3.8	82.2%	0.154
60			2.7	87.4%	0.109
70			1.9	91.1%	0.077
80			1.4	93.7%	0.055
90			1.0	95.5%	0.039
100			0.7	96.8%	0.027
110			0.5	97.8%	0.019
120			0.3	98.4%	0.014
130			0.2	98.9%	0.010
140			0.2	99.2%	0.007

[0362] Based on the above tables, Ketorolac has an initial steady state release rate profile from the suspension for 318 days with a vitreous concentration of about 0.9 ug/mL, followed by release of the remain Ketorolac solution for about 70 days above about 0.07 ug/mL, for a total time above 0.07 of about 400 days. Based on the teachings described herein a person of ordinary skill in the art can determine many COX inhibitors suitable for release through the release mechanism with the antineoplastic agent such as the VEGF inhibitor, for example Lucentis.

[0363] The COX inhibitor can be combined with the VEGF inhibitor in the chamber of the therapeutic device and released together through the porous frit structure. The RRI of 0.02 shown for ketolac can be used with ranibizumab as described above, such that therapeutic amounts can be delivered for at least about 120 days, for example at least about 180 days. For example, the formulation may comprise Ranibizumab and ketorolac injected together into the therapeutic device. The values of RRI's and concentrations of Ranibizumab and volumes as described above are suitable for combination with a ketorolac suspension. The concentration of Ranibizumab in the formulation can be within the range from about 10 mg/ml to the upper limit of stable solubility of about 300 to 350 mg/mL. Additional VEGF inhibitors and COX inhibitors suitable for combination can be determined by one of ordinary skill in the art based on the teachings described herein.

[0364] Based on the teachings described herein, the vitreous half-life (clearance rate of the drug from the eye) is something that can be empirically determined. One of ordinary skill in the art could determine based upon similar MW to triamcinolone (celecoxib 381 vs. triamcinolone acetonide 394) and initially estimate the parameters to be the substantially same.

[0365] The IC<sub>50</sub> can be defined as the concentration of drug which leads to a 50% inhibition in a particular assay. For celecoxib, the IC<sub>50</sub> is approximately 15 ng/ml, corresponding to the minimum inhibitory concentration desired in the target tissue (retina, choroid). As a rough approximation, one could target above this concentration in the vitreous. The solubility of celecoxib in water is approximately 3ug/ml, so is this relatively "water insoluble" The solubility of triamcinolone acetonide is about 19 ug/mL measured at 37°C in 0.2 M potassium chloride and the diffusion coefficient of  $5 \times 10^{-6} \text{ cm}^2/\text{s}$  representative of a small molecule. The RRI for celecoxib can be about 600x the RRI for trimacinolone acetonide based on the above solubility and IC 50 data, for example an RRI of about 60.

[0366] Many amounts of Ranibizumab can be used, for example within a range from about 0.5 mg to about 10 mg, for example from about 1 mg to about 5 mg, for example from about 1.5 mg to about 3 mg, and the reservoir volume and release rate index can be sized based on the teaching described herein to proved the sustained release for the extended time. The amount of Ranibizumab in the chamber can be about 2 mg, for example, such that the amount Ranibizumab delivered in therapeutic amounts for an extended time, and the RRI can be

adjusted accordingly for example the RRI can be about 0.02 and provide about 10 ug/mL of Ranibizumab at least about 6 months.

## EXPERIMENTAL

[0367] Examples 1-4 (along with Examples 5-17C) are described in priority U.S. Provisional Pat. App. Ser. No. 61/371,168, filed 5 August 2010; U.S. App. Ser. No. 12/696,678, filed 5 January 29, 2010, entitled "Posterior Segment Drug Delivery", published as U.S. Pat. App. Pub. No. 2010/0255061 (attorney docket not. 026322-003750US); and PCT/US2010/022631, published 5 August 2010 as WO2010/088548, entitled "Posterior Segment Drug Delivery".

### **Example 5: Release of protein through a cylindrical sintered porous titanium cylinder**

10 [0368] Reservoirs were fabricated from syringes and sintered porous titanium cylinders (available from Applied Porous Technologies, Inc., Mott Corporation or Chand Eisenmann Metallurgical). These were sintered porous cylinders with a diameter of 0.062 inches and a thickness of 0.039 inches prepared from titanium particles. The porosity is 0.17 with mean pore sizes on the order of 3 to 5 micrometers. The porous cylinder is characterized as 0.2 media  
15 grade according to measurements of bubble point. The porous cylinders were press-fit into sleeves machined from Delrin. The sleeves exposed one entire planar face to the solution in the reservoir and the other entire planar face to the receiver solution in the vials, corresponding to an area of 1.9 square millimeters. The tips were cut off of 1 mL polypropylene syringes and machined to accept a polymer sleeve with outer diameter slightly larger than the inner diameter  
20 of the syringe. The porous cylinder / sleeve was press-fit into the modified syringe.

[0369] A solution was prepared containing 300 mg/mL bovine serum albumin (BSA, Sigma, A2153-00G) in phosphate buffered saline (PBS, Sigma, P3813). Solution was introduced into the syringes by removing the piston and dispensing approximately 200 microliters into the syringe barrel. Bubbles were tapped to the top and air was expressed out through the porous  
25 cylinder. Then BSA solution was expressed through the porous cylinder until the syringe held 100 uL as indicated by the markings on the syringe. The expressed BSA solution was wiped off and then rinsed by submerging in PBS. The reservoirs were then placed into 4 mL vials containing 2 mL PBS at room temperature. Collars cut from silicone tubing were placed around the syringe barrels to position the top of the reservoir to match the height of PBS. The silicone

tubing fit inside the vials and also served as a stopper to avoid evaporation. At periodic intervals, the reservoirs were moved to new vials containing PBS. The amount of BSA transported from the reservoir through the porous cylinder was determined by measuring the amount of BSA in the vials using a BCA<sup>TM</sup> Protein Assay kit (Pierce, 23227).

5 [0370] FIG. 13 shows the measured cumulative release of BSA through a sintered porous titanium disc and a prediction from the model describing release through a porous body. The Channel Parameter of 1.7 was determined via a least squares fit between the measured data and the model (MicroSoft Excel). Since the porous cylinder has equal areas exposed to the reservoir and receiving solution, the Channel Parameter suggests a tortuosity of 1.7 for porous titanium  
10 cylinders prepared from 0.2 media grade.

[0371] FIG. 13-1 shows the measured cumulative release of BSA of FIG. 13 measured to 180 days. The Channel Parameter of 1.6 was determined via a least squares fit between the measured data and the model (MicroSoft Excel). This corresponds to a Release Rate Index of 0.21 mm. Since the porous cylinder has equal areas exposed to the reservoir and receiving  
15 solution, the Channel Parameter corresponds to an effective path length channel parameter of 1.6 and suggests a tortuosity of 1.6 for porous titanium cylinders prepared from 0.2 media grade.

#### **Example 6: Release of protein through masked sintered porous titanium cylinders**

[0372] Reservoirs were fabricated from syringes and porous sintered titanium cylinders  
20 similar to that described in Example 5. The porous sintered titanium cylinders (available from Applied Porous Technologies, Inc., Mott Corporation or Chand Eisenmann Metallurgical) had a diameter of 0.082 inch, a thickness of 0.039 inch, a media grade of 0.2 and were prepared from titanium particles. The porosity is 0.17 with mean pore sizes on the order of 3 to 5 micrometers. The porous cylinder is characterized as 0.2 media grade according to  
25 measurements of bubble point. The porous cylinders were press fit into sleeves machined from Delrin. The sleeves exposed one entire planar face to the solution in the reservoir and the other entire planar face to the receiver solution in the vials, corresponding to an area of 3.4 square millimeters. The tips were cut off of 1 mL polycarbonate syringes and machined to accept a polymer sleeve with outer diameter slightly larger than the inner diameter of the syringe. The  
30 porous cylinder / sleeve was press fit into the modified syringe. A kapton film with adhesive

was affixed to the surface exposed to the receiving solution to create a mask and decrease the exposed area. In the first case, the diameter of the mask was 0.062 inches, exposing an area of 1.9 square millimeters to the receiving solution. In a second case, the diameter of the mask was 0.027 inches, exposing an area of 0.37 square millimeters.

5 [0373] Three conditions were run in this study: 1) 0.062 inch diameter mask, 100 uL donor volume, at room temperature in order to compare with reservoirs with unmasked porous cylinders in Example 5; 2) 0.062 inch diameter mask, 60 uL donor volume, at 37°C; and 3) 0.027 inch diameter mask, 60 uL donor volume, at 37°C. The syringes were filled with a solution containing 300 mg/mL bovine serum albumin (BSA, Sigma, A2153-00G) in phosphate  
10 buffered saline (Sigma, P3813), similar to Example 5. In addition, 0.02 wt% of sodium azide (Sigma, 438456-5G) was added as a preservative to both the BSA solution placed in the reservoirs and the PBS placed in the receiving vials and both solutions were filtered through a 0.2 micron filter. This time, the amount of BSA solution dispensed into the syringe was weighed and the amount expressed through the porous cylinder was determined by rinsing and  
15 measuring the amount of BSA in the rinse. Assuming unit density for the BSA solution, the amount dispensed was 113 +/- 2 uL (Condition 1) and 66 +/- 3 uL (Condition 2). Subtracting off the amount in the rinse yielded a final reservoir volume of 103 +/- 5 uL (Condition 1) and 58 +/- 2 uL (Condition 2). The reservoirs were then placed into 5 mL vials containing 1 mL PBS at 37°C in a heating block. At periodic intervals, the reservoirs were moved to new vials  
20 containing PBS and the BSA concentrations were determined in the receiving solutions using the method described in Example 5.

[0374] FIG. 14 shows the cumulative release of BSA protein through a masked sintered porous Titanium disc at Condition 1 (0.062 inch diameter mask, 100 uL donor volume, at room temperature) is faster than the release through an unmasked porous cylinder with the same  
25 exposed area (data from Example 5). Predictions are also shown using the Channel Parameter of 1.7 determined in Example 5, BSA diffusion coefficient at 20°C ( $6.1 \times 10^{-7} \text{ cm}^2/\text{s}$ ), reservoir volume of 100 uL, and the area of the porous cylinder exposed to the receiver solution ( $A=1.9 \text{ mm}^2$ ) or the area of the porous cylinder exposed to the reservoir ( $A=3.4 \text{ mm}^2$ ). The data for the masked porous cylinder matches more closely with larger area exposed to the reservoir. Hence,

this mask with width of 0.7 mm is not sufficient to reduce the effective area of the porous cylinder for the dimensions of this porous cylinder.

[0375] FIG. 15 shows the cumulative release of BSA protein through a masked sintered porous titanium cylinder at Condition 2 (0.062 inch diameter mask, 60 uL donor volume, at 5 37°C). The figure also displays predictions using the Channel Parameter of 1.7 determined in Example 5, BSA diffusion coefficient at 37°C ( $9.1 \times 10^{-7} \text{ cm}^2/\text{s}$ ), reservoir volume of 58 uL, and the area of the porous cylinder exposed to the receiver solution ( $A=1.9 \text{ mm}^2$ ) or the area of the porous cylinder exposed to the reservoir ( $A=3.4 \text{ mm}^2$ ). Again, the data for this masked porous cylinder matches more closely with larger area exposed to the reservoir. The consistency of the 10 data with the model at two temperatures supports how the model incorporates the effect of temperature.

[0376] FIG. 16 shows the cumulative release of BSA protein through a masked sintered porous titanium cylinder at Condition 3 (0.027 inch diameter mask, 60 uL donor volume, at 15 37°C). The figure also displays predictions using the Channel Parameter of 1.7 determined in Example 5, BSA diffusion coefficient at 37°C ( $9.1 \times 10^{-7} \text{ cm}^2/\text{s}$ ), reservoir volume of 58 uL, and the area of the porous cylinder exposed to the receiver solution ( $A=0.37 \text{ mm}^2$ ) or the area of the porous cylinder exposed to the reservoir ( $A=3.4 \text{ mm}^2$ ). This mask achieves a release rate corresponding to an effective area in between the area exposed to the reservoir and the area exposed to the receiver solution. A combination of the results in FIGS. 15 and 16 demonstrate 20 that slower release is achieved using a mask that exposes a smaller area to the receiver solution.

[0377] FIGS. 13-16 show an unexpected result. Masking of the area of the porous frit structure so as to decrease the exposed area of the porous structure decreased the release rate less than the corresponding change in area. The release rate through the porous structure corresponds substantially to the interconnecting channels of the porous frit structure disposed 25 between the first side exposed to the reservoir and the second side exposed to the receiver solution, such that the rate of release is maintained when a portion of the porous frit structure is covered. The rate of release of the interconnecting channels corresponds substantially to an effective area of the porous frit structure, and the effective area may correspond to an effective area of the interconnecting channels within the porous structure as shown above. As the rate of 30 release is dependent upon the interconnecting channels, the release rate can be maintained

when at least some of the channels are blocked, for example with coverage of a portion of the porous structure or blocking of a portion of the interconnecting channels with particles.

**Example 7: Release of protein through sintered porous stainless steel cylinder (media grade 0.1)**

5 [0378] Prototype devices were fabricated from tubing and sintered porous stainless steel cylinders (available from Applied Porous Technologies, Inc., Mott Corporation or Chand Eisenmann Metallurgical) which are cylindrical with diameter 0.155 inch and thickness 0.188 inch prepared from 316L stainless steel particles. The porous cylinder is characterized as 0.1 media grade according to measurements of bubble point. This study was performed with these  
10 large, off-the-shelf porous cylinders with an area of 12 mm<sup>2</sup> in order to characterize the resistive properties of 0.1 media grade stainless steel.

[0379] These devices were prepared using Teflon-FEP heat shrink tubing (Zeus, #37950) and a hot air gun to shrink around the porous cylinders on one end and a custom prepared septum on the other end (Nusil MED1 4013 silicone molded to 0.145 inch diameter). The reservoir  
15 volume (46 +/- 2 uL) was determined from the difference in weight between empty systems and systems loaded with PBS. The PBS was loaded by submerging the systems in PBS and drawing a vacuum. The systems were then sterilized by heating to 250°F, 15 psi for 15 minutes, submerged in PBS in microcentrifuge tubes placed in a pressure cooker (Deni, 9760). Two 30G needles were inserted into the septum to displace the PBS with BSA solution. One was used to  
20 inject the BSA solution and the other was bent and used as a vent for the displaced PBS. Sufficient BSA solution was injected to fill the needle hub of the vent to approximately ¾ full. Similar to Example 6, the BSA and PBS contained sodium azide and the nominal concentration was 300 mg/mL BSA. The devices were placed into 1.5 mL microcentrifuge tubes containing 1 mL PBS and kept at 37°C in a heating block. Pieces of silicone tubing (tight  
25 fit with inside of tube, hole for septum) were used to suspend the devices in the PBS with the bottom of the septum approximately the same height as the PBS. The concentrations in the first tubes contained BSA from the filling process and were discarded. At periodic intervals, the devices were moved to new tubes containing PBS and the BSA concentrations were determined in the receiving solutions using the method described in Example 5.

[0380] FIG. 17 displays the measured cumulative release of BSA through the 0.1 media grade stainless steel sintered titanium discs. Since the Porosity, P, is not available from the vendor at this time, a single parameter of Porosity divided by Channel Parameter was determined by least squares fit of the model to the data. Since the sintered porous structure is cylindrical, the Channel Parameter can be interpreted as the Tortuosity, T, and P/T was determined to be equal to 0.07.

**Example 8: Release of protein through a sintered porous stainless steel cylinder (media grade 0.2)**

[0381] Prototype devices were fabricated from tubing and sintered porous stainless steel cylinders (available from Applied Porous Technologies, Inc., Mott Corporation or Chand Eisenmann Metallurgical) which are cylindrical with diameter 0.031 inch, and thickness 0.049 inch prepared from 316L stainless steel particles. The porous cylinder is characterized as 0.2 media grade according to measurements of bubble point. This porous cylinder was obtained as a custom order with properties determined from a previous study with a large diameter 0.2 media grade porous stainless steel cylinder (data not shown) and predictions based on the model described herein. The area of each face of this porous cylinder is 0.5 mm<sup>2</sup>.

[0382] These devices were prepared using Teflon-FEP heat shrink tubing (Zeus, 0.125 inch OD) and a hot air gun to shrink around the porous cylinder on one end and a custom prepared septum on the other end (Nusil MED1 4013 silicone molded to 0.113 inch diameter). The reservoir volume (17 +/- 1 uL) was determined from the difference in weight between empty systems and systems filled with PBS. The PBS was loaded by submerging the systems in PBS and drawing a vacuum. Dry devices were submerged in PBS in microcentrifuge tubes and sterilized by heating to 250°F, 15 psi for 15 minutes in a pressure cooker (Deni, 9760). Two 30G needles were inserted into the septum to fill the devices with PBS. One was used to inject the PBS and the other was bent and used as a vent. After weighing the PBS filled devices, two new needles were inserted through the septum and sufficient BSA solution was injected to fill the needle hub of the vent to approximately ¾ full. The remaining details of the experiment are the same as Example 7.

[0383] FIG. 18A displays the measured cumulative release of BSA through the 0.2 media grade sintered porous stainless steel cylinder. A single parameter of Porosity divided by



Channel Parameter was determined to be 0.12 by least squares fit of the model to the data. Since the sintered porous structure is cylindrical, the Channel Parameter can be interpreted as effective length of the interconnecting channels that may correspond the Tortuosity, T. Using the Porosity of 0.17 determined by the vendor, the effective length of the channel that may correspond to the Tortuosity was determined to be 1.4. Furthermore, this corresponds to a PA/FL ratio (Release Rate Index) of 0.0475 mm.

[0384] FIG. 18B displays the measured cumulative release of BSA through the 0.2 media grade sintered porous stainless steel cylinder for 180 days. A single parameter of Porosity divided by Channel Parameter was determined to be 0.10 by least squares fit of the model to the data. Since the sintered porous structure is cylindrical, the Channel Parameter can be interpreted an effective length of the inter-connecting channels that may correspond to the Tortuosity, T. Using the Porosity of 0.17 determined by the vendor, the effective channel length of the inter-connecting channels that may correspond to the Tortuosity was determined to be 1.7. Furthermore, this corresponds to a PA/FL ratio (Release Rate Index) of 0.038 mm.

#### 15 **Example 9: Calculations of Lucentis™ concentrations in the vitreous**

[0385] The vitreous concentrations of a therapeutic agent can be predicted based on the equations described herein. Table 4 shows the values of the parameters applied for each of Simulation 1, Simulation 2, Simulation 3, Simulation 4, and Simulation 5. The half-life and vitreous volume correspond to a monkey model (J. Gaudreault et al., Preclinical Pharmacokinetics of Ranibizumab (rhuFabV2) after a Single Intravitreal Administration, Invest Ophthalmol Vis Sci 2005; 46: 726-733) (Z. Yao et al., Prevention of Laser Photocoagulation Induced Choroidal Neovascularization Lesions by Intravitreal Doses of Ranibizumab in Cynomolgus Monkeys, ARVO 2009 abstract D906). The parameter PA/FL can be varied to determine the release rate profile. For example, the value of A can be about  $1 \text{ mm}^2$ , the porosity can be about 0.1 ( $PA=0.1 \text{ mm}^2$ ) and the length about 1 mm and the channel fit parameter that may correspond to tortuosity can be about 2 ( $FL=2 \text{ mm}$ ), such that PA/TL is about 0.05 mm. A person of ordinary skill in the art can determine empirically the area, porosity, length and channel fit parameter for extended release of the therapeutic agent for the extended period based on the teachings described herein.

Table 4A.

Parameter	Values Simulation 1	Values Simulation 2	Values Simulation 3	Values Simulation 4	Values Simulation 5
Diffusion coeff (cm <sup>2</sup> /s)	1.0E-06	1.0E-06	1.0E-06	1.0E-06	1.0E-06
Initial Loading (ug/mL)	10000	10000	10000	10000	10000
Reservoir Vol (ml)	0.05	0.01	0.05	0.01	0.017
PA/FL (mm)	0.0225	0.0225	0.045	0.045	0.047
Half-life (days)	2.63	2.63	2.63	2.63	2.63
Rate constant, k (1/day)	0.264	0.264	0.264	0.264	0.264
Vitreous vol (ml)	1.5	1.5	1.5	1.5	1.5

[0386] Table 4B shows the vitreous concentrations calculated for a 0.5 mg bolus injection of Lucentis<sup>TM</sup> injected into the eye of a monkey using equations described herein and the half-life measured for the monkey listed in Table 4A. The first column used the measured C<sub>max</sub> (Gaudreault et al.) while the second used a calculated C<sub>max</sub> based on the dose and volume of the vitreous. The average concentration of Lucentis<sup>TM</sup> is about 46 ug/ml. The minimum therapeutic concentration of Lucentis<sup>TM</sup> is about 0.1 ug/mL, which may correspond to about 100% VEGF inhibition (Gaudreault et al.). Table 4B indicates that a bolus injection of 0.5 mg Lucentis<sup>TM</sup> maintains a vitreous concentration above 0.1 ug/mL for about a month whether using the measured or calculated C<sub>max</sub>. This is consistent with monthly dosing that has been shown to be therapeutic in clinical studies.

Table 4B.

Time (days)	Predicted Vitreous Conc using Meas Cmax (ug/mL)	Predicted Vitreous Conc using Calc Cmax (ug/mL)
0	169.00	333.33
1	129.85	256.11
2	99.76	196.77
3	76.65	151.18
4	58.89	116.16
5	45.25	89.24
6	34.76	68.57
7	26.71	52.68
8	20.52	40.48
9	15.77	31.10
10	12.11	23.89
11	9.31	18.36
12	7.15	14.10
13	5.49	10.84
14	4.22	8.33
15	3.24	6.40
16	2.49	4.91
17	1.91	3.78
18	1.47	2.90
19	1.13	2.23
20	0.87	1.71
21	0.67	1.32
22	0.51	1.01
23	0.39	0.78
24	0.30	0.60
25	0.23	0.46
26	0.18	0.35
27	0.14	0.27
28	0.11	0.21
29	0.08	0.16
30	0.06	0.12
31	0.05	0.09
32	0.04	0.07

[0387] Tables 4C1, 4C2, 4C3 4C4, and 4C5 show the calculated concentration of Lucentis™ in the vitreous humor for Simulation 1, Simulation 2, Simulation 3, Simulation 4, and Simulation 5 respectively. These results indicate Lucentis™ vitreous concentrations may be maintained above the minimum therapeutic level for about a year or more when released from a device with porous structure characterized by PA/FL  $\leq 0.0225$  mm and a reservoir volume  $\geq 10$  uL.

[0388] Simulation 5 corresponds to the devices used in the experiment described in Example 8. This device had a reservoir volume of 17 uL and porous structure characterized by  $PA/FL = 0.047$  mm. When this device is loaded with Lucentis<sup>TM</sup>, the loading dose corresponds to 1/3 of the 50 uL currently injected monthly. Calculations that predict vitreous concentrations indicate  
5 that this device with one-third of the monthly dose may maintain Lucentis<sup>TM</sup> therapeutic concentrations for about 6 months. While half of the dose is delivered in the first month and more than 98% delivered at 6 months, therapeutic levels may still be maintained for 6 months.

[0389] The ability of the device to release therapeutic agent for an extended time can be described by an effective device half-life. For the device in Example 8, the effective device  
10 half-life is 29 days for delivery of Lucentis<sup>TM</sup>. The device can be configured by selection of the reservoir volume and a porous structure with an appropriate PA/FL to achieve the desired effective half-life.

Table 4C1

<b>Simulation 1</b>			
<b>Time (days)</b>	<b>Predicted Rate (ug/day)</b>	<b>Predicted %CR</b>	<b>Predicted Vitreous Conc (ug/mL)</b>
0	1.9	0.0%	4.9
10	1.9	3.8%	4.7
20	1.8	7.5%	4.5
30	1.7	11.0%	4.4
40	1.7	14.4%	4.2
50	1.6	17.7%	4.0
60	1.5	20.8%	3.9
70	1.5	23.8%	3.7
80	1.4	26.7%	3.6
90	1.4	29.5%	3.5
100	1.3	32.2%	3.3
110	1.3	34.8%	3.2
120	1.2	37.3%	3.1
130	1.2	39.7%	3.0
140	1.1	42.0%	2.9
150	1.1	44.2%	2.7
160	1.0	46.3%	2.6
170	1.0	48.4%	2.5
180	1.0	50.3%	2.4
190	0.9	52.2%	2.3
200	0.9	54.0%	2.3
210	0.9	55.8%	2.2
220	0.8	57.5%	2.1
230	0.8	59.1%	2.0
240	0.8	60.7%	1.9
250	0.7	62.2%	1.9
260	0.7	63.6%	1.8
270	0.7	65.0%	1.7
280	0.7	66.3%	1.7
290	0.6	67.6%	1.6
300	0.6	68.9%	1.5
310	0.6	70.0%	1.5
320	0.6	71.2%	1.4
330	0.5	72.3%	1.4
340	0.5	73.3%	1.3
350	0.5	74.4%	1.3
360	0.5	75.3%	1.2

Table 4C2

Simulation 2			
Time (days)	Predicted Rate (ug/day)	Predicted %CR	Predicted Vitreous Conc (ug/mL)
0	1.9	0.0%	4.92
10	1.6	17.7%	4.05
20	1.3	32.2%	3.33
30	1.1	44.2%	2.74
40	0.9	54.0%	2.26
50	0.7	62.2%	1.86
60	0.6	68.9%	1.53
70	0.5	74.4%	1.26
80	0.4	78.9%	1.04
90	0.3	82.6%	0.85
100	0.3	85.7%	0.70
110	0.2	88.2%	0.58
120	0.2	90.3%	0.48
130	0.2	92.0%	0.39
140	0.1	93.4%	0.32
150	0.1	94.6%	0.27
160	0.1	95.5%	0.22
170	0.1	96.3%	0.18
180	0.1	97.0%	0.15
190	0.0	97.5%	0.12
200	0.0	98.0%	0.10
210	0.0	98.3%	0.08
220	0.0	98.6%	0.07
230	0.0	98.9%	0.06
240	0.0	99.1%	0.05
250	0.0	99.2%	0.04
260	0.0	99.4%	0.03
270	0.0	99.5%	0.03
280	0.0	99.6%	0.02
290	0.0	99.6%	0.02
300	0.0	99.7%	0.01
310	0.0	99.8%	0.01
320	0.0	99.8%	0.01
330	0.0	99.8%	0.01
340	0.0	99.9%	0.01
350	0.0	99.9%	0.01
360	0.0	99.9%	0.00

Table 4C3

Simulation 3			
Time (days)	Predicted Rate (ug/day)	Predicted %CR	Predicted Vitreous Conc (ug/mL)
0	3.9	0.0%	9.8
10	3.6	7.5%	9.1
20	3.3	14.4%	8.4
30	3.1	20.8%	7.8
40	2.8	26.7%	7.2
50	2.6	32.2%	6.7
60	2.4	37.3%	6.2
70	2.3	42.0%	5.7
80	2.1	46.3%	5.3
90	1.9	50.3%	4.9
100	1.8	54.0%	4.5
110	1.7	57.5%	4.2
120	1.5	60.7%	3.9
130	1.4	63.6%	3.6
140	1.3	66.3%	3.3
150	1.2	68.9%	3.1
160	1.1	71.2%	2.8
170	1.0	73.3%	2.6
180	1.0	75.3%	2.4
190	0.9	77.2%	2.2
200	0.8	78.9%	2.1
210	0.8	80.5%	1.9
220	0.7	81.9%	1.8
230	0.7	83.3%	1.6
240	0.6	84.5%	1.5
250	0.6	85.7%	1.4
260	0.5	86.8%	1.3
270	0.5	87.7%	1.2
280	0.4	88.7%	1.1
290	0.4	89.5%	1.0
300	0.4	90.3%	1.0
310	0.3	91.0%	0.9
320	0.3	91.7%	0.8
330	0.3	92.3%	0.8
340	0.3	92.9%	0.7
350	0.3	93.4%	0.6
360	0.2	93.9%	0.6

Table 4C4

<b>Simulation 4</b>			
<b>Time (days)</b>	<b>Predicted Rate (ug/day)</b>	<b>Predicted %CR</b>	<b>Predicted Vitreous Conc (ug/mL)</b>
0	3.89	0.0%	9.83
10	2.64	32.2%	6.67
20	1.79	54.0%	4.52
30	1.21	68.9%	3.06
40	0.82	78.9%	2.08
50	0.56	85.7%	1.41
60	0.38	90.3%	0.95
70	0.26	93.4%	0.65
80	0.17	95.5%	0.44
90	0.12	97.0%	0.30
100	0.08	98.0%	0.20
110	0.05	98.6%	0.14
120	0.04	99.1%	0.09
130	0.02	99.4%	0.06
140	0.02	99.6%	0.04
150	0.01	99.7%	0.03
160	0.01	99.8%	0.02
170	0.01	99.9%	0.01
180	0.00	99.9%	0.01
190	0.00	99.9%	0.01
200	0.00	100.0%	0.00
210	0.00	100.0%	0.00
220	0.00	100.0%	0.00
230	0.00	100.0%	0.00
240	0.00	100.0%	0.00
250	0.00	100.0%	0.00
260	0.00	100.0%	0.00
270	0.00	100.0%	0.00
280	0.00	100.0%	0.00
290	0.00	100.0%	0.00
300	0.00	100.0%	0.00
310	0.00	100.0%	0.00
320	0.00	100.0%	0.00
330	0.00	100.0%	0.00
340	0.00	100.0%	0.00
350	0.00	100.0%	0.00
360	0.00	100.0%	0.00



Table 4C5

<b>Simulation 5</b>			
<b>Time (days)</b>	<b>Predicted Rate (ug/day)</b>	<b>Predicted %CR</b>	<b>Predicted Vitreous Conc (ug/mL)</b>
0	4.1	0.0%	10.27
10	3.2	21.2%	8.09
20	2.5	38.0%	6.37
30	2.0	51.2%	5.02
40	1.6	61.5%	3.95
50	1.2	69.7%	3.11
60	1.0	76.1%	2.45
70	0.8	81.2%	1.93
80	0.6	85.2%	1.52
90	0.5	88.3%	1.20
100	0.4	90.8%	0.94
110	0.3	92.8%	0.74
120	0.2	94.3%	0.58
130	0.2	95.5%	0.46
140	0.1	96.5%	0.36
150	0.1	97.2%	0.29
160	0.1	97.8%	0.22
170	0.1	98.3%	0.18
180	0.1	98.6%	0.14
190	0.0	98.9%	0.11
200	0.0	99.2%	0.09
210	0.0	99.3%	0.07
220	0.0	99.5%	0.05
230	0.0	99.6%	0.04
240	0.0	99.7%	0.03
250	0.0	99.7%	0.03
260	0.0	99.8%	0.02
270	0.0	99.8%	0.02
280	0.0	99.9%	0.01
290	0.0	99.9%	0.01
300	0.0	99.9%	0.01
310	0.0	99.9%	0.01
320	0.0	100.0%	0.00
330	0.0	100.0%	0.00
340	0.0	100.0%	0.00
350	0.0	100.0%	0.00
360	0.0	100.0%	0.00

[0390] Z. Yao et al. (Prevention of Laser Photocoagulation Induced Choroidal Neovascularization Lesions by Intravitreal Doses of Ranibizumab in Cynomolgus Monkeys, ARVO 2009 abstract D906) have performed a preclinical study to determine the lowest efficacious Lucentis™ dose in cynomolgus monkeys that leads to 100% prevention of laser photocoagulation treatment-induced Grade IV choroidal neovascularization (CNV) lesions.™  
5 This model has been shown to be relevant to AMD. Intravitreal injection of Lucentis™ at all doses tested completely inhibited the development of Grade IV CNV lesions. Table 4D shows predictions of Lucentis™ vitreous concentrations for the lowest total amount of Lucentis™ investigated (intravitreal injection of 5 ug on days 1, 6, 11, 16, 21 and 26), using the equations  
10 described herein and pharmacokinetic parameters listed in Table 4A. This data indicates that it is not necessary to achieve the high Cmax of a 0.5 mg single bolus injection in order to be therapeutic.

[0391] FIG. 19A compares this predicted profile with that predicted for the device in Example 8. This data further supports that the release profile from a device in accordance with  
15 embodiments of the present invention may be therapeutic for at least about 6 months. The single injection of 500 ug corresponds to a 50 uL bolus injection of Lucentis™ that can given at monthly intervals, and the range of therapeutic concentrations of Lucentis™ (ranibizumab) in the vitreous extends from about 100 ug/mL to the minimum inhibitory (therapeutic) concentration of about 0.1 ug/mL at about 1 month, for example. The minimum inhibitory  
20 concentration corresponding to the lower end of the range of therapeutic concentrations in the vitreous humor can be determined empirically by one of ordinary skill in the art in accordance with the examples described herein. For example, a lose does study of a series of six Lucentis™ injections, 5 ug each, can be administered so as to provide a concentration in the vitreous of at least about 1 ug/mL, and the therapeutic benefit of the injections assessed as  
25 described herein.

Table 4D

<b>Time (days)</b>	<b>Predicted Lucentis Vitreous Conc (ug/mL)</b>
0	0.00
1	3.33
2	2.56
3	1.97
4	1.51
5	1.16
6	4.23
7	3.25
8	2.49
9	1.92
10	1.47
11	4.46
12	3.43
13	2.64
14	2.02
15	1.56
16	4.53
17	3.48
18	2.67
19	2.05
20	1.58
21	4.55
22	3.49
23	2.68
24	2.06
25	1.58
26	4.55
27	3.50
28	2.69
29	2.06
30	1.59
35	0.42
40	0.11
45	0.03
50	0.01
60	0.00
70	0.00
80	0.00
90	0.00

[0392] The concentration profiles of a therapeutic agent comprising Lucentis™ were determined as shown below based on the teachings described herein and with drug half-life of nine days for Lucentis™ in the human eye. The examples shown below for injections of the commercially available formulation Lucentis™ and the nine day half life show unexpected results, and that a volume of formulation corresponding to a monthly bolus injection into the device as described herein can provide therapeutic benefit for at least about two months. The device volume and the porous structure can be tuned to receive the predetermined volume of formulation and provide sustained release for an extended time. Additional tuning of the device can include the half-life of the therapeutic agent in the eye, for example nine days for Lucentis™, and the minimum inhibitory concentration of the therapeutic agent as determined based on the teachings as described herein.

[0393] FIG. 19B shows determined concentrations of Lucentis™ in the vitreous humor for a first 50 uL injection into a 25 uL device and a second 50 uL injection at 90 days. The calculations show that the 50 uL dosage of the monthly FDA approved bolus injection can be used to treat the eye for about 90 days, and that the injections can be repeated to treat the eye, for example at approximately 90 day intervals. The Lucentis™ may comprise a predetermined amount of the commercially available formulation injected into the device. The commercially available formulation of Lucentis™ has a concentration of ranibizumab of 10 mg/mL, although other concentrations can be used for example as described herein below with reference to a 40 mg/mL solution of injected ranibizumab. The predetermined amount corresponds to the amount of the monthly bolus injection, for example 50 uL. The therapeutic device may comprise a substantially fixed volume container reservoir having a volume of 25 uL, such that a first 25 uL portion of the 50 uL injection is contained in the reservoir for sustained and/or controlled release and a second 25 uL portion of the 50 uL injection is passed through the porous structure and released into the vitreous with a 25 uL bolus. The filling efficiency of the injection into the device may comprise less than 100%, and the reservoir volume and injection volume can be adjusted based on the filling efficiency in accordance with the teachings described herein. For example, the filling efficiency may comprise approximately 90%, such that the first portion comprises approximately 22.5 uL contained in the chamber of the container reservoir and the second portion comprises approximately 27.5 uL passed through the device for the 50 uL injected into the therapeutic device. The initial concentration of Lucentis™ in the vitreous

humor corresponds to about 60 ug/mL immediately following injection into the reservoir device. The concentration of Lucentis™ in the vitreous humor decreases to about 3.2 ug/mL at 90 days. A second 50 uL injection of Lucentis™ approximately 90 days after the first injection increases the concentration to about 63 ug/mL. The concentration of Lucentis™ in the vitreous humor decreases to about 3.2 ug/mL at 180 days after the first injection and 90 days after the second injection. These calculations show that the concentration of Lucentis™ can be continuously maintained above a minimum inhibitory concentration of about 3 ug per ml with the 50 uL injection into the device. Additional injections can be made, for example every 90 days for several years to deliver the therapeutic agent to treat the patient.

10 [0394] FIG. 19C shows determined concentrations of Lucentis™ in the vitreous humor for a first 50 uL injection into a 32 uL device and a second 50 uL injection at a time greater than 90 days. The calculations show that the 50 uL dosage of the monthly FDA approved bolus injection can be used to treat the eye for about 90 days, and that the injections can be repeated to treat the eye, for example at approximately 90 day intervals. The Lucentis™ may comprise a predetermined amount of the commercially available formulation injected into the device. The predetermine amount corresponds to the amount of the monthly bolus injection, for example 50 uL. The therapeutic device may comprise a substantially fixed volume container reservoir having a volume of 32 uL, such that a first 32 uL portion of the 50 uL injection is contained in the reservoir for sustained and/or controlled release and a second 18 uL portion of the 50 uL injection is passed through the porous structure and released into the vitreous with an 18 uL bolus. The filling efficiency of the injection into the device may comprise less than 100%, and the reservoir volume and injection volume can be adjusted based on the filling efficiency in accordance with the teachings described herein. For example, the filling efficiency may comprise approximately 90%, such that the first portion comprises approximately 29 uL contained in the chamber of the reservoir container and the second portion comprises approximately 21 uL passed through the device for the 50 uL of Lucentis™ injected into the therapeutic device. The initial concentration of Lucentis™ in the vitreous humor corresponds to about 45 ug/mL immediately following injection into the reservoir device. The concentration of Lucentis™ in the vitreous humor decreases to about 4 ug/mL at 90 days. A second 50 uL injection of Lucentis™ approximately 90 days after the first injection increases the concentration to about 50 ug/ mL. The concentration of Lucentis™ in the vitreous humor

decreases to about 4 ug/mL at 180 days after the first injection and 90 days after the second injection. These calculations show that the concentration of Lucentis™ can be continuously maintained above a minimum inhibitory concentration of about 4 ug per ml with the 50 uL injection into the device. Additional injections can be made every 120 days for several years to  
5 deliver the therapeutic agent to treat the patient. The injections can be made more frequently or less frequently, depending upon the minimum inhibitory concentration, the release rate profile, and the discretion of the treating physician.

[0395] FIG. 19D shows determined concentrations of Lucentis™ in the vitreous humor for a first 50 uL injection into a 50 uL device and a second 50 uL injection at 90 days. The  
10 calculations show that the 50 uL dosage of the monthly FDA approved bolus injection can be used to treat the eye for about 90 days, and that the injections can be repeated to treat the eye, for example at approximately 90 day intervals. The Lucentis™ may comprise a predetermined amount of the commercially available formulation injected into the device. The filling efficiency of the injection into the device may comprise less than 100%, and the reservoir  
15 volume and injection volume can be adjusted based on the filling efficiency in accordance with the teachings described herein. For example, the filling efficiency may comprise approximately 90%, such that the first portion comprises approximately 45 uL contained in the chamber of the reservoir container and the second portion comprises approximately 5 uL passed through the device for the 50 uL of Lucentis™ injected into the therapeutic device. The  
20 initial concentration of Lucentis™ in the vitreous humor corresponds to about 11 ug/mL immediately following injection into the reservoir device. The concentration of Lucentis™ in the vitreous humor decreases to about 5.8 ug/mL at 90 days. A second 50 uL injection of Lucentis™ approximately 90 days after the first injection increases the concentration to about 17 ug/ mL. The concentration of Lucentis™ in the vitreous humor decreases to about 5,8  
25 ug/mL at 180 days after the first injection and 90 days after the second injection. These calculations show that the concentration of Lucentis™ can be continuously maintained above a minimum inhibitory concentration of about 5 ug per ml with the 50 uL injection into the device. Additional injections can be made, for example every 90 days for several years to deliver the therapeutic agent to treat the patient.

[0396] FIG. 19E shows determined concentrations of Lucentis™ in the vitreous humor for a first 50 uL injection into a 50 uL device and a second 50 uL injection at 90 days. The calculations show that the 50 uL dosage of the monthly FDA approved bolus injection can be used to treat the eye for about 130 days, and that the injections can be repeated to treat the eye, for example at approximately 120 day intervals. The Lucentis™ may comprise a predetermined amount of the commercially available formulation injected into the device. The filling efficiency of the injection into the device may comprise less than 100%, and the reservoir volume and injection volume can be adjusted based on the filling efficiency in accordance with the teachings described herein. For example, the filling efficiency may comprise approximately 90%, such that the first portion comprises approximately 45 uL contained in the chamber of the reservoir container and the second portion comprises approximately 5 uL passed through the device for the 50 uL of Lucentis™ injected into the therapeutic device. The initial concentration of Lucentis™ in the vitreous humor corresponds to about 11 ug/mL immediately following injection into the reservoir device. The concentration of Lucentis™ in the vitreous humor decreases to about 4 ug/mL at 133 days. A second 50 uL injection of Lucentis™ approximately 130 days after the first injection increases the concentration to about 15 ug/mL. Based on these calculations, the concentration of Lucentis™ in the vitreous humor decreases to about 4 ug/mL at 266 days after the first injection and 90 days after the second injection. These calculations show that the concentration of Lucentis™ can be continuously maintained above a minimum inhibitory concentration of about 4 ug per ml with the 50 uL injection into the device. Additional injections can be made, for example every 90 days for several years to deliver the therapeutic agent to treat the patient.

[0397] Although FIGS. 19B to 19P make reference to injections of commercially available off the shelf formulations of Lucentis™, therapeutic device 100 can be similarly configured to release many formulations of the therapeutic agents as described herein, for example with reference to Table 1A and the Orange Book of FDA approved formulations and similar books of approved drugs in many countries, unions and jurisdictions such as the European Union. For example, based on the teachings described herein, one can determine empirically the parameters of therapeutic device 100 so as to tune the device to receive a injection of a commercially available formulation corresponding to a monthly bolus injections and release the injected therapeutic agent with amounts above the minimum inhibitory concentration for an

extended time of at least about two months, for example, at least about three months, for example, or about four months, for example.

[0398] FIG. 19F shows determined concentrations of ranibizumab in the vitreous humor for a 50 uL Lucentis<sup>TM</sup> injection into a 50 uL device having a release rate index of 0.05. The concentration of ranibizumab in the vitreous humor peaks at around 9 ug/mL and is at or above 4 ug/mL for about 145 days. The concentration remains above about 1 ug/mL for about 300 days. The concentration is about 0.6 ug/mL at 360 days, and can be suitable for treatment with a single injection up to one year, based on a minimum inhibitory concentration of about 0.5. The minimum inhibitory concentration can be determined empirically by a person of ordinary skill in the art based on the teachings described herein.

[0399] FIG. 19G shows determined concentrations of ranibizumab in the vitreous humor for a 50 uL Lucentis<sup>TM</sup> injection into a 75 uL device having a release rate index of 0.05. The concentration of ranibizumab in the vitreous humor peaks at around 6.5 ug/mL and is at or above 4 ug/mL for about 140 days. The concentration remains above about 1 ug/mL for about 360 days.

[0400] FIG. 19H shows determined concentrations of ranibizumab in the vitreous humor for a 50 uL Lucentis<sup>TM</sup> injection into a 100 uL device having a release rate index of 0.05. The concentration of ranibizumab in the vitreous humor peaks at around 5 ug/mL and is at or above 4 ug/mL for about 116 days. The concentration remains above about 1 ug/mL for more than 360 days and is about 1.5 ug/mL at 360 days.

[0401] FIG. 19I shows determined concentrations of ranibizumab in the vitreous humor for a 50 uL Lucentis<sup>TM</sup> injection into a 125 uL device having a release rate index of 0.05. The concentration of ranibizumab in the vitreous humor peaks at around 4.3 ug/mL and does not equal or exceed 4 ug/mL. The concentration remains above about 1 ug/mL for more than 360 days and is about 1.5 ug/mL at 360 days.

[0402] FIG. 19J shows determined concentrations of ranibizumab in the vitreous humor for a 50 uL Lucentis<sup>TM</sup> injection into a 150 uL device having a release rate index of 0.05. The concentration of ranibizumab in the vitreous humor peaks at around 3.5 ug/mL and does not



equal or exceed 4 ug/mL. The concentration remains above about 1 ug/mL for more than 360 days and is about 1.5 ug/mL at 360 days.

[0403] FIG. 19K shows determined concentrations of ranibizumab in the vitreous humor for a 50 uL Lucentis™ injection into a 100 uL device having a release rate index of 0.1. These  
5 determined concentrations are similar to the determined concentrations of FIG. 19F, and show that the release rate index of the porous structure can be tuned with the device volume to provide therapeutic concentration profile for an extended time. For example, by doubling the volume of the reservoir so as to half the concentration of therapeutic agent in the vitreous, the release rate index can be doubled so as to provide a similar therapeutic concentration profile.  
10 The concentration of ranibizumab in the vitreous humor peaks at around 9 ug/mL and is at or above 4 ug/mL for about 145 days. The concentration remains above about 1 ug/mL for about 300 days. The concentration is about 0.6 ug/mL at 360 days.

[0404] FIGS. 19L to 19P show examples of release rate profiles with 125 uL reservoir devices having the RRI vary from about 0.065 to about 0.105, such that these devices are tuned  
15 to receive the 50 uL injection of Lucentis™ and provide sustained release above a minimum inhibitory concentration for at least about 180 days. These calculations used a drug half life in the vitreous of 9 days to determine the profiles and 100% efficiency of the injection.

[0405] FIG. 19L shows determined concentration profiles of ranibizumab in the vitreous humor for a 50 uL Lucentis™ injection into a 125 uL reservoir device having a release rate  
20 index of 0.105. The concentration of ranibizumab in the vitreous at 180 days is about 3.128 ug/mL.

[0406] FIG. 19M shows determined concentration profiles of ranibizumab in the vitreous humor for a 50 uL Lucentis™ injection into a 125 uL reservoir device having a release rate  
25 index of 0.095. The concentration of ranibizumab in the vitreous at 180 days is about 3.174 ug/mL.

[0407] FIG. 19N shows determined concentration profiles of ranibizumab in the vitreous humor for a 50 uL Lucentis™ injection into a 125 uL reservoir device having a release rate  
index of 0.085. The concentration of ranibizumab in the vitreous at 180 days is about 3.185 ug/mL.

[0408] FIG. 19O shows determined concentration profiles of ranibizumab in the vitreous humor for a 50 uL Lucentis™ injection into a 125 uL reservoir device having a release rate index of 0.075. The concentration of ranibizumab in the vitreous at 180 days is about 3.152 ug/mL.

5 [0409] FIG. 19P shows determined concentration profiles of ranibizumab in the vitreous humor for a 50 uL Lucentis™ injection into a 125 uL reservoir device having a release rate index of 0.065. The concentration of ranibizumab in the vitreous at 180 days is about 3.065 ug/mL.

[0410] The optimal RRI for the concentration of ranibizumab at 180 days for a reservoir  
 10 volume of 125 uL and a 50 uL injection of Lucentis™ can be calculated based on the equations as described herein, and is about 0.085. Although the optimal value is 0.085, the above graphs show that the reservoir and release rate index can be tuned to provide therapeutic amounts of ranibizumab above a minimum inhibitory concentration of 3 ug/mL with many values of the RRI and reservoir volume, for example values within about +/-30% to +/-50% of the optimal  
 15 values for the predetermined quantity of Lucentis™ formulation.

[0411] Table 4E shows values of parameters used to determine the ranibizumab concentration profiles as in FIGS. 19K to 19P.

Table 4E.

Diffusion coeff (cm <sup>2</sup> /s)	1.0E-06
Initial Loading (ug/mL)	10000
Reservoir Vol (ml)	0.125
PA/TL (mm)	varied
Half-life (days)	9
Rate constant, k (1/day)	0.077
Vitreous vol (ml)	4.5
Volume injected (mL)	0.05
Time step (days)	0.1
Time between refills (days)	180
Refill Efficiency	100%

20 [0412] The therapeutic concentration profiles of examples of FIGS. 19B to 19P were determined with a nine day half-life of the drug in the vitreous humor of the human eye. The

therapeutic concentration profiles can be scaled in accordance with the half life of the therapeutic agent in the eye. For example, with an eighteen day half life, the concentration in these examples will be approximately twice the values shown in the graph at the extended times, and with a 4.5 day half-life, the concentrations will be approximately half the values shown with the extended times. As an example, a drug half life of eighteen days instead of nine days will correspond to a concentration of about 1.4 ug/mL at 360 days instead of about 0.6 ug/mL as shown in FIGS. 19F and 19K. This scaling of the concentration profile based on drug half life in the vitreous can be used to tune the volume and sustained release structures of the therapeutic device, for example in combination with the minimum inhibitory concentration. Although the above examples were calculated for Lucentis<sup>TM</sup>, similar calculations can be performed for therapeutic agents and formulations as described herein, for example as described herein with reference to Table 1A.

**[0413]** Based on the teachings described herein, a person of ordinary skill in the art can determine the release rate index and volume of the therapeutic agent based on the volume of formulation injected into the device and minimum inhibitory concentration. This tuning of the device volume and release rate index based on the volume of formulation injected can produce unexpected results. For example, with a clinically beneficial minimum inhibitory concentration of about 4 ug/mL, a single bolus injection corresponding to a one month injection can provide a therapeutic benefit for an unexpected three or more months, such as four months. Also, for a clinically beneficial minimum inhibitory concentration of at least about 1.5 ug/mL, a single bolus injection corresponding to a one month injection can provide a therapeutic benefit for an unexpected twelve or more months. The clinically beneficial minimum inhibitory concentration can be determined empirically based on clinical studies as described herein.

**[0414]** Although the examples of FIGS. 19F to 19K assumed a filling efficiency of one hundred percent, a person of ordinary skill in the art based on the teachings as described herein can determine the release rate profiles for filling efficiencies less than 100%, for example with 90% filling efficiency as shown above. Such filling efficiencies can be achieved with injector apparatus and needles as described herein, for example with reference to FIGS. 7, 7A, 7A1 and 7A2.

[0415] FIG. 19Q shows determined concentrations of ranibizumab in the vitreous humor for a 10 uL concentrated Lucentis™ (40 mg/mL) injection into a 10 uL device having a release rate index of 0.01 and in which the ranibizumab has a half life in the vitreous humor of about nine days. These data show that an injection of 10 uL of concentrated (40 mg/mL) Lucentis™ into a 5 10 uL reservoir device can maintain the concentration of Lucentis™ above at least about 2 ug/mL for at least about 180 days when the half life of Lucentis™ in the vitreous is at least about nine days, and that the device can provide therapeutic concentrations for an extended time of at least about 180 days when the minimum inhibitory concentration comprises no more than about 2 ug/mL.

10 [0416] FIG. 19R shows determined concentrations of ranibizumab in the vitreous humor for a 10 uL concentrated Lucentis™ (40 mg/mL) injection into a 10 uL device having a release rate index of 0.01 and in which the ranibizumab has a half life in the vitreous humor of about five days. These data show that an injection of 10 uL of concentrated (40 mg/mL) Lucentis™ into a 10 uL reservoir device can maintain the concentration of Lucentis™ above at least about 1 15 ug/mL for at least about 180 days when the half life of Lucentis™ in the vitreous is at least about five days, and that the device can provide therapeutic concentrations for an extended time of at least about 180 days when the minimum inhibitory concentration comprises no more than about 1 ug/mL.

[0417] FIG. 19S shows determined concentrations of ranibizumab in the vitreous humor for a 20 10 uL standard Lucentis™ (10 mg/mL) injection into a 10 uL device having a release rate index of 0.01 and in which the ranibizumab has a half life in the vitreous humor of about nine days. These data show that an injection of 10 uL of standard commercially available (10 mg/mL) Lucentis™ into a 10 uL reservoir device can maintain the concentration of Lucentis™ above at least about 0.5 ug/mL for at least about 180 days when the half life of Lucentis™ in 25 the vitreous is at least about nine days, and that the device can provide therapeutic concentrations for an extended time of at least about 180 days when the minimum inhibitory concentration comprises no more than about 0.5 ug/mL.

[0418] FIG. 19T shows determined concentrations of ranibizumab in the vitreous humor for a 10 uL standard Lucentis™ (10 mg/mL) injection into a 10 uL device having a release rate 30 index of 0.01 and in which the ranibizumab has a half life in the vitreous humor of about five

days. These data show that an injection of 10 uL of standard commercially available (10 mg/mL) Lucentis™ into a 10 uL reservoir device can maintain the concentration of Lucentis™ above at least about 0.25 ug/mL for at least about 180 days when the half life of Lucentis™ in the vitreous is at least about five days, and that the device can provide therapeutic  
5 concentrations for an extended time of at least about 180 days when the minimum inhibitory concentration comprises no more than about 0.25 ug/mL.

**Example 10: Calculations of target device characteristics for a device releasing drug from a suspension**

[0419] Triamcinolone acetonide is a corticosteroid used to treat uveitis and other diseases  
10 involving ocular inflammation. A 4 mg intravitreal injection of a suspension of triamcinolone acetonide may be administered to patients unresponsive to topical corticosteroids. Calculations as described herein were performed to determine the characteristics of a device that would release therapeutic amounts for an extended period of time.

[0420] Consider a device with 10 uL reservoir volume loaded with 0.4 mg using a  
15 commercial drug product (40 mg/mL triamcinolone acetonide). Calculations were performed using a value of 19 ug/mL for the solubility of triamcinolone acetonide measured at 37°C in 0.2 M potassium chloride and a diffusion coefficient of  $5 \times 10^{-6}$  cm<sup>2</sup>/s representative of a small molecule. The target release rate is 1 ug/day based upon published clinical data. As an  
20 example, consider the 0.2 media grade stainless steel characterized in Example 8 with P/F = 0.12 and a thickness of 0.5 mm. Using these values, the calculations suggest that therapeutic release rates could be achieved with a device containing a porous cylinder with an area of 5 mm<sup>2</sup>. This could be achieved with a cylindrical device having an inner diameter of 2 mm and a length of porous tubing of 1 mm. Alternatively, the end of the device could be a porous cup with height of 0.8 mm (0.5 mm thick porous face plus 0.3 mm length) of porous tubing.

25 [0421] Assuming a typical value of 3 hours for the half-life of a small molecule in the vitreous, these calculations suggest the device will achieve a steady state triamcinolone acetonide vitreous concentration of 0.12 ug/mL.

**Example 11: Calculation of release rate profile for a therapeutic agent suspension disposed in the reservoir and released through the porous frit structure**

[0422] FIG. 20 shows a calculated time release profile of a therapeutic agent suspension in a reservoir as in Example 10. Triamcinolone Acetonide concentrations in human vitreous were determined for a 10 uL device with RRI of 1.2 mm and shown. The calculations were based on the equations shown above for the suspension. The profile was generated with numerical  
5 simulation. Assuming a constant delivery rate of 1 ug/day starting instantaneously at T=0, the concentration in the vitreous of a human eye can reach within 99% of the steady state value in 1 day. At the other end of the drug release profile, the simulation shows the vitreous concentration when substantially all of the solid drug is gone; more than 99% of the dissolved drug is delivered within a day.

10 [0423] Assuming a typical value of 3 hours for the half-life of a small molecule in the vitreous, these calculations indicate that the device will achieve a substantially steady state triamcinolone acetonide vitreous concentration of 0.12 ug/mL in the rabbit or monkey (vitreous volume of 1.5 mL) or 0.04 ug/mL in the human eye (vitreous volume of 4.5 mL). The steady state vitreous concentration are maintained until there is no longer solid triamcinolone  
15 acetonide of the suspension in the reservoir. As shown in FIG. 20, a device with a 10 uL reservoir volume and Release Rate Index of 1.2 mm can produce substantially constant drug concentration amounts in the human vitreous for approx. 400 days. Additional experimental and clinical studies based on the teachings described herein can be conducted to determine the release rate profile *in situ* in human patients, and the drug reservoir volume and release rate  
20 index configured appropriately for therapeutic benefit for a target time of drug release. The substantially constant drug concentration amounts can provide substantial therapy and decrease side effects. Similar studies can be conducted with many suspensions of many therapeutic agents as described herein, for example suspensions of corticosteroids and analogues thereof as described herein.

25 **Example 12: Measured of release rate profiles for Avastin™ through the porous frit structures coupled to reservoirs of different sizes and dependence of release rate profile on reservoir size.**

[0424] FIG. 21 shows a release rate profiles of therapeutic devices comprising substantially similar porous frit structures and a 16 uL reservoir and a 33 uL reservoir. The release rate  
30 index of each frit was approximately 0.02. The release rate for two therapeutic devices each

comprising a 16 uL reservoir and two therapeutic devices each comprising a 33 uL reservoir are shown. The device comprising the 33 uL reservoir released the Avastin™ at approximately twice the rate of the device comprising 16 uL reservoir. These measured data show that the release rate index and reservoir size can determine the release rate profile, such that the release rate index and reservoir can be configured to release the therapeutic agent for an extended time.

[0425] First Study: The data were measured with a 16 uL volume reservoir as follows: 25 mg/mL Avastin™; Frit #2 (0.031 x 0.049", media grade 0.2 um, 316L SS, Mott Corporation); Substantially similar materials as Example 8 above (Teflon heat shrink tubing and silicone septum); 37C; Data is truncated when one of two replicates formed a bubble. See data in Table 5A below.

[0426] Second Study: The data were measured with a 33 uL reservoir as follows: 25 mg/mL Avastin™; Frit #2 (0.031 x 0.049", media grade 0.2 um, 316L SS, Mott Corporation); Machined from solid beading, closed with a metal rod; 37C; Data is truncated when one of two replicates formed a bubble.

Table 5A. Measured Release of Avastin™ and RRI.

Volume (uL)	Device	RRI (mm)	SS (ug/day) <sup>2</sup>
33	1	0.015	0.35
33	2	0.018	0.16
16	1	0.018	0.05
16	2	0.022	0.06
	Mean	0.018	
	%CV	16%	

[0427] SS is the average of the squared difference between predicted and measured rates, and %CV refers to the coefficient of variation, a known statistical parameter.

**Example 13: Measured release rate profiles for Avastin™ through the porous frit structures.**

[0428] FIG. 22A shows cumulative release for Avastin™ with porous frit structures having a thickness of 0.049". The experiments used: 25 mg/mL Avastin™; Frit #2 (0.031 x 0.049", media grade 0.2 um, 316L SS, Mott Corporation); Machined polycarbonate surrogate with screw; Reservoir Volume 37 uL; 37C. The device number and corresponding RRI's for each

tested device are listed in Table 5B below. The determined RRI based on measurements is 0.02, consistent with the model for release of the therapeutic agent as described herein. Although some variability is noted with regards to the measured RRI for each test device, the RRI for each device can be used to determine the release of the therapeutic agent, and the porous structure can be further characterized with gas flow as described herein to determine the RRI prior to placement in the patient.

Table. 5B

Device	RRI (mm)	SS (ug/day) <sup>2</sup>
1	0.029	26.0
2	0.027	8.5
5	0.018	3.7
30	0.013	0.1
31	0.013	0.1
32	0.015	0.7
33	0.022	30.5
Mean	0.020	
%CV	34%	

[0429] FIG. 22B1 shows cumulative release for Avastin<sup>TM</sup> with porous frit structures having a thickness of 0.029". The experiments used: 25 mg/mL Avastin<sup>TM</sup>; Frit #3 (0.038 x 0.029", media grade 0.2 um, 316L SS, Mott Corporation); Machined polycarbonate surrogate with screw; Reservoir Volume 37 uL; 37C. The device number and corresponding RRI's for each tested device are listed in Table 5C below. The determined RRI based on measurements is 0.034, consistent with the model for release of the therapeutic agent as described herein. Although some variability is noted with regards to the measured RRI for each test device, the RRI for each device can be used to determine the release of the therapeutic agent, and the porous structure can be further characterized with gas flow as described herein to determine the RRI prior to placement in the patient.

Table 5C



Device	RRI (mm)	SS (ug/day) <sup>2</sup>
9	0.033	0.7
10	0.044	10.8
13	0.030	0.7
27	0.043	15.8
28	0.033	2.6
34	0.030	0.9
35	0.027	0.3
36	0.034	5.5
Mean	0.034	
%CV	19%	

[0430] Table 5D shows an update to Table 5B showing experimental results for up to 130 days. Similarly, Table 5E is an update to Table 5C. In both cases, the RRI was determined by fitting the rate data from each device. For the analysis of data up to 130 days, the first data point is excluded from the fit because the model assumes the maximum delivery rate occurs at time zero while there is some startup time often associated with measured release profiles. The startup time may be related to the time it takes to displace all of the air in the frit. Use of different techniques to displace the air in the frit may reduce the startup time.

[0431] This early data has some noise that appears to be related to experimental issues such as contamination from excess protein that is present on the screw from filling the device and was not completely rinsed off at the start of the experiment. The contamination appears to occur randomly as receiver liquid may rinse off the protein while transferring the device from vial to vial at some timepoints but not others. A more accurate assessment of RRI can be obtained by using devices that had fewer or no outliers, as indicated by low values of SS. When this is done, the RRIs from Table 5D and 5E are 0.014 and 0.030 mm, respectively. Similar values for RRI are obtained from data up to 45 days and data up to 130 days, supporting the validity of the model.

Table 5D

Device	Up to 45 Days		Up to 130 Days	
	RRI (mm)	SS (ug/day) <sup>2</sup>	RRI (mm)	SS (ug/day) <sup>2</sup>
1	0.029	26.0	0.032	13.7
2	0.027	8.5	0.028	5.5
5	0.018	3.7	0.014	1.7
30	0.013	0.1	0.021	4.8
31	0.013	0.1	0.022	9.3
32	0.015	0.7	0.023	3.4
33	0.022	30.5	0.028	16.4
Mean	0.020		0.024	
%CV	34%		24%	
Mean for SS<2	0.014		0.014	

Table 5E

Device	Up to 45 Days		Up to 130 Days	
	RRI (mm)	SS (ug/day) <sup>2</sup>	RRI (mm)	SS (ug/day) <sup>2</sup>
9	0.033	0.7	0.034	4.4
10	0.044	10.8	0.034	2.0
13	0.030	0.7	0.044	11.6
27	0.043	15.8	0.045	6.8
28	0.033	2.6	0.031	0.5
34	0.030	0.9	0.030	0.7
35	0.027	0.3	0.029	1.3
36	0.034	5.5	0.034	5.9
Mean	0.034		0.035	
%CV	19%		17%	
Mean for SS<2	0.030		0.030	

5 [0432] FIG. 22B2 shows rate of release for Avastin<sup>TM</sup> with porous frit structures having a thickness of 0.029” as in FIG. 22B1. The rate of release can be determined from the measurements and the cumulative release. The outliers in this data can be related to measurement error, such as contamination that provides a signal in the mBCA protein assay.

10 [0433] FIG. 23A shows cumulative release for Avastin<sup>TM</sup> with a reservoir volume of 20 uL. The experiment used: 25 mg/mL Avastin<sup>TM</sup>; Frit #6 (0.038 x 0.029”, media grade 0.2 um, 316L SS, Mott Corporation); Machined polycarbonate surrogate with screw; 37C. The determined

RRI based on measurements is 0.05 mm, consistent with the model for release of the therapeutic agent as described herein.

[0434] FIG. 23A-1 shows cumulative release to about 90 days for Avastin<sup>TM</sup> with a reservoir volume of 20 uL as in FIG. 23A. The RRI of 0.053 mm corresponds substantially to the RRI of 0.05 of FIG. 23 and demonstrates stability of the release of therapeutic agent through the porous structure.

[0435] FIG. 23B shows rate of release as in FIG. 23A. The release rate data show a rate of release from about 5 ug per day to about 8 ug per day. Although the initial release rate at the first day is slightly lower than subsequent rates, the rate of release is sufficiently high to provide therapeutic effect in accordance with the drug release model. Although there can be an initial period of about a few days for the release rate profile to develop, possibly related to wetting of the interconnecting channels of the porous structure, the release rate profile corresponds substantially to the release rate index (RRI) of 0.05. Based on the teachings described herein, a person of ordinary skill in the art could determine the release rate profile with additional data for an extended time of at least about one month, for example at least about three months, six months or more, so as to determine the release rate profile for an extended time.

[0436] FIG. 23B-1 shows rate of release as in FIG. 23A-1.

[0437] FIG. 24A shows cumulative release for Avastin<sup>TM</sup> with a 0.1 media grade porous frit structure. This experiment used: 25 mg/mL Avastin<sup>TM</sup>; Frit #5 (0.038 x 0.029", media grade 0.1 um, 316L SS, Mott Corporation); Machined polycarbonate surrogate with screw; Reservoir Volume 20 uL; 37C. The determined RRI based on measurements is 0.03, consistent with the model for release of the therapeutic agent as described herein.

[0438] FIG. 24A-1 shows cumulative to about 90 days release for Avastin<sup>TM</sup> with a 0.1 media grade porous frit structure as in FIG. 24A. The release rate of 0.038 mm corresponds substantially to the release rate of 0.03 of FIG. 24A and demonstrates the stability of release of the therapeutic agent through the porous structure.

[0439] FIG. 24B shows rate of release as in FIG. 24A. The release rate data show a rate of release from about 2 ug per day to about 6 ug per day. Although the initial release rate at the

first day is slightly lower than subsequent rates, the rate of release is sufficiently high to provide therapeutic effect in accordance with the drug release model. Although there can be an initial period of a few days for the release rate profile to develop, possibly related to wetting of the interconnecting channels of the porous structure, the release rate profile corresponds

5 substantially to the release rate index (RRI) of 0.03. Based on the teachings described herein, a person of ordinary skill in the art could determine the release rate profile with additional data for an extended time of at least about one month, for example at least about three months, six months or more, so as to determine the release rate profile for an extended time.

[0440] FIG. 24B-1 shows rate of release as in FIG. 24A-1.

10 **Example 14: Determination of Therapeutic Device Size and Lifetime based on Minimum Inhibitory Concentration *In Vivo* of Therapeutic Agent**

[0441] Numerical calculations were performed to determine therapeutic device sizes, release rate profiles and expected therapeutic agent concentration in the reservoir. The concentration in the reservoir may correspond to the useful lifetime of the device, or time between injections

15 of therapeutic agent into the reservoir or other replacement of the therapeutic agent.

[0442] Table 6A shows the number days of therapeutic agent is released from the device with concentration amounts at or above the MIC. These number of days correspond to an effective lifetime of the device or effective time between injections into the device. The calculations show the number of days of the extended time release based the RRI and MIC for a 20 uL

20 reservoir volume having a drug concentration disposed therein of 10 mg/ml. The RRI ranged from 0.01 to 0.1 and the MIC ranged from 0.1 to 10, and can be determined with experimental and clinical studies as described herein. The half-life of therapeutic agent in the vitreous was modeled as 9 days, based on human data. The C<sub>max</sub> indicates the maximum concentration of therapeutic agent in the vitreous humor, for example within a few days of placement or

25 injection of the therapeutic agent in the device. These data indicate that the device can maintain the concentration of therapeutic agent for about 756 days, 385 days, 224 days, and 62 day for MIC's of 0.1, 0.5, 1, 2 and 4 ug/ml, respectively. For example, the therapeutic agent may comprise Lucentis™ having an MIC of about 0.5 and the device may maintain therapeutic concentrations of the agent for one year. These numerical data also show a concentration of

30 therapeutic agent released from the device within a range of the current clinical bolus

injections. For example, the C<sub>max</sub> ranges from 2.1 to 11.9 based on the RRI from 0.01 to 0.1 respectively, such that the maximum release of therapeutic agent such as Lucentis™ is within a safe range for the patient.

[0443] A person of ordinary skill in the art can conduct experiments to determine the stability of the therapeutic agent such as Lucentis™ in the reservoir, and adjust the size of the reservoir, time between injections or removal. The therapeutic agent can be selected and formulated so as to comprise a stability suitable for use in the therapeutic device.

Table 6A. Calculations for Time (days) above MIC (20µL Reservoir Volume, T<sub>1/2</sub> = 9 days, Drug Conc. in Reservoir = 10 mg/ml )

RRI	C <sub>max</sub> (µg/ml)	MIC (µg/ml)						
		0.1	0.5	1	2	4	7	10
0.01	2.1	756	385	224	62	0	0	0
0.02	3.8	467	280	200	119	0	0	0
0.04	6.5	281	188	148	108	66	0	0
0.06	8.6	209	147	120	93	65	40	0
0.08	10.4	170	124	103	83	61	42	14
0.1	11.9	146	109	92	75	58	42	30

10

[0444] Table 6B. Shows calculations for time (days) above the MIC for a therapeutic device comprising a 20µL Volume, Vitreous T<sub>1/2</sub> = 9 days, and Drug Conc. in Reservoir = 40 mg/ml. The embodiments of Table 6B include similar components to the embodiments of Table 6A and the improved time above MIC achieved with concentration of 40 mg/ml. For example, the time above the MIC can be 1079, 706, 546, 385, 225, 95, for MIC's of 0.1 0.5, 1, 2, 4, and 7 µg/ml, respectively. For example, the therapeutic agent may comprise Lucentis™ having an MIC of about 0.5 and the device may maintain therapeutic concentrations of the therapeutic agent for about 2 years. These numerical data also show a concentration of therapeutic agent released from the device within a range of the current clinical bolus injections. For example,

20

the Cmax ranges from 8.4 to 47.6 based on the RRI from 0.01 to 0.1 respectively, such that the maximum release of therapeutic agent such as Lucentis™ is within a safe range for the patient.

[0445] A person of ordinary skill in the art can conduct experiments to determine the stability of the therapeutic agent such as Lucentis™ in the reservoir, and adjust the size of the reservoir, time between injections or removal. The therapeutic agent can be selected and formulated so as to comprise a stability suitable for use in the therapeutic device.

Table 6B. Calculations for Time (days) above MIC (20µL Volume, T1/2 = 9 days, Drug Conc. in Reservoir = 40 mg/ml)

RRI	Cmax (µg/ml)	MIC (µg/ml)						
		0.1	0.5	1	2	4	7	10
0.01	8.4	1079	706	546	385	225	95	0
0.02	15.1	626	440	360	280	200	135	93
0.04	25.9	361	268	228	188	148	115	94
0.06	34.4	262	200	174	147	120	98	84
0.08	41.5	210	164	144	124	103	87	76
0.1	47.6	179	141	125	109	92	79	70

10

[0446] Table 6C. Shows calculations for time (days) above the MIC for a therapeutic device comprising a 50µL Volume, Vitreous T1/2 = 9 days, and Drug Conc. in Reservoir = 40 mg/ml. The embodiments of Table 6B include similar components to the embodiments of Table 6A and the improved time above MIC achieved with concentration of 40 mg/ml. For example, the time above the MIC can be 2706, 1737, 1347, 944, 542 and 218, for MIC's of 0.1 0.5, 1, 2, 4, and 7 ug/ml, respectively. For example, the therapeutic agent may comprise Lucentis™ having an MIC of about 0.5 and the device may maintain therapeutic concentrations of the therapeutic agent for more than about 2 years. These numerical data also show a concentration of therapeutic agent released from the device within a range of the current clinical bolus injections. For example, the Cmax ranges from 9.1 to 64.7 ug/ml based on the RRI from 0.01

20

to 0.1 respectively, such that the maximum release of therapeutic agent such as Lucentis™ is within a safe range for the patient.

- [0447] A person of ordinary skill in the art can conduct experiments to determine the stability of the therapeutic agent such as Lucentis™ in the reservoir, and adjust the size of the reservoir, time between injections or removal. The therapeutic agent can be selected and formulated so as to comprise a stability suitable for use in the therapeutic device.

Table 6C. Calculations for Time (days) above MIC (50µL Volume, T1/2 = 9 days, Drug Conc. in Reservoir = 40 mg/ml)

RRI	C <sub>max</sub> (µg/ml)	MIC (µg/ml)						
		0.1	0.5	1	2	4	7	10
0.01	9.1	2706	1737	1347	944	542	218	0
0.02	17.2	1560	1082	880	679	478	316	213
0.04	31.5	887	648	547	446	346	265	213
0.06	43.8	635	476	408	341	274	220	186
0.08	54.8	501	381	331	281	230	190	164
0.1	64.7	417	321	281	240	200	168	147

- 10 [0448] The examples shown in Tables 6A to 6C can be modified by one of ordinary skill in the art in many ways based on the teachings described herein. For example, the 50 uL reservoir may comprise an expanded configuration of the reservoir after injection of the therapeutic device. The reservoir and/or quantity of therapeutic agent can be adjusted so as to provide release for a desired extended time.
- 15 [0449] The porous frit structure as described herein can be used with many therapeutic agents, and may limit release of therapeutic agent that has degraded so as to form a particulate, for example. Work in relation to embodiments suggests that at least some therapeutic agents can degrade so as to form a particulate and that the particulate comprising degraded therapeutic agent may have an undesired effect on the patient, and the porous frit structure as described

herein may at least partially filter such particulate so as to inhibit potential side effects of degraded therapeutic agent.

[0450] Table 6D shows examples of sizes of therapeutic devices that can be constructed in accordance with the teachings described herein, so as to provide a suitable volume of the drug reservoir within the container and such devices may comprise many lengths, widths and structures as described herein. For example the frit outside diameter (hereinafter “OD”) can be configured in many ways and may comprise about 1mm, for example, or about 0.5 mm. The length of the frit (thickness) may comprise about 1 mm. The volume of the frit can be, for example, about 0.785 uL, or about 0.196 uL, for example. The volume of the reservoir can be from about 0.4 uL to about 160 uL, for example. The volume of the therapeutic device can be from about 0.6 uL to about 157 uL, and can be positioned in many ways, for example with a lumen and may comprise a substantially fixed volume reservoir or an expandable reservoir. The cross sectional width of the device may correspond to many sizes, for example many radii, and the radius can be within a range from about 0.3 mm to about 3.5 mm, for example. The cross-section width and corresponding diameters of the device can be within a range from about 0.6 mm to about 7 mm. The length of the device, including the porous structure, container and retention structure can be many sizes and can be within a range from about 2 mm to about 4 mm, for example. The device may comprise a substantially fixed diameter, or alternatively can be expandable, and may comprise fixed or expandable retention structures, as described herein.

Table 6D.

Frit OD (mm)	1	0.5										
Frit Length (mm)	1	1										
Frit Vol. (uL)	0.785	0.19625										
Vol Res (uL)	0.4	2	4	8	16	27	31	39	63	110	157	
Vol Frit (uL)	0.19625	0.19625	0.785	0.785	0.785	0.785	0.785	0.785	0.785	0.785	0.785	0.785
Vol Device (uL)	0.59625	2.19625	4.785	8.785	16.785	27.785	31.785	39.785	63.785	110.785	157.785	



Radius squared	0.09	0.3	0.4	0.7	1.3	2.2	2.5	3.2	5.1	8.8	12.6
Radius (mm)	0.3	0.5	0.6	0.8	1.2	1.5	1.6	1.8	2.3	3.0	3.5
OD (mm)	0.6(4)	1.1(3)	1.2(3)	1.7(3)	2.3(3)	3.0(2)	3.2(2)	3.6(2)	4.5(2)	5.9(2)	7.1(2)
Dev Length (mm)	2.0(6)	2.5(5)	4.0(1)	4.0(1)	4.0(1)	4.0(1)	4.0(1)	4.0(1)	4.0(1)	4.0(1)	4.0(1)
		(1) Fixed penetration upper limit									
		(2) May use non simple cylinder design to decrease incision length, for example expandable reservoir									
		(3)OD accommodates 1mm diameter porous frit structure and satisfies incision length limit									
		(4) Device OD may use a smaller porous frit structure									
		(5) Length reduced to drive OD to accommodate porous frit structure									
		(6)Length reduced to drive OD to accommodate porous frit structure, and Device OD may use smaller frit									

**Example 15A: Calculation and measurement of small release rate profiles as a model for a therapeutic agent released through the porous frit structure**

5 [0451] Studies of the release of fluorescein from reservoirs through porous frit structures were conducted so as to determine the release of small molecule drugs through the porous frit structure. The fluorescein model shows that the porous frit structures and reservoirs as described herein are suitable for use with small molecule drug deliver. The release profiles of Avastin™, Lucentis™ and BSA in conjunction with the fluorescein data show that the porous  
 10 frit structures and reservoirs can be used for sustained release of many drugs, molecules and therapeutic agents of many molecular weights and sizes.

[0452] FIG. 25A shows cumulative release for fluorescein through a 0.2 media grade porous frit structure. The experiment used: 2 mg/mL Fluorescein sodium; Frit #2 (0.031 x 0.049”, media grade 0.2 um, 316L SS, Mott Corporation); Machined polycarbonate surrogate with  
 15 screw; 37C. The fluorescein samples were assayed by UV absorbance at 492 nm with a plate reader. The determined RRI based on measurements is 0.02, consistent with the model for release of the therapeutic agents as described herein.

[0453] FIG. 25A-1 shows cumulative release to about 90 days for fluorescein through a 0.2 media grade porous frit structure as in FIG. 25A. The mean RRI based upon the first four data

points was 0.02 mm. The mean RRI to release for 90 days (excluding the first point) is 0.026 mm. These data show stability of the rate of release and that the porous frit structure can be used for small molecule delivery or large molecule delivery, or combinations thereof.

[0454] FIG. 25B shows rate of release as in FIG. 25A. The release rate data show a rate of release from about 1.0 ug per day to about 1.8 ug per day. Although the initial release rate at the first day is slightly lower than subsequent rates, the rate of release is sufficiently high to provide therapeutic effect in accordance with the drug release model. Although there can be an initial period of about a day for the release rate profile to develop, possibly related to wetting of the interconnecting channels of the porous structure, the release rate profile corresponds substantially to the release rate index (RRI) of 0.02. Based on the teachings described herein, a person of ordinary skill in the art could determine the release rate profile with additional data for an extended time of at least about one month, for example at least about three months, six months or more, so as to determine the release rate profile for an extended time.

[0455] FIG. 25B-1 shows rate of release as in FIG. 25A-1.

**Example 15B: Measured release rate profiles for Lucentis™ through the porous frit structures.**

[0456] The experiments used: 10 mg/mL Lucentis™; Machined poly(methyl methacrylate) surrogate with screw; and a Reservoir Volume 30 uL; 37C. All porous frit structures are 316L SS, Mott Corporation. Data shown are measured data from all devices except for a few samples that showed either bubble growth or low receiver volume.

[0457] Table 6E shows results for 39 out of 48 devices were included in the table and graphs shown below. The data from the *in vitro* studies shown in Table 6E show that Lucentis™ can be delivered with the device having porous frit structure. The diameter ranged from 0.031" to 0.038", and the length ranged from 0.029 to 0.049. The media grade ranged from 0.1 to 0.3, and the RRI ranged from 0.014 to 0.090. The data show very low variability suitable in *in vivo* human treatment, with the %CV below 10% in all instances, and less than 3% for four of five device configurations measured.

[0458] Although some of the measurements were excluded, this exclusion is appropriate and associated with *in vitro* testing conditions that differ substantially from the *in vivo* model. Five

devices were excluded due to bubble growth (10%), and four were excluded due to receiver volume issues at one timepoint for that device (8%). The latter can be an experimental error associated with the volume of the receiver below the assumed value due to evaporation from inadequately sealed vials or due to pipetting error. In some instances the *in vitro* experimental test apparatus can be sensitive to bubble formation that may differ substantially from the *in vivo* model as the living eye can resorb oxygen from the therapeutic devices. Bubbles can form as receiver fluid is heated to 37°C and gas concentrations are greater than their solubilities at 37°C. To minimize the occurrence of bubble formation, receiver solutions were degassed before insertion of the devices. These experimental *in vitro* studies suggest that degassing of samples can be helpful with the *in vitro* assays.

[0459] Table 6E.

Frit Dimensions		Media Grade (µm)	RRI (mm)	%CV	Number of Replicates
Dia	Length				
0.038"	0.029"	0.3	0.090	2.1%	6
0.038"	0.029"	0.2	0.061	2.8%	14
0.038"	0.029"	0.1	0.039	2.3%	5
0.031"	0.049"	0.2	0.021	9.9%	12
0.031"	0.049"	0.1	0.014	2.5%	2

[0460] FIG. 25C shows cumulative release to about thirty days for Lucentis™ through a 0.2 media grade porous frit structure having a diameter of 0.038 in and a length (thickness) of 0.029, corresponding to a release rate of 0.061 as shown in the second row of Table 6E.

[0461] FIG. 25D shows rates of release of the devices as in FIG. 25C.

[0462] FIG. 25E shows cumulative release to about thirty days for Lucentis™ for 30 µL devices having a RRI's from about 0.090 to about 0.015.

[0463] FIG. 25F shows rates of release of the devices as in FIG. 25E.

[0464] These above experimentally measured data show stable release of the Lucentis™ for 30 days for a wide range of frit diameters, thicknesses and media grades consistent with the release rate model of the porous structure and reservoir as described herein. For example, the media grade, thickness, diameter and reservoir volume can be tuned to provide sustained  
5 release for a predetermined period of time above a predetermined targeted minimum inhibitory concentration. When combined with the Avastin™ and Fluorescein data, these data show that stable release can be achieved for extended times for many therapeutic agents consistent with the release model as described herein.

#### **Example 16: Scanning Electron Micrographs of Porous Frit Structures**

10 [0465] FIGS. 26A and 26B show scanning electron microscope images from fractured edges of porous frit structures of 0.2 media grade and 0.5 media grade porous material, respectively. The commercially available samples were obtained from Mott Corporation and comprised 316L stainless steel. The samples were mechanically fractured so as to show the porous structure and interconnecting channels within the material to release the therapeutic agent. The  
15 micrograph images show a plurality of interconnecting channels disposed between openings of the first surface and openings of the second surface.

[0466] FIGS. 27A and 27B show scanning electron microscope images from surfaces of porous frit structures of media grade of 0.2 and 0.5, respectively, from the samples of Figs 26A and 26B. The images show a plurality of openings on the surface connected with  
20 interconnecting channels as in FIGS. 26A and 26B.

#### **Example 17: Porous Frit Structure Mechanical Flow Testing to Identify Porous Frit Structures Suitable for Use with Therapeutic Agent Delivery Devices**

[0467] The relative characteristics of sample elements can be determined by subjecting the frit to a number of mechanical tests, including but not limited to pressure decay and flow.  
25 These tests can be combined with drug release rate information, for example the RRI, so as to determine the release profile of the devices. These tests can be used with the porous structure positioned on the therapeutic device, so as to quantify flow through the porous structure of the device and determine suitability of the porous structure. Similar tests can be used to quantify the porous structure prior to mounting on the therapeutic device. At least some of the therapeutic

devices can be evaluated with the gas flow of the porous structure mounted on a partially assembled therapeutic device, for example as a quality control check. In some embodiments, the flow test can be performed on the partially assembled or substantially assembled therapeutic device prior to insertion of the therapeutic agent into the reservoir and prior to  
5 insertion into the patient, so as to ensure that the porous structure is suitable for release of the therapeutic agent and affixed to the device, for example a support of the therapeutic device.

[0468] These tests may utilize a variety of working fluids, but will most likely use a readily available gas such as air or nitrogen. To date, flow and pressure decay tests have been used to identify different frit characteristics that may be correlated to other test results such as chemical  
10 or pharmacologic performance.

#### **Fixturing**

[0469] Each of the test methods above may use a mechanical connection of the test specimen to the test hardware and a number of techniques have been explored and employed. These fixtures include a both a means of reliably securing the specimen (such as heat recoverable  
15 tubing, elastic tubing, press fits into relatively rigid components, etc.) and a means of coupling (such as a luer, barbed fitting, quick connect coupling, etc.) that allow convenient and repeatable attachment to the test hardware.

#### **Test Hardware**

[0470] Each of the desired tests can be developed using commercially available solutions, or  
20 by assembling readily available instrumentation to create a custom test arrangement. Again, both of these approaches have been evaluated. A working system will consist of a means for connecting a test specimen, a controllable source (usually, but not limited to pressure), a manometer (or other pressure measurement device), and one or more transducers (pressure, flow, etc.) used to measure the test conditions and/or gather data for further analysis.

25 **Example 17A. Pressure Decay Test to Identify Porous Structures Suitable for Use with Therapeutic Drug Delivery Devices.**

[0471] FIG. 28 shows a pressure decay test and test apparatus for use with a porous structure so as to identify porous frit structures suitable for use with therapeutic devices in accordance with embodiments described herein.

[0472] One method of pressure decay testing is performed with the hardware shown  
5 schematically in FIG. 28. An initial pressure is applied to the system by an outside source such as a syringe, compressed air, compressed nitrogen, etc. The manometer may be configured to display simply the source gage pressure, or the actual differential pressure across the specimen. One side of the fixtured specimen is normally open to atmosphere, creating a pressure which will decay at a rate determined by the properties of the frit being tested. The instantaneous  
10 pressure may be measured by a pressure transducer that converts and supplies a signal to a data acquisition module (DAQ) that transfers data to a computer. The rate of pressure drop is then recorded and can be used for comparison to the performance of other frits or an acceptability requirement/specification. This comparison may be made by grossly comparing the pressure at a given time, or by directly comparing the output pressure decay curves.

[0473] An example test procedure would pressurize the system to slightly greater than 400  
15 mmHg as displayed by the manometer. The computer and DAQ are configured to begin data acquisition as the pressure drops below 400 mmHg, and a data point is taken approximately every .109 seconds. While the test can be stopped at any time, it is likely that standard discreet points along the course of pressure decay data would be selected so as to allow direct  
20 comparison of frit flow performance (e.g. time for decay from 400 mmHg to 300 mmHg, and from 400 mmHg to 200 mmHg.)

**Example 17B. Pressure Decay Test to Identify Porous Structures Suitable for Use with Therapeutic Drug Delivery Devices.**

[0474] FIG. 29 shows a pressure flow test and test apparatus suitable for use with a porous  
25 structure so as to identify porous frit structures suitable for use with therapeutic devices in accordance with embodiments described herein.

[0475] Using a similar hardware set-up, flow thru the test specimen can also be characterized. In this test, the source pressure is constantly regulated to a known pressure and the flow of a working fluid is allowed to flow thru a mass flow meter and then thru the fixtured test frit. As

in the pressure decay test, the specific characteristics of the frit determine that rate at which the working fluid will flow through the system. For additional accuracy, pressure at the otherwise open end of the fixture test frit may be regulated to control the backpressure, and therefore the pressure drop across the specimen.

5 [0476] Flow testing may have advantages over pressure decay testing due to the instantaneous nature of the method. Rather than waiting for the pressure to drop, the flow thru a sample should stabilize quickly enabling testing of large number of samples to be performed in rapid fashion.

10 [0477] In an example test procedure, a regulated compressed cylinder would supply the system with a constant source pressure of 30 psig and a constant back pressure of 1 psig. The test fluid would flow through the test frit at a characteristic rate (which is dependent on the pressure, but is expected to be in the 10-500 sccm range) as measured by the mass flow meter.

**Example 17C: Determination of Therapeutic Release Rate Based on Gas Flow**

15 [0478] Table 7 shows a table that can be used to determine release of therapeutic agent, for example the RRI, based on the flow of a gas such as oxygen or nitrogen through the porous structure. The flow through the porous structure can be measured with a decay time of the gas pressure, for with the flow rate across the porous structure with a pressure drop across the porous frit structure, as described herein. The flow rate and RRI can be determined based on the media grade of the material, for example as commercially available media grade material  
 20 available from Mott Corp. The therapeutic agent can be measured through the porous structure, or a similar test molecule. The initial measurements measured the RRI for Avastin™ with the porous frit structures shown. Based on the teachings described herein, a person of ordinary skill in the art can conduct experiments to determine empirically the correspondence of flow rate with a gas to the release rate of the therapeutic agent.

25

Table 7.

Media Grade	O.D.(in.)	Length (in.)	RRI	Flow	300 Decay	200 Decay
0.2	0.031	0.049	0.019		106	256
0.2	0.038	0.029	0.034			
0.1	0.038	0.029	0.014		81	201
0.2	0.038	0.029	0.033		31	78

[0479] The above partially populated table shows the amount and nature of frit data that can be collected. It is contemplated to use some form of non-destructive testing (i.e. not drug release testing) so as to enable:

- 5 a) QC receiving inspection testing of frits
- b) QC final device assembly testing

[0480] One of ordinary skill can demonstrate a correlation between one or more “flow” tests and the actual drug release testing which relies on diffusion rather than forced gas flow. The data suggests that flow testing of frits can be both repeatable and falls in line with expectations.

- 10 [0481] Preliminary testing also indicates that the test for the frit alone can be substantially similar to the frit as an assembled device.

[0482] Any structure or combination of structures or method steps or components or combinations thereof as described herein can be combined in accordance with embodiments as described herein, based on the knowledge of one of ordinary skill in the art and teachings described herein. In addition, any structure or combination of structures or method steps or components or combinations thereof as described herein may be specifically excluded from any  
15 embodiments, based on the knowledge of one of ordinary skill in the art and the teachings described herein.

[0483] While the exemplary embodiments have been described in some detail, by way of  
20 example and for clarity of understanding, those of skill in the art will recognize that a variety of modifications, adaptations, and changes may be employed. Hence, the scope of the present invention should be limited solely by the appended claims.



Table 1A. Therapeutic Agent List

Generic Name	Brands (Companies)	Category	Indication	Molecular Weight
2-Methoxyestradiol analogs	(Paloma Pharmaceuticals)	Angiogenesis inhibitors	AMD	
3-aminothalidomide				
13-cis retinoic acid	Accutane™ (Roche Pharmaceuticals)			
A0003	(Aqumen BioPharmaceuticals)	A0003	AMD	
A5b1 integrin inhibitor	(Jerini Ophthalmic); (Ophthotech)	Inhibitors of a5b1 integrin	AMD	
Abarelix	Plenaxis™ (Praecis Pharmaceuticals)	Anti-Testosterone Agents; Antineoplastic Agents	For palliative treatment of advanced prostate cancer.	37731
Abatacept	Orencia™ (Bristol-Myers Squibb)	Antirheumatic Agents	For the second line reduction of the signs and symptoms of moderate-to-severe active rheumatoid arthritis, inducing major clinical response, slowing the progression of structural damage, and improving physical function in adult patients who have	37697
Abciximab	ReoPro™; ReoPro™ (Centocor)	Anticoagulants; Antiplatelet Agents	For treatment of myocardial infarction, adjunct to percutaneous 134oronary intervention, unstable angina	42632
ABT-578	(Abbott Laboratories)	Limus Immunophilin Binding Compounds		

Table 1A. Therapeutic Agent List

Generic Name	Brands (Companies)	Category	Indication	Molecular Weight
Acetonide				
Adalimumab	Humira™ (Abbott Laboratories)	Antirheumatic Agents; Immunomodulatory Agents	Uveitis, AMD	25645
Aldesleukin	Proleukin™; Proleukin™ (Chiron Corp)	Antineoplastic Agents	For treatment of adults with metastatic renal cell carcinoma	61118
Alefacept	Amevive™	Immunomodulatory Agents; Immunosuppressive Agents	For treatment of moderate to severe chronic plaque psoriasis	42632
Alemtuzumab	Campath™; Campath™ (ILEX Pharmaceuticals LP); MabCampath™	Antineoplastic Agents	For treatment of B-cell chronic lymphocytic leukemia	6614
Alpha-1-proteinase inhibitor	Aralast™ (Baxter); Prolastin™ (Talecris Biotherapeutics C formerly Bayer)	Enzyme Replacement Agents	For treatment of panacinar emphysema	28518
Alteplase	Activase™ (Genentech Inc)	Thrombolytic Agents	For management of acute myocardial infarction, acute ischemic stroke and for lysis of acute pulmonary emboli	54732
AMG-1470				
Anakinra	Kineret™ (Amgen Inc)	Anti-inflammatory Agents, Non-Steroidal; Antirheumatic Agents; Immunomodulatory Agents	For the treatment of adult rheumatoid arthritis.	65403

Table 1A. Therapeutic Agent List

Generic Name	Brands (Companies)	Category	Indication	Molecular Weight
Anecortave acetate				
Angiotstatin				
Anistreplase	Eminase™ (Wulfling Pharma GmbH)	Thrombolytic Agents	For lysis of acute pulmonary emboli, intracoronary emboli and management of myocardial infarction	54732
Anti-angiogenesis peptides	(Eyecopharm)	Anti-angiogenesis peptides	AMD	
Anti-angiogenesis antibodies, TRC093, TRC105	(TRACON Pharma)	Anti-angiogenesis antibodies	AMD	
Anti-angiogenic bifunctional protein	Icon-1™ (Iconic Therapeutics)	Anti-angiogenic bifunctional protein, Icon-1	AMD	
Anti-endothelial growth factor				
Antihemophilic Factor	Advate™, Alphanate™, Bioclote™, Helixate™, Helixate FS™, Hemofil M™, Humate-P™, Hyate-C™, Koate-HP™, Kogenate™, Kogenate FS™, Monarc-M™, Monoclate-P™, Refacto™, Xyntha™	Coagulants, Thrombotic Agents	For the treatment of hemophilia A, von Willebrand disease and Factor XIII deficiency	70037
Antithymocyte globulin	Genzyme); Thymoglobulin™ (SangStat Medical	Immunomodulatory Agents	For prevention of renal transplant rejection	37173

Table 1A. Therapeutic Agent List

Generic Name	Brands (Companies)	Category	Indication	Molecular Weight
Anti-hypertensive MC1101	(MacuCLEAR)	Anti-hypertensive MC1101	AMD	
Anti-platelet devired growth factor				
Anti-VEGF	(Neurotech); Avastin™ (NeoVista)	Anti-VEGF	AMD	
AP23841	(Ariad)	Limus Immunophilin Binding Compounds		
Aprotinin	Trasylol™	Antifibrinolytic Agents	For prophylactic use to reduce perioperative blood loss and the need for blood transfusion in patients undergoing cardiopulmonary bypass in the course of coronary artery bypass graft surgery who are at an increased risk for blood loss and blood transfusio	90569
Arcitumomab	CEA-Scan™	Diagnostic Agents; Imaging Agents	For imaging colorectal tumors	57561
Asparaginase	Elspar™ (Merck & Co. Inc)	Antineoplastic Agents	For treatment of acute lymphocytic leukemia and non-Hodgkins lymphoma	132.118
Axitinib		Tyrosine Kinase Inhibitors		386
Basiliximab	Simulect™ (Novartis Pharmaceuticals)	Immunomodulatory Agents; Immunosuppressive Agents	For prophylactic treatment of kidney transplant rejection	61118

Table 1A. Therapeutic Agent List

Generic Name	Brands (Companies)	Category	Indication	Molecular Weight
Becaplermin	Regranex™; Regranex™ (OMJ Pharmaceuticals)	Anti-Ulcer Agents; Topical	For topical treatment of skin ulcers (from diabetes)	123969
Bevacizumab	Avastin™; Avastin™ (Genentech Inc)	Antiangiogenesis Agents; Antineoplastic Agents	For treatment of metastatic colorectal cancer	27043
Bivalirudin	Angiomax™; Angiomax™ (Medicines Co or MDCO); Angiox™	Anticoagulants; Antithrombotic Agents	For treatment of heparin-induced thrombocytopenia	70037
Bortezomib		Proteasome Inhibitors		
Bosutinib		Tyrosine Kinase Inhibitors		530
Botulinum Toxin Type A	BOTOX™ (Allergan Inc); BOTOX Cosmetic™ (Allergan Inc); Botox™, Dysport™	Anti-Wrinkle Agents; Antidystonic Agents; Neuromuscular Blocking Agents	For the treatment of cervical dystonia in adults to decrease the severity of abnormal head position and neck pain associated with cervical dystonia. Also for the treatment of severe primary axillary hyperhidrosis that is inadequately managed with topical	23315
Botulinum Toxin Type B	Myobloc™ (Solstice Neurosciences); Neurobloc™ (Solstice Neurosciences)	Antidystonic Agents	For the treatment of patients with cervical dystonia to reduce the severity of abnormal head position and neck pain associated with cervical dystonia.	12902
C5 inhibitor	(Jerni Ophthalmic) ; (Ophthotech)	Inhibitors of C5	AMD	
Canstatin				

Table 1A. Therapeutic Agent List

Generic Name	Brands (Companies)	Category	Indication	Molecular Weight
Capromab	ProstaScint™ (Cytogen Corp)	Imaging Agents	For diagnosis of prostate cancer and detection of intra-pelvic metastases	84331
Captopril		ACE Inhibitors		
CCI-779	(Wyeth)	Limus Immunophilin Binding Compounds		
Cediranib		Tyrosine Kinase Inhibitors		450
Celecoxib		Cyclooxygenase Inhibitors		
Cetrorelix	Cetrotide™	Hormone Antagonists; Infertility Agents	For the inhibition of premature LH surges in women undergoing controlled ovarian stimulation	78617
Cetuximab	Erbix™; Erbitux™ (ImClone Systems Inc)	Antineoplastic Agents	For treatment of metastatic colorectal cancer.	42632
Choriogonadotropin alfa	Novarel™; Ovidrel™; Pregnyl™; Profasi™	Fertility Agents; Gonadotropins	For the treatment of female infertility	78617
Ciliary neurotrophic factor	(Neurotech)	Ciliary neurotrophic factor	AMD	
Coagulation Factor IX	Benefix™ (Genetics Institute)	Coagulants; Thrombotic Agents	For treatment of hemophilia (Christmas disease).	267012

Table 1A. Therapeutic Agent List

Generic Name	Brands (Companies)	Category	Indication	Molecular Weight
Coagulation factor VIIa	NovoSeven™ (Novo Nordisk)	Coagulants; Thrombotic Agents	For treatment of hemorrhagic complications in hemophilia A and B	54732
Colchicines				
Collagenase	Cordase™; Santyl™ (Advance Biofactures Corp); Xiaflex™	Anti-Ulcer Agents; Topical	For treatment of chronic dermal ulcers and severe skin burns	138885
Complement factor H recombinant	(Optherion); (Taligen Therapeutics)	Complement factor H recombinant	AMD, Geographic Atrophy	
Compstatin derivative peptide, POT-4	(Potentia Pharmaceuticals)	Complement Factor C3 Inhibitors; Compstatin Derivative Peptides	AMD	
Corticotropin	ACTH™; Acethropan™; Acortan™; Acthar™; Exacthin™; H.P. Acthar Gel™; Isacid™; Purified cortrophin gel™; Reactin™; Solacthyl™; Tubex Cortrosyn™; Synacthen depot™	Diagnostic Agents	For use as a diagnostic agent in the screening of patients presumed to have adrenocortical insufficiency.	33927
Cosyntropin		Diagnostic Agents	For use as a diagnostic agent in the screening of patients presumed to have adrenocortical insufficiency.	33927
Cyclophilins		Limus Immunophilin Binding Compounds		
Cyclosporine	Gengraf™ (Abbott labs); Neoral™ (Novartis); Restasis™; Restasis™ (Allergan Inc); Sandimmune™ (Novartis); Sangcya™	Antifungal Agents; Antirheumatic Agents; Dermatologic Agents; Enzyme Inhibitors; Immunomodulatory Agents; Immunosuppressive	For treatment of transplant rejection, rheumatoid arthritis, severe psoriasis	32953

Table 1A. Therapeutic Agent List

Generic Name	Brands (Companies)	Category	Indication	Molecular Weight
		Agents		
Daclizumab	Zenapax™ (Hoffmann-La Roche Inc)	Immunomodulatory Agents; Immunosuppressive Agents	For prevention of renal transplant rejection	61118
Darbepoetin alfa	Aranesp™ (Amgen Inc.)	Antianemic Agents	For the treatment of anemia (from renal transplants or certain HIV treatment)	55066
Dasatinib		Tyrosine Kinase Inhibitors		488
Defibrotide	Dasovas™; Noravid™; Prociclide™	Antithrombotic Agents	Defibrotide is used to treat or prevent a failure of normal blood flow (occlusive venous disease, OVD) in the liver of patients who have had bone marrow transplants or received certain drugs such as oral estrogens, mercaptopurine, and many others.	36512
Denileukin diftitox	Ontak™	Antineoplastic Agents	For treatment of cutaneous T-cell lymphoma	61118
Desmopressin	Adiuretin™; Concentraid™; Stimate™	Antidiuretic Agents; Hemostatics; Renal Agents	For the management of primary nocturnal enuresis and indicated as antidiuretic replacement therapy in the management of central diabetes insipidus and for the management of the temporary polyuria and polydipsia following head trauma or surgery in the pitu	46800
Dexamethasone	Ozurdex™ (Allergan)	Glucocorticoid	DME, inflammation, macular edema following branch retinal vein occlusion (BRVO) or central retinal vein occlusion	392



Table 1A. Therapeutic Agent List

Generic Name	Brands (Companies)	Category	Indication	Molecular Weight
			(CRVO)	
Diclofenac		Cyclooxygenase Inhibitors		
Dithiocarbamate		NFκB Inhibitor		
Dornase Alfa	Dilor™, Dilor-400™, Lufyllin™, Lufyllin-400™, Neothylline™, Pulmozyme™ (Genentech Inc)	Enzyme Replacement Agents	For the treatment of cystic fibrosis.	7656 (double strand)
Drotrecogin alfa	Xigris™, Xigris™ (Eli Lilly & Co)	Antisepsis Agents	For treatment of severe sepsis	267012
Eculizumab	Soliris™, Soliris™ (Alexion Pharmaceuticals)	Complement Cascade Inhibitor (Factor C5)	AMD.	188333
Efalizumab	Raptiva™, Raptiva™ (Genentech Inc)	Immunomodulatory Agents; Immunosuppressive Agents	For the treatment of adult patients with moderate to severe chronic plaque psoriasis, who are candidates for phototherapy or systemic therapy.	128771
Endostatin				
Enfuvirtide	Fuzeon™, Fuzeon™ (Roche Pharmaceuticals)	Anti-HIV Agents; HIV Fusion Inhibitors	For treatment of HIV AIDS	16768
Epoetin alfa	Epogen™ (Amgen Inc.); Epogin™ (Chugai); Epomax™ (Elanex); Eprex™ (Janssen-Cilag. Ortho	Antianemic Agents	For treatment of anemia (from renal transplants or certain HIV treatment)	55066

Table 1A. Therapeutic Agent List

Generic Name	Brands (Companies)	Category	Indication	Molecular Weight
	Biologics LLC; NeoRecormon™ (Roche); Procrit™ (Ortho Biotech); Recormon™ (Roche)			
Eptifibatid	Integrilin™; Integrilin™ (Millennium Pharm)	Anticoagulants; Antiplatelet Agents; Platelet Aggregation Inhibitors	For treatment of myocardial infarction and acute coronary syndrome.	7128
Erlotinib		Tyrosine Kinase Inhibitors		393
Etanercept	Enbrel™; Enbrel™ (Immunex Corp)	Antirheumatic Agents; Immunomodulatory Agents	Uveitis, AMD	25645
Everolimus		Limus Immunophilin Binding Compounds		
Exenatide	Byetta™; Byetta™ (Amylin/Eli Lilly)		Indicated as adjunctive therapy to improve glycemic control in patients with Type 2 diabetes mellitus who are taking metformin, a sulfonylurea, or a combination of both, but have not achieved adequate glycemic control.	53060
FCFD4514S	Genentech/Roche	Complement Cascade Inhibitor (Factor D)	AMD, Geographic Atrophy	
Felypressin	Felipresina™ [INN-Spanish]; Felypressina™ [DCIT]; Felypressin™ [USAN;BAN;INN]; Felypressine™ [INN-French]; Felypressinum™ [INN-Latin]; Octapressin	Renal Agents; Vasoconstrictor Agents	For use as an alternative to adrenaline as a 143occalizing agent, provided that local ischaemia is not essential.	46800

Table 1A. Therapeutic Agent List

Generic Name	Brands (Companies)	Category	Indication	Molecular Weight
Fenretinide	(Sirion Therapeutics)	Binding Protein Antagonist for Oral Vitamin A	AMD	
Filgrastim	Neupogen™ (Amgen Inc.)	Anti-Infective Agents; Antineutropenic Agents; Immunomodulatory Agents	Increases leukocyte production, for treatment in non-myeloid cancer, neutropenia and bone marrow transplant	28518
FK605-binding proteins, FKBP5		Limus Immunophilin Binding Compounds		
Fluocinolone Acetonide	Retisert™ (Bausch & Lomb); Iluvien™ (Alimera Sciences, Inc.)	Glucocorticoid	Retinal inflammation, diabetic macular edema	453
Follitropin beta	Follistim™ (Organon); Gonal F™, Gonal-F™	Fertility Agents	For treatment of female infertility	78296
Fumagillin				
Galsulfase	Naglazyme™, Naglazyme™ (BioMarin Pharmaceuticals)	Enzyme Replacement Agents	For the treatment of adults and children with Mucopolysaccharidosis VI.	47047
Gefitinib		Tyrosine Kinase Inhibitors		447
Gemtuzumab ozogamicin	Mylotarg™, Mylotarg™ (Wyeth)	Antineoplastic Agents	For treatment of acute myeloid leukemia	39826
Glatiramer Acetate	Copaxone™	Adjuvants, Immunologic; Immunosuppressive Agents	For reduction of the frequency of relapses in patients with Relapsing-Remitting Multiple Sclerosis.	29914

Table 1A. Therapeutic Agent List

Generic Name	Brands (Companies)	Category	Indication	Molecular Weight
Glucagon recombinant	GlucaGen™ (Novo Nordisk); Glucagon™ (Eli Lilly)	Antihypoglycemic Agents	For treatment of severe hypoglycemia, also used in gastrointestinal imaging	54009
Goserelin	Zoladex™	Antineoplastic Agents; Antineoplastic Agents, Hormonal	Breast cancer; Prostate carcinoma; Endometriosis	78617
Human Serum Albumin	Albutein™ (Alpha Therapeutic Corp)	Serum substitutes	For treatment of severe blood loss, hypervolemia, hypoproteinemia	39000
Hyaluronidase	Vitragan™; Vitrase™; Vitrase™ (Ista Pharma)	Anesthetic Adjuvants; Permeabilizing Agents	For increase of absorption and distribution of other injected drugs and for rehydration	69367
Ibritumomab	Zevalin™ (IDEC Pharmaceuticals)	Antineoplastic Agents	For treatment of non-Hodgkin's lymphoma	33078
Idursulfase	Elaprase™ (Shire Pharmaceuticals)	Enzyme Replacement Agents	For the treatment of Hunter syndrome in adults and children ages 5 and older.	47047
Imatinib		Tyrosine Kinase Inhibitors	AMD, DME	494
Immune globulin	Civacir™; Flebogamma™ (Istituto Grifols SA); Gamunex™ (Talecris Biotherapeutics)	Anti-infectives; Immunomodulatory Agents	For treatment of immunodeficiencies, thrombocytopenic purpura, Kawasaki disease, gammablobulinemia, leukemia, bone transplant	42632
Infliximab	Remicade™ (Centocor Inc)	Immunomodulatory Agents; Immunosuppressive Agents	Uveitis, AMD	25645

Table 1A. Therapeutic Agent List

Generic Name	Brands (Companies)	Category	Indication	Molecular Weight
Insulin Glargine recombinant	Lantus™	Hypoglycemic Agents	For treatment of diabetes (type I and II)	156308
Insulin Lyspro recombinant	Humalog™ (Eli Lilly); Insulin Lispro (Eli Lilly)	Hypoglycemic Agents	For treatment of diabetes (type I and II)	154795
Insulin recombinant	Novolin R™ (Novo Nordisk)	Hypoglycemic Agents	For treatment of diabetes (type I and II)	156308
Insulin, porcine	letin II™	Hypoglycemic Agents	For the treatment of diabetes (type I and II)	156308
Interferon				
Interferon Alfa-2a, Recombinant	Roferon A™ (Hoffmann-La Roche Inc); Veldona™ (Amarillo Biosciences)	Antineoplastic Agents; Antiviral Agents	For treatment of chronic hepatitis C, hairy cell leukemia, AIDS-related Kaposi's sarcoma, and chronic myelogenous leukemia. Also for the treatment of oral warts arising from HIV infection.	57759
Interferon Alfa-2b, Recombinant	Intron A™ (Schering Corp)	Antineoplastic Agents; Antiviral Agents; Immunomodulatory Agents	For the treatment of hairy cell leukemia, malignant melanoma, and AIDS-related Kaposi's sarcoma.	57759
Interferon alfacon-1	Advaferon™; Infergen™ (InterMune Inc)	Antineoplastic Agents; Antiviral Agents; Immunomodulatory Agents	For treatment of hairy cell leukemia, malignant melanoma, and AIDS-related Kaposi's sarcoma	57759
Interferon alfa-n1	Wellferon™ (GlaxoSmithKline)	Antiviral Agents; Immunomodulatory Agents	For treatment of venereal or genital warts caused by the Human Papilloma Virus	57759

Table 1A. Therapeutic Agent List

Generic Name	Brands (Companies)	Category	Indication	Molecular Weight
Interferon alfa-n3	Alferon <sup>TM</sup> (Interferon Sciences Inc.); Alferon LDO <sup>TM</sup> , Alferon N Injection	Antineoplastic Agents; Antiviral Agents; Immunomodulatory Agents	For the intralesional treatment of refractory or recurring external condylomata 147cuminata.	57759
Interferon beta-1b	Betaseron <sup>TM</sup> (Chiron Corp)	Antiviral Agents; Immunomodulatory Agents	For treatment of relapsing/remitting multiple sclerosis	57759
Interferon gamma-1b	Actimmune <sup>TM</sup> ; Actimmune <sup>TM</sup> (InterMune Inc)	Antiviral Agents; Immunomodulatory Agents	For treatment of Chronic granulomatous disease, Osteopetrosis	37835
Lapatinib		Tyrosine Kinase Inhibitors		581
Lepirudin	Refludan <sup>TM</sup>	Anticoagulants; Antithrombotic Agents; Fibrinolytic Agents	For the treatment of heparin-induced thrombocytopenia	70037
Lestaurtinib		Tyrosine Kinase Inhibitors		439
Leuprolide	Eligard <sup>TM</sup> (Atrix Labs/QLT Inc)	Anti-Estrogen Agents; Antineoplastic Agents	For treatment of prostate cancer, endometriosis, uterine fibroids and premature puberty	37731
Lutropin alfa	Luveris <sup>TM</sup> (Serono)	Fertility Agents	For treatment of female infertility	78617
Mecasermin	Increlex <sup>TM</sup> ; Increlex <sup>TM</sup> (Tercica); Iplex		For the long-term treatment of growth failure in pediatric patients with Primary IGFD or with GH gene deletion who have developed neutralizing antibodies to GH. It is not indicated to treat Secondary IGFD resulting from GH deficiency, malnutrition, hypothy	154795

Table 1A. Therapeutic Agent List

Generic Name	Brands (Companies)	Category	Indication	Molecular Weight
Menotropins	Repronex™	Fertility Agents	For treatment of female infertility	78617
Methotrexate		Immunomodulatory	Uveitis, DME	
mTOR inhibitors				
Muromonab	Orthoclone OKT3™ (Ortho Biotech)	Immunomodulatory Agents; Immunosuppressive Agents	For treatment of organ transplant recipients, prevention of organ rejection	23148
Natalizumab	Tysabri™	Immunomodulatory Agents	For treatment of multiple sclerosis.	115334
Nepafenac		Cyclooxygenase Inhibitors		
Nesiritide	Natrecor™	Cardiac drugs	For the intravenous treatment of patients with acutely decompensated congestive heart failure who have dyspnea at rest or with minimal activity.	118921
Nilotinib		Tyrosine Kinase Inhibitors		530
NS398		Cyclooxygenase Inhibitors		

Table 1A. Therapeutic Agent List

Generic Name	Brands (Companies)	Category	Indication	Molecular Weight
Octreotide	Atrigel™, Longastatin™, Sandostatatin™, Sandostatatin LAR™, Sandostatatin LAR™ (Novartis)	Anabolic Agents; Antineoplastic Agents, Hormonal; Gastrointestinal Agents; Hormone Replacement Agents	For treatment of acromegaly and reduction of side effects from cancer chemotherapy	42687
Omalizumab	Xolair™ (Genentech Inc)	Anti-Asthmatic Agents; Immunomodulatory Agents	For treatment of asthma caused by allergies	29596
Oprelvekin	Neumega™; Neumega™ (Genetics Institute Inc)	Coagulants; Thrombotics	Increases reduced platelet levels due to chemotherapy	45223
OspA lipoprotein	LYMERix™ (SmithKline Beecham)	Vaccines	For prophylactic treatment of Lyme Disease	95348
OT-551	(Othera)	Anti-oxidant eyedrop	AMD	
Oxytocin	Oxytocin™ (BAM Biotech); Pitocin™ (Parke-Davis); Syntocinon™ (Sandoz)	Anti-tocolytic Agents; Labor Induction Agents; Oxytocics	To assist in labor, elective labor induction, uterine contraction induction	12722
Palifermin	Kepivance™ (Amgen Inc)	Antimucositis Agents	For treatment of mucositis (mouth sores)	138885
Palivizumab	Synagis™	Antiviral Agents	For treatment of respiratory diseases caused by respiratory syncytial virus	63689
Panitumumab	Vectibix™; Vectibix™ (Amgen)	Antineoplastic Agents	For the treatment of EGFR-expressing, metastatic colorectal carcinoma with disease progression on or following fluoropyrimidine-, oxaliplatin-, and irinotecan-containing chemotherapy regimens.	134279



Table 1A. Therapeutic Agent Lis

Generic Name	Brands (Companies)	Category	Indication	Molecular Weight
PDGF inhibitor	(Jerini Ophthalmic); (Ophthotech)	Inhibitors of PDGF	AMD	
PEDF (pigment epithelium derived factor)				
Pegademase bovine	Adagen™ (Enzon Inc.)	Enzyme Replacement Agents	For treatment of adenosine deaminase deficiency	36512
Pegaptanib	Macugen™	Oligonucleotide	For the treatment of neovascular (wet) age-related macular degeneration.	103121
Pegaspargase	Oncaspar™ (Enzon Inc)	Antineoplastic Agents	For treatment of acute lymphoblastic leukemia	132.118
Pegfilgrastim	Neulasta™ (Amgen Inc.)	Anti-Infective Agents; Antineutropenic Agents; Immunomodulatory Agents	Increases leukocyte production, for treatment in non-myeloid cancer, neutropenia and bone marrow transplant	28518
Peginterferon alfa-2a	Pegasys™ (Hoffman-La Roche Inc)	Antineoplastic Agents; Antiviral Agents; Immunomodulatory Agents	For treatment of hairy cell leukemia, malignant melanoma, and AIDS-related Kaposi's sarcoma.	57759
Peginterferon alfa-2b	PEG-Intron (Schering Corp); Unitron PEG™	Antineoplastic Agents; Antiviral Agents; Immunomodulatory Agents	For the treatment of chronic hepatitis C in patients not previously treated with interferon alpha who have compensated liver disease and are at least 18 years of age.	57759
Pegvisomant	Somavert™ (Pfizer Inc)	Anabolic Agents; Hormone Replacement Agents	For treatment of acromegaly	71500

Table 1A. Therapeutic Agent List

Generic Name	Brands (Companies)	Category	Indication	Molecular Weight
Pentoxifylline				
Perindozril		ACE Inhibitors		
Pimecrolimus		Limus Immunophilin Binding Compounds		
PKC (protein kinase C) inhibitors				
POT-4	Potential/Alcon	Complement Cascade Inhibitor (Factor C3)	AMD	
Pramlintide	Symlin™, Symlin™ (Amylin Pharmaceuticals)		For the mealtime treatment of Type I and Type II diabetes in combination with standard insulin therapy, in patients who have failed to achieve adequate glucose control on insulin monotherapy.	16988
Proteasome inhibitors	Velcade™		Proteasome inhibitors	
Pyrrolidine				
Quinopri		ACE Inhibitors		

Table 1A. Therapeutic Agent List

Generic Name	Brands (Companies)	Category	Indication	Molecular Weight
Ranibizumab	Lucentis™		For the treatment of patients with neovascular (wet) age-related macular degeneration.	27043
Rapamycin (sirolimus)	(MacuSight)	Limus Immunophilin Binding Compounds	AMD	
Rasburicase	Elitek™, Elitek™ (Sanofi-Synthelabo Inc); Fasturtec™	Antihyperuricemic Agents	For treatment of hyperuricemia, reduces elevated plasma uric acid levels (from chemotherapy)	168.11
Reteplase	Retavase™ (Centocor); Retavase™ (Roche)	Thrombolytic Agents	For lysis of acute pulmonary emboli, intracoronary emboli and management of myocardial infarction	54732
Retinal stimulant	Neurosolve™ (Vitreoretinal Technologies)	Retinal stimulants	AMD	
Retinoid(s)				
Rituximab	MabThera™; Rituxan™	Antineoplastic Agents	For treatment of B-cell non-Hodgkins lymphoma (CD20 positive)	33078
RNAI (RNA interference of angiogenic factors)				
Rofecoxib	Vioxx™, Ceoxx™, Ceeoxx™ (Merck & Co.)	Cyclooxygenase Inhibitors		
Rosiglitazone		Thiazolidinediones		

Table 1A. Therapeutic Agent List

Generic Name	Brands (Companies)	Category	Indication	Molecular Weight
Ruboxistaurin	Eli Lilly	Protein Kinase C (PKC)-b Inhibitor	DME, diabetic peripheral retinopathy	469
Salmon Calcitonin	Calcimar™; Miacalcin™ (Novartis)	Antihypocalcemic Agents; Antiestrogenic Agents; Bone Density Conservation Agents	For the treatment of post-menopausal osteoporosis	57304
SAR 1118	SARCode	Immunomodulatory Agent	Dry eye, DME, conjunctivitis	
Sargramostim	Immunex™; Leucomax™ (Novartis); Leukine™; Leukine™ (Berlex Laboratories Inc)	Anti-Infective Agents; Antineoplastic Agents; Immunomodulatory Agents	For the treatment of cancer and bone marrow transplant	46207
SDZ-RAD		Limus Immunophilin Binding Compounds		
Secretin	SecreFlo™; Secremax™, SecreFlo™ (Repligen Corp)	Diagnostic Agents	For diagnosis of pancreatic exocrine dysfunction and gastrinoma	50207
Selective inhibitor of the factor 3 complement cascade				
Selective inhibitor of the factor 5 complement cascade				
Semaxanib		Tyrosine Kinase Inhibitors		238

Table 1A. Therapeutic Agent List

Generic Name	Brands (Companies)	Category	Indication	Molecular Weight
Sermorelin	Geref™ (Serono Pharma)	Anabolic Agents; Hormone Replacement Agents	For the treatment of dwarfism, prevention of HIV-induced weight loss	47402
Serum albumin iodinated	Megatope™ (IsoTex Diagnostics)	Imaging Agents	For determination of total blood and plasma volumes	39000
SF1126	Semafore	PI3k/mTOR Inhibition	AMD, DME	
Sirolimus reformulation (rapamycin)	(MacuSight)	Limus Immunophilin Binding Compounds	AMD	
siRNA molecule synthetic, FTP-8011-14	(Quark Pharmaceuticals)	siRNAi molecule.synthetic	AMD	
Somatropin recombinant	BioTropin™ (Biotech General); Genotropin™ (Pizer); Humatrope™ (Eli Lilly); Norditropin™ (Novo Nordisk); Nutropin™ (Genentech Inc.); NutropinAQ™ (Genentech Inc.); Protropin™ (Genentech Inc.); Saizen™ (Serono SA); Serostim™; Serostim™ (Serono SA); Tev-Tropin™ (GATE)	Anabolic Agents; Hormone Replacement Agents	For treatment of dwarfism, acromegaly and prevention of HIV-induced weight loss	71500
Squalamine				
Streptokinase	Streptase™ (Aventis Behringer GmbH)	Thrombolytic Agents	For the treatment of acute evolving transmural myocardial infarction, pulmonary embolism, deep vein thrombosis, arterial thrombosis or embolism and occlusion of arteriovenous	90569

Table 1A. Therapeutic Agent List

Generic Name	Brands (Companies)	Category	Indication	Molecular Weight
Sunitinib		Tyrosine Kinase Inhibitors	cannulae	398
TA106	Taligen	Complement Cascade Inhibitor (Factor B)	AMD	
Tacrolimus		Limus Immunophilin Binding Compounds		
Tenecteplase	TNKase™ (Genentech Inc)	Thrombolytic Agents	For treatment of myocardial infarction and lysis of intracoronary emboli	54732
Teriparatide	Aphela™, Forsteo™, Forteo™, Fortessa™, Ophtha™, Optia™, Optiah™, Zaletra™, Zelletra™	Bone Density Conservation Agents	For the treatment of osteoporosis in men and postmenopausal women who are at high risk for having a fracture. Also used to increase bone mass in men with primary or hypogonadal osteoporosis who are at high risk for fracture.	66361
Tetrathiomolybdate				
Thalidomide	Celgene	Anti-inflammatory, Anti-proliferative	Uveitis	
Thyrotropin Alfa	Thyrogen™ (Genzyme Inc)	Diagnostic Agents	For detection of residueal or recurrent thyroid cancer	86831

Table 1A. Therapeutic Agent List

Generic Name	Brands (Companies)	Category	Indication	Molecular Weight
Tie-1 and Tie-2 kinase inhibitors				
Toceranib		Tyrosine Kinase Inhibitors		396
Tositumomab	Bexxar™ (Corixa Corp)	Antineoplastic Agents	For treatment of non-Hodgkin's lymphoma (CD20 positive, follicular)	33078
TPN 470 analogue				
Trastuzumab	Herceptin™ (Genentech)	Antineoplastic Agents	For treatment of HER2-positive pulmonary breast cancer	137912
Triamcinolone acetonide	Trience™	Glucocorticoid	DME, For treatment of inflammation of the retina	435
Troglitazone		Thiazolidinediones		
Tumistatin				
Urofollitropin	Fertinex™ (Serono S.A.)	Fertility Agents	For treatment of female infertility	78296
Urokinase	Abbokinase™; Abbokinase™ (Abbott Laboratories)	Thrombolytic Agents	For the treatment of 156ulmonary embolism, coronary artery thrombosis and IV catheter clearance	90569

Table 1A. Therapeutic Agent List

Generic Name	Brands (Companies)	Category	Indication	Molecular Weight
Vandetanib		Tyrosine Kinase Inhibitors		475
Vasopressin	Pitressin™; Pressyn™	Antidiuretics; Oxytocics; Vasoconstrictor Agents	For the treatment of enuresis, polyuria, diabetes insipidus, polydipsia and oesophageal varices with bleeding	46800
Vatalanib		Tyrosine Kinase Inhibitors		347
VEGF receptor kinase inhibitor				
VEGF Trap	Aflibercept™ (Regeneron Pharmaceuticals, Bayer HealthCare AG)	Genetically Engineered Antibodies	DME, cancer, retinal vein occlusion, choroidal neovascularization, delay wound healing, cancer treatment	96600
Visual Cycle Modulator ACU-4229	(Acucela)	Visual Cycle Modulator	AMD	
Vitamin(s)				
Vitronectin receptor antagonists				
Volociximab	Ophthotech	alpha5beta1 Integrin Inhibitor	AMD	
XL765	Exelixis/Sanofi-Aventis	PI3k/mTOR Inhibition	AMD, DME	



WHAT IS CLAIMED IS:

- 1                   1.     A method of treating an eye having a sclera and a vitreous humor, the  
2     method comprising:  
3                    delivering a first therapeutic amount of a first therapeutic agent to the vitreous  
4     humor of the eye, the first therapeutic agent effective for a first extended time; and  
5                    delivering a second therapeutic amount of a second therapeutic agent, the second  
6     therapeutic agent effective for a second extended time.  
7
- 1                   2.     The method of claim 1, wherein the first therapeutic agent comprises an  
2     antineoplastic agent and effective for the first extended time and wherein the second  
3     therapeutic agent comprises one or more of a COX inhibitor, a LOX inhibitor, a TNF inhibitor,  
4     or an antihistamine.
- 1                   3.     The method of claim 1, wherein the first therapeutic agent comprises a  
2     vascular growth inhibitor effective for the first extended time and wherein the second  
3     therapeutic agent comprises an inflammatory response inhibitor effective for a second extended  
4     time.
- 1                   4.     The method of claim 3, wherein the vascular growth inhibitor  
2     comprising one or more of a VEGF inhibitor,
- 1                   5.     The method of claim 3, wherein the inflammatory response inhibitor  
2     comprises a cyclooxygenase (hereinafter "COX") inhibitor;
- 1                   6.     The method of claim 5, wherein the COX inhibitor comprises one or  
2     more of a salicylic acid derivative, a propionic acid derivative, an acetic acid derivative, and  
3     enolic acid (hereinafter "Oxicam") derivative, a fenamic acid derivative, a selective COX-2  
4     inhibitor (hereinafter "Coxibs").
- 1                   7.     The method of claim 6, wherein the inflammatory response inhibitor  
2     comprises the propionic acid derivative and wherein the propionoic acid inhibitor comprises  
3     one or more of Ibuprofen, Naproxen, Fenoprofen, Ketoprofen, Flurbiprofen or Oxaprozin.

1           8.     The method of claim 6, wherein the inflammatory response inhibitor  
2 comprises the acetic acid derivative and wherein the acetic acid derivative comprises one or  
3 more of Indomethacin, Sulindac, Etodolac, Diclofenac or Nabumetone.

1           9.     The method of claim 6, wherein the inflammatory response inhibitor  
2 comprises the Enolic acid (hereinafter "Oxicam") derivatives and wherein the Enolic acid  
3 derivative comprises one or more of Piroxicam, Meloxicam, Tenoxicam, Droxicam,  
4 Lornoxicam, or Isoxicam.

1           10.    The method of claim 6, wherein the inflammatory response inhibitor  
2 comprises the Fenamic acid derivative and wherein the Fenamic acid derivative comprises one  
3 or more of Mefenamic acid, Meclofenamic acid, Flufenamic acid, or Tolfenamic acid.

1           11.    The method of claim 6, wherein the inflammatory response inhibitor  
2 comprises the Selective COX-2 inhibitor (hereinafter "Coxibs") and wherein the Selective  
3 COX-2 inhibitor comprises one or more of Celecoxib, Rofecoxib, Valdecoxib, Parecoxib,  
4 Lumiracoxib, or Etoricoxib.

1           12.    The method of claim 3, wherein the first therapeutic agent is injected  
2 into the vitreous humor of the eye.

1           13.    The method of claim 3, wherein the second therapeutic agent is injected  
2 into the vitreous humor of the eye.

1           14.    The method of claim 3, further comprising:  
2           introducing a container at least partially through the sclera to couple the  
3 container to the vitreous humor and the sclera.

1           15.    The method of claim 14, wherein the first therapeutic agent is injected  
2 into a chamber of the container when the container is coupled to the vitreous humor and the  
3 sclera and wherein the container is configured with a porous structure and a volume to release  
4 the first therapeutic amounts of the first therapeutic agent from the chamber into the vitreous  
5 humor for the first extended time.

1                   16.     The method of claim 14, wherein the second therapeutic agent is injected  
2 into a chamber of the container when the container is coupled to the vitreous humor and the  
3 sclera.

1                   17.     The method of claim 15, wherein the first therapeutic agent comprises a  
2 VEGF inhibitor and the second therapeutic agent comprises a cyclooxygenase inhibitor.

1                   18.     The method of claim 17, wherein the cyclooxygenase inhibitor  
2 comprises a solid coupled to the container to release the second therapeutic agent for the  
3 extended time.

1                   19.     The method of claim 18, wherein the solid cyclooxygenase inhibitor is  
2 located within the chamber of the container and released through the porous structure.

1                   20.     The method of claim 18, wherein the solid cyclooxygenase inhibitor is  
2 located within a second chamber of the container and released through a second porous  
3 structure.

1                   21.     The method of claim 20, wherein the second chamber is separated from  
2 the first chamber.

1                   22.     The method of claim 20, wherein the second chamber is coupled to the  
2 first chamber with the first porous structure and coupled to the vitreous with the second porous  
3 structure such that the first therapeutic agent passes through the first porous structure and  
4 second porous structure to reach the vitreous humor.

1                   23.     The method of claim 18, wherein the solid cyclooxygenase inhibitor is  
2 located away from the chamber and coupled to the vitreous humor.

1                   24.     The method of claim 14, wherein the container is configured to release  
2 the therapeutic amounts of the first therapeutic agent into the vitreous humor for the first  
3 extended time.

1                   25.     The method of claim 1, wherein the first therapeutic agent comprises a  
2 vascular growth inhibitor effective for the first extended time and wherein the second

3 therapeutic agent comprises a lipoxygenase pathway (hereinafter "LOX") inhibitor effective for  
4 the second extended time.

1 26. The method of claim 25, wherein the LOX inhibitor comprises a 5-LOX  
2 inhibitor.

1 27. The method of claim 1, wherein the first therapeutic agent comprises a  
2 vascular growth inhibitor effective for the first extended time and wherein the second  
3 therapeutic agent comprises an antifibrotic agent effective for the second amount of time.

1 28. The method of claim 1, wherein the first therapeutic agent comprises a  
2 vascular growth inhibitor effective for the first extended time and wherein the second  
3 therapeutic agent comprises a tumor necrosis factor (hereinafter "TNF") inhibitor effective for  
4 the second extended time.

1 29. The method of claim 28, wherein the TNF inhibitor comprises  
2 pentoxifylline effective for the second extended time.

1 30. The method of claim 1, wherein the first therapeutic agent comprises a  
2 vascular growth inhibitor effective for the first extended time and wherein the second  
3 therapeutic agent comprises a dual COX/LOX inhibitor effective for the second extended time.

1 31. The method of claim 30, wherein the dual COX/LOX inhibitor  
2 comprises Licofelone .

1 32. The method of claim 1, wherein the first therapeutic agent comprises a  
2 vascular growth inhibitor effective for the first extended time and wherein the second  
3 therapeutic agent comprises an antihistamine.

1 33. The method of claim 30, wherein the antihistamine comprises azelastine.

1 34. The method of claim 30, wherein the antihistamine comprises an H1-  
2 receptor antagonist.

1 35. The method of claim 34, wherein H1-receptor antagonist comprises one  
2 or more of Clemastine, Diphenhydramine (Benadryl), Doxylamine, Loratadine, Desloratadine,  
3 Fexofenadine, Pheniramine, Cetirizine, Ebastine, Promethazine, Chlorpheniramine,

4 Levocetirizine, Olopatadine, Quetiapine, Meclizine, Dimenhydrinate, embramine,  
5 dimethindene, or dexchlorpheniramine.

1 36. The method of claim 30, wherein the antihistamine comprises an H2-  
2 receptor antagonist.

1 37. The method of claim 36, wherein H2-receptor antagonist comprises one  
2 or more of Cimetidine, Famotidine, Ranitidine, Nizatidine, Roxatidine, Lafutidine.

1 38. The method of claim 30, wherein the antihistamine comprises an H3-  
2 receptor antagonist.

1 39. The method of claim 38, wherein H3-receptor antagonist comprises one  
2 or more of A-349,821, ABT-239, Ciproxifan, Clobenpropit, or Thioperamide.

1 40. The method of claim 30, wherein the antihistamine comprises an H4-  
2 receptor antagonist.

1 41. The method of claim 40, wherein H4-receptor antagonist comprises one  
2 or more of Thioperamide, JNJ 7777120, or VUF-6002.

1 42. An apparatus to treat an eye having a sclera and a vitreous humor, the  
2 apparatus comprising:

3 a therapeutic device configured to couple to the sclera and comprising a first  
4 container to hold a first therapeutic agent, the first container having a second therapeutic agent  
5 with in the container to release therapeutic amounts of the second therapeutic agent into the  
6 vitreous humor for a second extended time when the therapeutic device is inserted into the eye.

1 43. An apparatus to treat an eye having a sclera and a vitreous humor, the  
2 apparatus comprising:

3 a therapeutic device configured to couple to the sclera and comprising a first  
4 container to hold a first therapeutic agent and a second container to hold a second therapeutic  
5 agent, the first container configured to release first therapeutic amounts of the first therapeutic  
6 agent into the vitreous humor for a first extended time, the second container configured to  
7 release second therapeutic amounts of the second therapeutic agent into the vitreous humor for  
8 a second extended time.

1           44.    An apparatus to treat an eye having a sclera and a vitreous humor, the  
2 apparatus comprising:

3                   a first therapeutic device comprising first container configured to couple to the  
4 sclera and hold a first therapeutic agent, the first container configured to release first  
5 therapeutic amounts of the first therapeutic agent into the vitreous humor for a first extended  
6 time; and

7                   a second therapeutic device comprising a second container configured to couple  
8 to the sclera and hold a second therapeutic agent, the second container configured to release  
9 second therapeutic amounts of the second therapeutic agent into the vitreous humor for a  
0 second extended time.

1           45.    The apparatus of any one of claims 44, wherein the first therapeutic  
2 device and the second therapeutic device each comprises a portion to couple to the sclera  
3 having an oval cross section sized to fit an incision extending along the pars plana.

1           46.    The apparatus of any one of claims 42, 43, or 44, wherein the first  
2 therapeutic agent comprises a VEGF inhibitor and the second therapeutic agent comprises a  
3 COX inhibitor.

1           47.    The apparatus of claim 46 wherein the therapeutic device comprises a  
2 first chamber to receive an injection of the first therapeutic agent, the first chamber coupled to a  
3 first porous structure to contain the first therapeutic agent and release therapeutic amounts of  
4 the first therapeutic agent with a first release rate profile for the first extended time.

1           48.    The apparatus of claim 47 wherein the COX inhibitor comprises a water  
2 insoluble COX inhibitor to release the therapeutic agent with a second release rate profile for  
3 the second extended time.

1           49.    The apparatus of claim 48 further comprising a second chamber to the  
2 water insoluble COX inhibitor and a second porous structure coupled to the second chamber to  
3 release the water insoluble COX inhibitor through the second porous structure.

4           50.    The apparatus of claim 49 wherein the first chamber is coupled to the  
5 second chamber with the first porous structure, the first porous structure having a first release

6 rate index, the second porous structure having a second release rate index, wherein the first  
7 release rate index is smaller than the second release rate index, such that the release rate profile  
8 of the first therapeutic agent is determined substantially based on the first release rate index and  
9 the release rate profile of the second therapeutic agent is determined substantially based on the  
0 second release rate index.

1 51. A therapeutic device to treat a patient, the device comprising:  
2 means for releasing therapeutic amounts of a therapeutic agent for an extended  
3 period.

1 52. A sustained drug delivery formulation comprising a first and second  
2 therapeutic agent wherein the first and second therapeutic agent is contained/disposed in a  
3 reservoir in at least one apparatus/therapeutic device of any one of claims 42 to 51, and at least  
4 one of the first and second therapeutic agent has a half-life within the reservoir when  
5 implanted, the half life within the reservoir substantially greater than a corresponding half-life  
6 of the at least one of the first and second therapeutic agent when injected directly into the  
7 vitreous of an eye.

1 53. The formulation of claim 52, wherein the device can be configured by  
2 selection of the reservoir volume and a porous structure with an appropriate rate release index  
3 to achieve the desired effective half-life.

1 54. The formulation of claim 53, wherein the rate release index is from about  
2 0.01 to about 5.

1 55. The formulation of claim 52, wherein the first therapeutic agent is a  
2 VEGF-inhibitor and the second therapeutic agent is an inflammatory response inhibitor.

1 56. The formulation of claim 55, wherein the VEGF inhibitor is selected  
2 from the group consisting of Ranibizumab, Bevacizumab and Aflibercept<sup>TM</sup>

1 57. The formulation of claim 56, wherein the VEGF inhibitor is  
2 Ranibizumab.

1           58.    The formulation of claim 55, wherein the inflammatory response  
2 inhibitor is selected from the group consisting of Piroxicam, Meloxicam, Tenoxicam,  
3 Droxicam, Lornoxicam, Isoxicam, Mefenamic acid, Meclofenamic acid, Flufenamic acid, and  
4 Tolfenamic acid.

1           59.    The formulation of claim 55, wherein the inflammatory response  
2 inhibitor is selected from the group consisting of a cyclooxygenase (COX) inhibitor, a  
3 lipoxygenase (LOX) inhibitor and a tumor necrosis factor (TNF).

1           60.    The formulation of claim 59, wherein the cox inhibitor is selected from  
2 the group consisting of celecoxib, valdecoxib, rofecoxib, parecoxib, lumiracoxib, etoricoxib,  
3 aspirin, ibuprofen, naproxen, fenoprofen, ketoprofen, flurbiprofen, oxaprozin, indomethacin,  
4 sulindac, etodolac, diclofenac, nabumetone, meloxicam, ketalorac, flurbiprofen, bromfenac,  
5 nepafenac, and amfenac.

1           61.    The formulation of claim 59, wherein the lox inhibitor is selected from  
2 the group consisting of azelastine and zileuton.

1           62.    The formulation of claim 59, wherein the TNF is selected from the group  
2 consisting of bupropion, pentoxifylline, infliximab, adalimumab, and etanercept.

1           63.    The formulation of claim 57, wherein the concentration of the first  
2 therapeutic agent is greater than about 40 mg/ml.

1           64.    The formulation of claim 63, wherein the concentration of the first  
2 therapeutic agent is from about 50 mg/ml to about 300 mg/ml.

1           65.    The formulation of claim 64, wherein the concentration of the first  
2 therapeutic agent is about 100 mg/ml to about 250 mg/ml.

1           66.    The formulation of claim 65, wherein the concentration of the first  
2 therapeutic agent is about 150 mg/ml to about 200 mg/ml.



1           67.    The formulation of claim 57, wherein the amount of the first therapeutic  
2 agent is greater than about 50 mg.

1           68.    The formulation of claim 52, wherein at least one of the first or second  
2 therapeutic agent is administered in a sub-therapeutic dosage.

1           69.    The formulation of claim 52, wherein at least one of the first or second  
2 therapeutic agent is contained/disposed in a micelle.

1           70.    The formulation of claim 52, wherein at least one of the first and second  
2 therapeutic agent is stabilized by adsorption onto solid substrate or macromolecule that is  
3 capable of being flushed from the eye.

1           71.    The formulation of claim 52, wherein the first and second therapeutic  
2 agents are contained/disposed in one apparatus/therapeutic device.

1           72.    The formulation of claim 52, wherein the first therapeutic agent is  
2 contained/disposed in a first apparatus/therapeutic device and the second therapeutic agent is  
3 contained/disposed in a second apparatus/therapeutic device.

1           73.    The formulation of claim 52, wherein the first and second therapeutic  
2 agents are administered simultaneously.

1           74.    The formulation of claim 52, wherein the first and second therapeutic  
2 agents are administered sequentially.

1

Table 1A. Therapeutic Agent List

Generic Name	Brands (Companies)	Category	Indication	Molecular Weight
2-Methoxyestradiol analogs	(Paloma Pharmaceuticals)	Angiogenesis inhibitors	AMD	
3-aminothalidomide				
13-cis retinoic acid	Accutane TM (Roche Pharmaceuticals)			
A0003	(Aqumen BioPharmaceuticals)	A0003	AMD	
A5b1 integrin inhibitor	(Jerrini Ophthalmic); (Ophthotech)	Inhibitors of a5b1 integrin	AMD	
Abarelix	Plenaxis <sup>TM</sup> (Praecis Pharmaceuticals)	Anti-Testosterone Agents; Antineoplastic Agents	For palliative treatment of advanced prostate cancer.	37731
Abatacept	Orencia <sup>TM</sup> (Bristol-Myers Squibb)	Antirheumatic Agents	For the second line reduction of the signs and symptoms of moderate-to-severe active rheumatoid arthritis, inducing major clinical response, slowing the progression of structural damage, and improving physical function in adult patients who have	37697
Abciximab	ReoPro <sup>TM</sup> , ReoPro <sup>TM</sup> (Centocor)	Anticoagulants; Antiplatelet Agents	For treatment of myocardial infarction, adjunct to percutaneous coronary intervention, unstable angina	42632
ABT-578	(Abbott Laboratories)	Limus Immunophilin Binding Compounds		

Table 1A. Therapeutic Agent List

Generic Name	Brands (Companies)	Category	Indication	Molecular Weight
Acetone				
Adalimumab	Humira™ (Abbott Laboratories)	Antirheumatic Agents; Immunomodulatory Agents	Uveitis, AMD	25645
Aldesleukin	Proleukin™; Proleukin™ (Chiron Corp)	Antineoplastic Agents	For treatment of adults with metastatic renal cell carcinoma	61118
Alefacept	Amevive™	Immunomodulatory Agents; Immunosuppressive Agents	For treatment of moderate to severe chronic plaque psoriasis	42632
Alemtuzumab	Campath™; Campath™ (ILEX Pharmaceuticals LP); MabCampath™	Antineoplastic Agents	For treatment of B-cell chronic lymphocytic leukemia	6614
Alpha-1-proteinase inhibitor	Aralast™ (Baxter); Prolastin™ (Talecris Biotherapeutics C formerly Bayer)	Enzyme Replacement Agents	For treatment of panacinar emphysema	28518
Alteplase	Activase™ (Genentech Inc)	Thrombolytic Agents	For management of acute myocardial infarction, acute ischemic stroke and for lysis of acute pulmonary emboli	54732
AMG-1470				
Anakinra	Kineret™ (Amgen Inc)	Anti-Inflammatory Agents, Non-Steroidal; Antirheumatic Agents; Immunomodulatory Agents	For the treatment of adult rheumatoid arthritis.	65403

Table 1A. Therapeutic Agent List

Generic Name	Brands (Companies)	Category	Indication	Molecular Weight
Anecortave acetate				
Angiostatin				
Anistreplase	Eminase™ (Wulfing Pharma GmbH)	Thrombolytic Agents	For lysis of acute pulmonary emboli, intracoronary emboli and management of myocardial infarction	54732
Anti-angiogenesis peptides	(Eyecopharm)	Anti-angiogenesis peptides	AMD	
Anti-angiogenesis antibodies, TRC093, TRC105	(TRACON Pharma)	Anti-angiogenesis antibodies	AMD	
Anti-angiogenic bifunctional protein	Icon-1™ (Iconic Therapeutics)	Anti-angiogenic bifunctional protein, Icon-1	AMD	
Anti-endothelial growth factor				
Antihemophilic Factor	Advate™, Alphanate™, Bioclote™, Helixate™, Helixate FS™, Hemofil M™, Humate-P™, Hyate-C™, Koate-HP™, Kogenate™, Kogenate FS™, Monarc-M™, Monoclate-P™, ReFacto™, Xyntha™	Coagulants; Thrombotic Agents	For the treatment of hemophilia A, von Willebrand disease and Factor XIII deficiency	70037
Antithymocyte globulin	Genzyme; Thymoglobulin™ (SangStat Medical)	Immunomodulatory Agents	For prevention of renal transplant rejection	37173

Table 1A. Therapeutic Agent List

Generic Name	Brands (Companies)	Category	Indication	Molecular Weight
Anti-hypertensive MC1101	(MacuCLEAR)	Anti-hypertensive MC1101	AMD	
Anti-platelet devired growth factor				
Anti-VEGF	(Neurotech); Avastin™ (NeoVista)	Anti-VEGF	AMD	
AP23841	(Ariad)	Limus Immunophilin Binding Compounds		
Aprotinin	Trasylol™	Antifibrinolytic Agents	For prophylactic use to reduce perioperative blood loss and the need for blood transfusion in patients undergoing cardiopulmonary bypass in the course of coronary artery bypass graft surgery who are at an increased risk for blood loss and blood transfusio	90569
Arcitumomab	CEA-Scan™	Diagnostic Agents; Imaging Agents	For imaging colorectal tumors	57561
Asparaginase	Elspar™ (Merck & Co. Inc)	Antineoplastic Agents	For treatment of acute lymphocytic leukemia and non-Hodgkins lymphoma	132.118
Axitinib		Tyrosine Kinase Inhibitors		386
Basiliximab	Simulect™ (Novartis Pharmaceuticals)	Immunomodulatory Agents; Immunosuppressive Agents	For prophylactic treatment of kidney transplant rejection	61118

Table 1A. Therapeutic Agent List

Generic Name	Brands (Companies)	Category	Indication	Molecular Weight
Becaplermin	Regranex™; Regranex™ (OMJ Pharmaceuticals)	Anti-Ulcer Agents; Topical	For topical treatment of skin ulcers (from diabetes)	123969
Bevacizumab	Avastin™; Avastin™ (Genentech Inc)	Antiangiogenesis Agents; Antineoplastic Agents	For treatment of metastatic colorectal cancer	27043
Bivalirudin	Angiomax™; Angiomax™ (Medicines Co or MDCO); Angiox™	Anticoagulants; Antithrombotic Agents	For treatment of heparin-induced thrombocytopenia	70037
Bortezomib		Proteasome Inhibitors		
Bosutinib		Tyrosine Kinase Inhibitors		530
Botulinum Toxin Type A	BOTOX™ (Allergan Inc); BOTOX Cosmetic™ (Allergan Inc); Botox™; Dysport™	Anti-Wrinkle Agents; Antidystonic Agents; Neuromuscular Blocking Agents	For the treatment of cervical dystonia in adults to decrease the severity of abnormal head position and neck pain associated with cervical dystonia. Also for the treatment of severe primary axillary hyperhidrosis that is inadequately managed with topical	23315
Botulinum Toxin Type B	Myobloc™ (Solstice Neurosciences); Neurobloc™ (Solstice Neurosciences)	Antidystonic Agents	For the treatment of patients with cervical dystonia to reduce the severity of abnormal head position and neck pain associated with cervical dystonia.	12902
C5 inhibitor	(Jerrini Ophthalmic) ; (Ophthotech)	Inhibitors of C5	AMD	
Canstatin				

Table 1A. Therapeutic Agent List

Generic Name	Brands (Companies)	Category	Indication	Molecular Weight
Capromab	ProstaScint™ (Cytogen Corp)	Imaging Agents	For diagnosis of prostate cancer and detection of intra-pelvic metastases	84331
Captopril		ACE Inhibitors		
CCI-779	(Wyeth)	Limus Immunophilin Binding Compounds		
Cediranib		Tyrosine Kinase Inhibitors		450
Celecoxib		Cyclooxygenase Inhibitors		
Cetrorelix	Cetrotide™	Hormone Antagonists; Infertility Agents	For the inhibition of premature LH surges in women undergoing controlled ovarian stimulation	78617
Cetuximab	Erbix™; Erbitux™ (ImClone Systems Inc)	Antineoplastic Agents	For treatment of metastatic colorectal cancer.	42632
Choriogonadotropin alfa	Novarel™; Ovidrel™; Pregnyl™; Profasi™	Fertility Agents; Gonadotropins	For the treatment of female infertility	78617
Ciliary neurotrophic factor	(Neurotech)	Ciliary neurotrophic factor	AMD	
Coagulation Factor IX	Benefix™ (Genetics Institute)	Coagulants; Thrombotic Agents	For treatment of hemophilia (Christmas disease).	267012

Table 1A. Therapeutic Agent List

Generic Name	Brands (Companies)	Category	Indication	Molecular Weight
Coagulation factor VIIa	NovoSeven™ (Novo Nordisk)	Coagulants; Thrombotic Agents	For treatment of hemorrhagic complications in hemophilia A and B	54732
Colchicines				
Collagenase	Cordase™, Santyl™ (Advance Biofactures Corp); Xiaflex™	Anti-Ulcer Agents; Topical	For treatment of chronic dermal ulcers and severe skin burns	138885
Complement factor H recombinant	(Optherion); (Taligen Therapeutics)	Complement factor H recombinant	AMD, Geographic Atrophy	
Compstatin derivative peptide, POT-4	(Potentia Pharmaceuticals)	Complement Factor C3 Inhibitors; Compstatin Derivative Peptides	AMD	
Corticotropin	ACTH™, Acethropan™, Acoftan™, Acthar™, Exacthin™, H.P. Acthar Gel™, Isactid™, Purified cortrophin gel™, Reacthin™, Solacthyl™, Tubex Cortrosyn™; Synacthen depot™	Diagnostic Agents	For use as a diagnostic agent in the screening of patients presumed to have adrenocortical insufficiency.	33927
Cosyntropin		Diagnostic Agents	For use as a diagnostic agent in the screening of patients presumed to have adrenocortical insufficiency.	33927
Cyclophilins		Limus Immunophilin Binding Compounds		
Cyclosporine	Gengraf™ (Abbott labs); Neoral™ (Novartis); Restasis™; Restasis™ (Allergan Inc); Sandimmune™ (Novartis); Sangcya™	Antifungal Agents; Antirheumatic Agents; Dermatologic Agents; Enzyme Inhibitors; Immunomodulatory Agents; Immunosuppressive	For treatment of transplant rejection, rheumatoid arthritis, severe psoriasis	32953



Table 1A. Therapeutic Agent List

Generic Name	Brands (Companies)	Category	Indication	Molecular Weight
		Agents		
Daclizumab	Zenapax™ (Hoffmann-La Roche Inc)	Immunomodulatory Agents; Immunosuppressive Agents	For prevention of renal transplant rejection	61118
Darbepoetin alfa	Aranesp™ (Amgen Inc.)	Antianemic Agents	For the treatment of anemia (from renal transplants or certain HIV treatment)	55066
Dasatinib		Tyrosine Kinase Inhibitors		488
Defibrotide	Dasovas™, Noravid™, Proclilide™	Antithrombotic Agents	Defibrotide is used to treat or prevent a failure of normal blood flow (occlusive venous disease, OVD) in the liver of patients who have had bone marrow transplants or received certain drugs such as oral estrogens, mercaptopurine, and many others.	36512
Denileukin diftitox	Ontak™	Antineoplastic Agents	For treatment of cutaneous T-cell lymphoma	61118
Desmopressin	Adiuretin™, Concentraid™, Stimlate™	Antidiuretic Agents; Hemostatics; Renal Agents	For the management of primary nocturnal enuresis and indicated as antidiuretic replacement therapy in the management of central diabetes insipidus and for the management of the temporary polyuria and polydipsia following head trauma or surgery in the pitu	46800
Dexamethasone	Ozurdex™ (Allergan)	Glucocorticoid	DME, inflammation, macular edema following branch retinal vein occlusion (BRVO) or central retinal vein occlusion	392

Table 1A. Therapeutic Agent List

Generic Name	Brands (Companies)	Category	Indication	Molecular Weight
			(CRVO)	
Diclofenac		Cyclooxygenase Inhibitors		
Dithiocarbamate		NFκB Inhibitor		
Dornase Alfa	Dilor™, Dilor-400™, Lufyllin™, Lufyllin-400™, Neothylline™, Pulmozyme™ (Genentech Inc)	Enzyme Replacement Agents	For the treatment of cystic fibrosis.	7656 (double strand)
Drotrecogin alfa	Xigris™, Xigris™ (Eli Lilly & Co)	Antisepsis Agents	For treatment of severe sepsis	267012
Eculizumab	Soliris™, Soliris™ (Alexion Pharmaceuticals)	Complement Cascade Inhibitor (Factor C5)	AMD.	188333
Efalizumab	Raptiva™, Raptiva™ (Genentech Inc)	Immunomodulatory Agents; Immunosuppressive Agents	For the treatment of adult patients with moderate to severe chronic plaque psoriasis, who are candidates for phototherapy or systemic therapy.	128771
Endostatin				
Enfuvirtide	Fuzeon™, Fuzeon™ (Roche Pharmaceuticals)	Anti-HIV Agents; HIV Fusion Inhibitors	For treatment of HIV AIDS	16768
Epoetin alfa	Epogen™ (Amgen Inc.); Epogin™ (Chugai); Epomax™ (Elanex); Eprex™ (Janssen-Cilag. Ortho	Antianemic Agents	For treatment of anemia (from renal transplants or certain HIV treatment)	55066

Table 1A. Therapeutic Agent List

Generic Name	Brands (Companies)	Category	Indication	Molecular Weight
Eptifibatid	Biologics LLC); NeoRecormon™ (Roche); Procrit™ (Ortho Biotech); Recormon™ (Roche)	Anticoagulants; Antiplatelet Agents; Platelet Aggregation Inhibitors	For treatment of myocardial infarction and acute coronary syndrome.	7128
Erlotinib	Integrilin™; Integriin™ (Millennium Pharm)	Tyrosine Kinase Inhibitors		393
Etanercept	Enbrel™; Enbrel™ (ImmuneX Corp)	Antirheumatic Agents; Immunomodulatory Agents	Uveitis, AMD	25645
Everolimus		Limus Immunophilin Binding Compounds		
Exenatide	Byetta™; Byetta™ (Amylin/Eli Lilly)		Indicated as adjunctive therapy to improve glycemic control in patients with Type 2 diabetes mellitus who are taking metformin, a sulfonylurea, or a combination of both, but have not achieved adequate glycemic control.	53060
FCFD4514S	Genentech/Roche	Complement Cascade Inhibitor (Factor D)	AMD, Geographic Atrophy	
Felypressin	Felipresina™ [INN-Spanish]; Felipressina™ [DCIT]; Felypressin™ [USAN:INN]; Felypressine™ [INN-French]; Felypressinum™ [INN-Latin]; Octapressin	Renal Agents; Vasoconstrictor Agents	For use as an alternative to adrenaline as a 143ocalizing agent, provided that local ischaemia is not essential.	46800

Table 1A. Therapeutic Agent List

Generic Name	Brands (Companies)	Category	Indication	Molecular Weight
Fenretinide	(Sirion Therapeutics)	Binding Protein Antagonist for Oral Vitamin A	AMD	
Filgrastim	Neupogen™ (Amgen Inc.)	Anti-Infective Agents; Antineutropenic Agents; Immunomodulatory Agents	Increases leukocyte production, for treatment in non-myeloid cancer, neutropenia and bone marrow transplant	28518
FK605-binding proteins, FKBP5		Limus Immunophilin Binding Compounds		
Fluocinolone Acetonide	Retisert™ (Bausch & Lomb); Iluvien™ (Allimera Sciences, Inc.)	Glucocorticoid	Retinal inflammation, diabetic macular edema	453
Follitropin beta	Follistim™ (Organon); Gonal F™; Gonal-F™	Fertility Agents	For treatment of female infertility	78296
Fumagillin				
Galsulfase	Naglazyme™; Naglazyme™ (BioMarin Pharmaceuticals)	Enzyme Replacement Agents	For the treatment of adults and children with Mucopolysaccharidosis VI.	47047
Gefitinib		Tyrosine Kinase Inhibitors		447
Gemtuzumab ozogamicin	Mylotarg™; Mylotarg™ (Wyeth)	Antineoplastic Agents	For treatment of acute myeloid leukemia	39826
Glatiramer Acetate	Copaxone™	Adjuvants, Immunologic; Immunosuppressive Agents	For reduction of the frequency of relapses in patients with Relapsing-Remitting Multiple Sclerosis.	29914

Table 1A. Therapeutic Agent List

Generic Name	Brands (Companies)	Category	Indication	Molecular Weight
Glucagon recombinant	GlucaGen <sup>TM</sup> (Novo Nordisk); Glucagon <sup>TM</sup> (Eli Lilly)	Antihypoglycemic Agents	For treatment of severe hypoglycemia, also used in gastrointestinal imaging	54009
Goserelin	Zoladex <sup>TM</sup>	Antineoplastic Agents; Antineoplastic Agents, Hormonal	Breast cancer; Prostate carcinoma; Endometriosis	78617
Human Serum Albumin	Albutein <sup>TM</sup> (Alpha Therapeutic Corp)	Serum substitutes	For treatment of severe blood loss, hypervolemia, hypoproteinemia	39000
Hyaluronidase	Vitragan <sup>TM</sup> ; Vitrase <sup>TM</sup> ; Vitrase <sup>TM</sup> (Ista Pharma)	Anesthetic Adjuvants; Permeabilizing Agents	For increase of absorption and distribution of other injected drugs and for rehydration	69367
Ibritumomab	Zevalin <sup>TM</sup> (IDEC Pharmaceuticals)	Antineoplastic Agents	For treatment of non-Hodgkin's lymphoma	33078
Idursulfase	Elaprase <sup>TM</sup> (Shire Pharmaceuticals)	Enzyme Replacement Agents	For the treatment of Hunter syndrome in adults and children ages 5 and older.	47047
Imatinib		Tyrosine Kinase Inhibitors	AMD, DME	494
Immune globulin	Civacir <sup>TM</sup> ; Fiebogamma <sup>TM</sup> (Istituto Grifols SA); Gamunex <sup>TM</sup> (Talecris Biotherapeutics)	Anti-Infectives; Immunomodulatory Agents	For treatment of immunodeficiencies, thrombocytopenic purpura, Kawasaki disease, gammablobulinemia, leukemia, bone transplant	42632
Infliximab	Remicade <sup>TM</sup> (Centocor Inc)	Immunomodulatory Agents; Immunosuppressive Agents	Uveitis, AMD	25645

Table 1A. Therapeutic Agent List

Generic Name	Brands (Companies)	Category	Indication	Molecular Weight
Insulin Glargine recombinant	Lantus™	Hypoglycemic Agents	For treatment of diabetes (type I and II)	156308
Insulin Lyspro recombinant	Humalog™ (Eli Lilly); Insulin Lispro (Eli Lilly)	Hypoglycemic Agents	For treatment of diabetes (type I and II)	154795
Insulin recombinant	Novolin R™ (Novo Nordisk)	Hypoglycemic Agents	For treatment of diabetes (type I and II)	156308
Insulin, porcine	Iletin II™	Hypoglycemic Agents	For the treatment of diabetes (type I and II)	156308
Interferon				
Interferon Alfa-2a, Recombinant	Roferon A™ (Hoffmann-La Roche Inc); Veldona™ (Amarillo Biosciences)	Antineoplastic Agents; Antiviral Agents	For treatment of chronic hepatitis C, hairy cell leukemia, AIDS-related Kaposi's sarcoma, and chronic myelogenous leukemia. Also for the treatment of oral warts arising from HIV infection.	57759
Interferon Alfa-2b, Recombinant	Intron A™ (Schering Corp)	Antineoplastic Agents; Antiviral Agents; Immunomodulatory Agents	For the treatment of hairy cell leukemia, malignant melanoma, and AIDS-related Kaposi's sarcoma.	57759
Interferon alfacon-1	Advaferon™; Infergen™ (InterMune Inc)	Antineoplastic Agents; Antiviral Agents; Immunomodulatory Agents	For treatment of hairy cell leukemia, malignant melanoma, and AIDS-related Kaposi's sarcoma	57759
Interferon alfa-n1	Wellferon™ (GlaxoSmithKline)	Antiviral Agents; Immunomodulatory Agents	For treatment of venereal or genital warts caused by the Human Papilloma Virus	57759

Table 1A. Therapeutic Agent List

Generic Name	Brands (Companies)	Category	Indication	Molecular Weight
Interferon alfa-n3	Alferon™ (Interferon Sciences Inc.); Alferon LDO™; Alferon N Injection™	Antineoplastic Agents; Antiviral Agents; Immunomodulatory Agents	For the intralesional treatment of refractory or recurring external condylomata 147cuminata.	57759
Interferon beta-1b	Betaseron™ (Chiron Corp)	Antiviral Agents; Immunomodulatory Agents	For treatment of relapsing/remitting multiple sclerosis	57759
Interferon gamma-1b	Actimmune™; Actimmune™ (InterMune Inc)	Antiviral Agents; Immunomodulatory Agents	For treatment of Chronic granulomatous disease, Osteopetrosis	37835
Lapatinib		Tyrosine Kinase Inhibitors		581
Lepirudin	Refludan™	Anticoagulants; Antithrombotic Agents; Fibrinolytic Agents	For the treatment of heparin-induced thrombocytopenia	70037
Lestaurtinib		Tyrosine Kinase Inhibitors		439
Leuprolide	Eligard™ (Atrix Labs/QLT Inc)	Anti-Estrogen Agents; Antineoplastic Agents	For treatment of prostate cancer, endometriosis, uterine fibroids and premature puberty	37731
Lutropin alfa	Luveris™ (Serono)	Fertility Agents	For treatment of female infertility	78617
Mecasermin	Increlex™; Increlex™ (Tercica); Iplex		For the long-term treatment of growth failure in pediatric patients with Primary IGFD or with GH gene deletion who have developed neutralizing antibodies to GH. It is not indicated to treat Secondary IGFD resulting from GH deficiency, malnutrition, hypoth	154795

Table 1A. Therapeutic Agent List

Generic Name	Brands (Companies)	Category	Indication	Molecular Weight
Menotropins	Repronex™	Fertility Agents	For treatment of female infertility	78617
Methotrexate		Immunomodulatory	Uveitis, DME	
mTOR inhibitors				
Muromonab	Orthoclone OKT3™ (Ortho Biotech)	Immunomodulatory Agents; Immunosuppressive Agents	For treatment of organ transplant recipients, prevention of organ rejection	23148
Natalizumab	Tysabri™	Immunomodulatory Agents	For treatment of multiple sclerosis.	115334
Nepafenac		Cyclooxygenase Inhibitors		
Nesiritide	Natrecor™	Cardiac drugs	For the intravenous treatment of patients with acutely decompensated congestive heart failure who have dyspnea at rest or with minimal activity.	118921
Nilotinib		Tyrosine Kinase Inhibitors		530
NS398		Cyclooxygenase Inhibitors		



Table 1A. Therapeutic Agent List

Generic Name	Brands (Companies)	Category	Indication	Molecular Weight
Octreotide	Atrigel <sup>TM</sup> ; Longastatin <sup>TM</sup> ; Sandostat <sup>TM</sup> ; Sandostat LAR <sup>TM</sup> ; Sandostat LAR <sup>TM</sup> (Novartis)	Anabolic Agents; Antineoplastic Agents, Hormonal; Gastrointestinal Agents; Hormone Replacement Agents	For treatment of acromegaly and reduction of side effects from cancer chemotherapy	42687
Omalizumab	Xolair <sup>TM</sup> (Genentech Inc)	Anti-Asthmatic Agents; Immunomodulatory Agents	For treatment of asthma caused by allergies	29596
Oprelvekin	Neumega <sup>TM</sup> ; Neumega <sup>TM</sup> (Genetics Institute Inc)	Coagulants; Thrombotics	Increases reduced platelet levels due to chemotherapy	45223
OspA lipoprotein	LYMERix <sup>TM</sup> (SmithKline Beecham)	Vaccines	For prophylactic treatment of Lyme Disease	95348
OT-551	(Othera)	Anti-oxidant eyedrop	AMD	
Oxytocin	Oxytocin <sup>TM</sup> (BAM Biotech); Pitocin <sup>TM</sup> (Parke-Davis); Syntocinon <sup>TM</sup> (Sandoz)	Anti-tocolytic Agents; Labor Induction Agents; Oxytocics	To assist in labor, elective labor induction, uterine contraction induction	12722
Palifermin	Kepivance <sup>TM</sup> (Amgen Inc)	Antimucositis Agents	For treatment of mucositis (mouth sores)	138885
Palivizumab	Synagis <sup>TM</sup>	Antiviral Agents	For treatment of respiratory diseases caused by respiratory syncytial virus	63689
Panitumumab	Vectibix <sup>TM</sup> ; Vectibix <sup>TM</sup> (Amgen)	Antineoplastic Agents	For the treatment of EGFR-expressing, metastatic colorectal carcinoma with disease progression on or following fluoropyrimidine-, oxaliplatin-, and irinotecan- containing chemotherapy regimens.	134279

Table 1A. Therapeutic Agent List

Generic Name	Brands (Companies)	Category	Indication	Molecular Weight
PDGF inhibitor	(Jerini Ophthalmic); (Ophthotech)	Inhibitors of PDGF	AMD	
PEDF (pigment epithelium derived factor)				
Pegademase bovine	Adagen™ (Enzon Inc.)	Enzyme Replacement Agents	For treatment of adenosine deaminase deficiency	36512
Pegaptanib	Macugen™	Oligonucleotide	For the treatment of neovascular (wet) age-related macular degeneration.	103121
Pegaspargase	Oncaspar™ (Enzon Inc)	Antineoplastic Agents	For treatment of acute lymphoblastic leukemia	132.118
Pegfilgrastim	Neulasta™ (Amgen Inc.)	Anti-Infective Agents; Antineutropenic Agents; Immunomodulatory Agents	Increases leukocyte production, for treatment in non-myeloid cancer, neutropenia and bone marrow transplant	28518
Peginterferon alfa-2a	Pegasys™ (Hoffman-La Roche Inc)	Antineoplastic Agents; Antiviral Agents; Immunomodulatory Agents	For treatment of hairy cell leukemia, malignant melanoma, and AIDS-related Kaposi's sarcoma.	57759
Peginterferon alfa-2b	PEG-Intron (Schering Corp); Unitron PEG™	Antineoplastic Agents; Antiviral Agents; Immunomodulatory Agents	For the treatment of chronic hepatitis C in patients not previously treated with interferon alpha who have compensated liver disease and are at least 18 years of age.	57759
Pegvisomant	Somavert™ (Pfizer Inc)	Anabolic Agents; Hormone Replacement Agents	For treatment of acromegaly	71500

Table 1A. Therapeutic Agent List

Generic Name	Brands (Companies)	Category	Indication	Molecular Weight
Pentoxifylline				
Perindozril		ACE Inhibitors		
Pimecrolimus		Limus Immunophilin Binding Compounds		
PKC (protein kinase C) inhibitors				
POT-4	Potentia/Alcon	Complement Cascade Inhibitor (Factor C3)	AMD	
Pramlintide	Symlin™; Symlin™ (Amylin Pharmaceuticals)		For the mealtime treatment of Type I and Type II diabetes in combination with standard insulin therapy, in patients who have failed to achieve adequate glucose control on insulin monotherapy.	16988
Proteasome inhibitors	Velcade™		Proteasome inhibitors	
Pyrrolidine				
Quinopril		ACE Inhibitors		

Table 1A. Therapeutic Agent List

Generic Name	Brands (Companies)	Category	Indication	Molecular Weight
Ranibizumab	Lucentis™		For the treatment of patients with neovascular (wet) age-related macular degeneration.	27043
Rapamycin (sirolimus)	(MacuSight)	Limus Immunophilin Binding Compounds	AMD	
Rasburicase	Elitek™, Elitek™ (Sanofi-Synthelabo Inc); Fasturtec™	Antihyperuricemic Agents	For treatment of hyperuricemia, reduces elevated plasma uric acid levels (from chemotherapy)	168.11
Retepase	Retavase™ (Centocor); Retavase™ (Roche)	Thrombolytic Agents	For lysis of acute pulmonary emboli, intracoronary emboli and management of myocardial infarction	54732
Retinal stimulant	Neurosolve™ (Vitreoretinal Technologies)	Retinal stimulants	AMD	
Retinoid(s)				
Rituximab	MabThera™; Rituxan™	Antineoplastic Agents	For treatment of B-cell non-Hodgkins lymphoma (CD20 positive)	33078
RNAI (RNA interference of angiogenic factors)				
Rofecoxib	Vioxx™; Ceoxx™; Ceeoxx™ (Merck & Co.)	Cyclooxygenase Inhibitors		
Rosiglitazone		Thiazolidinediones		

Table 1A. Therapeutic Agent List

Generic Name	Brands (Companies)	Category	Indication	Molecular Weight
Ruboxistaurin	Eli Lilly	Protein Kinase C (PKC)-b Inhibitor	DME, diabetic peripheral retinopathy	469
Salmon Calcitonin	Calcimar™; Miacalcin™ (Novartis)	Antihypocalcemic Agents; Antiestrogenic Agents; Bone Density Conservation Agents	For the treatment of post-menopausal osteoporosis	57304
SAR 1118	SARCode	Immunomodulatory Agent	Dry eye, DME, conjunctivitis	
Sargramostim	Immunex™; Leucimax™ (Novartis); Leukine™; Leukine™ (Berlex Laboratories Inc)	Anti-Infective Agents; Antineoplastic Agents; Immunomodulatory Agents	For the treatment of cancer and bone marrow transplant	46207
SDZ-RAD		Limus Immunophiliin Binding Compounds		
Secretin	SecreFlo™, Secremax™, SecreFlo™ (Repligen Corp)	Diagnostic Agents	For diagnosis of pancreatic exocrine dysfunction and gastrinoma	50207
Selective inhibitor of the factor 3 complement cascade				
Selective inhibitor of the factor 5 complement cascade				
Semaxanib		Tyrosine Kinase Inhibitors		238

Table 1A. Therapeutic Agent List

Generic Name	Brands (Companies)	Category	Indication	Molecular Weight
Sermorelin	Geref™ (Serono Pharma)	Anabolic Agents; Hormone Replacement Agents	For the treatment of dwarfism, prevention of HIV-induced weight loss	47402
Serum albumin iodinated	Megatope™ (IsoTex Diagnostics)	Imaging Agents	For determination of total blood and plasma volumes	39000
SF1126	Semafore	PI3K/mTOR Inhibition	AMD, DME	
Sirolimus reformulation (rapamycin)	(MacuSight)	Limus Immunophilin Binding Compounds	AMD	
siRNA molecule synthetic, FTP-801i-14	(Quark Pharmaceuticals)	siRNAi molecule synthetic	AMD	
Somatropin recombinant	BioTropin™ (Biotech General); Genotropin™ (Pfizer); Humatrope™ (Eli Lilly); Norditropin™ (Novo Nordisk); Nutropin™ (Genentech Inc.); NutropinAQ™ (Genentech Inc.); Protropin™ (Genentech Inc.); Saizen™ (Serono SA); Serostim™; Serostim™ (Serono SA); Tev-Tropin™ (GATE)	Anabolic Agents; Hormone Replacement Agents	For treatment of dwarfism, acromegaly and prevention of HIV-induced weight loss	71500
Squalamine				
Streptokinase	Streptase™ (Aventis Behringer GmbH)	Thrombolytic Agents	For the treatment of acute evolving transmural myocardial infarction, pulmonary embolism, deep vein thrombosis, arterial thrombosis or embolism and occlusion of arteriovenous	90569

Table 1A. Therapeutic Agent List

Generic Name	Brands (Companies)	Category	Indication	Molecular Weight
Sunitinib		Tyrosine Kinase Inhibitors	cannulae	398
TA106	Taligen	Complement Cascade Inhibitor (Factor B)	AMD	
Tacrolimus		Limus Immunophilin Binding Compounds		
Tenecteplase	TNKase™ (Genentech Inc)	Thrombolytic Agents	For treatment of myocardial infarction and lysis of intracoronary emboli	54732
Teriparatide	Aphela™, Forsteo™, Forteo™, Fortessa™, Ophtha™, Optia™, Optiah™, Zalectra™, Zelletra™	Bone Density Conservation Agents	For the treatment of osteoporosis in men and postmenopausal women who are at high risk for having a fracture. Also used to increase bone mass in men with primary or hypogonadal osteoporosis who are at high risk for fracture.	66361
Tetrathiomolybdate				
Thalidomide	Celgene	Anti-inflammatory, Anti-proliferative	Uveitis	
Thyrotropin Alfa	Thyrogen™ (Genzyme Inc)	Diagnostic Agents	For detection of residual or recurrent thyroid cancer	86831

Table 1A. Therapeutic Agent List

Generic Name	Brands (Companies)	Category	Indication	Molecular Weight
Tie-1 and Tie-2 kinase inhibitors				
Toceranib		Tyrosine Kinase Inhibitors		396
Tositumomab	Bexxar™ (Corixa Corp)	Antineoplastic Agents	For treatment of non-Hodgkin's lymphoma (CD20 positive, follicular)	33078
TPN 470 analogue				
Trastuzumab	Herceptin™ (Genentech)	Antineoplastic Agents	For treatment of HER2-positive pulmonary breast cancer	137912
Triamcinolone acetoneide	Triescence™	Glucocorticoid	DME, For treatment of inflammation of the retina	435
Trogililtazone		Thiazolidinediones		
Tumistatin				
Urofollitropin	Fertinex™ (Serono S.A.)	Fertility Agents	For treatment of female infertility	78296
Urokinase	Abbokinase™, Abbokinase™ (Abbott Laboratories)	Thrombolytic Agents	For the treatment of 156ulmonary embolism, coronary artery thrombosis and IV catheter clearance	90569



Table 1A. Therapeutic Agent List

Generic Name	Brands (Companies)	Category	Indication	Molecular Weight
Vandetanib		Tyrosine Kinase Inhibitors		475
Vasopressin	Pitressin™; Pressyn™	Antidiuretics; Oxytocics; Vasoconstrictor Agents	For the treatment of enuresis, polyuria, diabetes insipidus, polydipsia and oesophageal varices with bleeding	46800
Vatalanib		Tyrosine Kinase Inhibitors		347
VEGF receptor kinase inhibitor				
VEGF Trap	Aflibercept™ (Regneron Pharmaceuticals, Bayer HealthCare AG)	Genetically Engineered Antibodies	DME, cancer, retinal vein occlusion, choroidal neovascularization, delay wound healing, cancer treatment	96600
Visual Cycle Modulator ACU-4229	(Acucela)	Visual Cycle Modulator	AMD	
Vitamin(s)				
Vitronectin receptor antagonists				
Volociximab	Ophthotech	alpha5beta1 Integrin Inhibitor	AMD	
XL765	Exelixis/Sanofi-Aventis	PI3k/mTOR Inhibition	AMD, DME	

1/56

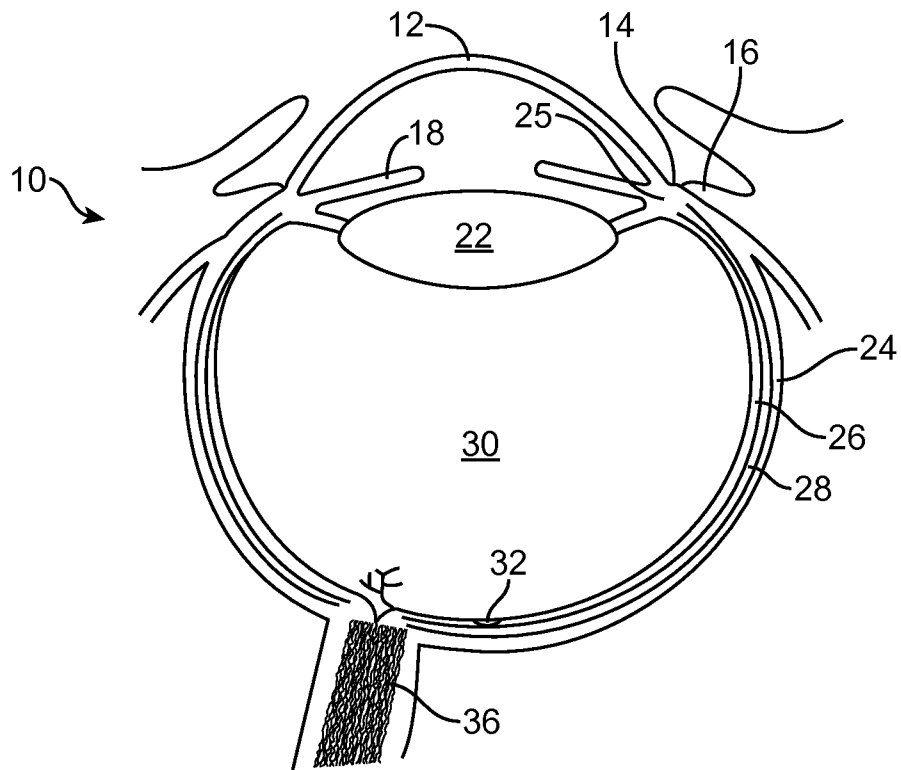

FIG. 1

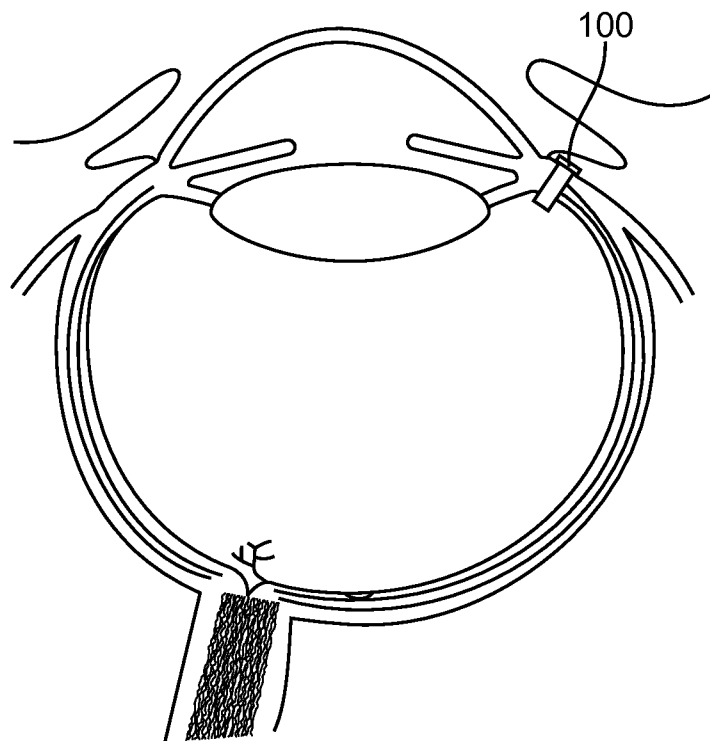

FIG. 1A-1

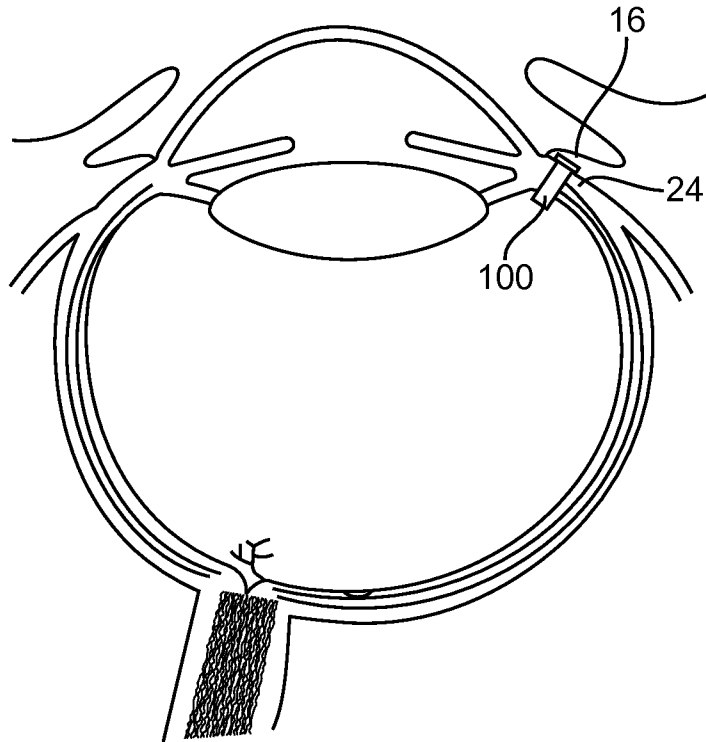

FIG. 1A-1-1

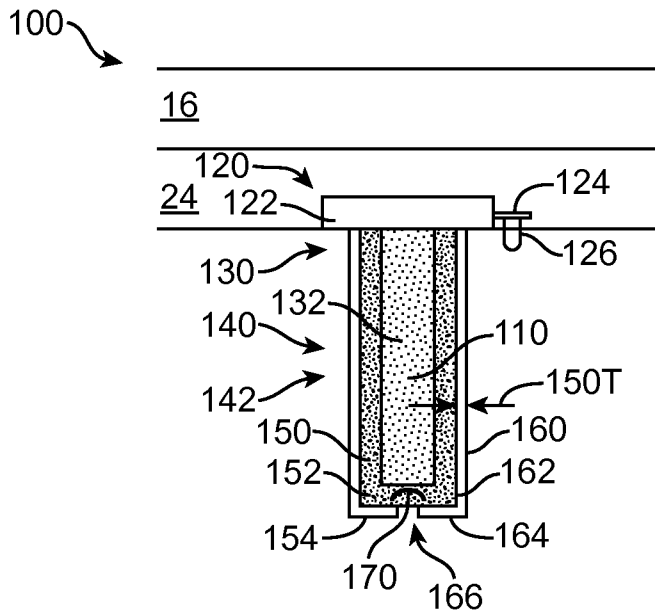

FIG. 1A-2

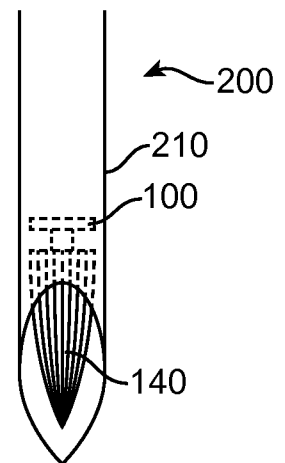

FIG. 1A-2-1

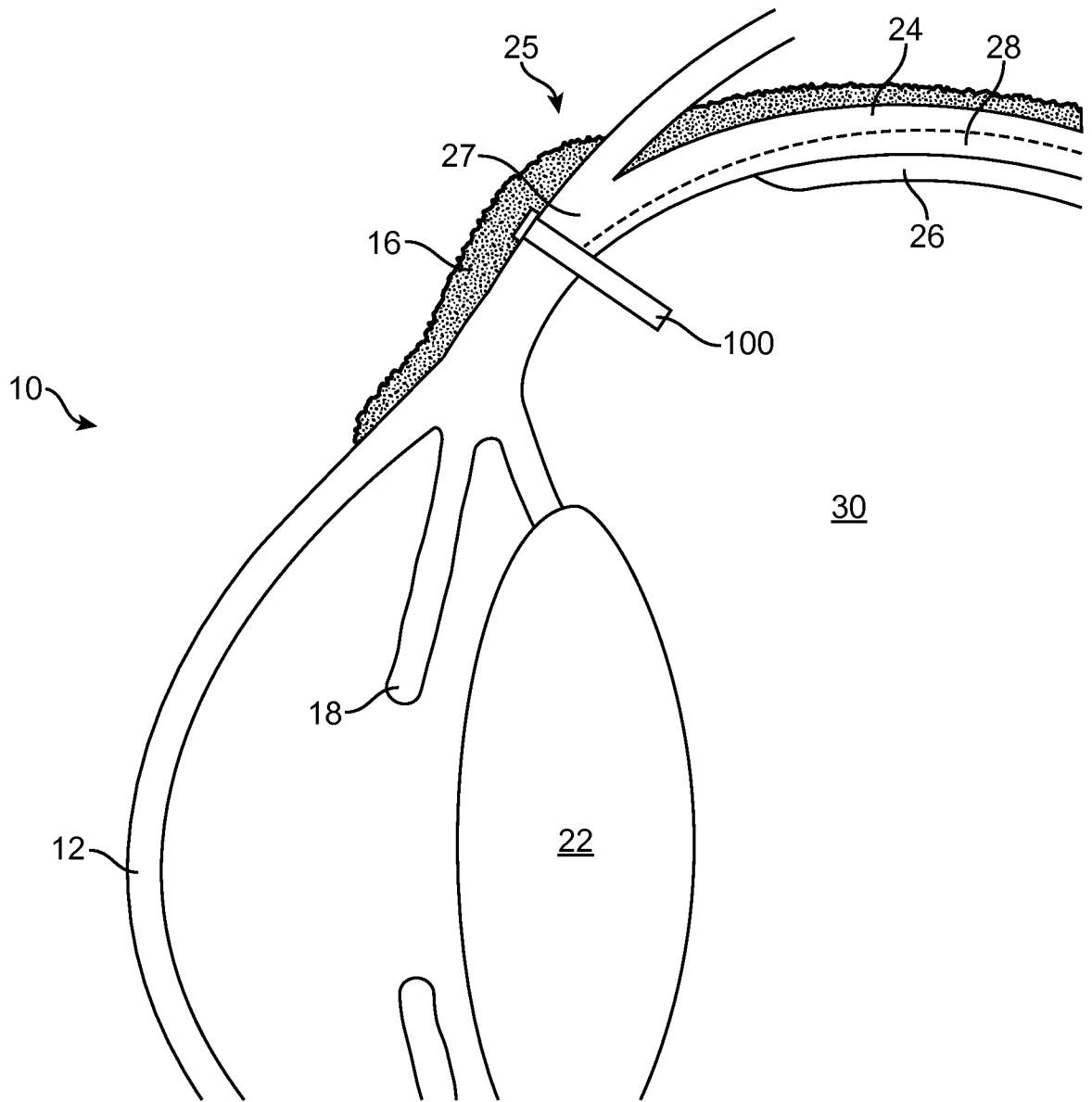

FIG. 1A-1-2

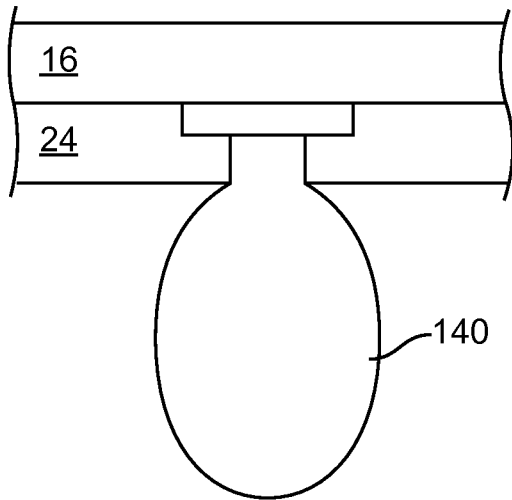

FIG. 1A-2-2

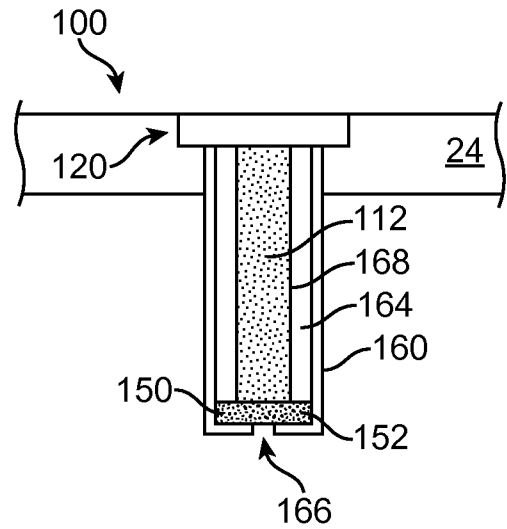

FIG. 1B

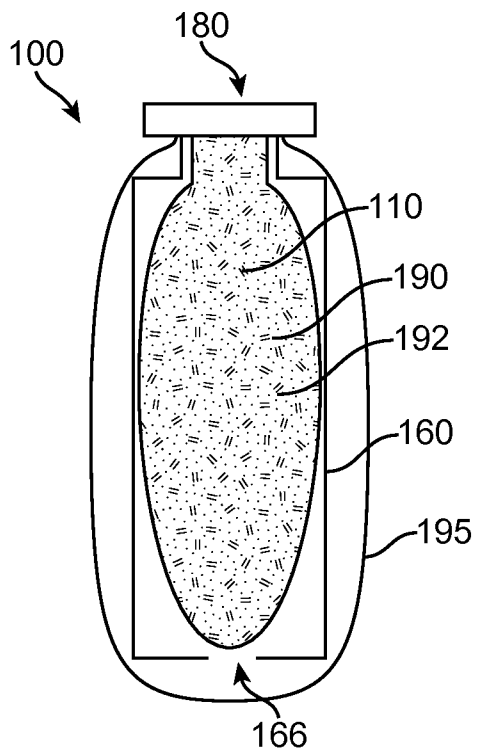

FIG. 1C

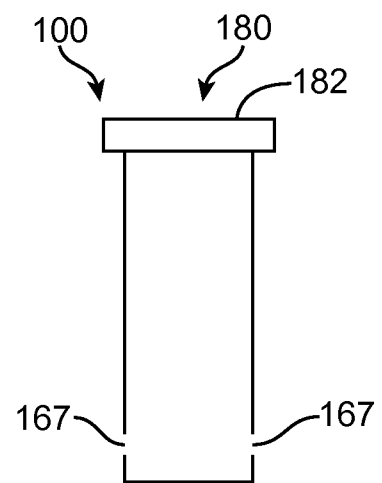

FIG. 1C-A

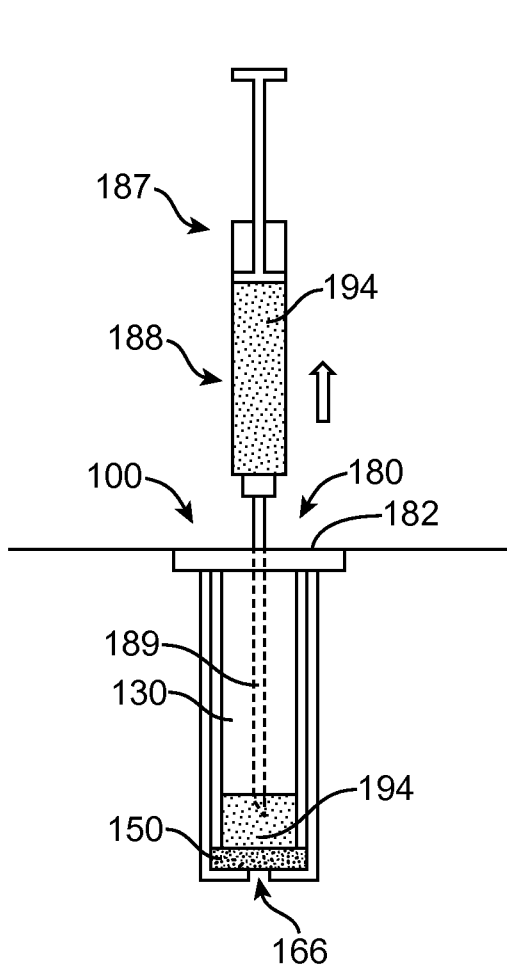

FIG. 1C-1

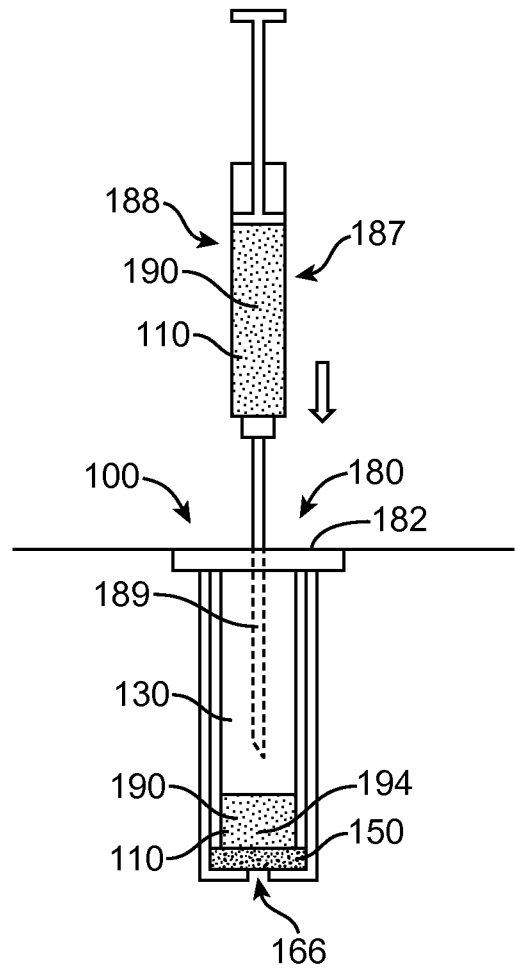

FIG. 1C-2

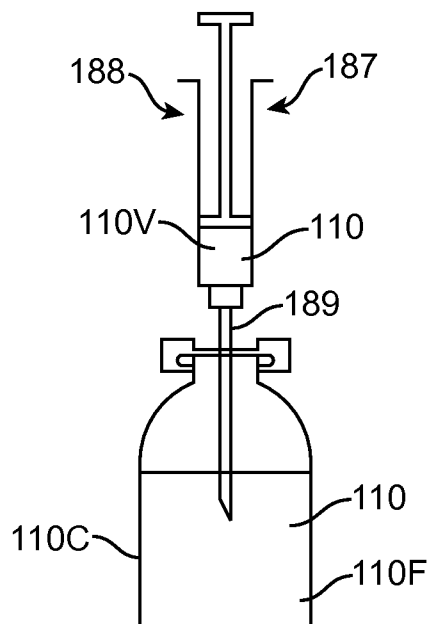

FIG. 1C-3

6/56

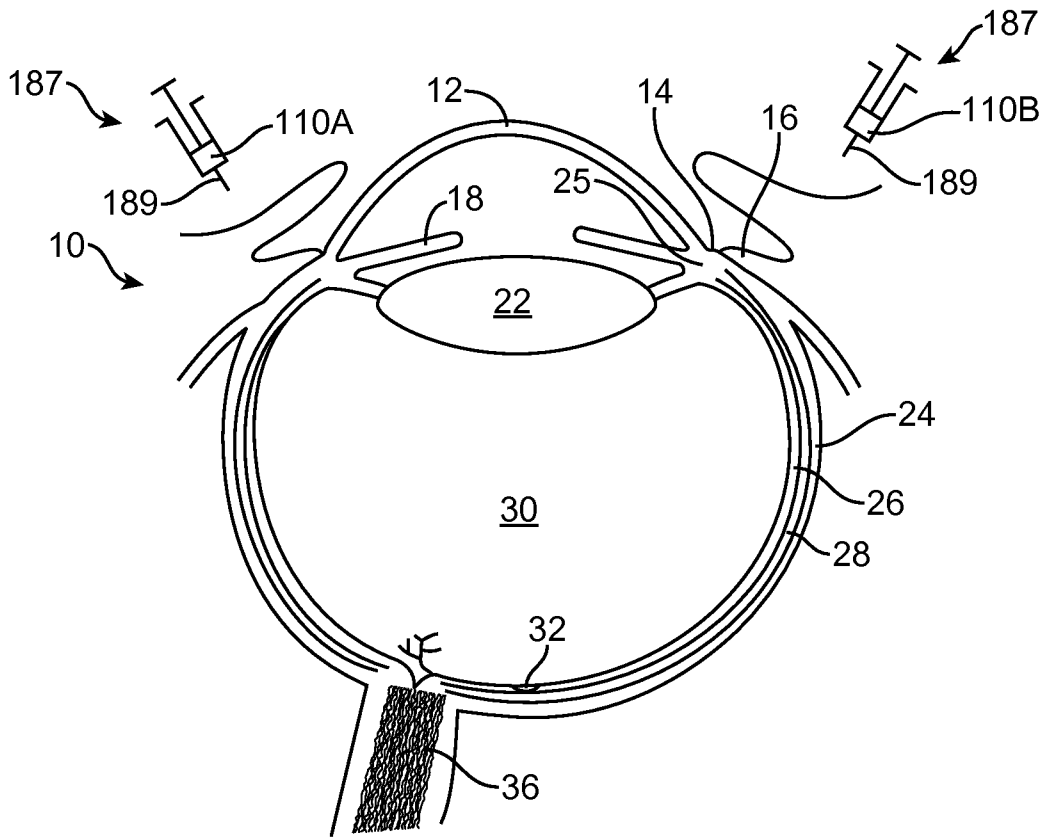

FIG. 2

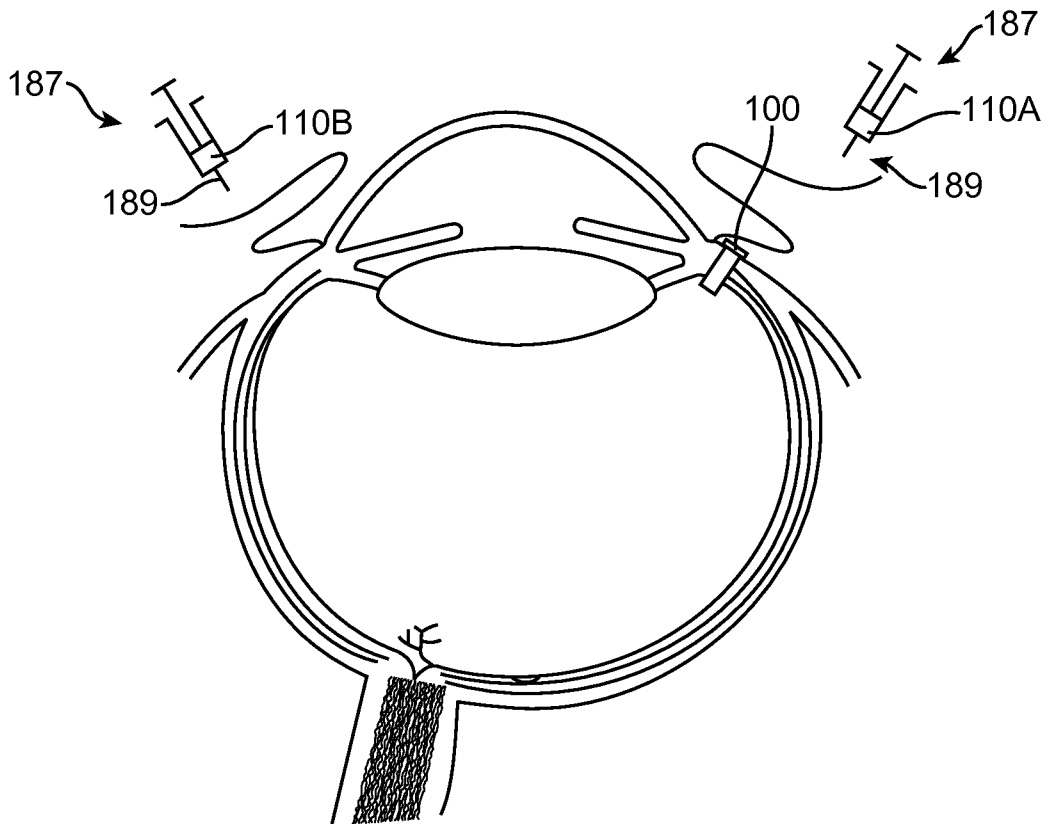

FIG. 3

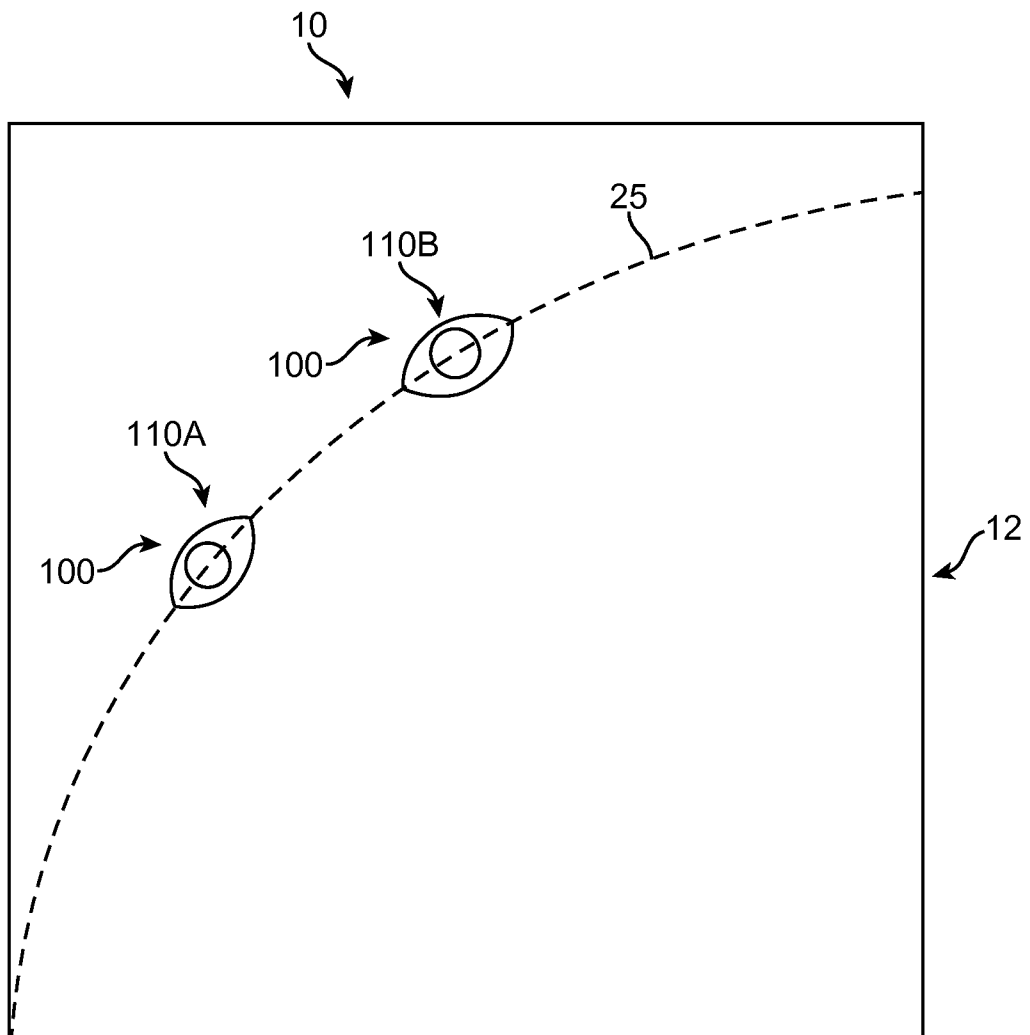

FIG. 4



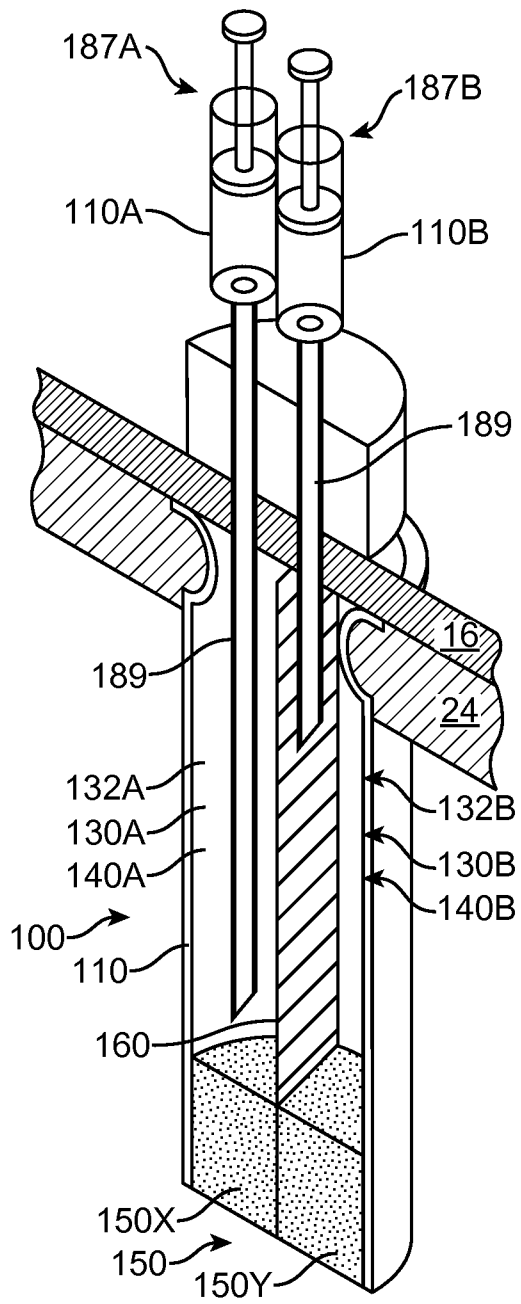

FIG. 5

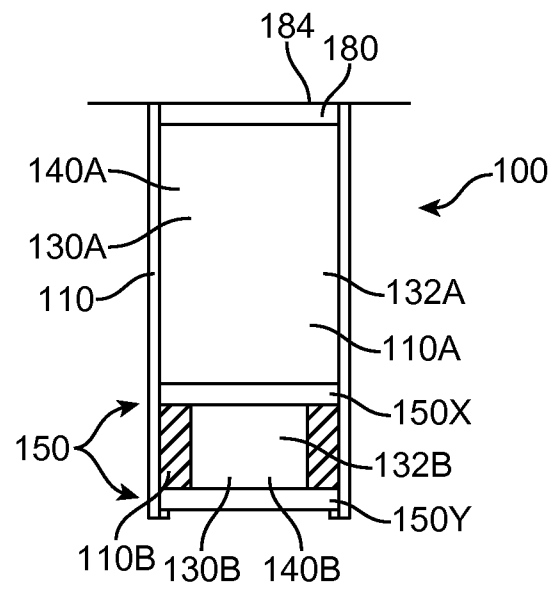

FIG. 6A

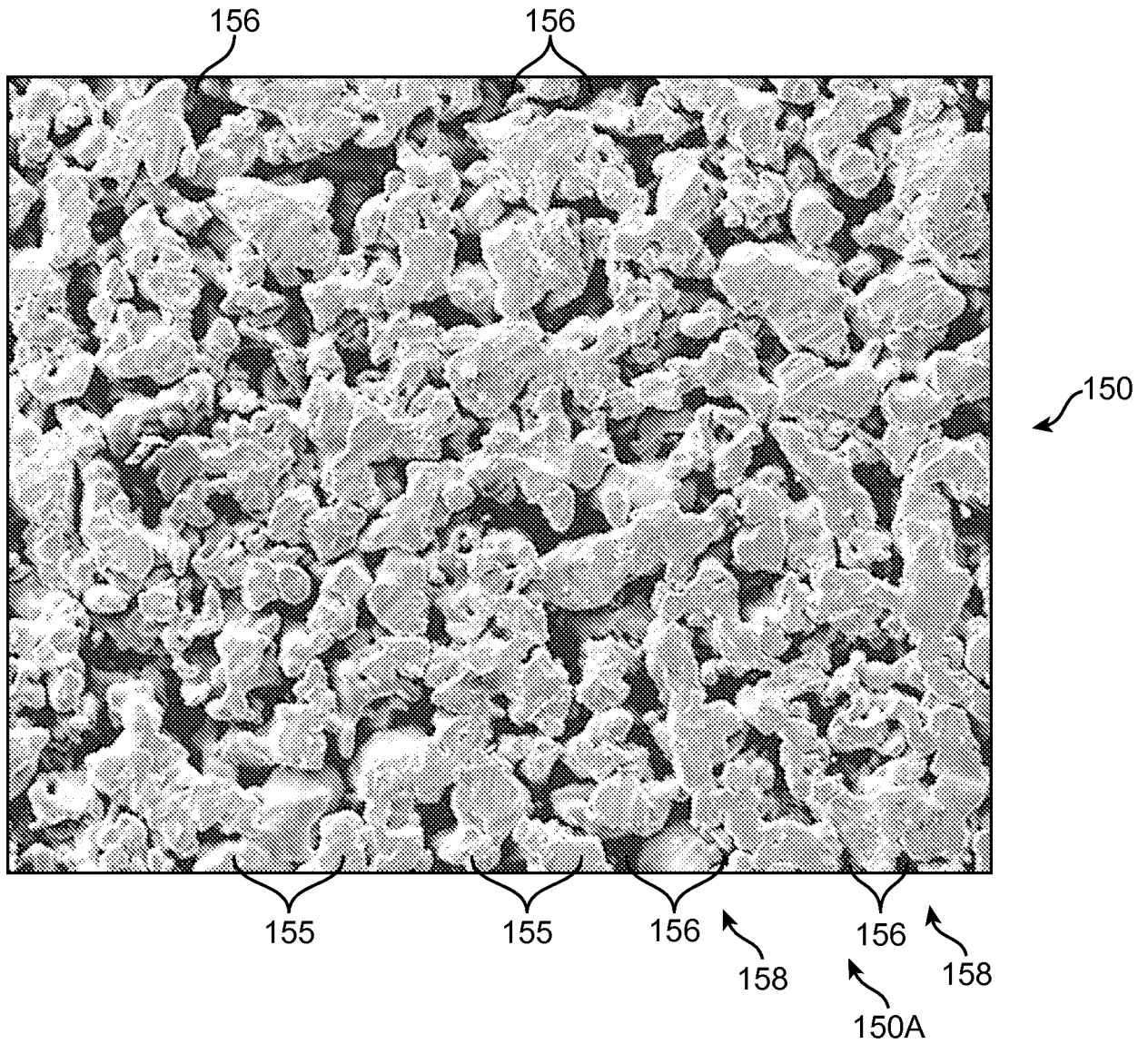

FIG. 6B

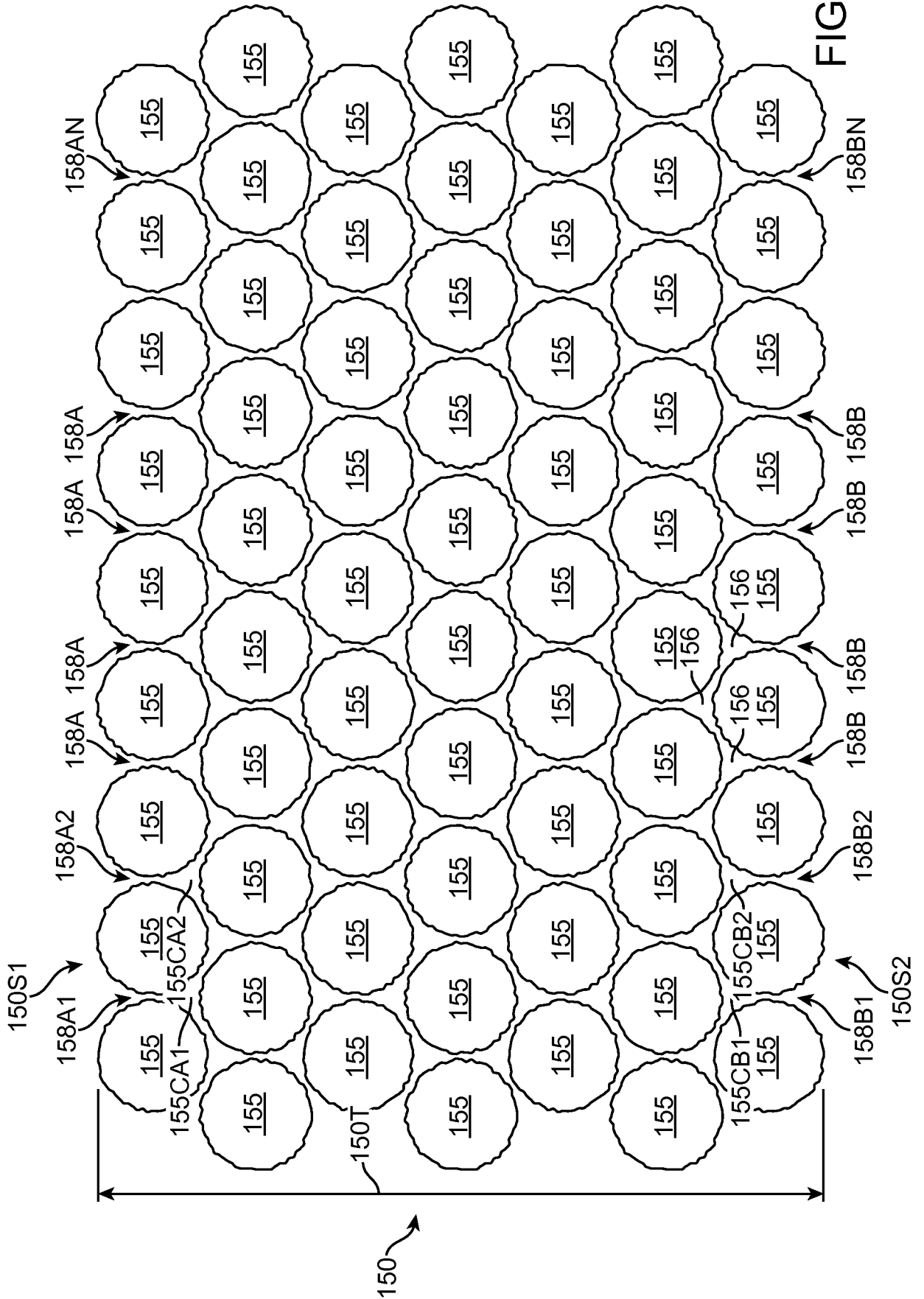

FIG. 6B-1



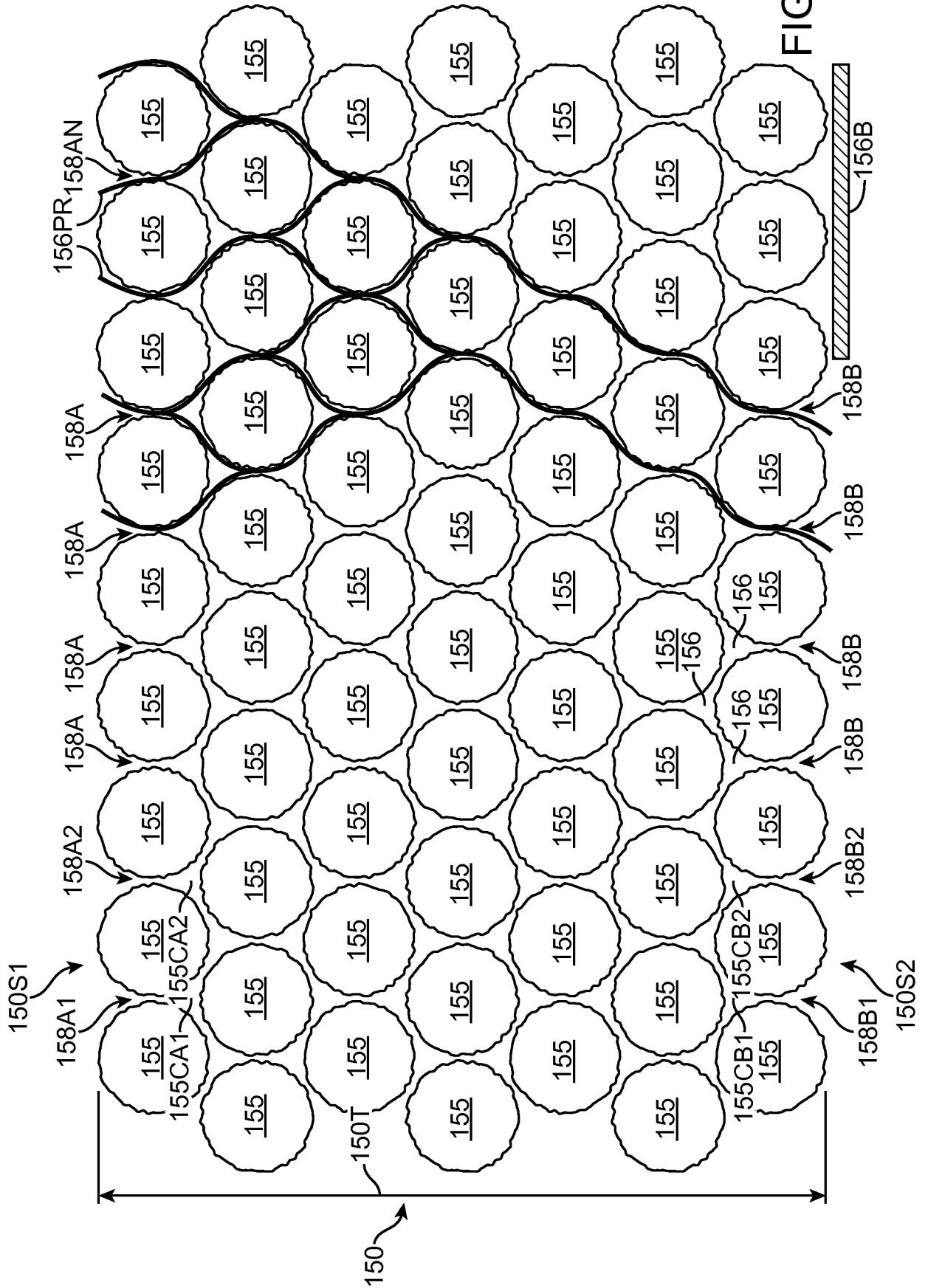

FIG. 6B-3





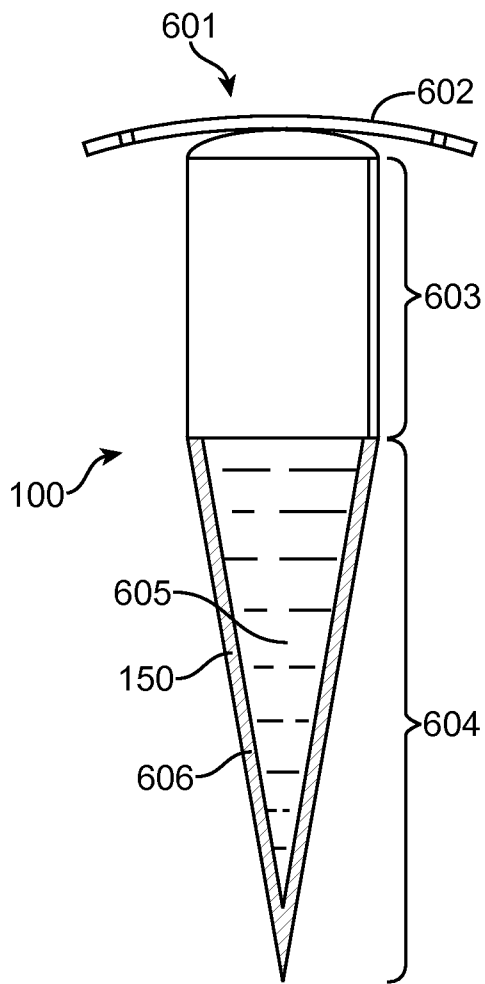

FIG. 6C

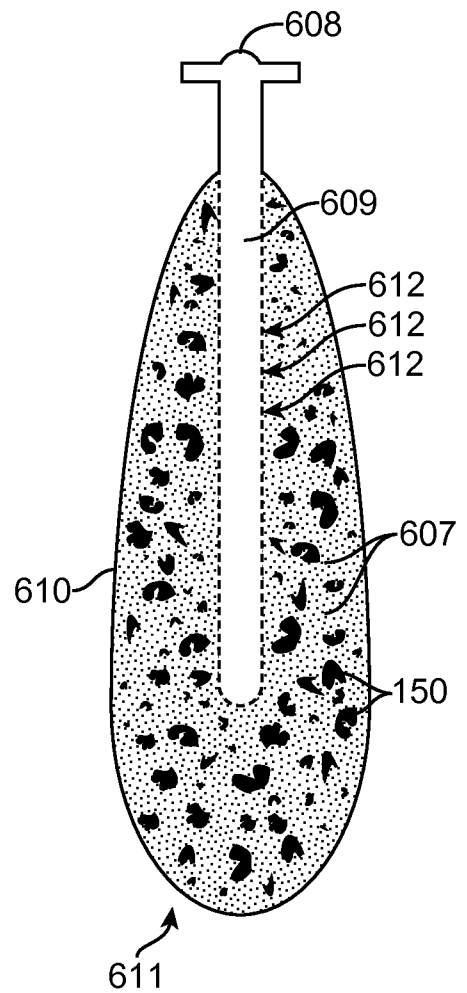

FIG. 6D

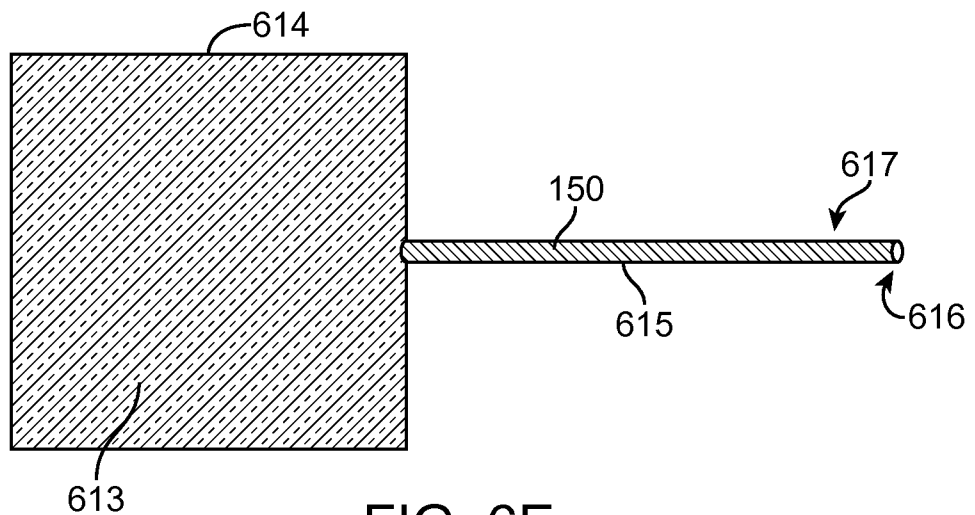

FIG. 6E





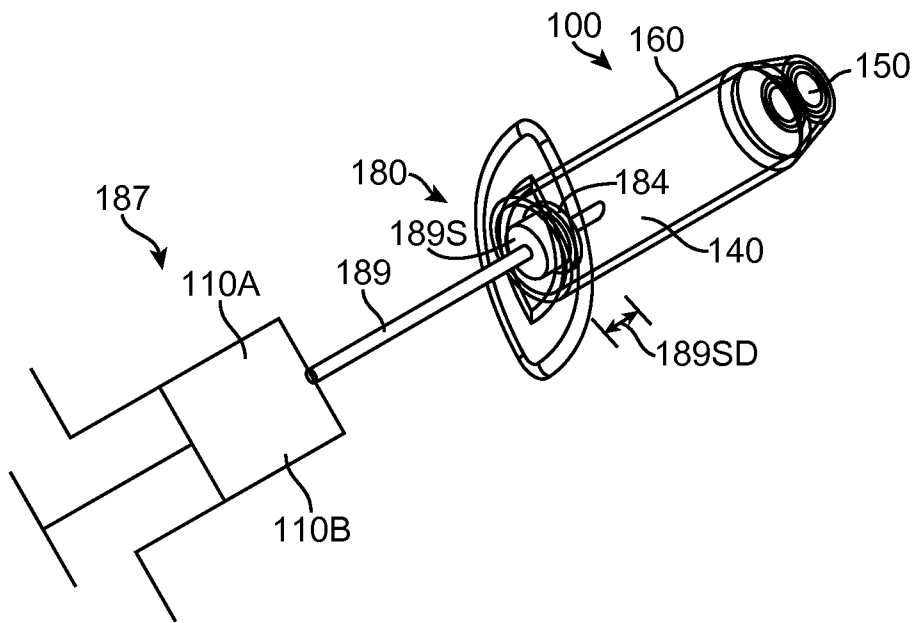

FIG. 7A

18/56

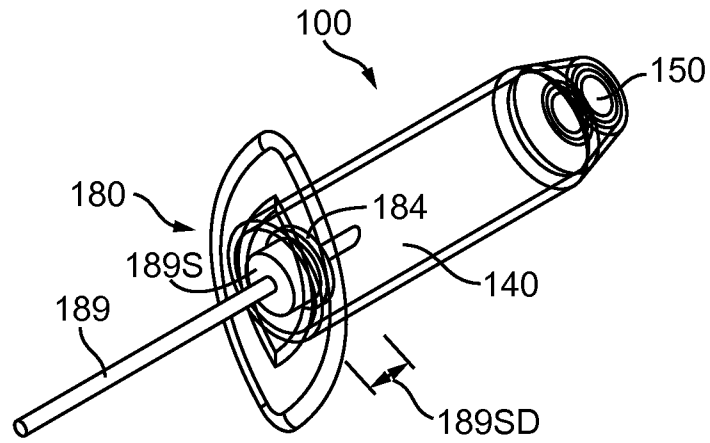

FIG. 7A-1

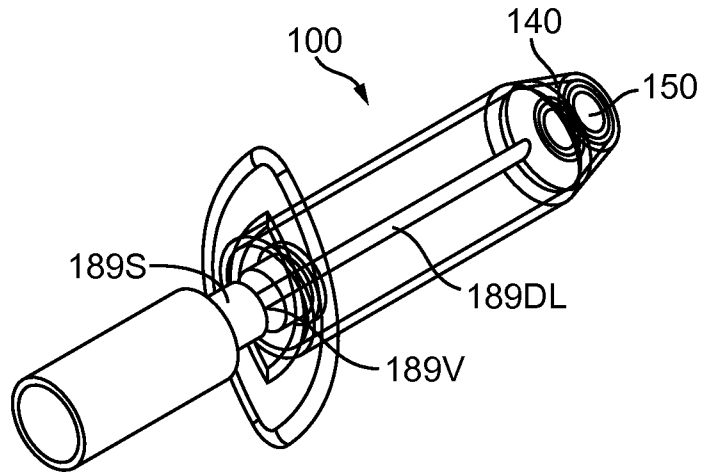

FIG. 7A-2

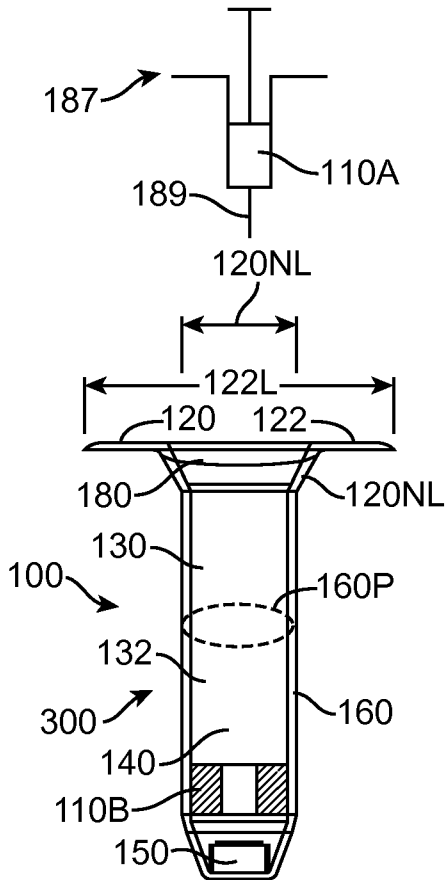

FIG. 7B-1

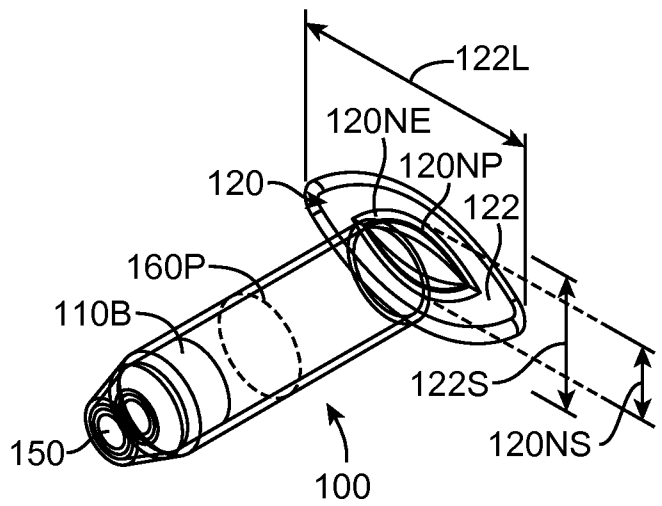

FIG. 7B-2

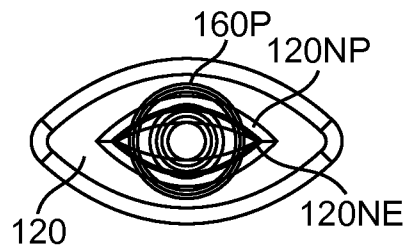

FIG. 7B-3

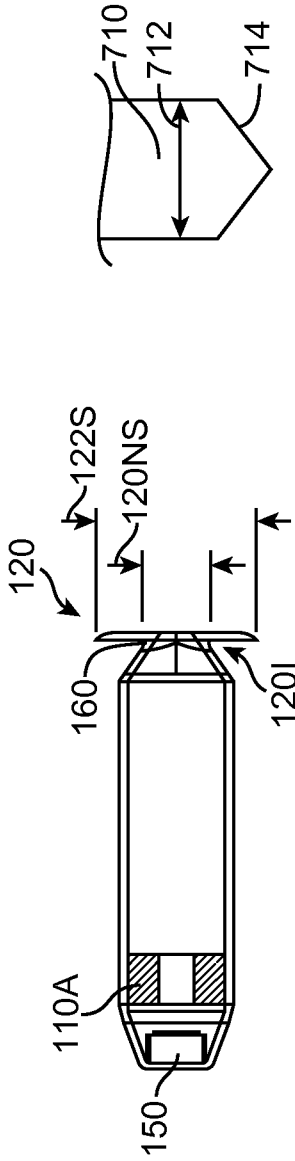

FIG. 7B-5A

FIG. 7B-4

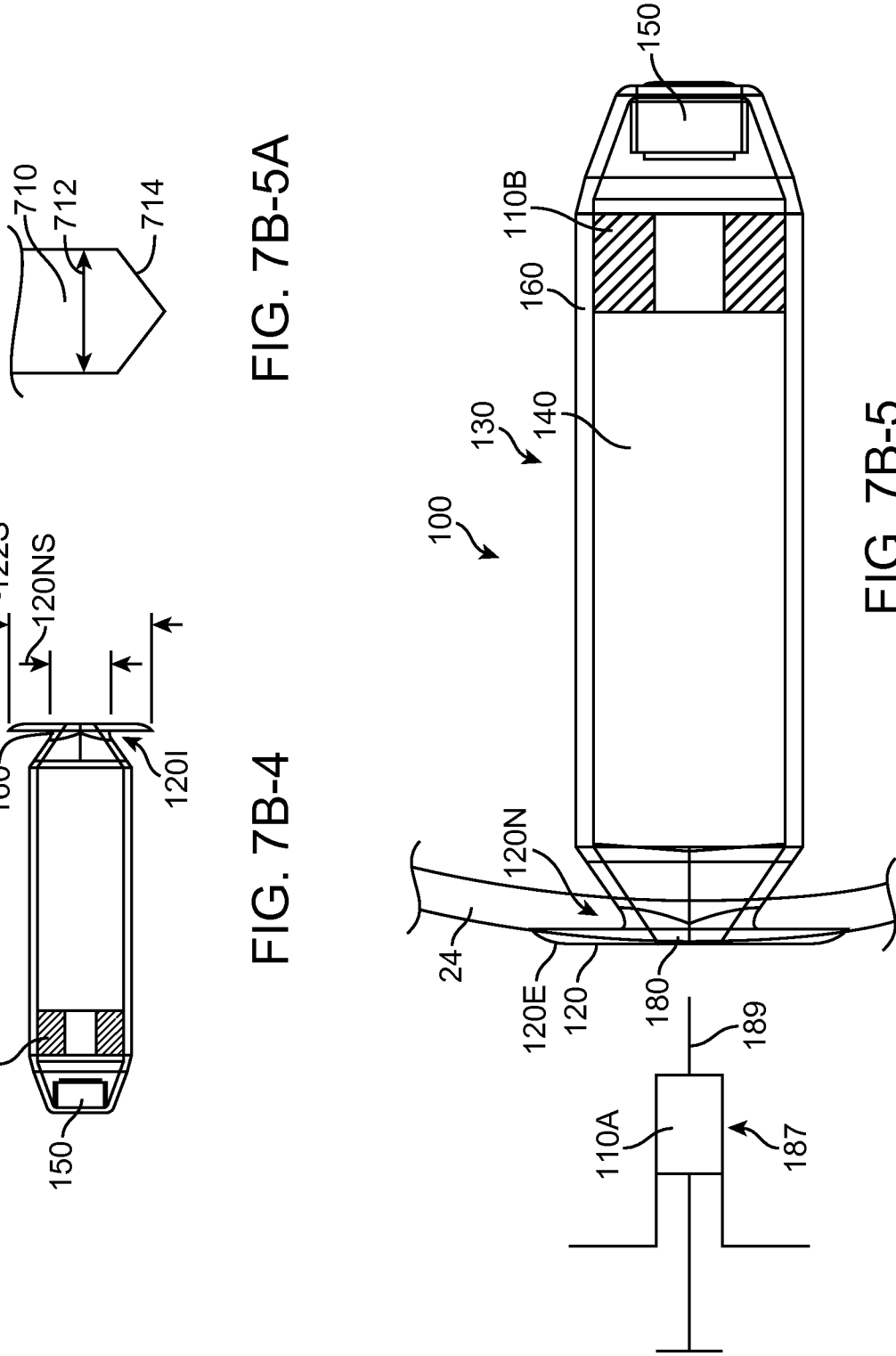

FIG. 7B-5

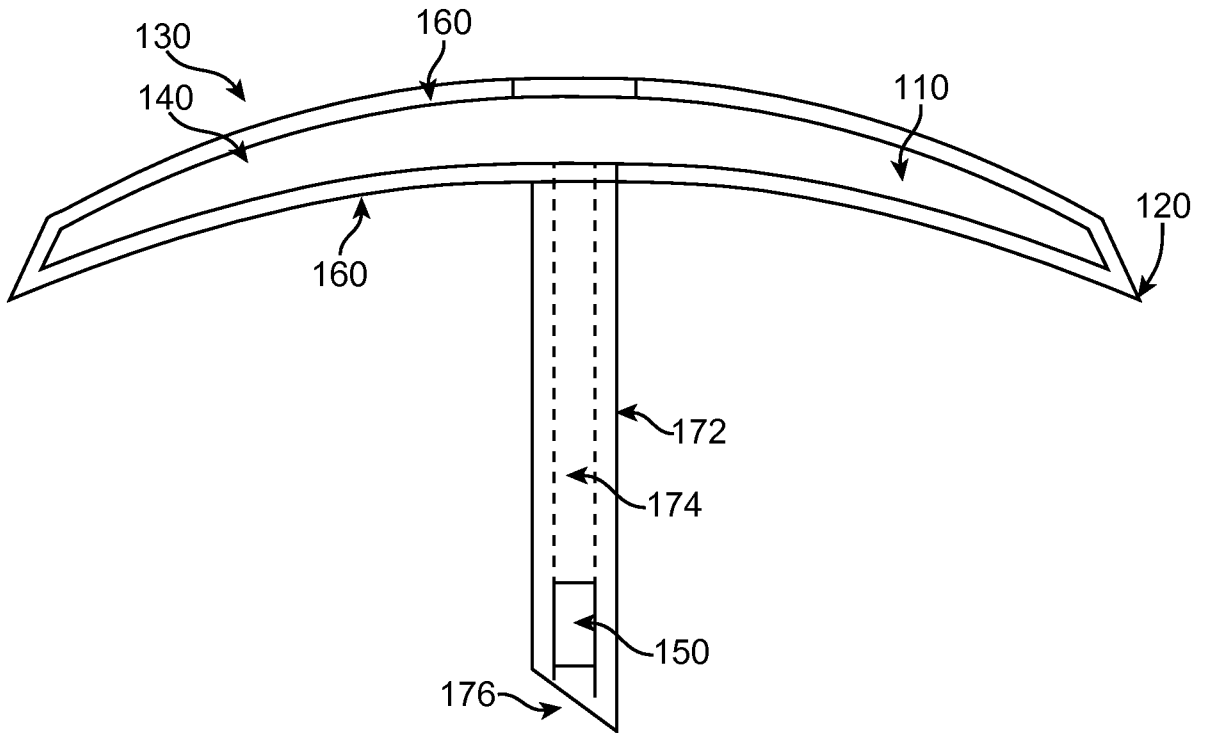

FIG. 8A

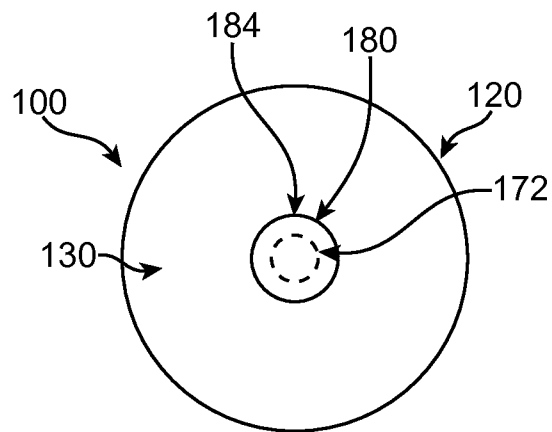

FIG. 8A1



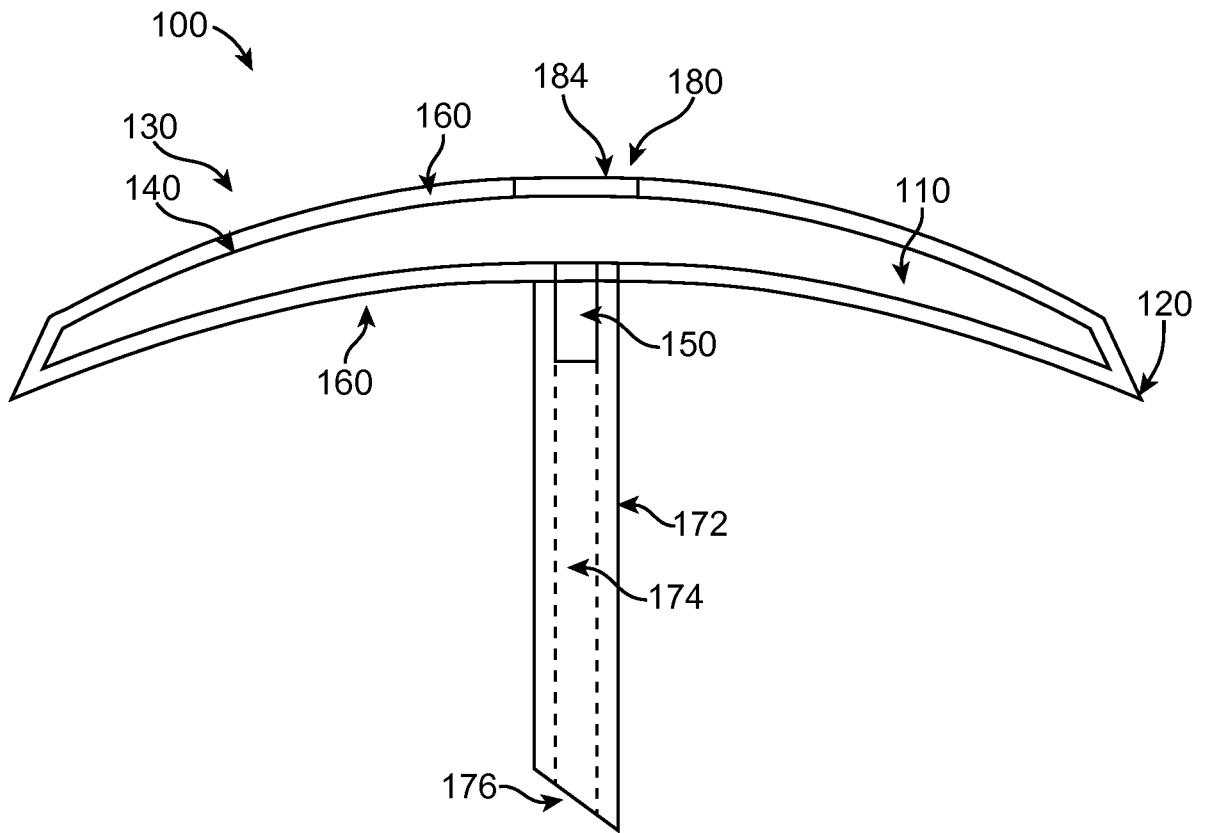

FIG. 9



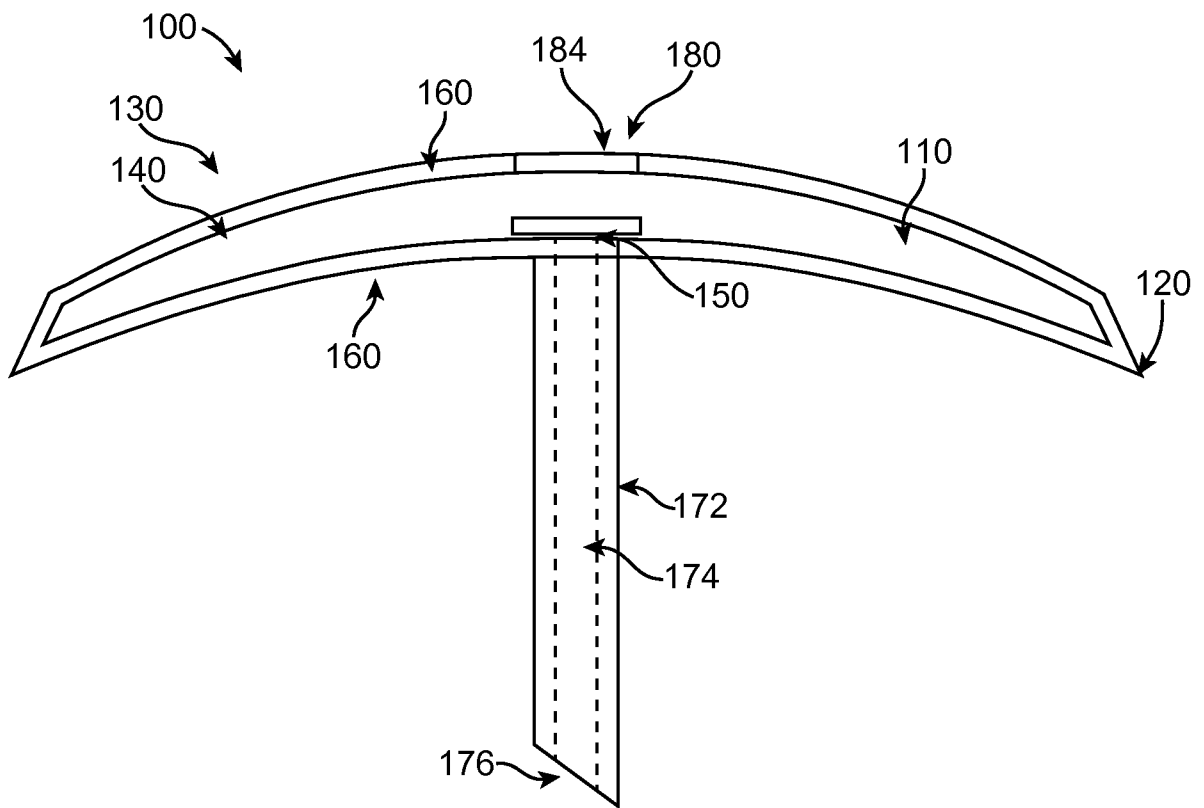

FIG. 10



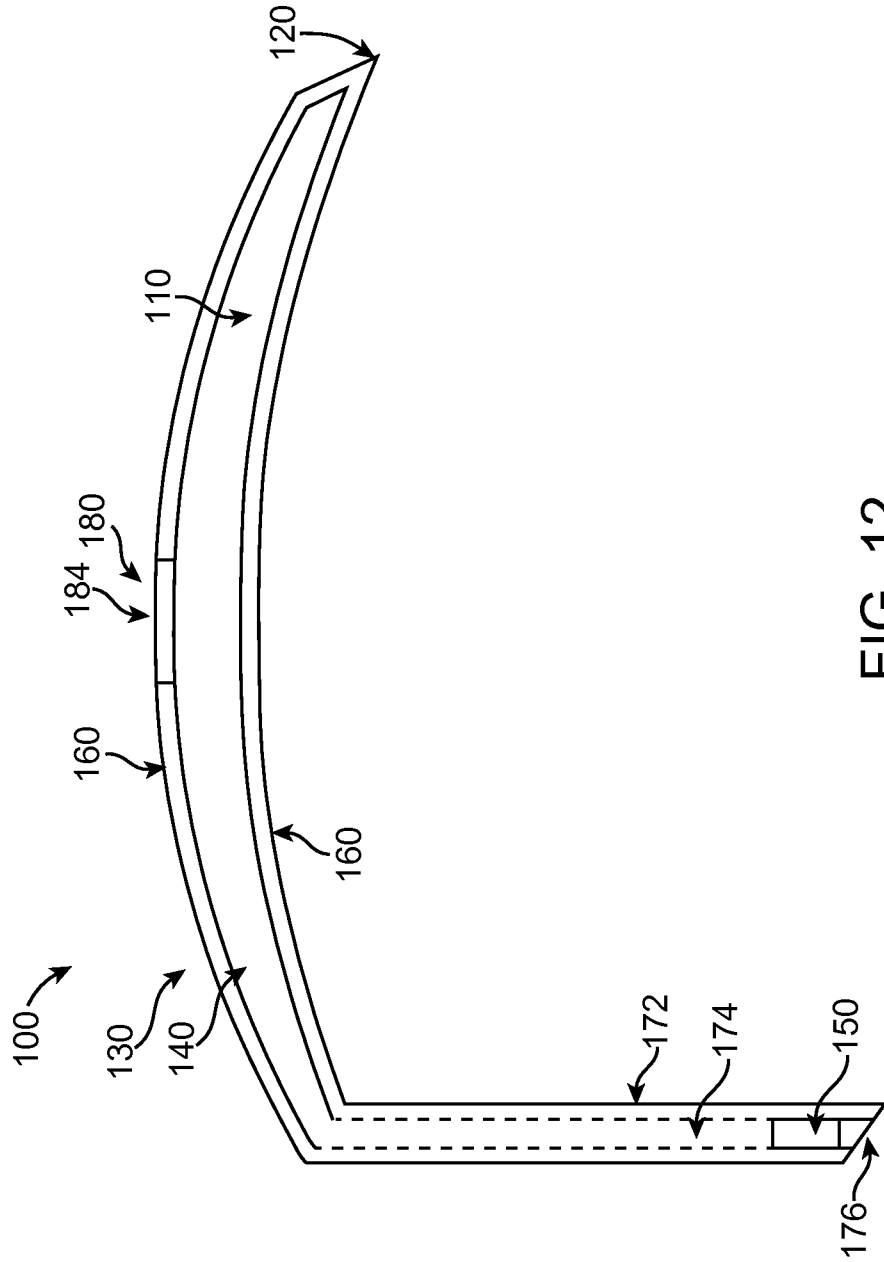

FIG. 12

27/56

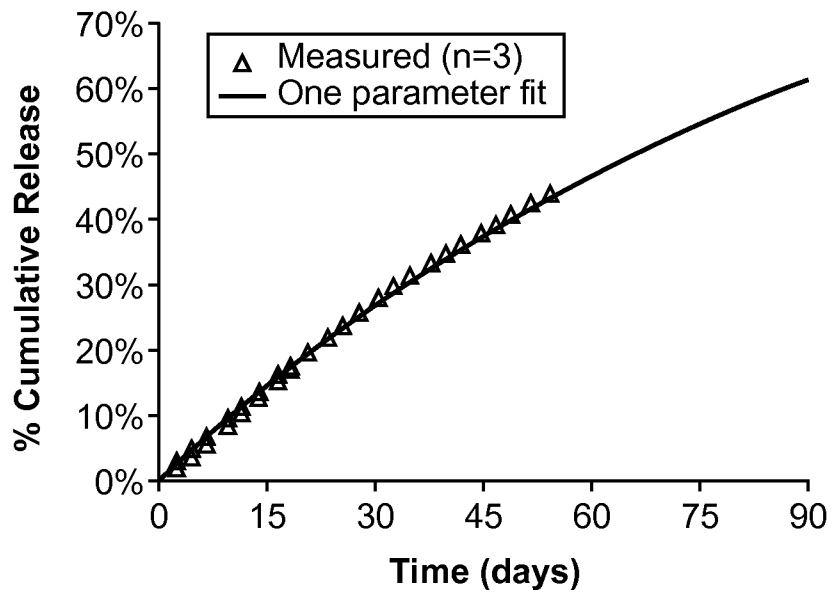

FIG. 13

28/56

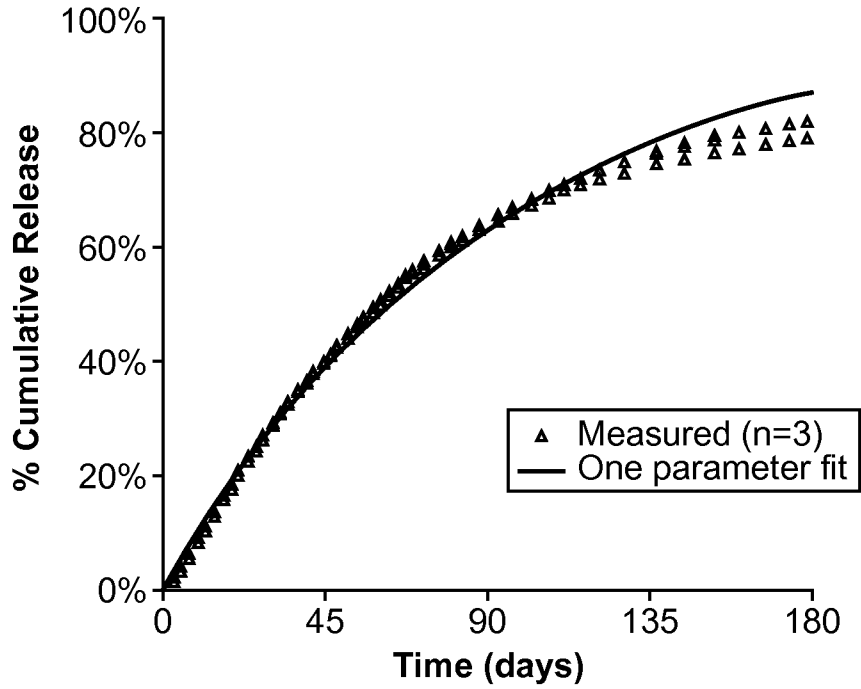

FIG. 13-1

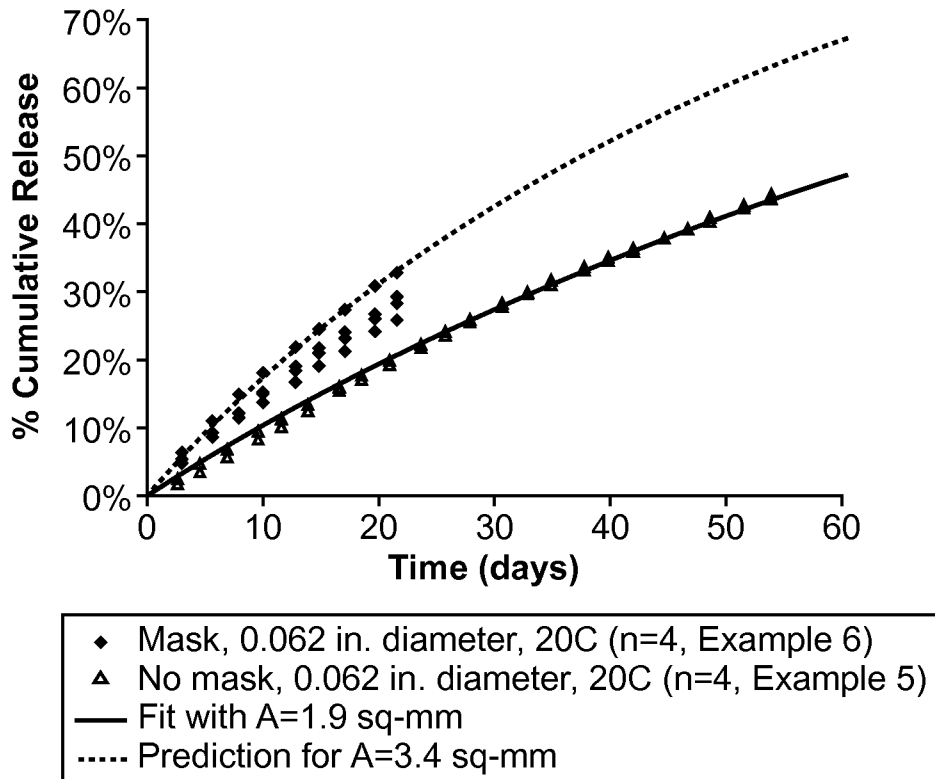

FIG. 14

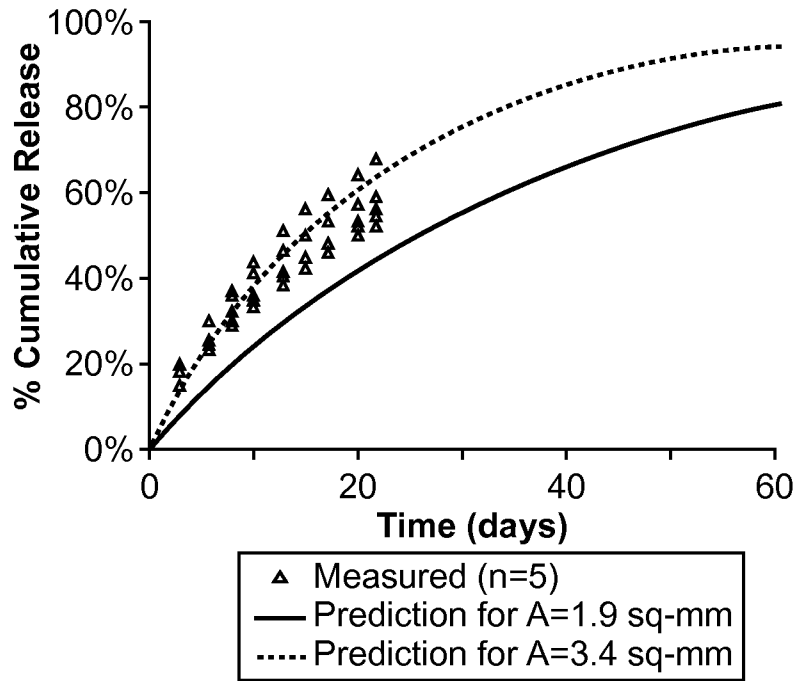

FIG. 15

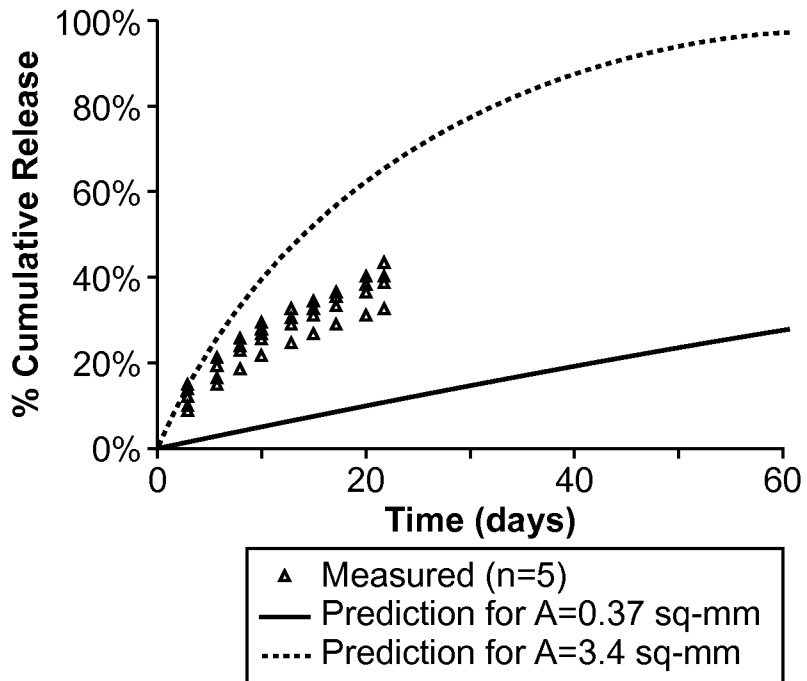

FIG. 16

30/56

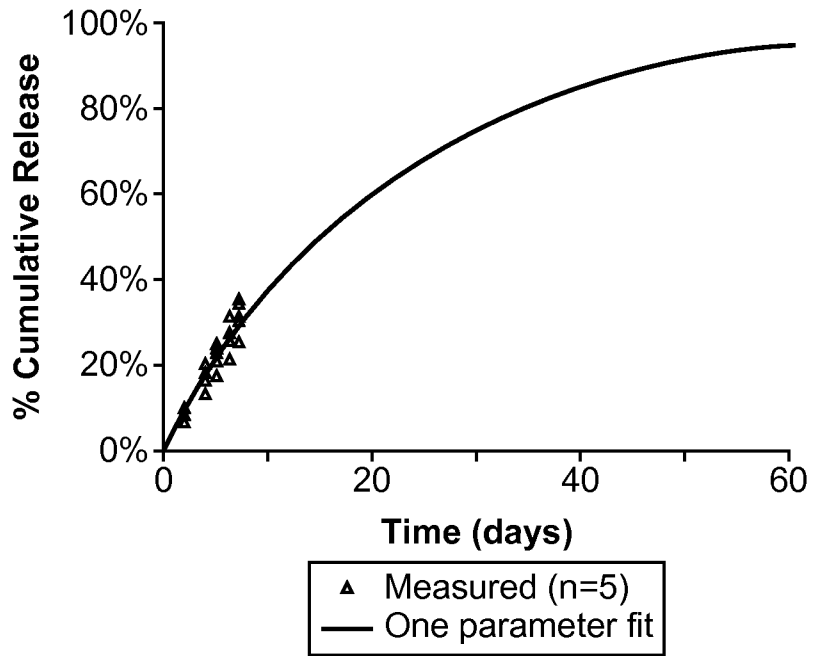

FIG. 17

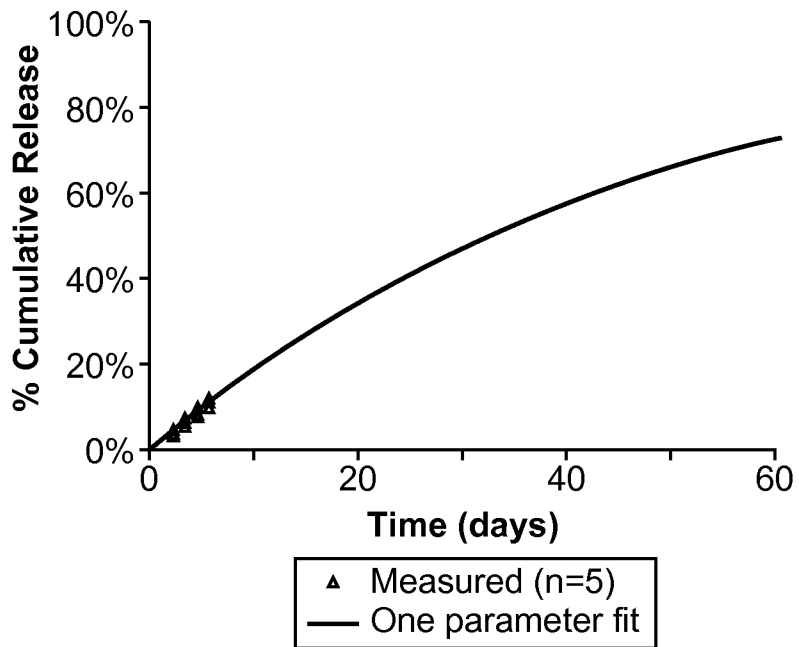

FIG. 18A

31/56

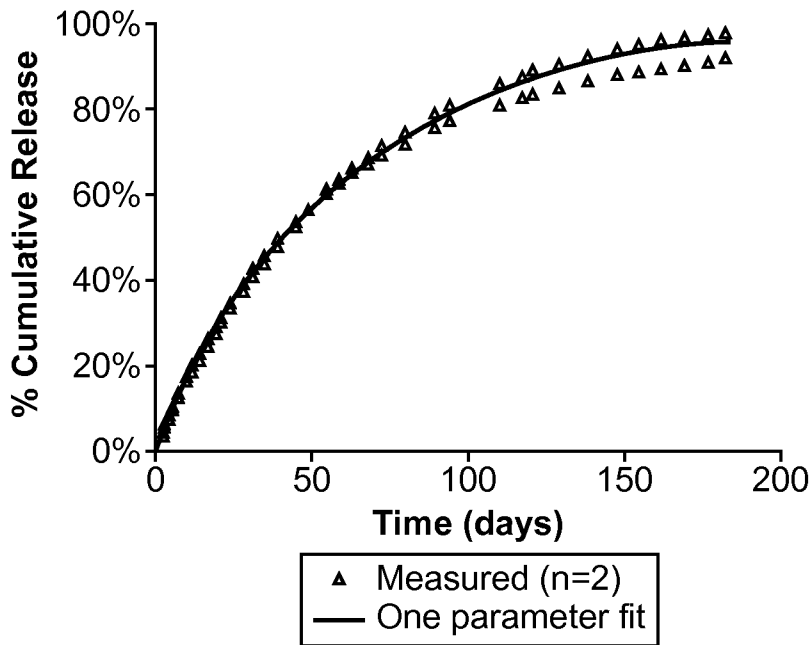

FIG. 18B

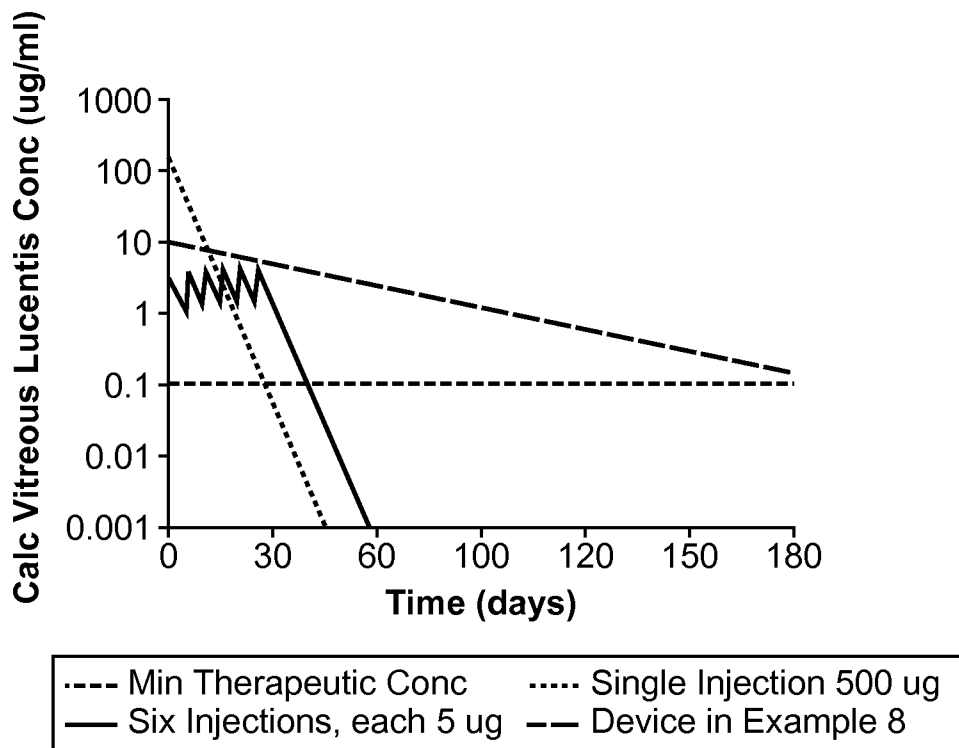

FIG. 19A



32/56

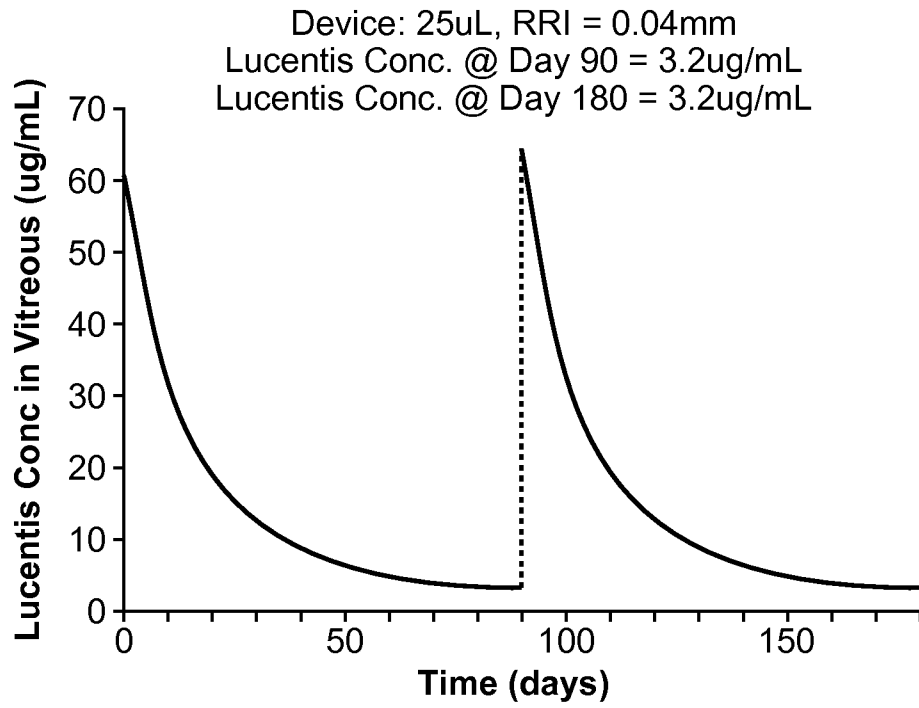

FIG. 19B

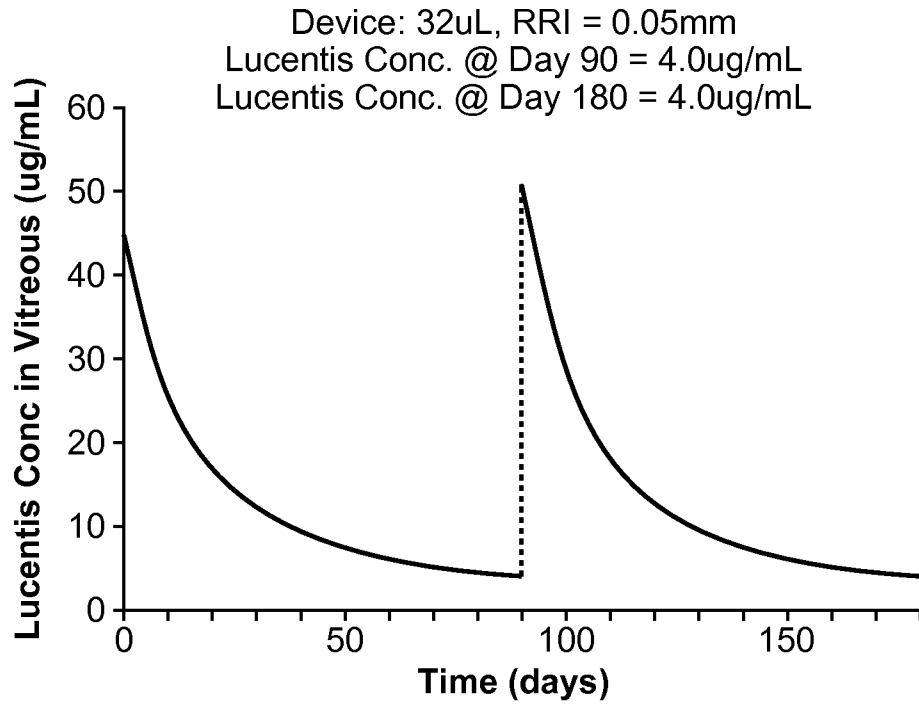

FIG. 19C

33/56

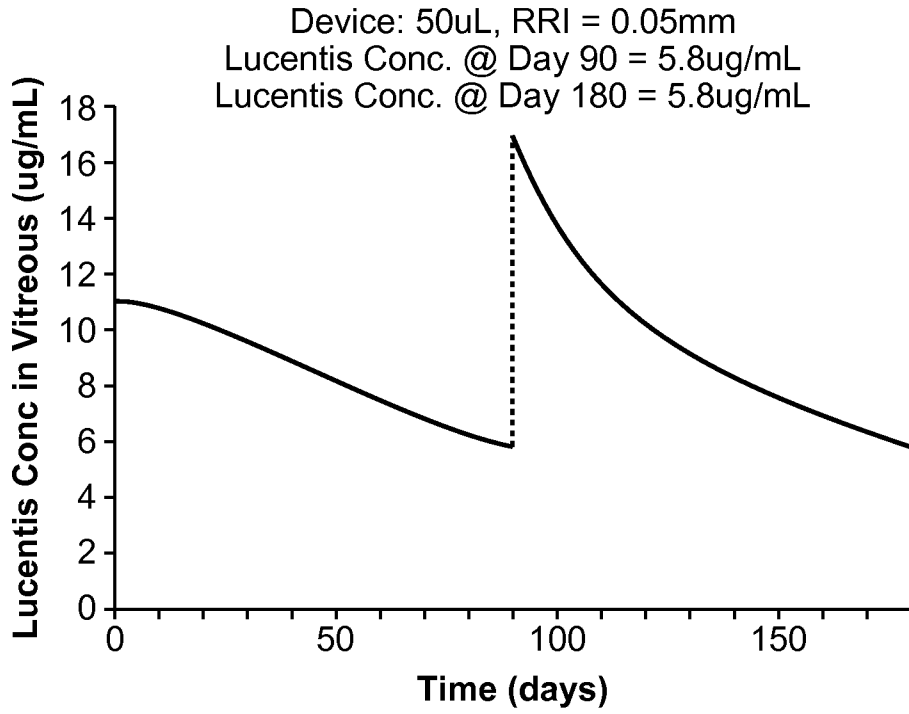

FIG. 19D

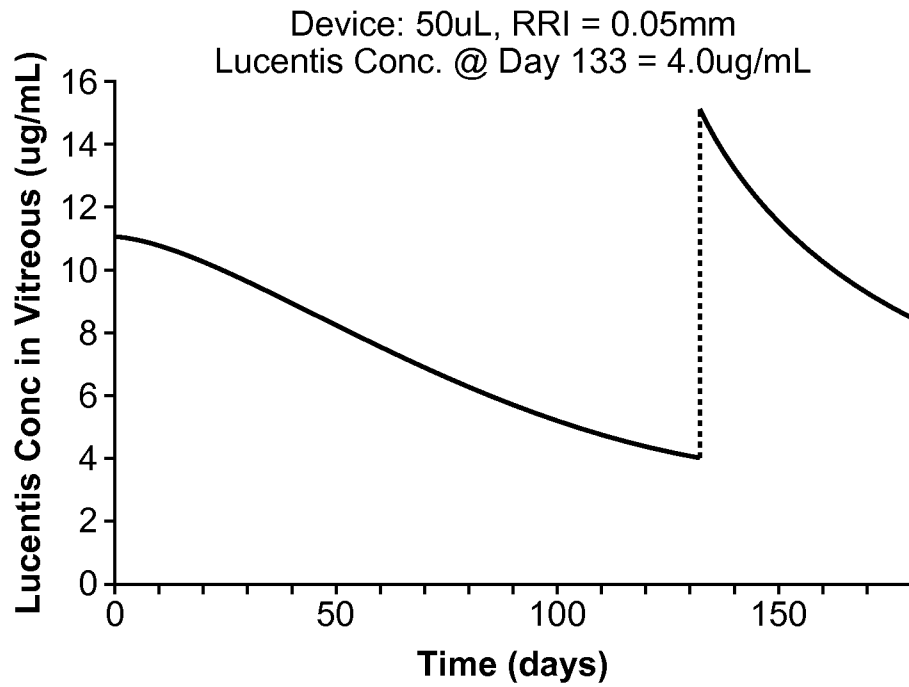

FIG. 19E

34/56

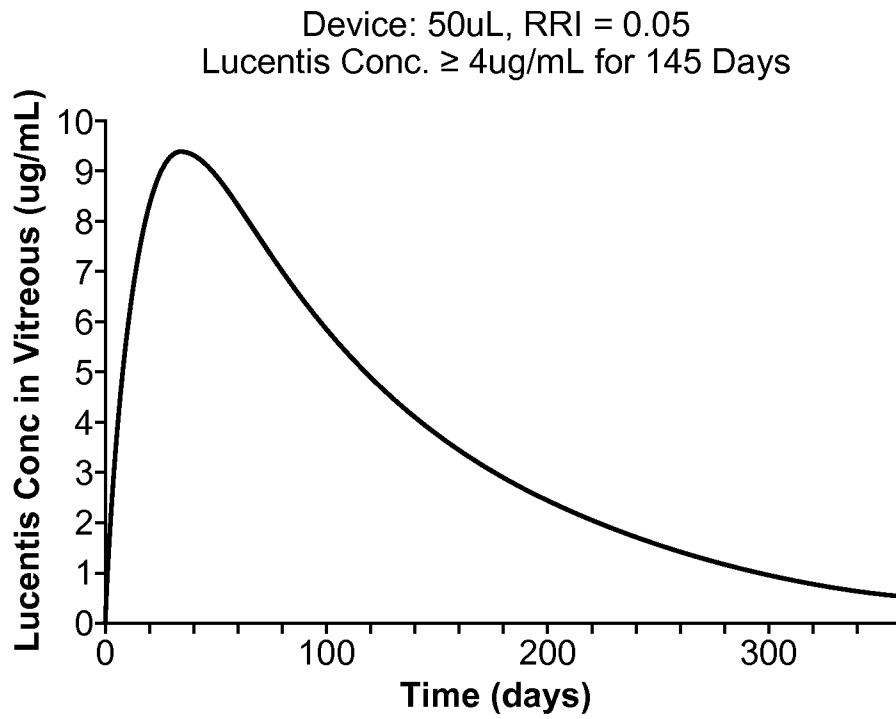

FIG. 19F

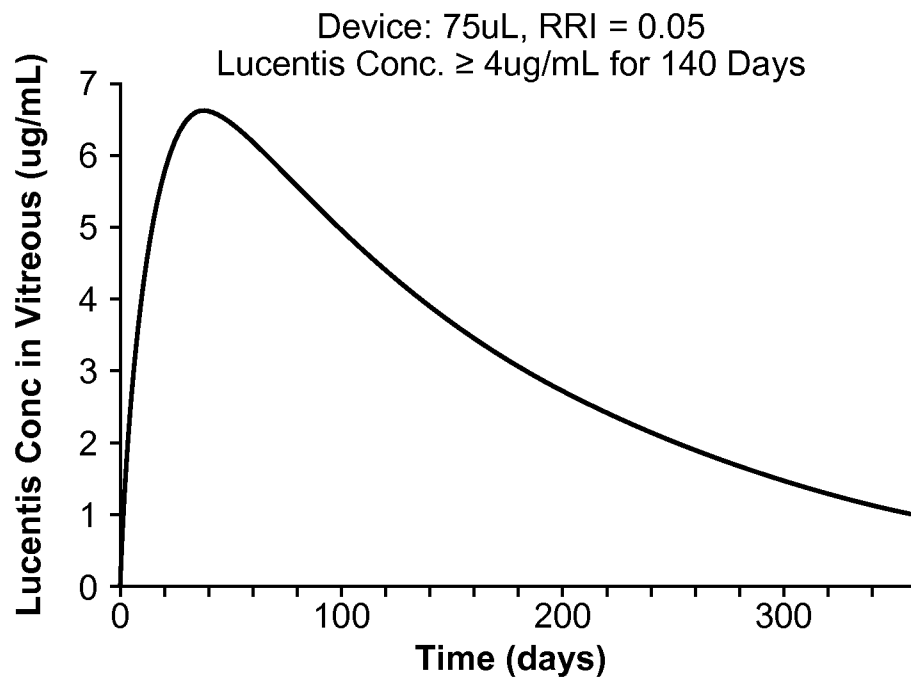

FIG. 19G

35/56

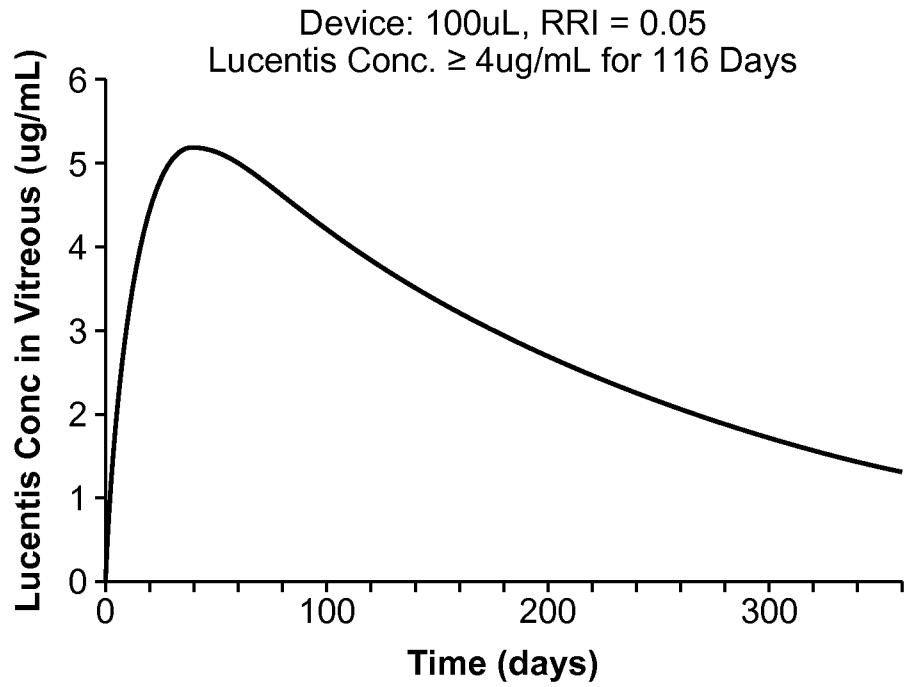

FIG. 19H

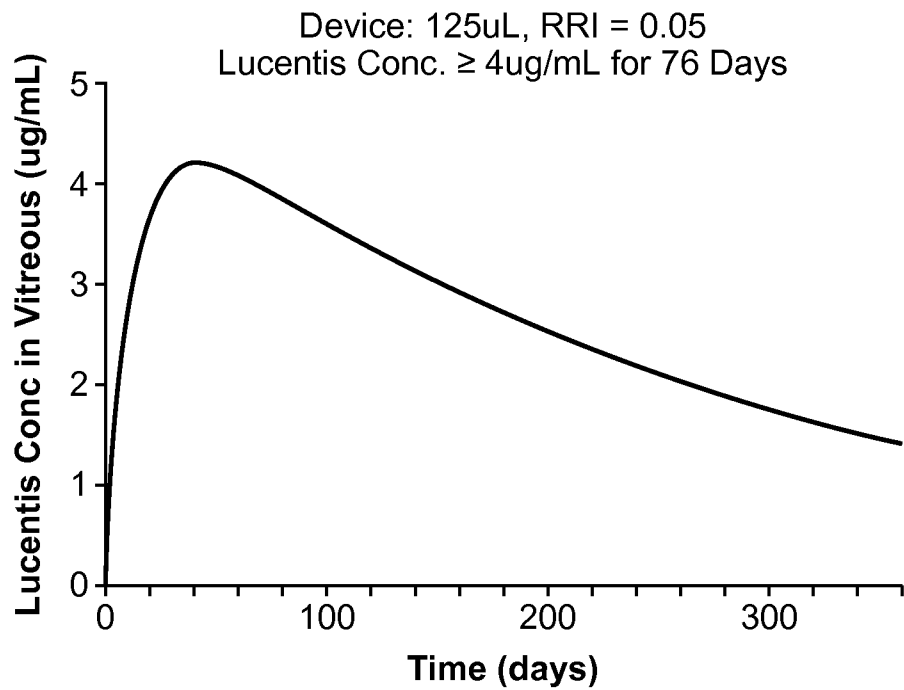

FIG. 19I

36/56

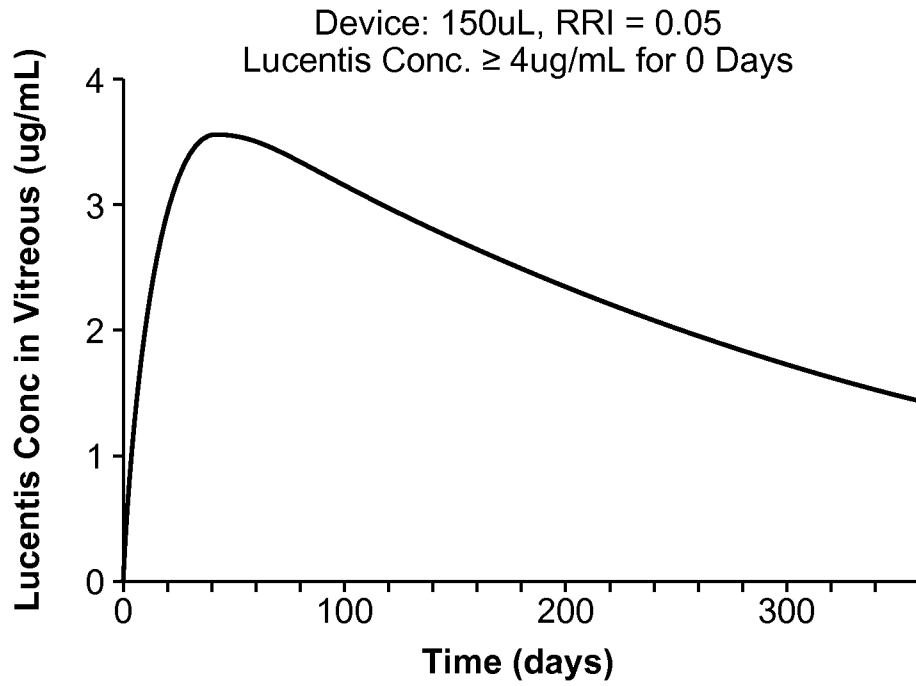

FIG. 19J

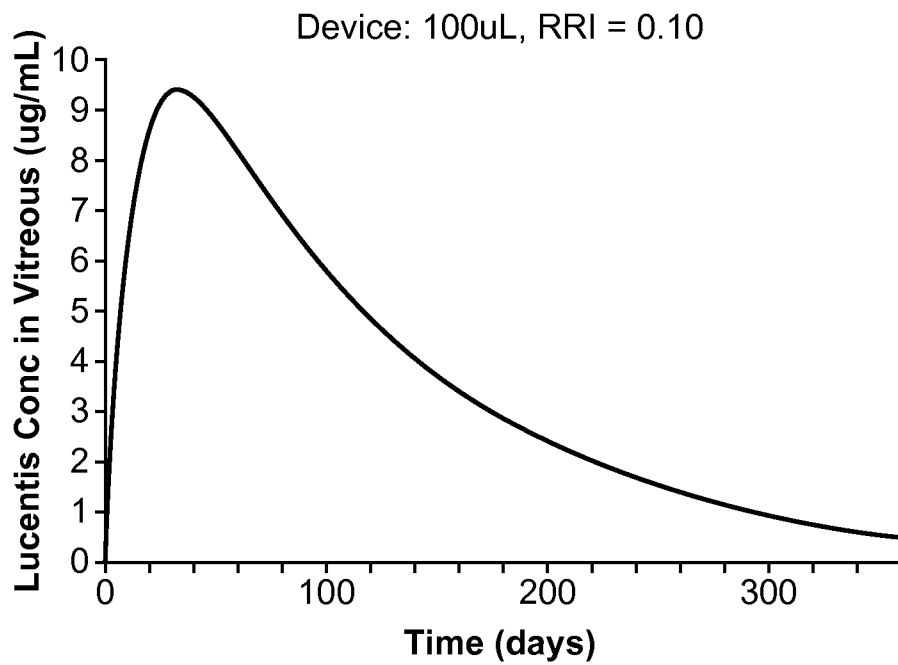

FIG. 19K

37/56

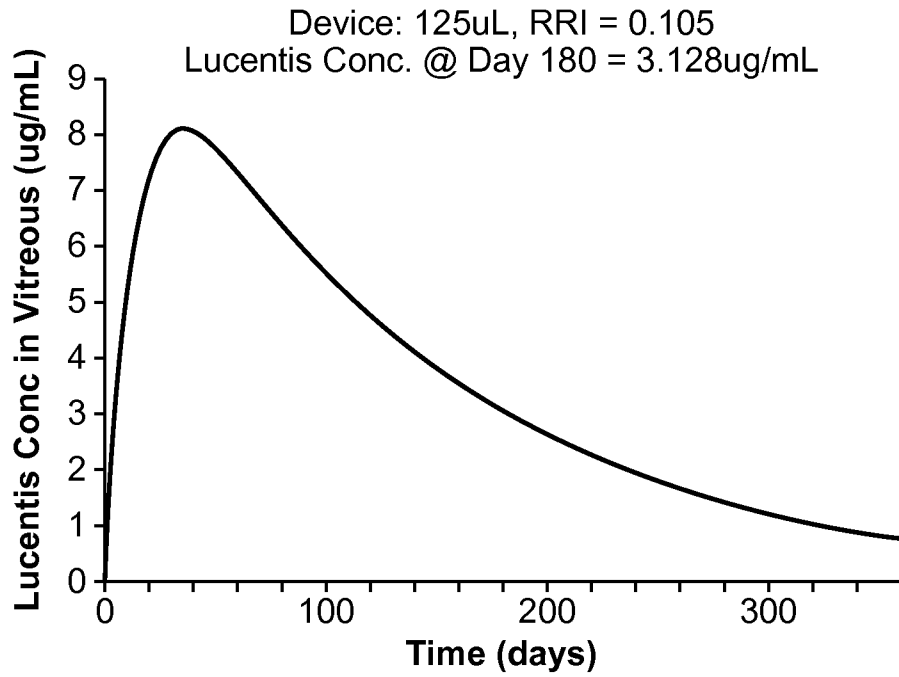

FIG. 19L

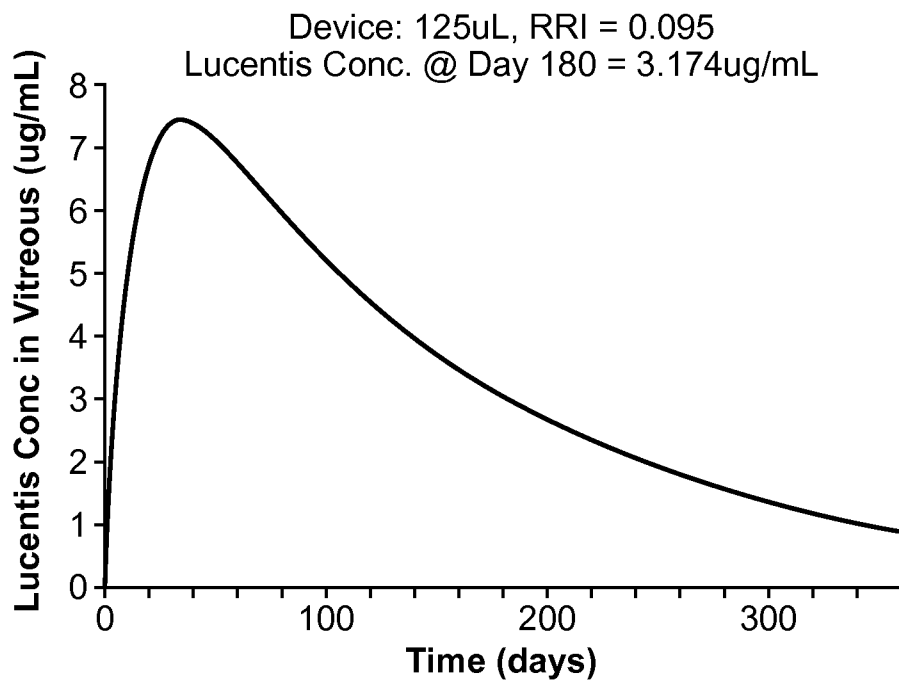

FIG. 19M

38/56

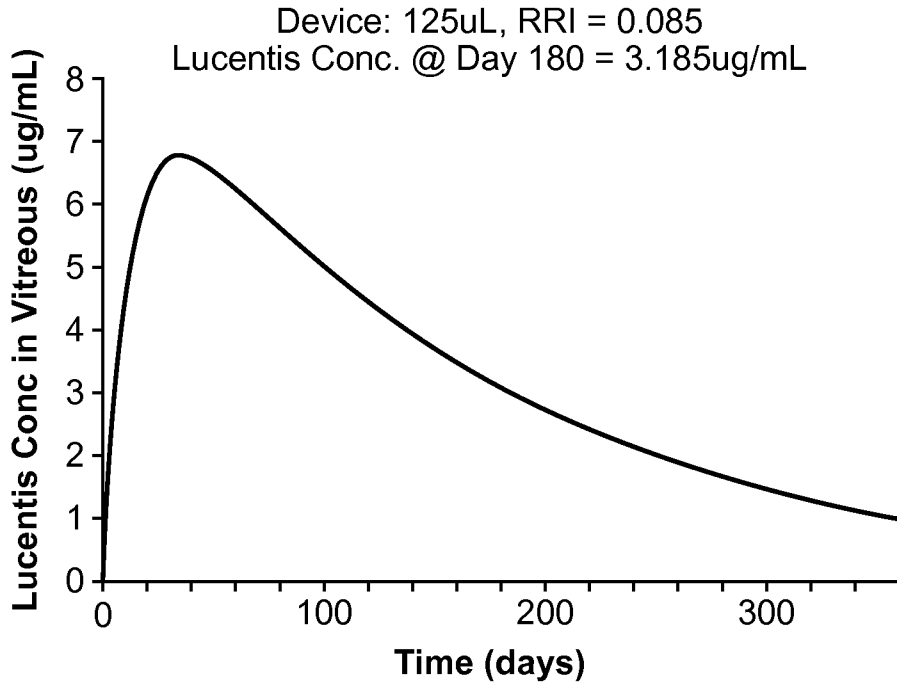

FIG. 19N

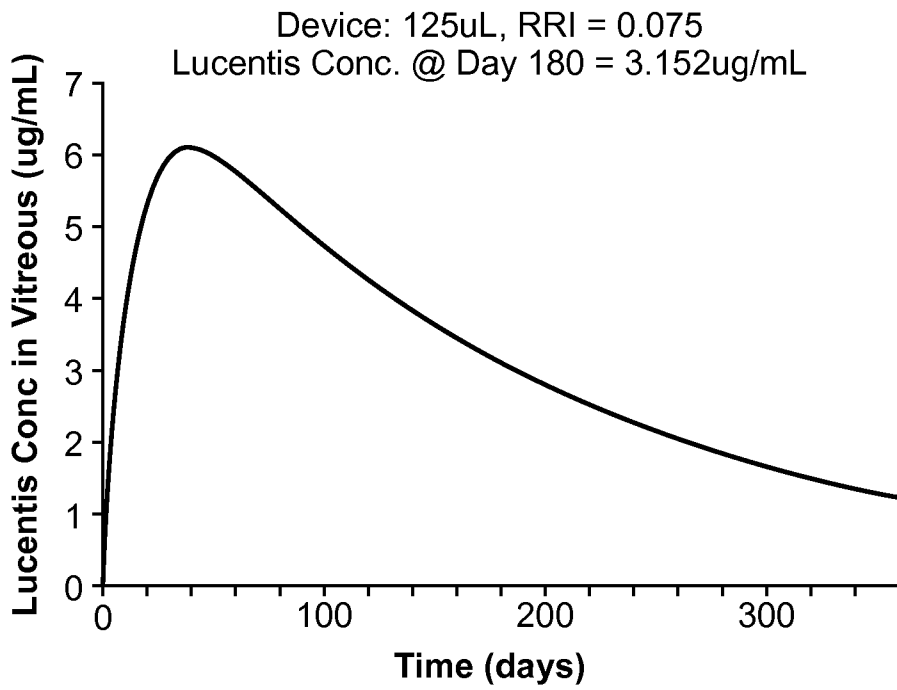

FIG. 19O

39/56

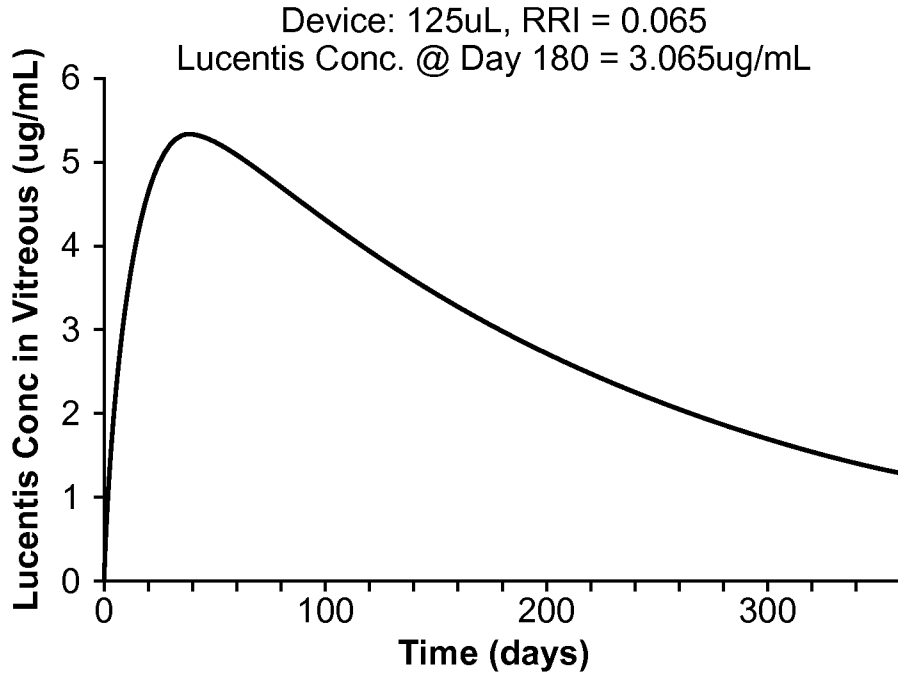

FIG. 19P

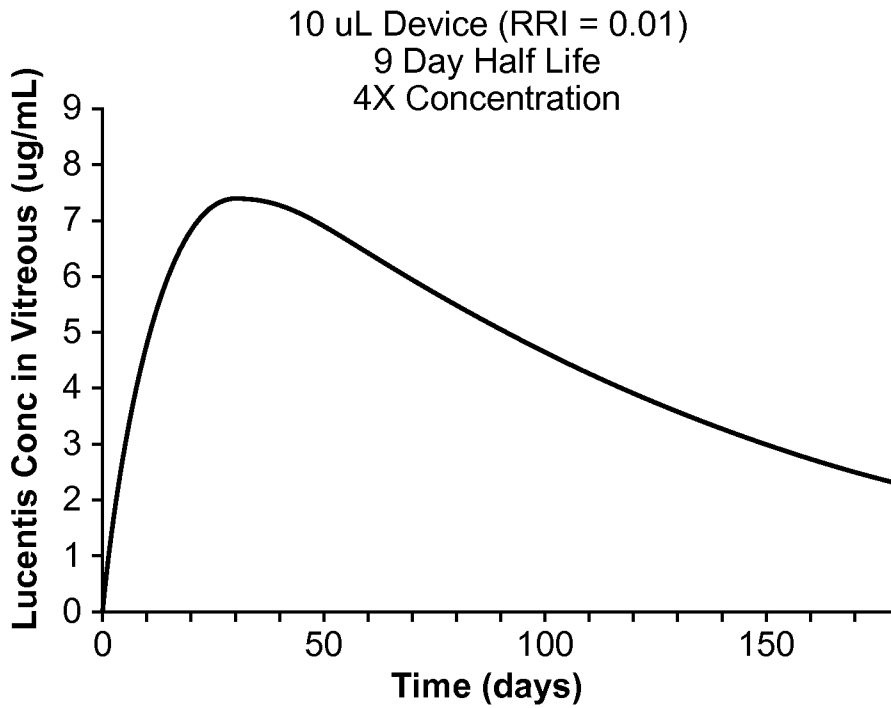

FIG. 19Q



40/56

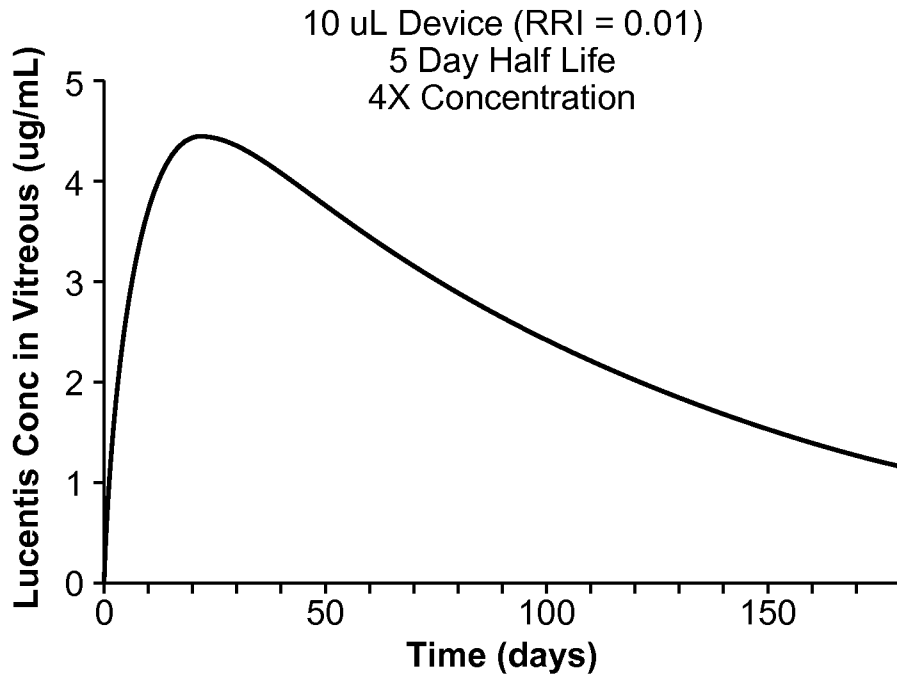

FIG. 19R

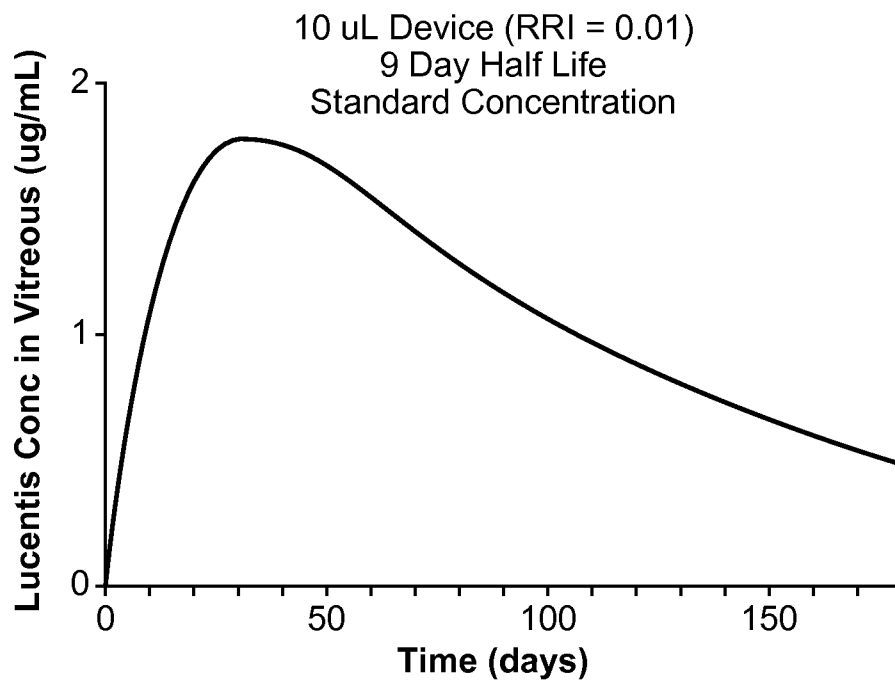

FIG. 19S

41/56

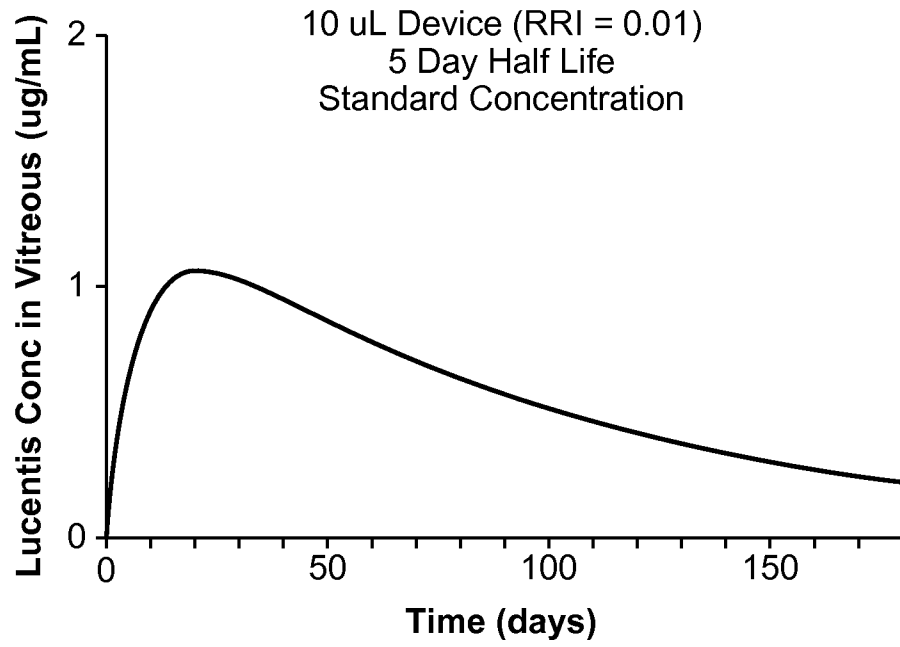

FIG. 19T

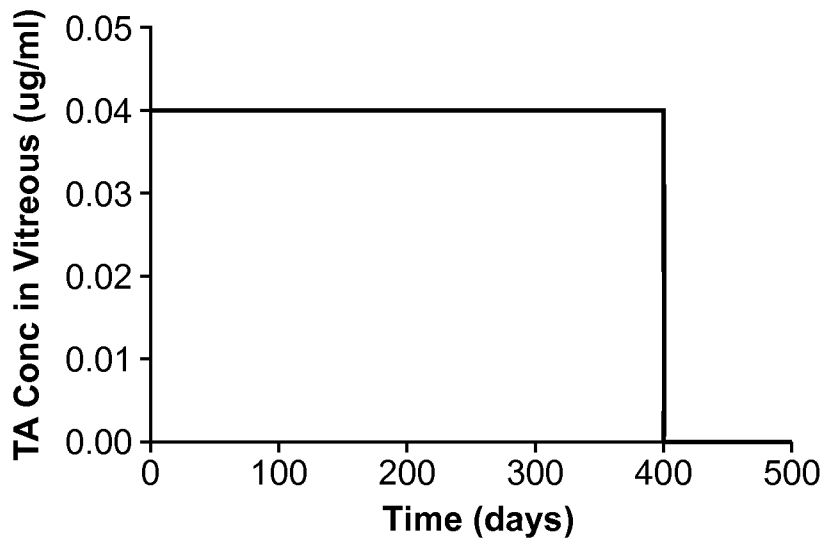

FIG. 20

42/56

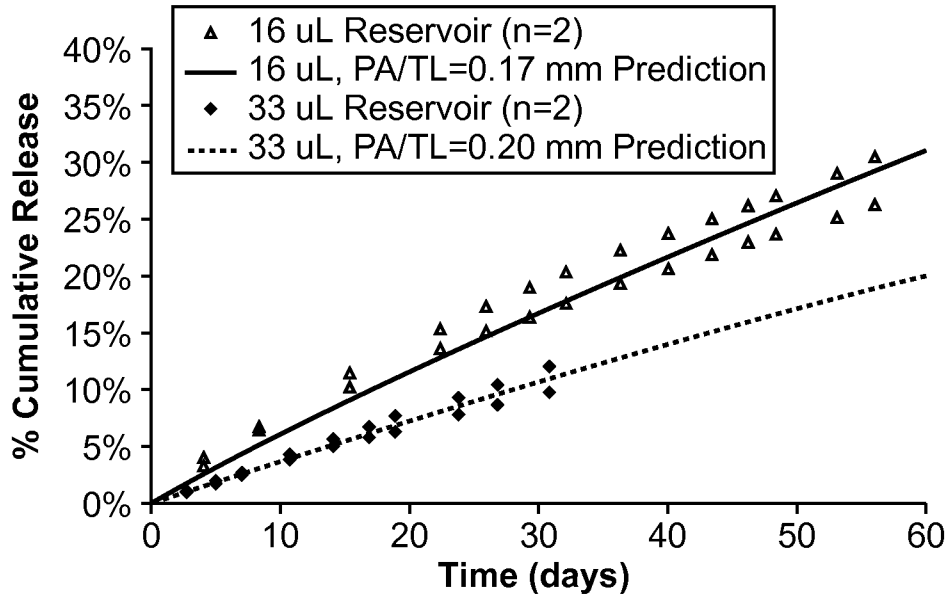

FIG. 21

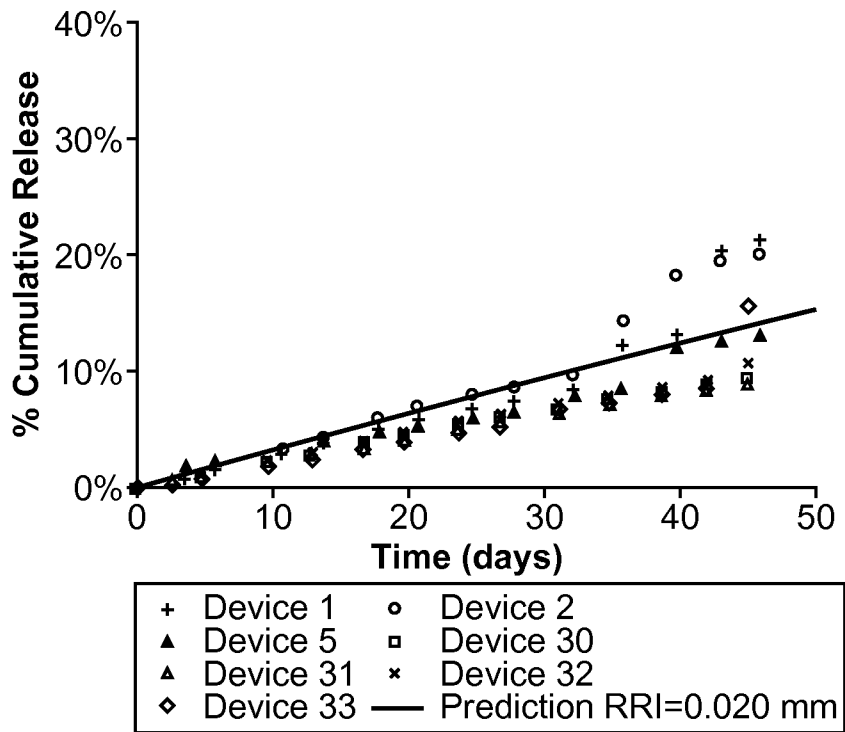

FIG. 22A

43/56

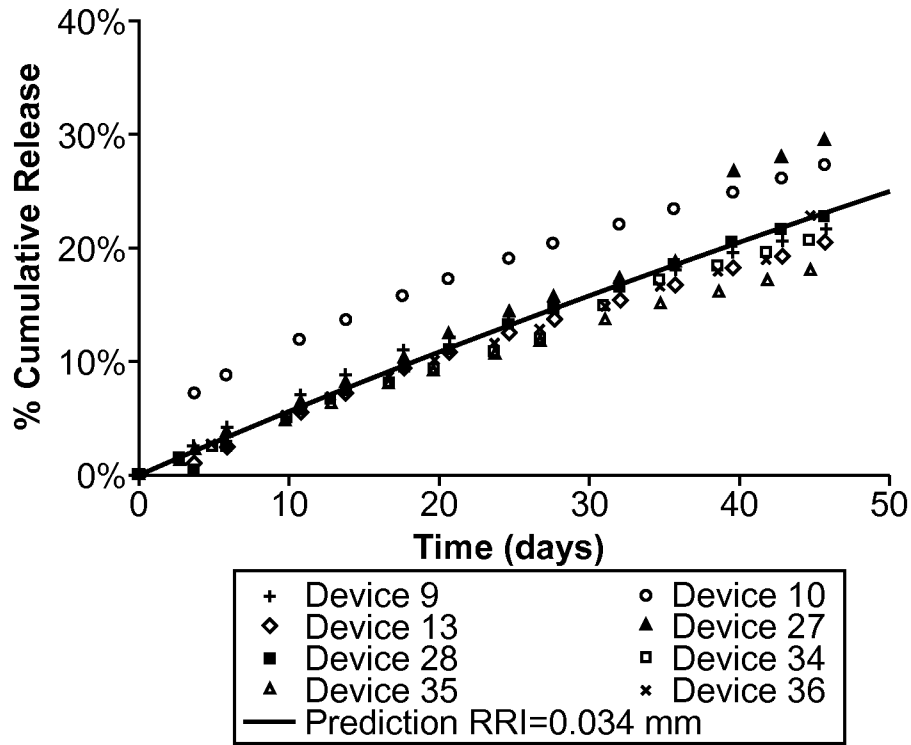

FIG. 22B-1

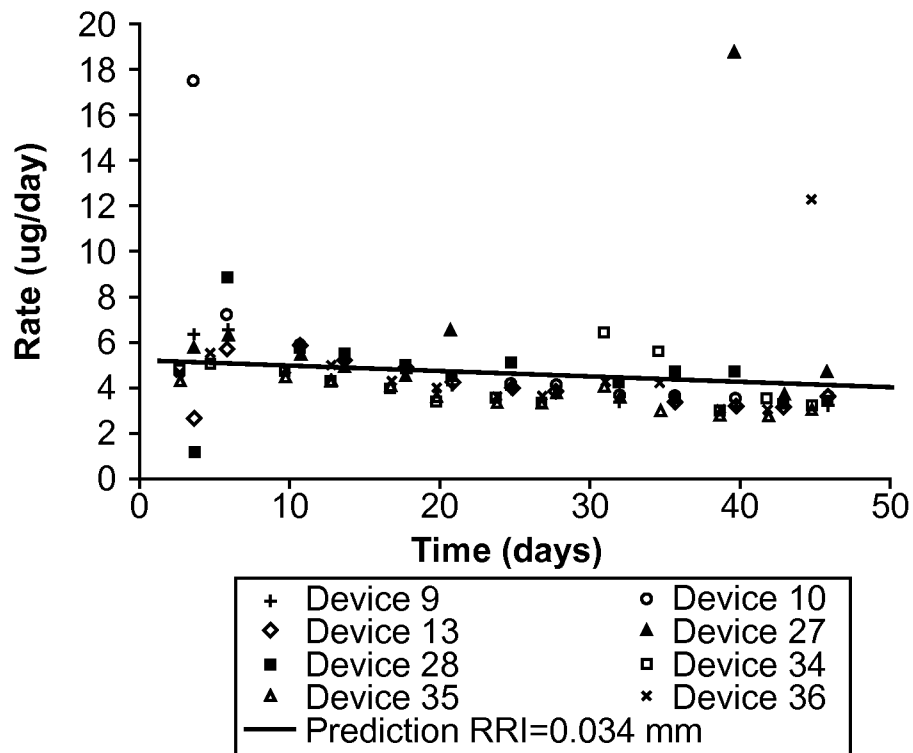

FIG. 22B-2

44/56

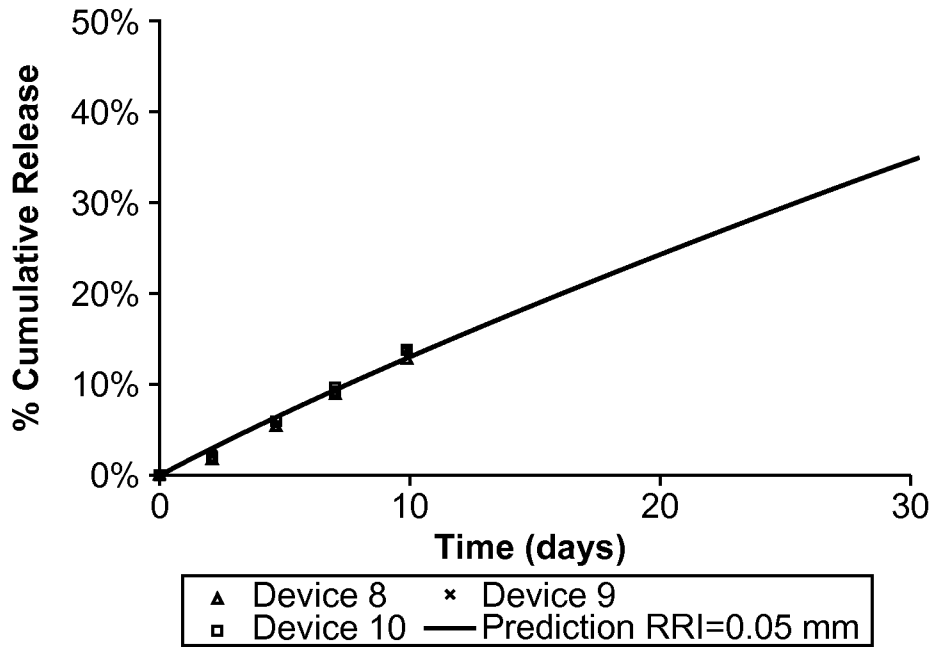

FIG. 23A

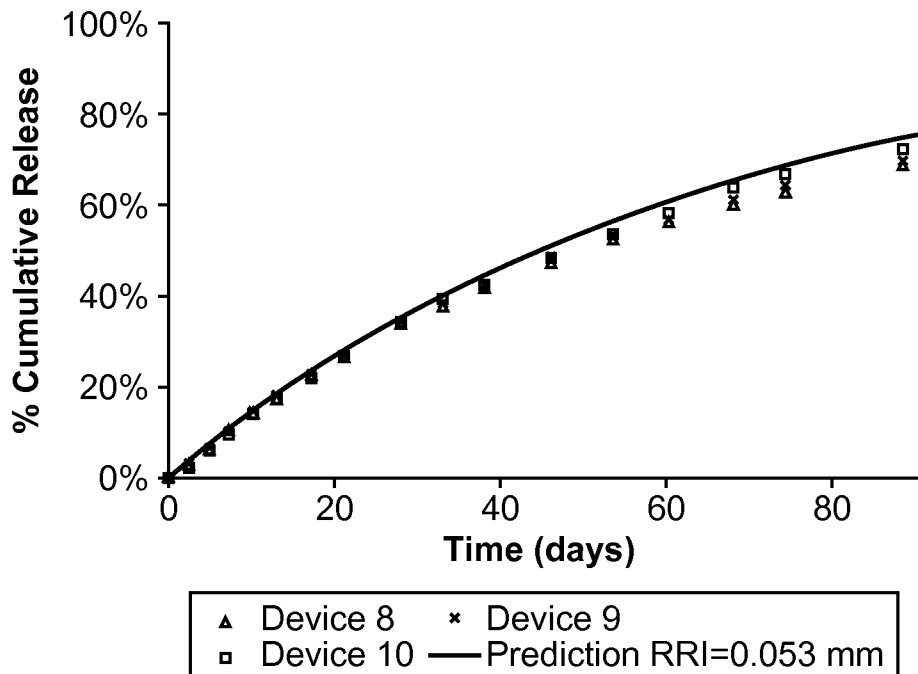

FIG. 23A-1

45/56

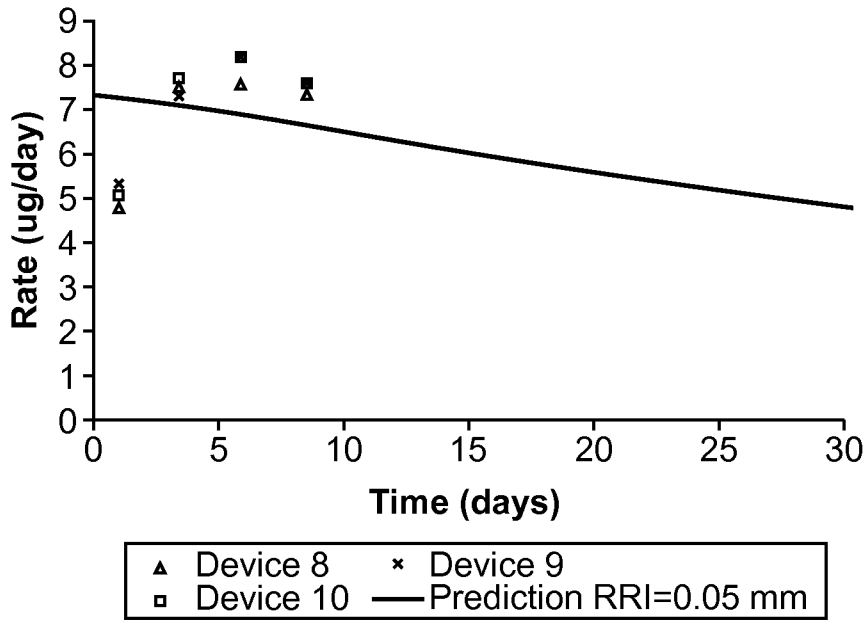

FIG. 23B

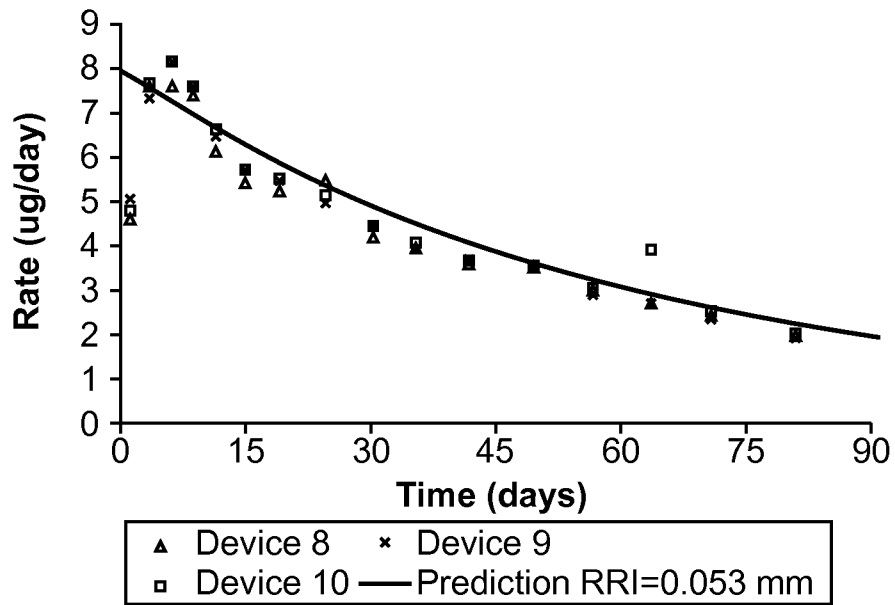

FIG. 23B-1

46/56

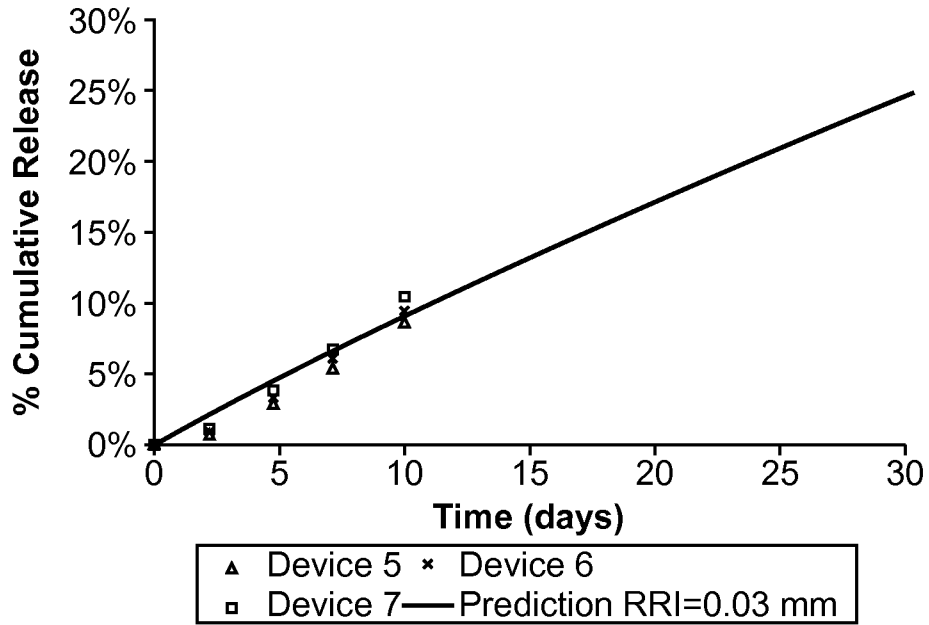

FIG. 24A

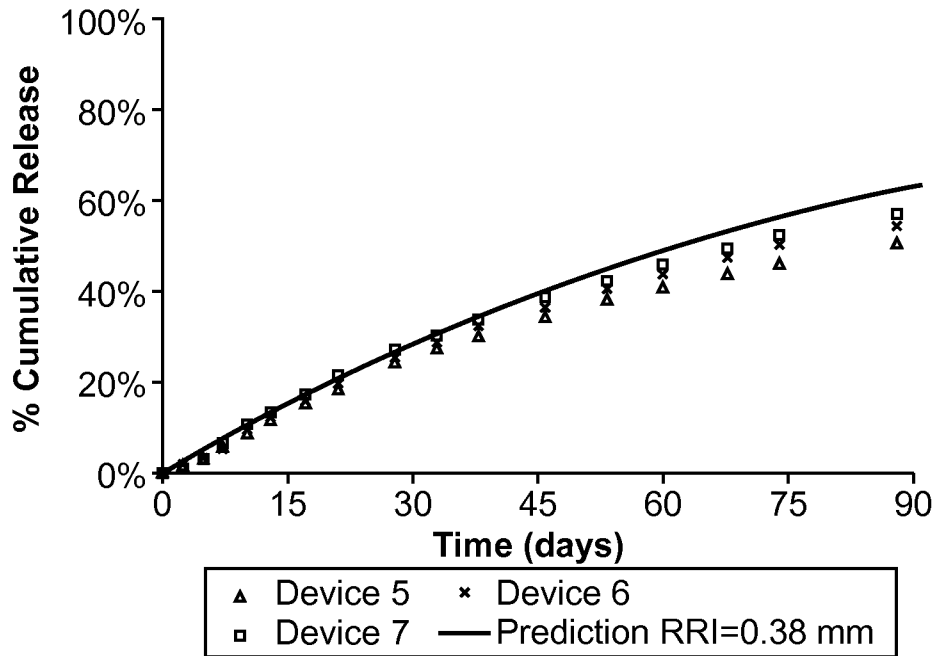

FIG. 24A-1

47/56

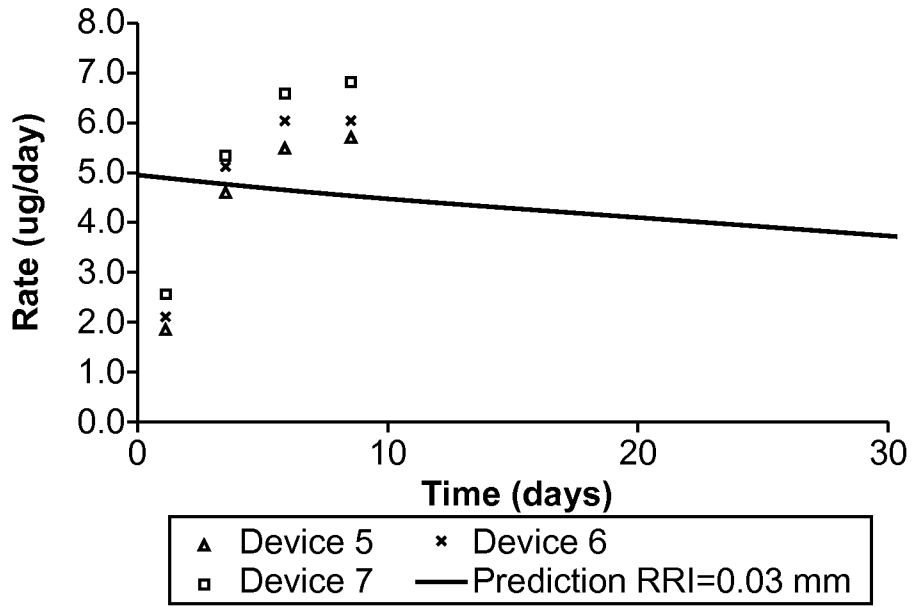

FIG. 24B

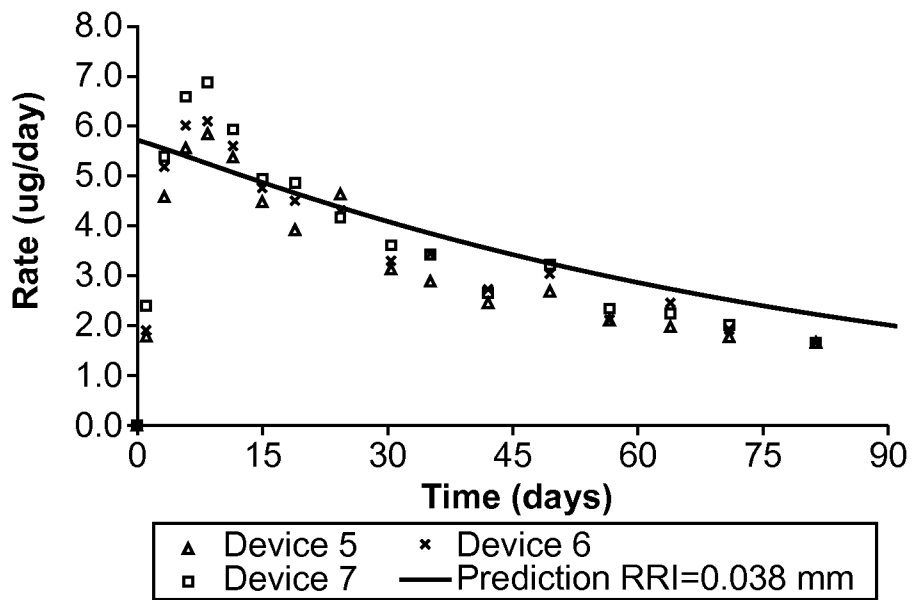

FIG. 24B-1



48/56

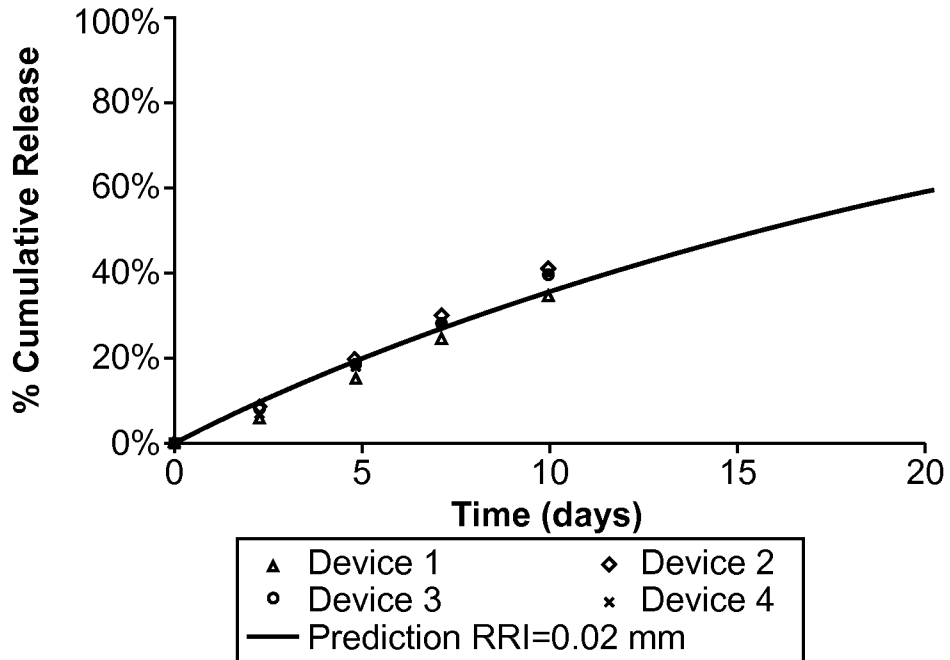

FIG. 25A

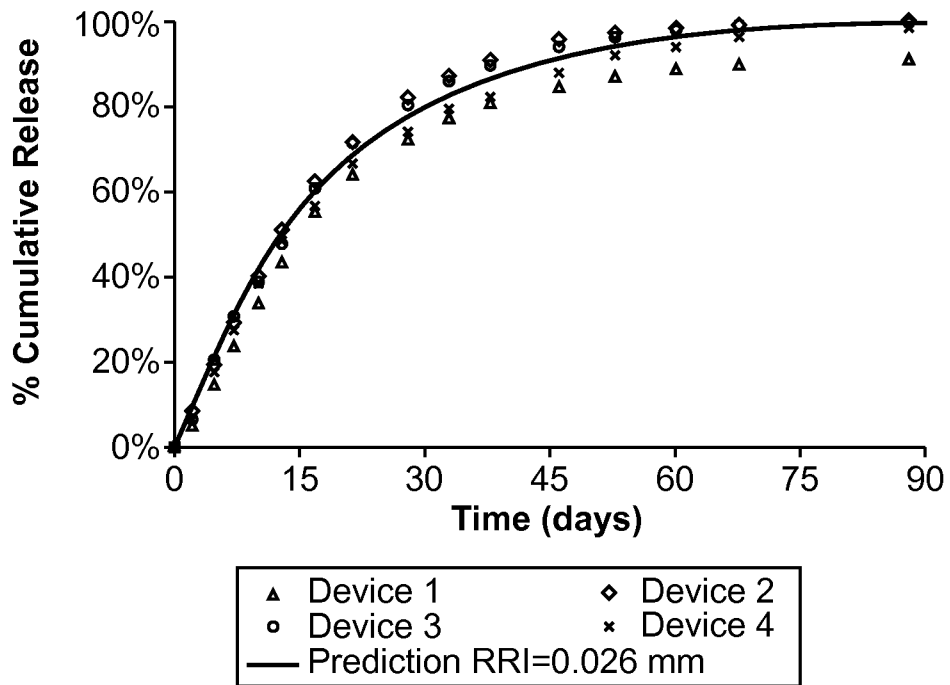

FIG. 25A-1

49/56

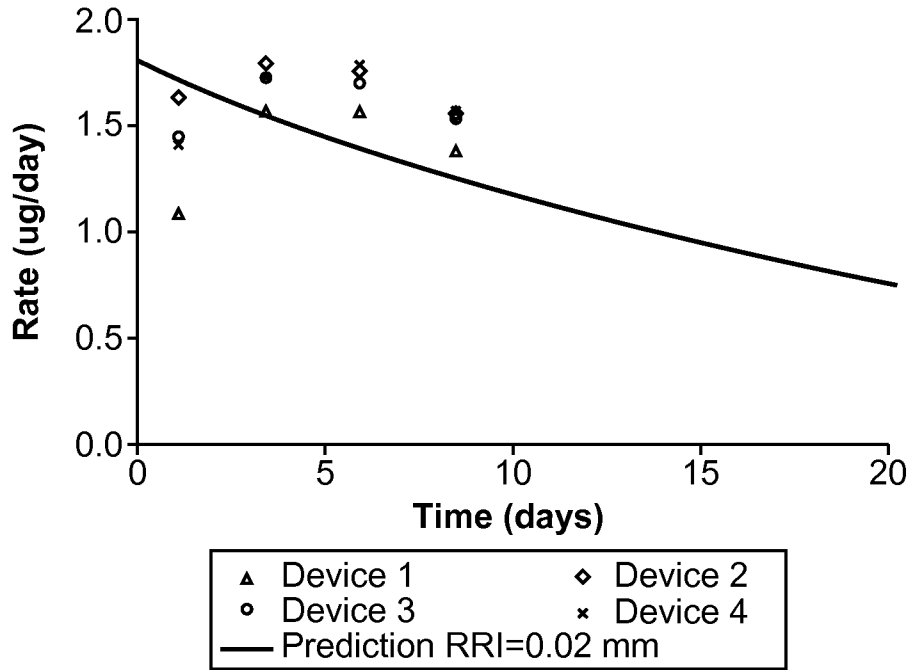

FIG. 25B

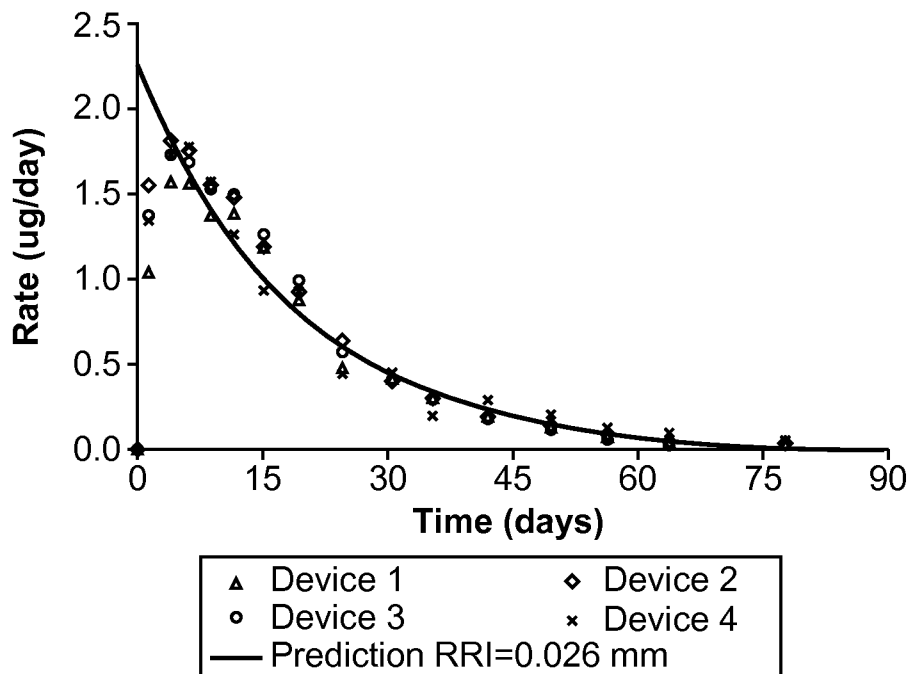

FIG. 25B-1

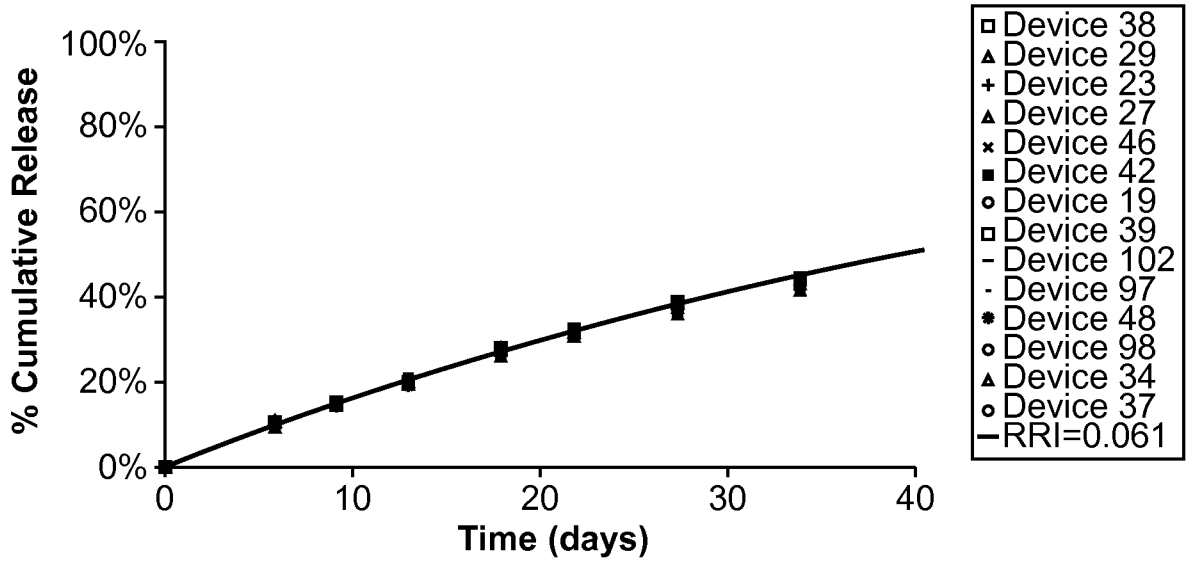

FIG. 25C

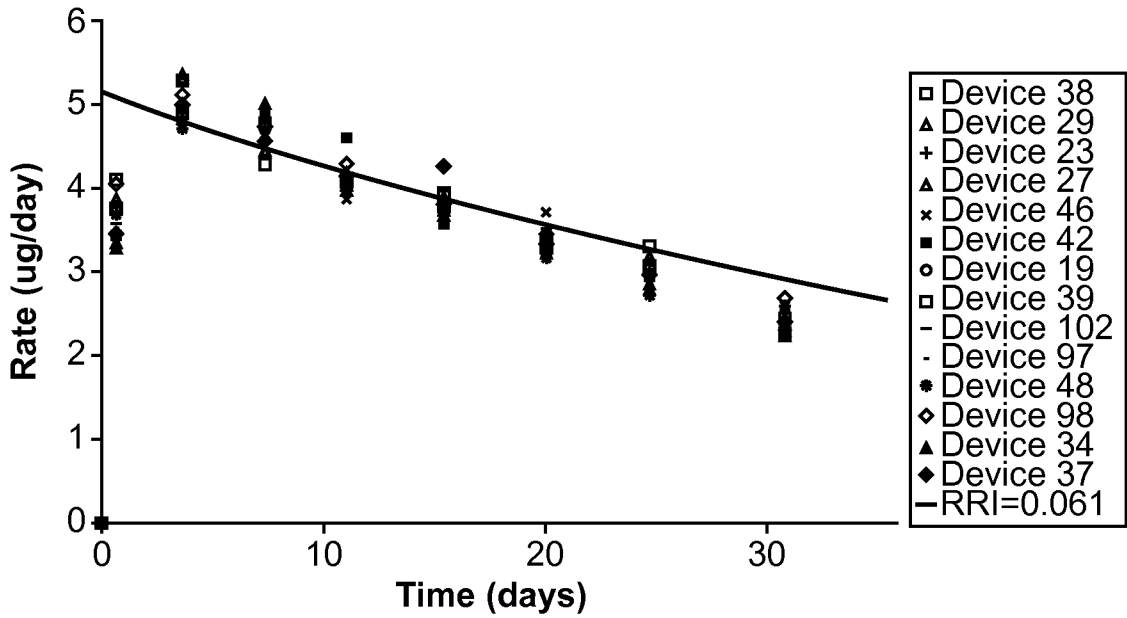

FIG. 25D

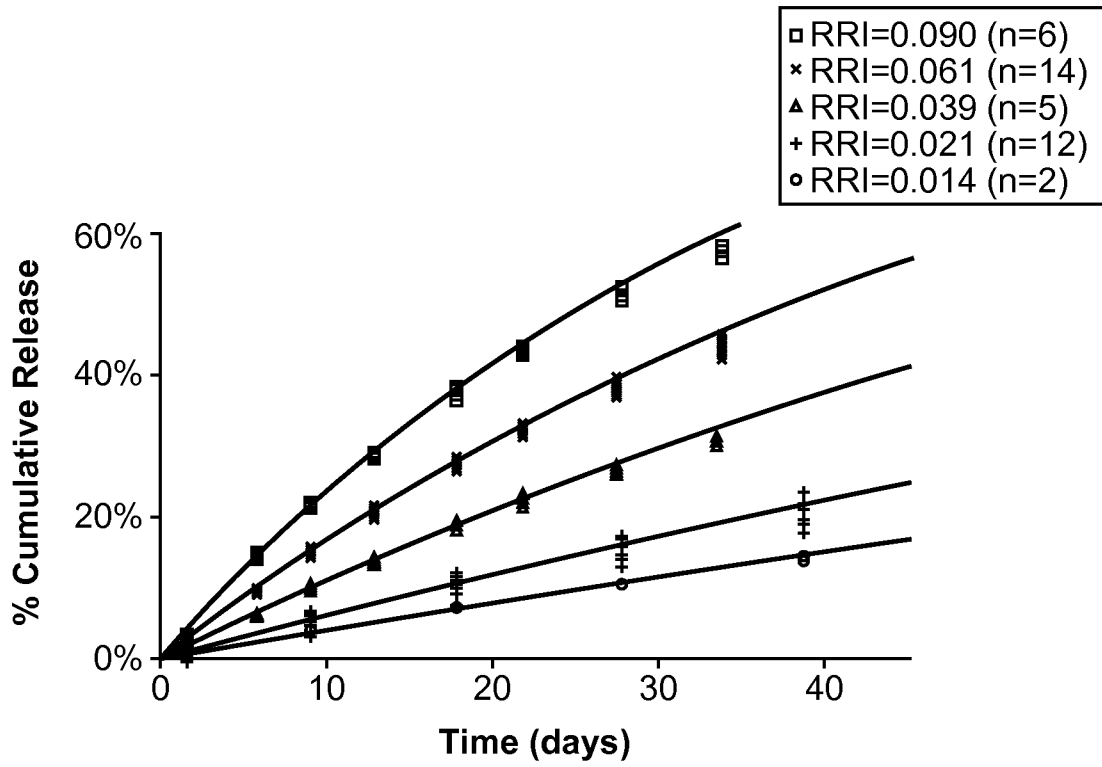

FIG. 25E

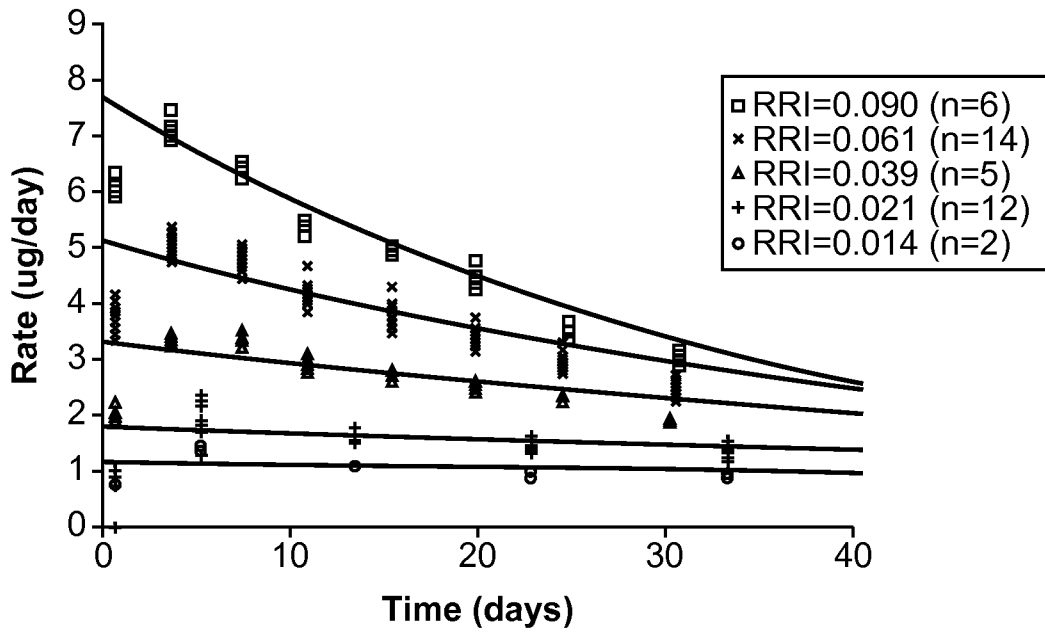

FIG. 25F

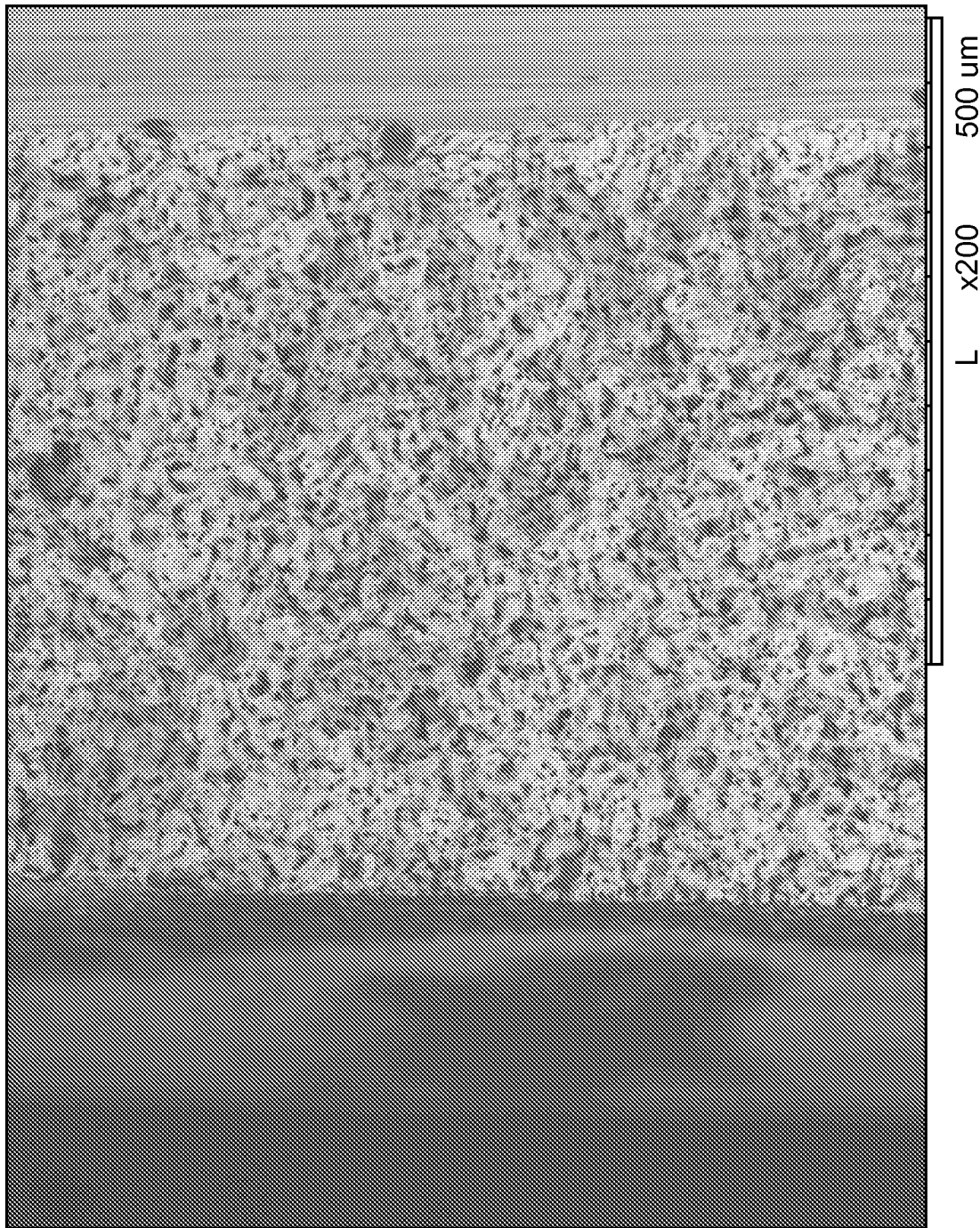

FIG. 26A

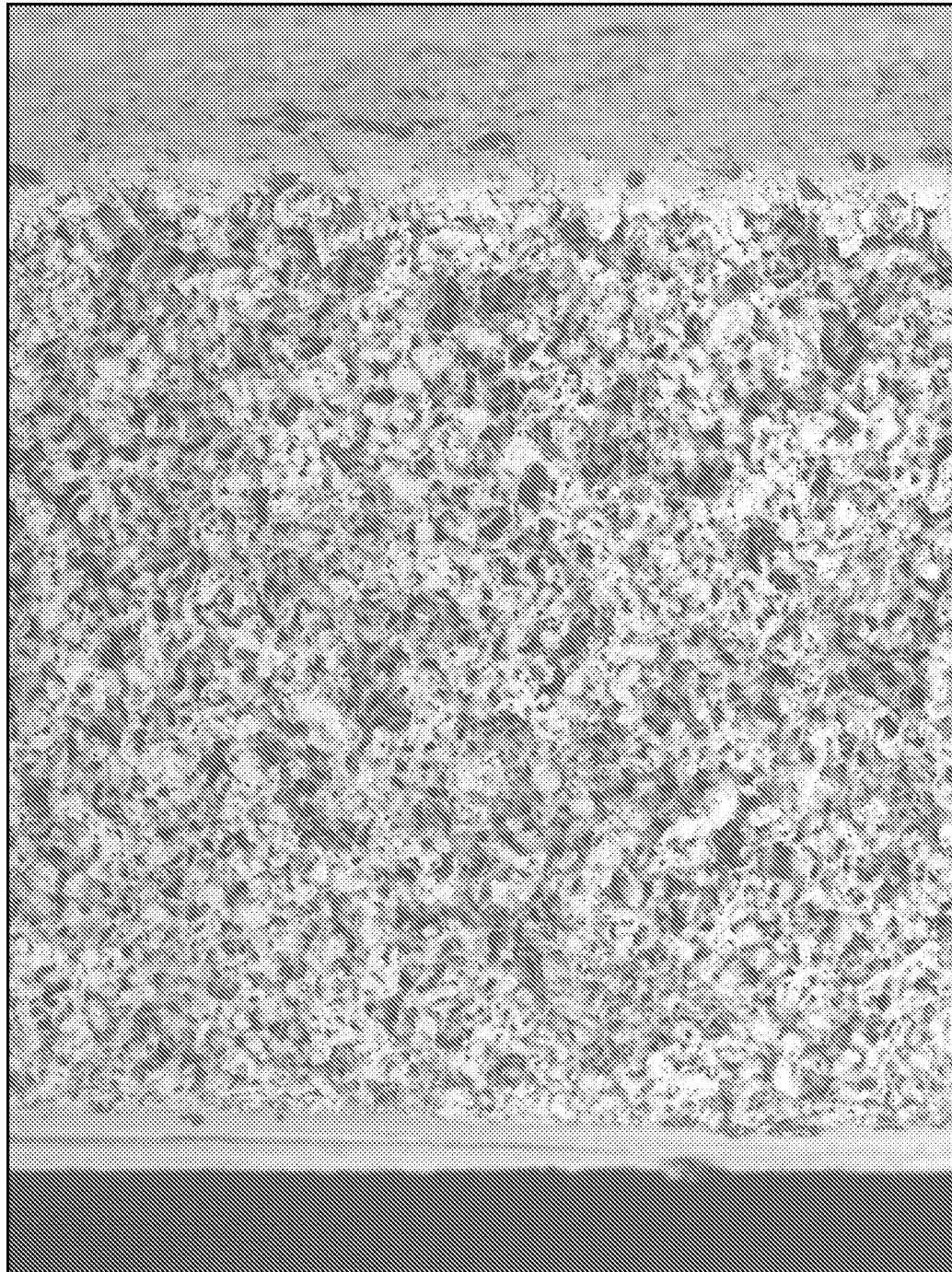

FIG. 26B

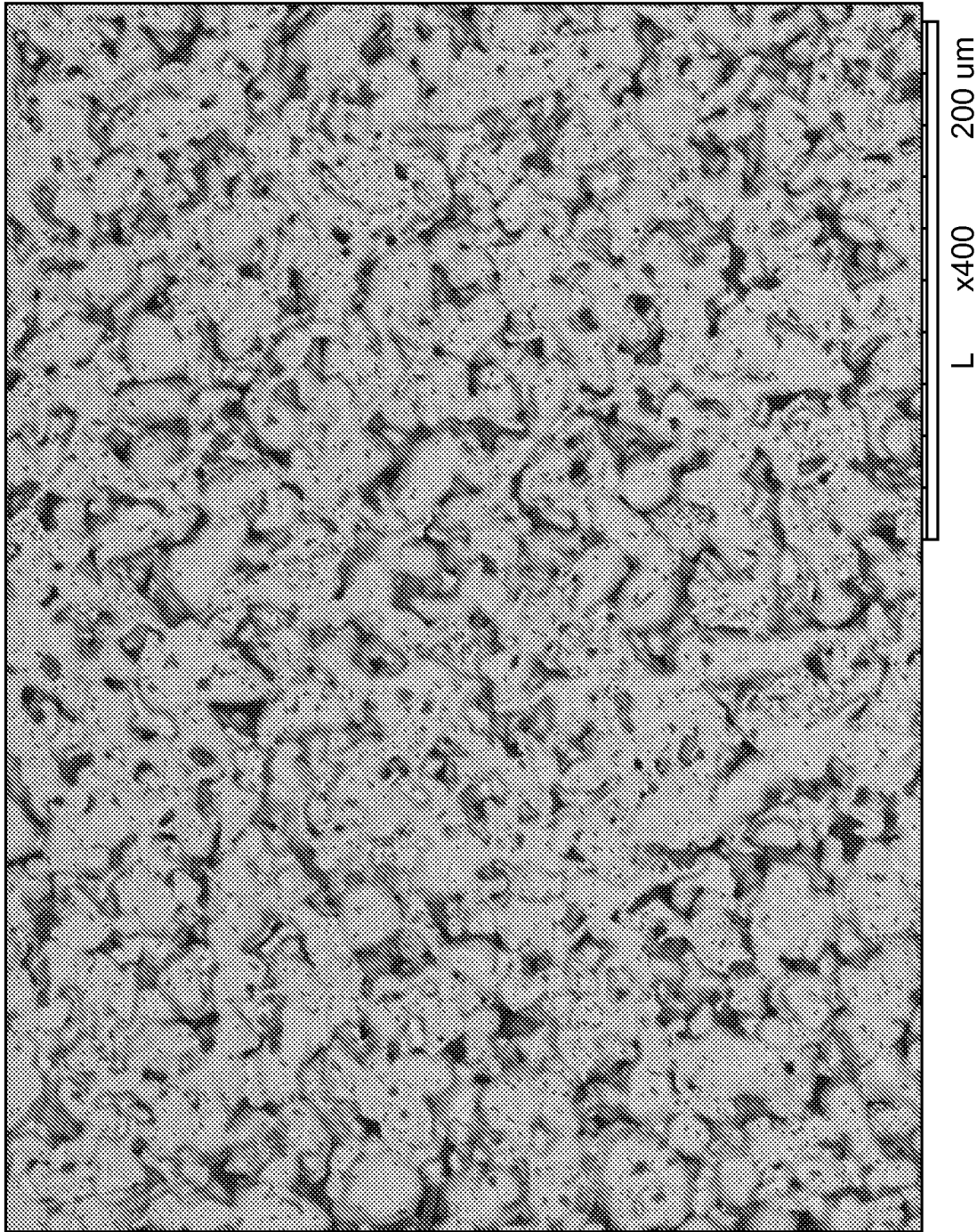

FIG. 27A



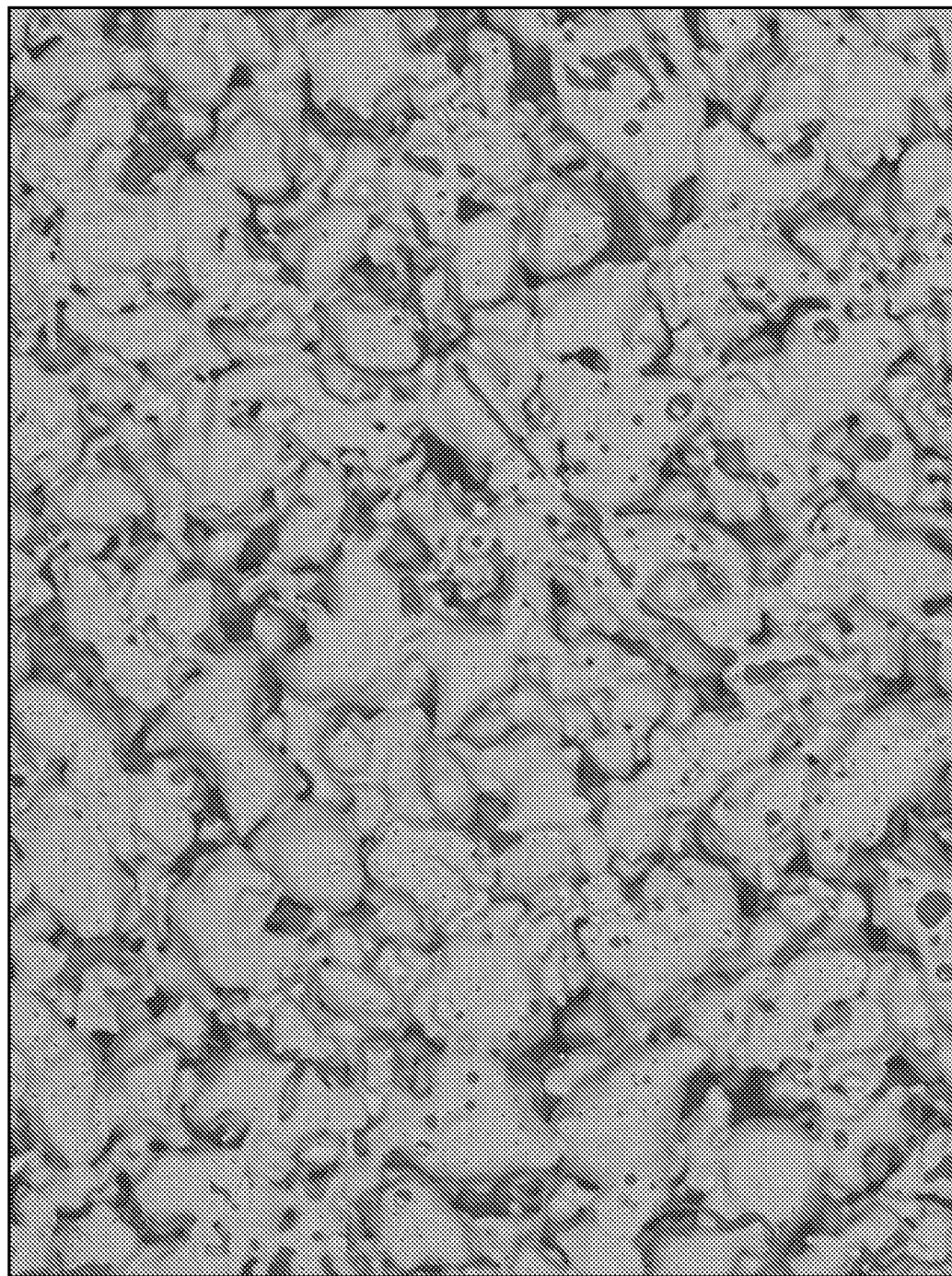

FIG. 27B



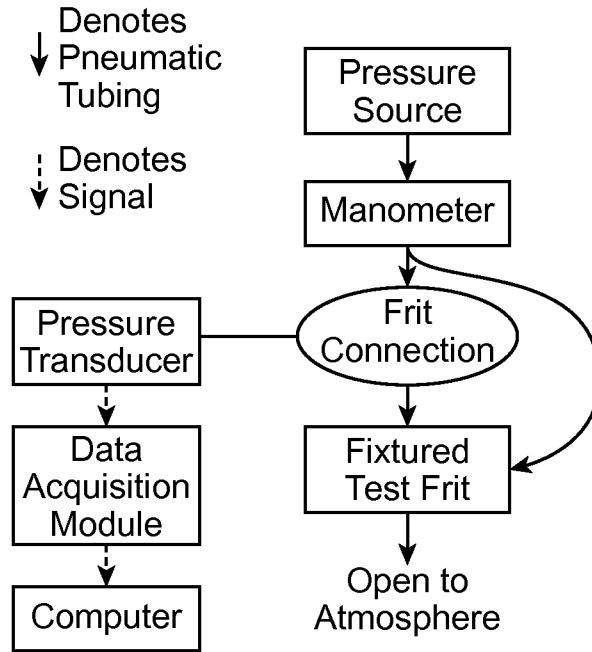

FIG. 28

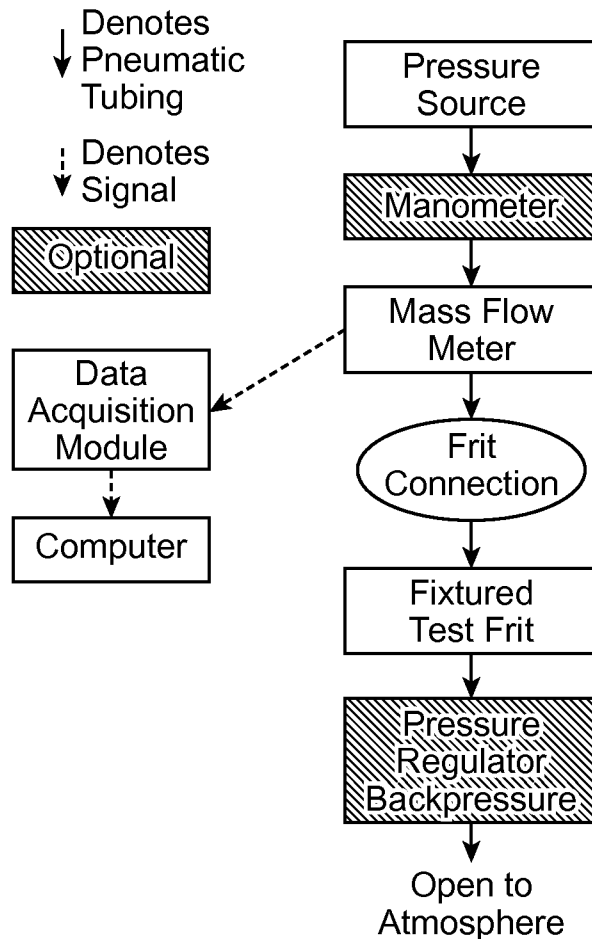

FIG. 29

INTERNATIONAL SEARCH REPORT

International application No.  
PCT/US 11/46817

**A. CLASSIFICATION OF SUBJECT MATTER**  
 IPC(8) - A61K 31/74 (2011.01)  
 USPC - 424/78.04-78.05  
 According to International Patent Classification (IPC) or to both national classification and IPC

**B. FIELDS SEARCHED**  
 Minimum documentation searched (classification system followed by classification symbols)  
 USPC -- 424/78.04-78.05

Documentation searched other than minimum documentation to the extent that such documents are included in the fields searched  
 USPC -- 424/400, 571; 435/7.23, 283.1 (see search terms below)

Electronic data base consulted during the international search (name of data base and, where practicable, search terms used)  
 PubWEST (USPT, PGPB, JPAB, EPAB); Google (search terms below)  
 (Eye OR ocular) (instrument OR device OR implant) membrane, COX, LOX, VEGF, vitreous humor

**C. DOCUMENTS CONSIDERED TO BE RELEVANT**

Category*	Citation of document, with indication, where appropriate, of the relevant passages	Relevant to claim No.
X — Y	US 2009/0074786 A1 (Dor et al.) 19 Mar 2009 (19.03.2009) entire document especially Abstract; para [0020], [0113], [0115]-[0117], [0411], [0489]	1-13 and 27-29 ----- 14-26 and 30-50
X ---- Y	US 2010/0189765 A1 (Erickson et al.) 29 Jul 2010 (29.07.2010) entire document especially Abstract; para [0052], [0083], [0088], [0129]-[0131], [0157]-[0159]	51 ----- 14-24 and 42-50
Y	US 2009/0306025 A1 (Lane) 10 Dec 2009 (10.12.2009) entire document especially Abstract; para [0009]-[0010]	25-26 and 30-41
Y	US 2009/0318545 A1 (Silver et al.) 24 Dec 2009 (24.12.2009) entire document especially para [0036], [0080]	34-41

Further documents are listed in the continuation of Box C.

\* Special categories of cited documents:

“A” document defining the general state of the art which is not considered to be of particular relevance	“T” later document published after the international filing date or priority date and not in conflict with the application but cited to understand the principle or theory underlying the invention
“E” earlier application or patent but published on or after the international filing date	“X” document of particular relevance; the claimed invention cannot be considered novel or cannot be considered to involve an inventive step when the document is taken alone
“L” document which may throw doubts on priority claim(s) or which is cited to establish the publication date of another citation or other special reason (as specified)	“Y” document of particular relevance; the claimed invention cannot be considered to involve an inventive step when the document is combined with one or more other such documents, such combination being obvious to a person skilled in the art
“O” document referring to an oral disclosure, use, exhibition or other means	“&” document member of the same patent family
“P” document published prior to the international filing date but later than the priority date claimed	

Date of the actual completion of the international search 15 Dec 2011 (15.12.2011)	Date of mailing of the international search report <b>22 DEC 2011</b>
---	--

Name and mailing address of the ISA/US Mail Stop PCT, Attn: ISA/US, Commissioner for Patents P.O. Box 1450, Alexandria, Virginia 22313-1450 Facsimile No. 571-273-3201	Authorized officer: Lee W. Young  PCT Helpdesk: 571-272-4300 PCT OSP: 571-272-7774
---	--

## INTERNATIONAL SEARCH REPORT

International application No.

PCT/US 11/46817

**Box No. II Observations where certain claims were found unsearchable (Continuation of item 2 of first sheet)**

This international search report has not been established in respect of certain claims under Article 17(2)(a) for the following reasons:

1.  Claims Nos.:  
because they relate to subject matter not required to be searched by this Authority, namely:
  
2.  Claims Nos.:  
because they relate to parts of the international application that do not comply with the prescribed requirements to such an extent that no meaningful international search can be carried out, specifically:
  
3.  Claims Nos.: 52-74  
because they are dependent claims and are not drafted in accordance with the second and third sentences of Rule 6.4(a).

**Box No. III Observations where unity of invention is lacking (Continuation of item 3 of first sheet)**

This International Searching Authority found multiple inventions in this international application, as follows:

1.  As all required additional search fees were timely paid by the applicant, this international search report covers all searchable claims.
2.  As all searchable claims could be searched without effort justifying additional fees, this Authority did not invite payment of additional fees.
3.  As only some of the required additional search fees were timely paid by the applicant, this international search report covers only those claims for which fees were paid, specifically claims Nos.:
  
4.  No required additional search fees were timely paid by the applicant. Consequently, this international search report is restricted to the invention first mentioned in the claims; it is covered by claims Nos.:

**Remark on Protest**

- The additional search fees were accompanied by the applicant's protest and, where applicable, the payment of a protest fee.
- The additional search fees were accompanied by the applicant's protest but the applicable protest fee was not paid within the time limit specified in the invitation.
- No protest accompanied the payment of additional search fees.