



US006027348A

United States Patent [19]

[11] **Patent Number:** **6,027,348**

Lai et al.

[45] **Date of Patent:** **Feb. 22, 2000**

[54] **GROUNDING PLATE FOR AN IC CARD CONNECTOR APPARATUS**

[56] **References Cited**

[75] Inventors: **Ming-Chuan Lai**, Hsin-Chuang;
Shun-Chi Tung, Tu-Chen, both of
Taiwan

U.S. PATENT DOCUMENTS

5,588,850 12/1996 Pan et al. 439/92
5,795,190 8/1998 Ono 439/607

[73] Assignee: **Hon Hai Precision Ind. Co., Ltd.**,
Taipei Hsien, Taiwan

Primary Examiner—Gary F. Paumen
Attorney, Agent, or Firm—Wei Te Chung

[21] Appl. No.: **09/337,863**

[57] **ABSTRACT**

[22] Filed: **Jun. 21, 1999**

An IC card connector apparatus mounted on a circuit board has a header connector with two arrays of conductive terminals extending therethrough. A grounding plate with a plurality of fingers integrally formed thereon is disposed on a bottom surface of the header connector for directly contacting a plurality of corresponding pads formed on the circuit board.

[30] Foreign Application Priority Data

Dec. 31, 1998 [TW] Taiwan 87222080

[51] **Int. Cl.⁷** **H01R 9/09**

[52] **U.S. Cl.** **439/92**

[58] **Field of Search** 439/92, 607, 101,
439/108, 64, 95, 946, 74

5 Claims, 4 Drawing Sheets

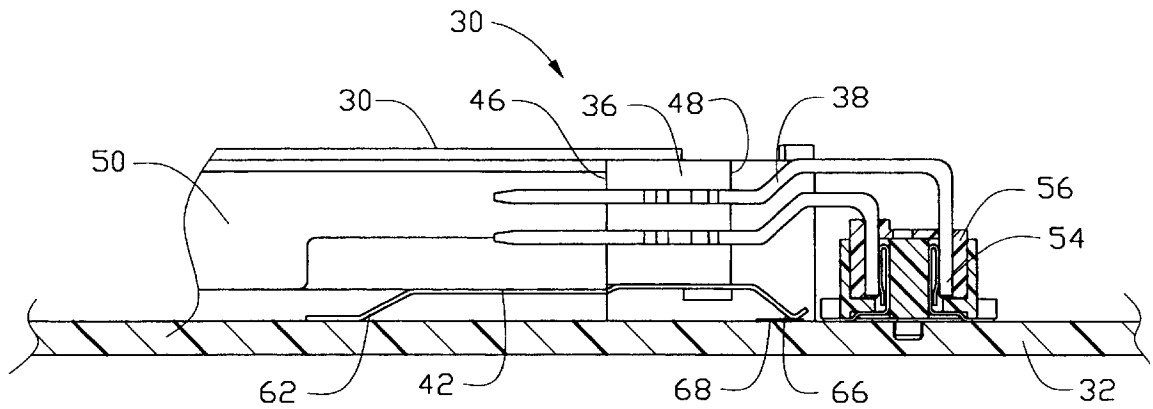

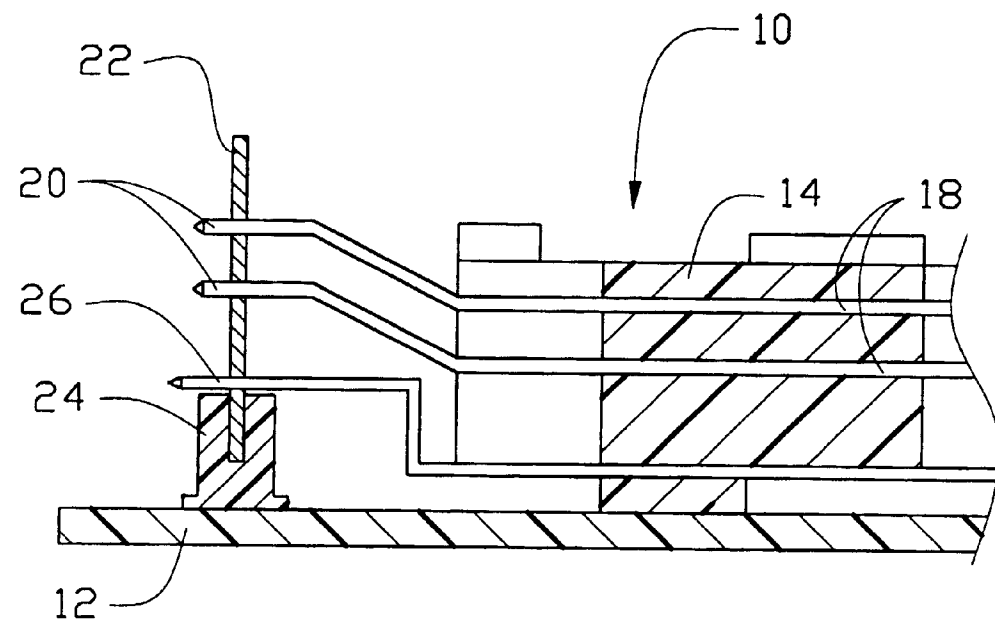

FIG.1
(PRIOR ART)

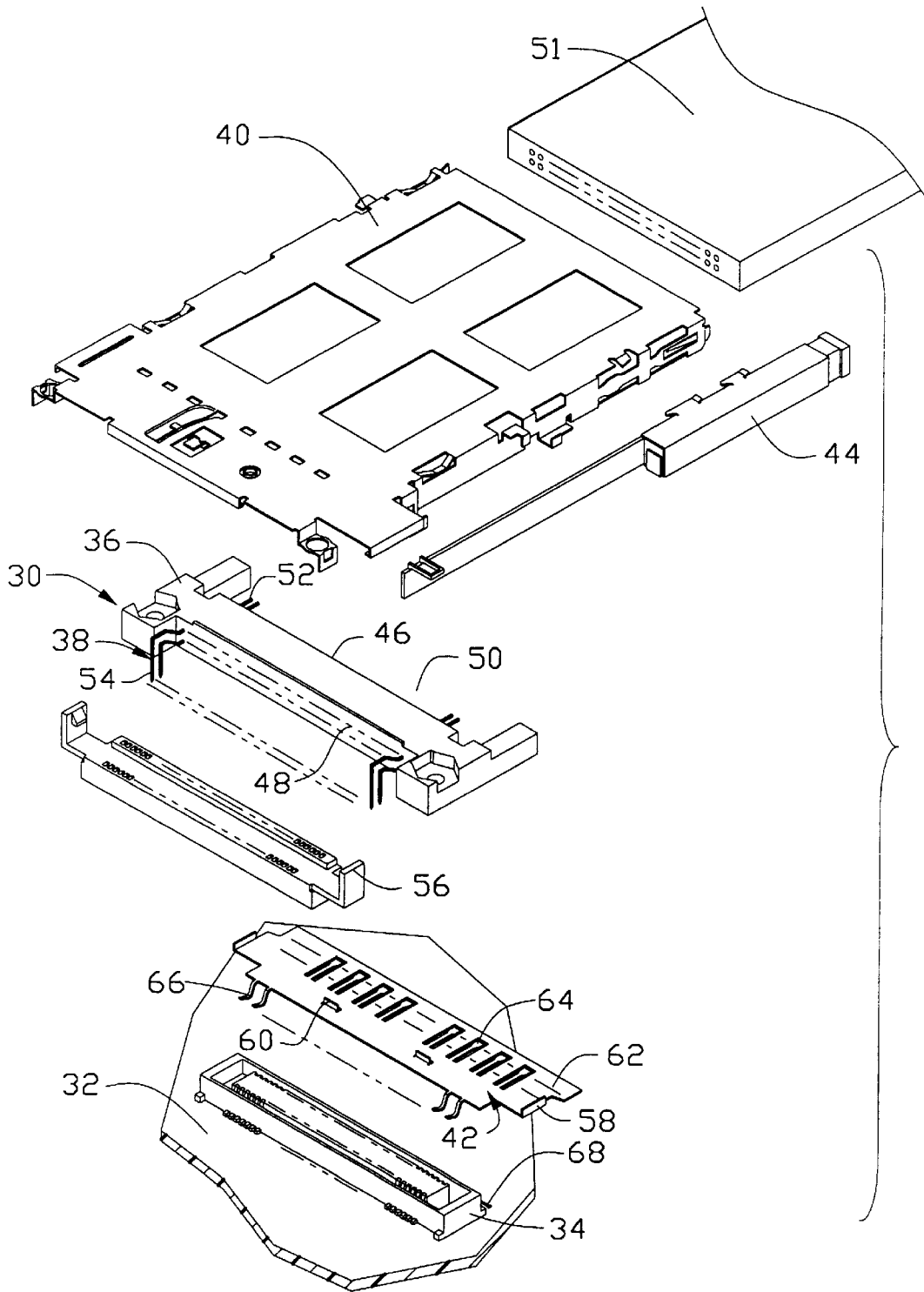

FIG.2

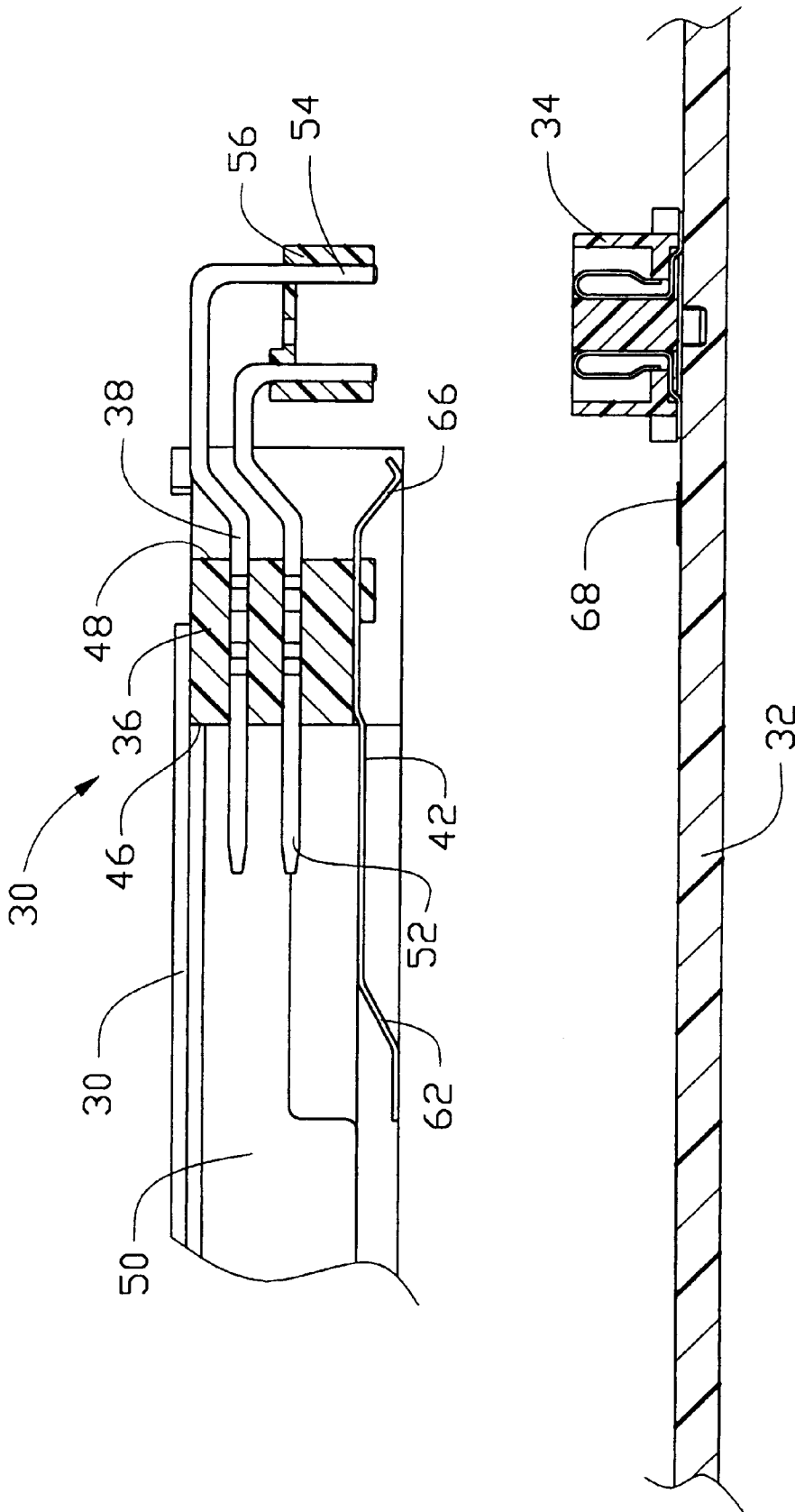

FIG.3

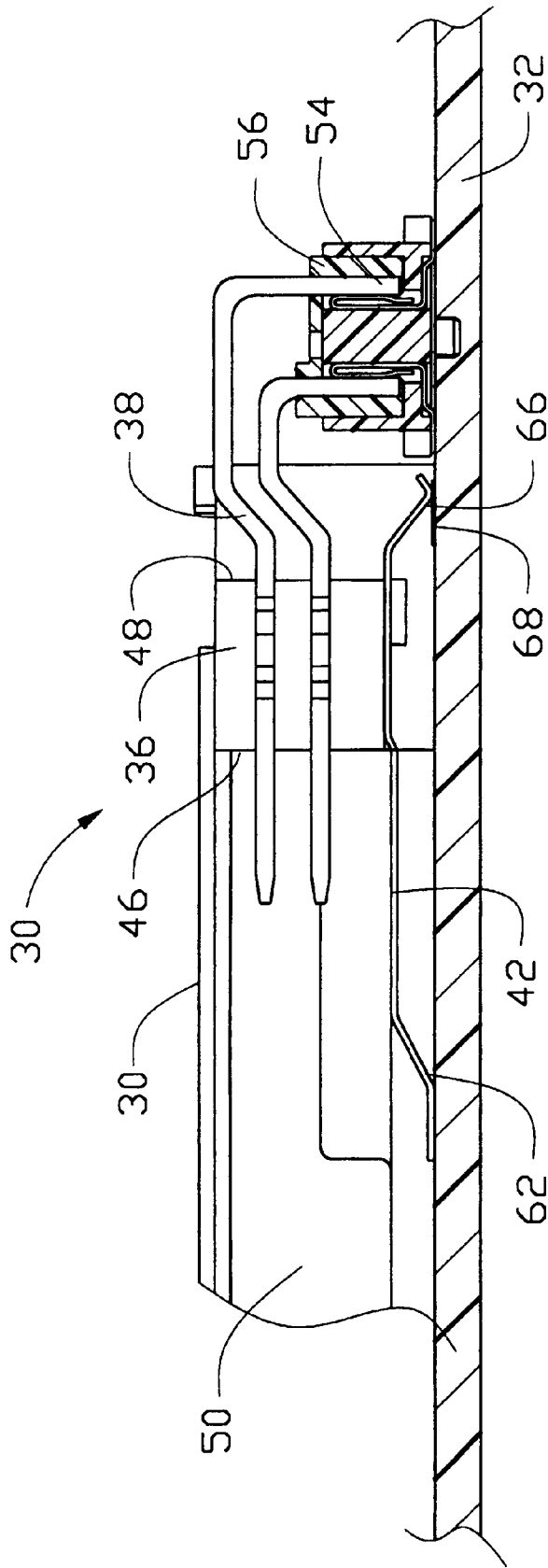

FIG.4

GROUNDING PLATE FOR AN IC CARD CONNECTOR APPARATUS

BACKGROUND OF THE INVENTION

The present invention relates to an IC card connector apparatus, and particularly to an IC card connector apparatus having a plurality of grounding fingers for directly contacting grounding pads of a circuit board.

DESCRIPTION OF PRIOR ART

Taiwan Patent Application No. 85216014 discloses a conventional header connector. As shown in FIG. 1, the conventional header connector **10** mounted on a first circuit board **12** includes an insulative housing **14** having two arrays of conductive terminals **18** assembled therein. Each terminal **18** has a mounting portion **20** outwardly and upwardly extending from the housing **14** and received in a second circuit board **22** which is connected to the first board **12** via a socket **24** on the first board **12**. In addition, a grounding plate (not labeled) is mounted to a side of the header connector **10** and integrally forming a plurality of grounding ends **26** substantially parallel to the terminals **18**. The grounding ends **26** are received in the second board **22**. The grounding ends **26** are connected with a grounding circuit (not shown) of the first board **12** via the socket.

Since both the terminals **18** and the grounding ends **26** are received in the second board **22**, the upwardly bent grounding ends **26** require the contact portions **20** of the terminals **18** to be engaged with the second board **22** at a higher level. Thus, an increase of occupied space within the computer enclosure results. Furthermore, the contact portions **20** of the terminals **18** and the grounding ends **26** are processed by a soldering procedure to be bonded with the second board **22**. Such a method is time and cost inefficient. In addition, the electrical path between the ends **26** of the grounding plate and the grounding circuit of the first board involves several components, thereby, further increasing the electrical resistance thereof.

SUMMARY OF THE INVENTION

Accordingly, the primary object of the present invention is to provide an IC card connector apparatus having a short grounding path which can quickly eliminate interference signals on the IC card during insertion of the IC card into the apparatus.

Another object of the present invention is to provide an IC card apparatus having grounding means which directly contacts a grounding circuit of a PC board.

A further object of the present invention is to provide an IC card connector apparatus with grounding means which has a simple structure and can be easily assembled.

Yet another object of the present invention is to provide an IC card connector apparatus having a limited height for promoting an efficient use of space within a computer enclosure.

To fulfill the above-mentioned objects, an IC card connector apparatus mounted on a circuit board comprises a header connector having an insulative housing with a plurality of terminals received therein and a grounding plate disposed on a bottom surface of the housing. The grounding plate integrally forms a plurality of tabs for contacting grounding portions formed on an IC card which is adapted to be inserted into the header connector. The grounding plate further forms a plurality of fingers downwardly bent for directly contacting grounding pads of the circuit board.

Therefore, interference signals on the IC card can be quickly eliminated thereby ensuring proper signal transmission between the IC card and the header connector.

Other objects, advantages and novel features of the invention will become more apparent from the following detailed description when taken in conjunction with the accompanying drawings.

BRIEF DESCRIPTION OF THE DRAWINGS

FIG. 1 is a partial, cross-sectional view of a conventional header connector for connecting an IC card;

FIG. 2 is an exploded view of an IC card connector apparatus in accordance with the present invention;

FIG. 3 is a partial cross-sectional view of the IC card connector apparatus of the present invention before assembly to a printed circuit board; and

FIG. 4 is similar to FIG. 3 wherein the IC card apparatus assembled to the printed circuit board.

DETAILED DESCRIPTION OF A PREFERRED EMBODIMENT

Referring to FIGS. 2 and 3, an IC card connector apparatus connected to a circuit board **32** by means of a socket **34** mounted thereon, has a header connector **30**, a shielding plate **40**, an elongate grounding plate **42** and an ejector mechanism **44**. The header connector **30** includes an insulative housing **36** defining a front surface **48**, a rear surface **46**, and a space **50** adjacent to the rear surface **46** for receiving an IC card **51** therein. A plurality of conductive terminals **38** having mating ends **52** and mounting ends **54** is received in an array of passageways defined between the front surface **48** and the rear surface **46** of the housing **36**. The mating ends **52** extend into the space **50** for engaging the IC card **51**. The mounting ends **38** extend beyond the rear surface **48** of the housing **36** and are received in an elongate portion **56** which is mated with the socket **34** mounted on. The shielding plate **40** is disposed on a top surface of the housing **36**.

The grounding plate **42** is disposed on a bottom surface of the housing **36**. The grounding plate **42** includes a pair of bent portions **58** formed at opposite ends thereof and a pair of ribs **60** defined between the bent portions **58**. The bent portions **58** and the ribs **60** are adapted to secure the grounding plate **42** to the bottom surface of housing **36**. In addition, the grounding plate **42** forms a slanted leading edge **62** for facilitating insertion of the IC card **51** into the header connector **30**. Furthermore, a plurality of tabs **64** is integrally formed on the leading edge **62** of the grounding plate **42** for contacting corresponding grounding portions (not shown) formed on the IC card **51**. A plurality of spring fingers **66** is integrally formed on an edge of the grounding plate **42** opposite the leading edge **62**. The spring fingers **66** are bent to contact the circuit board **32**.

Also referring to FIG. 4, when assembled, the spring fingers **66** of the grounding plate **42** directly contact corresponding grounding pads **68** formed on the circuit board **32**. When the IC card **51** is inserted into the space **50** of the header connector **30**, the grounding portions formed on the IC card **51** contact the corresponding tabs **64** of the grounding plate **42**. Thus, interference signals on the IC card **51** are eliminated through the spring fingers **66** of the grounding plate **42** and the grounding pads **68** of the circuit board **32**.

It is readily apparent that such a short grounding path can quickly eliminate interference signals on the IC card **51** to ensure proper and reliable signal transmission between the

3

IC card 51 and the header connector 30. The grounding plate 42 has a simple structure and can be easily assembled. In addition, the direct contact between the spring fingers 66 of the grounding plate 42 and the grounding pads 68 of the circuit board 32 effectively eliminates the requirement of the specific arrangement of the grounding means of the prior art. Thus, the height of the apparatus is reduced thereby promoting an efficient use of space within a computer enclosure. The tabs 64 of the grounding plate 42 may be soldered to the circuit board 32 for more reliably connecting with a grounding circuit thereof.

It is to be understood, however, that even though numerous characteristics and advantages of the present invention have been set forth in the foregoing description, together with details of the structure and function of the invention, the disclosure is illustrative only, and changes may be made in detail, especially in matters of shape, size, and arrangement of parts within the principles of the invention to the full extent indicated by the broad general meaning of the terms in which the appended claims are expressed.

What is claimed is:

1. An electrical connector apparatus mounted on a circuit board for receiving an IC card, comprising:

- a header connector having an insulative housing and two arrays of terminals extending through the insulative housing; and
- a grounding plate disposed on one side of the header connector proximate to the circuit board, the grounding plate having a plurality of fingers for directly contacting corresponding pads on the circuit board;

wherein said grounding plate is secured to and extends along a bottom surface of the housing between the housing and the circuit board.

4

2. The electrical connector apparatus as claimed in claim 1, wherein said fingers are integrally formed on the grounding plate.

3. The electrical connector apparatus as claimed in claim 1, wherein said grounding plate comprises a slanted leading edge for guiding insertion of the IC card.

4. The electrical connector apparatus as claimed in claim 3, wherein a plurality of tabs is formed on said leading edge for contacting an IC card grounding portion.

5. A connector assembly comprising:

a header having an insulative housing with two arrays of terminals extending through said housing, each of said terminals including a downward extending mounting end;

a grounding plate positioned on the header with a plurality of fingers thereof;

an elongated portion attached to the housing and receiving the mounting end of each of the terminals therein;

a circuit board, on which the header is mounted, including a plurality of grounding pads thereon; and

a socket mounted on said circuit board; wherein said grounding pads and said fingers are arranged to directly contact each other when the elongated portion with the mounting ends of the terminals is fully mated with the socket;

wherein said grounding plate is secured to and extends along a bottom surface of the housing between the housing and the circuit board.

* * * * *