



INTERNATIONAL APPLICATION PUBLISHED UNDER THE PATENT COOPERATION TREATY (PCT)

(51) International Patent Classification ⁶ : G06F 1/16	A1	(11) International Publication Number: WO 97/04380 (43) International Publication Date: 6 February 1997 (06.02.97)
(21) International Application Number: PCT/US96/12352 (22) International Filing Date: 24 July 1996 (24.07.96) (30) Priority Data: 08/506,095 24 July 1995 (24.07.95) US (71) Applicant: KHYBER TECHNOLOGIES CORPORATION [US/US]; Building 350, 150 North Miller Road, Fairlawn, OH 44333-3713 (US). (72) Inventors: KUMAR, Rajendra; 712 Stonecliff Drive, Akron, OH 44313 (US). BROOKS, Steven, E.; 2838 - 25th Street Southeast, Canton Township, OH 44707 (US). (74) Agent: ROBBINS, Howard, S.; Khyber Technologies Corpo- ration, Building 350, 150 North Miller Road, Fairlawn, OH 44333-3713 (US).		(81) Designated States: AU, CA, CN, JP, European patent (AT, BE, CH, DE, DK, ES, FI, FR, GB, GR, IE, IT, LU, MC, NL, PT, SE). Published <i>With international search report.</i>

(54) Title: SELECTIVELY ATTACHABLE KEYBOARD BRACKET AND LOCKABLE HOLDER FOR A HANDHELD COMPUTER

(57) Abstract

A device (10) adding keyboard input to a handheld computer (12) lacking such input (such as pen computers and personal digital assistants) includes a bracket (30) removably carrying the handheld computer (12), and a joint (40) secured to the keyboard (11) and the bracket (30) for positioning the keyboard (11) in a plurality of orientations relative to the handheld computer (12). These orientations include a first orientation in which the keyboard (11) is operable and at a pre-selected viewing angle from a display (14) that is part of the handheld computer (12), a second orientation adjacent the display (14) in which the keyboard (11) substantially covers the display (14), and a third orientation proximate the handheld computer (12) in which the display (14) is unobstructed, thereby facilitating pen-based input through the display (14). A locking slide (52) carried in a recess (51) is selectively extended by the user to pass through a plurality of slots (53, 54 and 55) in joint (40) to secure the keyboard (11) and handheld computer (12) in the first and operational orientation.

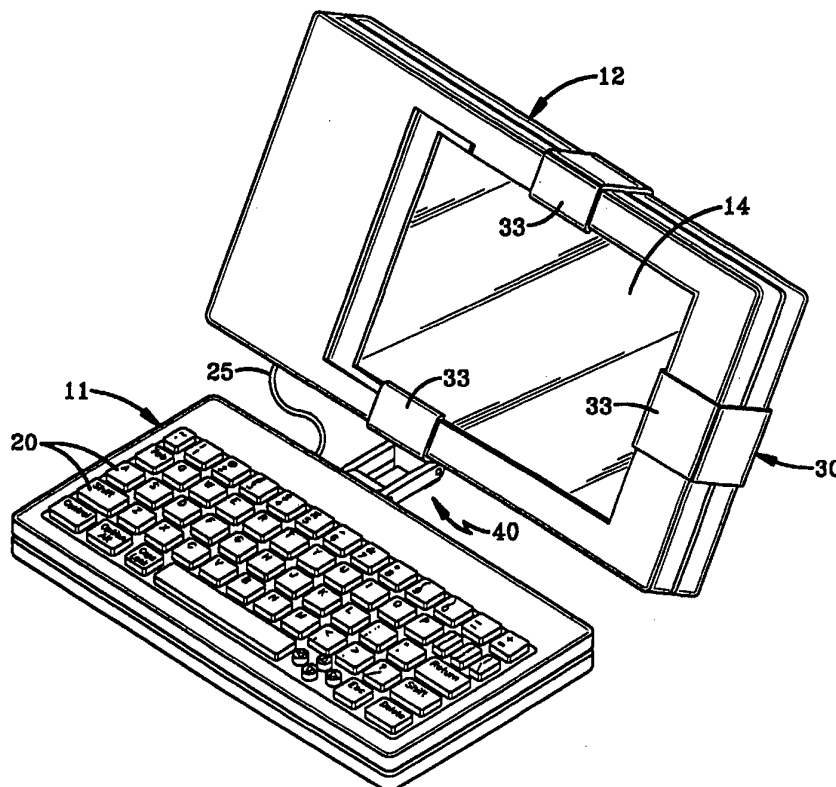

FOR THE PURPOSES OF INFORMATION ONLY

Codes used to identify States party to the PCT on the front pages of pamphlets publishing international applications under the PCT.

AM	Armenia	GB	United Kingdom	MW	Malawi
AT	Austria	GE	Georgia	MX	Mexico
AU	Australia	GN	Guinea	NE	Niger
BB	Barbados	GR	Greece	NL	Netherlands
BE	Belgium	HU	Hungary	NO	Norway
BF	Burkina Faso	IE	Ireland	NZ	New Zealand
BG	Bulgaria	IT	Italy	PL	Poland
BJ	Benin	JP	Japan	PT	Portugal
BR	Brazil	KE	Kenya	RO	Romania
BY	Belarus	KG	Kyrgystan	RU	Russian Federation
CA	Canada	KP	Democratic People's Republic of Korea	SD	Sudan
CF	Central African Republic	KR	Republic of Korea	SE	Sweden
CG	Congo	KZ	Kazakhstan	SG	Singapore
CH	Switzerland	LI	Liechtenstein	SI	Slovenia
CI	Côte d'Ivoire	LK	Sri Lanka	SK	Slovakia
CM	Cameroon	LR	Liberia	SN	Senegal
CN	China	LT	Lithuania	SZ	Swaziland
CS	Czechoslovakia	LU	Luxembourg	TD	Chad
CZ	Czech Republic	LV	Latvia	TG	Togo
DE	Germany	MC	Monaco	TJ	Tajikistan
DK	Denmark	MD	Republic of Moldova	TT	Trinidad and Tobago
EE	Estonia	MG	Madagascar	UA	Ukraine
ES	Spain	ML	Mali	UG	Uganda
FI	Finland	MN	Mongolia	US	United States of America
FR	France	MR	Mauritania	UZ	Uzbekistan
GA	Gabon			VN	Viet Nam

SELECTIVELY ATTACHABLE KEYBOARD BRACKET AND LOCKABLE HOLDER FOR A HANDHELD COMPUTER

5

TECHNICAL FIELD

The present invention relates in general to processor based devices operable while being held in its user's hand, such as a handheld computer. More particularly, the present invention pertains to handheld computing devices lacking one or more type of input mechanism. More specifically, the present invention relates to handheld computing devices such as a handheld pen computer or personal digital assistant which omit a keyboard. Still more specifically, the present invention involves devices allowing a user of a keyboardless handheld computer to selectively attach a keyboard thereto and operate the keyboard while viewing the computer display at an angle to the plane of the keyboard.

15

BACKGROUND ART

Portable computing and communication devices are quickly becoming ubiquitous tools for both business and personal activities. The smallest and lightest of these devices are suitable for and most often carried and operated while being held in the hand of its user. Typical of these devices are the variety of so-called pen computers and personal digital assistants (PDAs) now commercially available. Whereas historically user input to computing and communication devices has been primarily through a keyboard, pen computers and PDAs have eliminated the keyboard, not only because its size and weight often make it inconvenient and impracticable to carry and use, but also because many mobile tasks require a more limited extent of textual input. As experience with these devices has increased, however, it has been recognized that from time to time nearly all applications and users would benefit from the ability to perform keyboard input.

Efforts have been made to provide both portable computers and pen computers in a single housing. These efforts have all involved repositioning the display of a laptop computer so that it covers and hides the keyboard, typically in the manner of a tablet. Exemplary of these efforts are the laptop computers shown in U.S. Patent

30

Numbers 5,276,589 and 5,268,816 in which the display is mounted to slide or pivot in three-dimensions over the keyboard; the laptop computer shown in U.S. Patent No. 5,241,303 in which the display and keyboard detach and are repositioned with the display lying flat and the keyboard stored in a compartment under the display; and the
5 ThinkPad Model 750P laptop computer manufactured by International Business Machines Corporation of White Plains, New York in which the display is carried on an articulated arm which moves in three-dimensions to allow the display to be repositioned directly over the keyboard.

No matter what the approach, such efforts invariably produce units that are
10 large, heavy, expensive, complex and difficult and cumbersome to transform from keyboard input to keyboardless operation. Moreover, these efforts do not adapt to pen computers and PDAs currently in use, and are not suitable for operation while being carried in the hand of a user in motion.

Some pen computers and PDAs presently commercially available do include a
15 socket to connect to the cable from a conventional keyboard. However, given the inconvenience of carrying, connecting and operating a completely external keyboard, existing pen computer and PDA users almost universally elect to go without keyboard input even in those relative frequently occurring situations in which it would be beneficial. In those situations where a keyboard is cabled to a pen computer or PDA,
20 the user is forced to either position the pen computer or PDA display in the same plane as the keyboard, causing significant input viewing difficulties and stress, or seek another object with which to prop up the pen computer or PDA display, at best an unstable, make-shift configuration subject to collapse.

In short, heretofore no handheld computer possessed an orientation facilitating
25 keyboard-based input when the device is simultaneously handheld and mobile, another orientation facilitating pen-based input when the device is simultaneously handheld and mobile, and a nonoperational orientation.

SUMMARY OF THE INVENTION

30 It is, therefore, an object of the present invention to provide a device that furnishes a handheld computer with an orientation facilitating keyboard-based input when the handheld computer is operated simultaneously handheld and mobile, another orientation facilitating pen-based input when the handheld computer is operated

simultaneously handheld and mobile, and a nonoperational orientation.

It is another object of the present invention to provide a device, as set forth above, that permits the inclusion of a keyboard with a keyboardless handheld computer.

5 It is still another object of the present invention to provide a device, as set forth above, which is simple to move from an operational to a nonoperational position.

It is yet another object of the present invention to provide a device, as set forth above, that is as compact as the handheld computer, inexpensive to manufacture and uncomplicated.

10 It is a further object of the present invention to provide a device, as set forth above, that may be removably added by the user to existing and new handheld computers.

It is still a further object of the present invention to provide a device, as set forth above, that allows the user to position the keyboard at an angle to the computer display, facilitating comfortable viewing during keyboard input.

15 It is yet a further object of the present invention to provide a device, as set forth above, that allows the user to lockable secure the keyboard and the computer at the aforesaid viewing angle and insures the device does not collapse or tip over when so secured.

20 These and other objects and advantages of the present invention over existing prior art forms will become more apparent and fully understood from the following description in conjunction with the accompanying drawings.

In general, a device in accordance with the present invention selectively attaches a keyboard to a handheld apparatus having a display, and includes a bracket for
25 removably carrying the handheld apparatus, the bracket releasably secured to the handheld apparatus at a plurality of locations, and a joint secured to the keyboard and the bracket for positioning the keyboard in a plurality of orientations relative to the display. These orientations include a first orientation in which the keyboard is operable and at a preselected viewing angle from the display, a second orientation adjacent
30 the display in which the keyboard substantially covers the display, and a third orientation proximate the handheld apparatus in which the display is unobstructed.

In general, another device in accordance with the present invention includes a handheld apparatus having a display, a first input to the handheld apparatus, and a

joint secured to the handheld apparatus and the first input for positioning the first input in a plurality of orientations relative to the display. These orientations including a first orientation in which the first input is operable and at a preselected viewing angle from the display, a second orientation adjacent the display in which the first input substantially covers the display, and a third orientation proximate the handheld apparatus in which the display is unobstructed.

BRIEF DESCRIPTION OF THE DRAWINGS

Fig. 1 is a top plan view of an exemplary device in accordance with the present invention in an operational orientation, depicting a selectively attachable keyboard socket clipped to a handheld computer and carrying a keyboard.

Fig. 2 is a bottom plan view of the exemplary device shown in Fig. 1 in the same orientation as depicted in Fig. 1.

Fig. 3 is a top plan view of the exemplary device shown in Fig. 1 in which the keyboard has been rotated about its top-to-bottom axis 90° from the plane of the handheld computer.

Fig. 4 is a side elevation of the exemplary device shown in Fig. 1 in the same orientation depicted in Fig. 1.

Fig. 5 is a side elevation of the exemplary device shown in Fig. 1 in a closed orientation in which the keyboard is folded over the handheld computer display with the keyboard keys facing the display.

Fig. 6 is a side elevation of the exemplary device shown in Fig. 1 in a pen-based data entry orientation in which the keyboard is folded behind the back of the handheld computer with the keyboard keys facing the back of the handheld computer.

Fig. 7 is a side elevation of the exemplary device shown in Fig. 1 in a keyboard-based data entry orientation in which the keyboard is positioned at a preselected viewing angle relative to the handheld computer display, similar to that of a small notebook-style computer, enabling both keyboard-based and pen-based data entry.

Fig. 8 is a bottom plan view of the exemplary device shown in Fig. 1 in the keyboard-based data entry orientation depicted in Fig. 7.

Fig. 9 is a side elevation as shown in Fig. 7 in which a portion of the keyboard, the exemplary device, and a portion of the handheld computer are all illustrated in

partial sectional form taken substantially along the line 9—9 of Fig. 1, presenting the display support mechanism in its locked, operational orientation.

Fig. 10 is a perspective view of the exemplary device shown in Fig. 1.

Fig. 11 is a perspective view of the exemplary device shown in Fig. 1 in the
5 orientation depicted in Figs. 7 and 9.

PREFERRED EMBODIMENT FOR CARRYING OUT THE INVENTION

Fig. 10 presents a perspective view of an exemplary device in accordance with the present invention, generally indicated by the numeral 10, for providing a keyboard
10 input apparatus 11 to a handheld computer 12 or other apparatus, such as a pen computer or a personal digital assistant (PDA). Handheld computer 12 includes a display 14 carried within a housing 15 possessing a plurality of sides 16, best seen in the top and bottom plan views of Figs. 1 and 2, respectively. Device 10 broadly includes a bracket 30 for removably carrying a handheld computer 12 as further detailed herein-
15 after, a joint 40 for allowing the relative positioning and orientation described below between handheld computer 12 and keyboard input apparatus 11 secured thereto, and a locking mechanism 50 for fixing an angular relationship between keyboard input apparatus 11 and handheld computer 12 (and, more specifically, its display 14).

Keyboard input apparatus 11 (hereinafter keyboard 11) secured to device 10
20 includes a plurality of keys 20 carried within a keyboard housing 21 having a front 22 through which the keys extend, a back 23, and four sides 24. A cable 25 including multiple electrical power and data conductors extends between and electrically interconnects keyboard 11 and handheld computer 12. Keyboard 11 is preferably no larger in area than that of handheld computer 12 and is as thin and light as possible.
25 Nevertheless, the skilled artisan will appreciate the desirability of employing a keyboard 11 with an acceptable balance of size, weight and tactile operating characteristics.

Bracket 30 removably carries handheld computer 12, and includes a beam 31 from which extend a plurality of arms 32. The distal end of each arm 32 is formed,
30 preferably integrally, into a clip 33 for releasably securing bracket 30 to handheld computer 12 at a plurality of locations by releasably grasping a suitable plurality of the sides 16 of handheld computer 12. Beam 31, arms 32 and clips 33 are preferably positioned so as to engage sides 16 at locations that do not interfere with access to

controls and electrical connections extending through housing 15.

Joint 40 includes a parallel linkage 41 having two swing arms 42, 43 rotatable about a pivot pin 44 with longitudinal axis 44' at one end of parallel linkage 41, and a pivot pin 45 with longitudinal axis 45' at the opposite end of parallel linkage 41.

5 Joint 40 further includes a substantially rectangular block-shaped bracket anchor 46 fixed to and preferably integrally formed with bracket 30, and a substantially rectangular block-shaped keyboard anchor 48. Bracket anchor 46 spaces apart swing arms 42, 43 at the end of parallel linkage 41 that adjoins bracket 30 and rotates about pivot pin 44. Keyboard anchor 48 spaces apart swing arms 42, 43 at the end of parallel
10 linkage 41 that adjoins keyboard 11 and rotates about pivot pin 45. The skilled artisan will appreciate that configured in this manner joint 40 allows any object affixed to the side of keyboard anchor 48 furthest from bracket 30 to be swung both in front of bracket 30 and behind bracket 30.

Keyboard anchor 48 includes a mechanism for securing keyboard 11 thereto in
15 such manner as to allow its rotation about an axis perpendicular to axes 44' and 45', such as split anchor pin 49 having longitudinal axis 49'. Split anchor pin 49 is substantially cylindrically-shaped with a mushroom head to engage a mating bore 26 (Fig. 10) in the rear side of keyboard 11, allowing rotation of keyboard 11 about axis 49'.

20 Joint 40 permits and facilitates a plurality of relative positions between keyboard 11 and device 10, and more particularly display 14. In what may be arbitrarily referred to as a first and operational orientation, best depicted in the perspective view of device 10 in Fig. 11, the side and bottom views of Figs. 7 and 8, respectively, and the partial side view/partial sectional view of Fig. 9 taken substantially along the line
25 9—9 of Fig. 1, keyboard 11 is operable and at a comfortable, preselected viewing angle from display 14, much like that of a notebook computer. In what may be arbitrarily referred to as a second orientation, keyboard 11 substantially covers display 14, preferably with keys 20 facing display 14, as illustrated in Fig. 5, to preclude their inadvertent engagement. In what may be arbitrarily referred to as a third and
30 operational orientation, keyboard 11 is positioned adjacent the back 23 of handheld apparatus 12, preferably with keys 20 facing back 23, as shown in Fig. 6, to preclude their inadvertent engagement.

Changing the relative positioning and orientation between keyboard 11, on the

one hand, and handheld computer 12 and its display 14, on the other hand, involves straightforward motion of joint 40 that may be explained beginning with keyboard 11 and handheld computer 12 in substantially the same plane, as depicted in the side elevation of Fig. 4 and the top and bottom plan views of Figs. 1 and 2, respectively.

5 The first and operational orientation is achieved by simply rotating bracket 30 about pivot pin 44 and its longitudinal axis 44' in the direction that brings display 14 closer to keys 20, as presented in the perspective view of Fig. 11, the side elevations of Fig. 7 and 9, and the bottom plan view of Fig. 8.

10 The second orientation may be realized from the planar position of Fig. 4 by rotating bracket 30 about both pivot pins 44 and 45 and their respective longitudinal axes 44' and 45' in the direction that folds keyboard 11 over display 14, as shown in Fig. 5, preferably with keys 20 facing display 14 so that keyboard 11 may act as a protective cover thereto in this nonoperational configuration.

15 The third orientation may be reached from the planar position of Fig. 4 by first twisting keyboard 11 (as simulated in Fig. 3) one hundred eighty degrees about anchor pin 49 until keys 20 are facing downward, and then rotating bracket 30 about both pivot pins 44 and 45 and their respective longitudinal axes 44' and 45' in the direction that folds keyboard 11 behind handheld computer 12, as shown in Fig. 6. In this pen-based entry operational configuration keyboard 11 is folded behind back 23
20 so as to permit complete and unobstructed access to display 14, and prevent the inadvertent pressing of keys 20.

25 Locking mechanism 50, which maintains display 14 in the preselected viewing orientation with respect to keyboard 11, includes a locking slide 51 slidably carried in a recess 52 in the back 23 of keyboard housing 21, and a plurality of slots 53, 54 and 55 through which locking slide 51 may be selectively slidably inserted and removed, as collectively illustrated in Figs. 2 and 7 through 10. Recess 52 is preferably integrally formed into the rear of keyboard housing 14, is substantially rectangular to correspond in geometry to locking slide 51, and has two guide rails 57, 58 disposed along either edge of recess 52 to engage long edges of locking slide 51 and let
30 locking slide 51 slide therealong. Recess 52 is positioned such that as locking slide 51 is pushed toward handheld computer 12 as by a user's finger applied to a raised finger pad 59 formed at the end of locking slide 51 most distant from handheld computer 12, locking slide 51 enters and passes through slot 53 in keyboard anchor

48, and slots 54 and 55 in the front and rear, respectively, of bracket anchor 46 until at its furthest extended position, shown in Figs. 7 through 9, locking slide 51 extends slightly past the rear of bracket anchor 46. When fully withdrawn into recess 52, as best seen in Fig. 2, locking slide 51 is carried entirely within keyboard housing 21.

5 It should now be apparent that once the user has placed keyboard 11 and handheld computer 12 in the first and operational orientation, the user pushes locking slide 51 to its furthest extended position, precluding both rotation of keyboard 11 about keyboard anchor pin 49 and movement of joint 40. Conversely, when the user wishes to configure keyboard 11 and handheld computer 12 in its nonoperational second
10 orientation or pen-based input third orientation, locking slide 51 is first fully retracted into keyboard housing 21. Further, whenever keyboard 11 is positioned atop a planar surface as a palmtop or desktop, the end of locking slide 51 extending past the rear of bracket anchor 46 functions as a retractable fulcrum acting against the planar surface, precluding tipping due to the greater weight of the elevated handheld computer 12.

15 Other modifications within the spirit of the present invention now should be evident to the skilled artisan. For example, for additional support of handheld computer 12, a selectively collapsible leg (not shown) may be included in the rear of bracket 30. Also, the present invention may be employed with any input device omitted from the handheld computer.

20 Inasmuch as the present invention is subject to variations, modifications and changes in detail, some of which have been expressly stated herein, it is intended that all matter described throughout this entire specification or shown in the accompanying drawings be interpreted as illustrative and not in a limiting sense. It should thus be evident that a device constructed according to the concept of the present invention,
25 and reasonably equivalent thereto, will accomplish the objects of the present invention and otherwise substantially improve the art of adding omitted functionality to handheld computing devices and, more particularly, adding keyboards to pen computers and PDAs.

CLAIMS:

- 1 1. A device for selectively attaching a keyboard to a handheld apparatus
2 having a display, comprising:
5 3 a bracket for removably carrying the handheld apparatus, said bracket
4 releasably secured to the handheld apparatus at a plurality of locations; and,
5 a joint secured to the keyboard and said bracket for positioning the
6 keyboard in a plurality of orientations relative to the display including a first
7 orientation in which the keyboard is operable and at a preselected viewing angle
10 8 from the display, a second orientation adjacent the display in which the keyboard
9 substantially covers the display, and a third orientation proximate the handheld
10 apparatus in which the display is unobstructed.
- 1 2. A device, as set forth in claim 1, wherein said joint includes a parallel
15 2 linkage defined by two swing arms rotatable about a pivot pin at both ends of
3 said swing arms, said swing arms spaced apart at one end by a first anchor fixed
4 to said bracket and spaced apart at the opposite end by a second anchor pivotally
5 secured to the keyboard.
- 20 1 3. A device, as set forth in claim 2, wherein said second anchor has a longi-
2 tudinal axis about which it rotates and is coaxial with one of said pivot pins, and
3 said second anchor includes an anchor pin extending perpendicular from said
4 longitudinal axis of said second anchor, the keyboard rotatable about said anchor
5 pin.
- 25 1 4. A device, as set forth in claim 3, further including a locking mechanism
2 whereby the keyboard and display are fixedly secured in said first orientation.
- 1 5. A device, as set forth in claim 4, wherein said locking mechanism includes
30 2 a first slot in said first anchor and a second slot in said second anchor in
3 substantial alignment with said first slot when the keyboard and the display are in
4 said first orientation, and a locking slide selectively extendable through said first
5 slot and said second slot.

1 6. A device, as set forth in claim 5, wherein the keyboard has a housing with
2 a front and a back and a plurality of keys extend from said housing front, and
3 wherein said locking slide is seated between two guide rails in said housing back
4 for selective extension into and retraction from said first slot and said second slot
5 5 when the keyboard and the display are in said first orientation.

1 7. A device, as set forth in claim 5, wherein said locking slide is selectively
2 extendable beyond said second anchor thereby effecting a retractable fulcrum.

10 1 8. A device, as set forth in claim 1, wherein the handheld apparatus has a
2 housing with plurality of sides, said bracket including a plurality of clips for
3 releasably grasping a plurality of said handheld apparatus housing sides at
4 locations noninterfering with operational features of the handheld apparatus.

15 1 9. A device, as set forth in claim 1, wherein said handheld apparatus is one
2 of a pen computer and personal digital assistant.

1 10. A device comprising: a handheld apparatus having a display; a first input
2 to said handheld apparatus; and, a joint secured to said handheld apparatus and
20 3 said first input for positioning said first input in a plurality of orientations relative
4 to said display including a first orientation in which said first input is operable
5 and at a preselected viewing angle from said display, a second orientation
6 adjacent said display in which said first input substantially covers said display,
7 and a third orientation proximate said handheld apparatus in which said display is
25 8 unobstructed.

1 11. A device, as set forth in claim 10, wherein said first input is a keyboard.

1 12. A device, as set forth in claim 11, wherein said joint includes a parallel
30 2 linkage defined by two swing arms rotatable about a pivot pin at both ends of
3 said swing arms, said swing arms spaced apart at one end by a first anchor fixed
4 to said handheld apparatus and spaced apart at the opposite end by a second
5 anchor pivotally secured to said keyboard.

1 13. A device, as set forth in claim 12, wherein said second anchor has a longi-
2 tudinal axis about which it rotates and is coaxial with one of said pivot pins, and
3 said second anchor includes an anchor pin extending perpendicular from said
4 longitudinal axis of said second anchor, said keyboard rotatable about said anchor
5 5 pin.

1 14. A device, as set forth in claim 13, further including a locking mechanism
2 whereby said keyboard and said display are fixedly secured in said first
3 orientation.

10

1 15. A device, as set forth in claim 14, wherein said locking mechanism
2 includes a first slot in said first anchor and a second slot in said second anchor in
3 substantial alignment with said first slot when said keyboard and said display are
4 in said first orientation, and a locking slide selectively extendable through said
15 5 first slot and said second slot.

1 16. A device, as set forth in claim 15, wherein said keyboard has a housing
2 with a front and a back and a plurality of keys extend from said housing front,
3 and wherein said locking slide is seated between two guide rails in said housing
20 4 back for selective extension into and retraction from said first slot and said
5 second slot when said keyboard and said display are in said first orientation.

1 17. A device, as set forth in claim 15, wherein said locking slide is selectively
2 extendable beyond said second anchor thereby effecting a retractable fulcrum.

25

1 18. A device, as set forth in claim 10, wherein said handheld apparatus is one
2 of a pen computer and personal digital assistant.

1/8

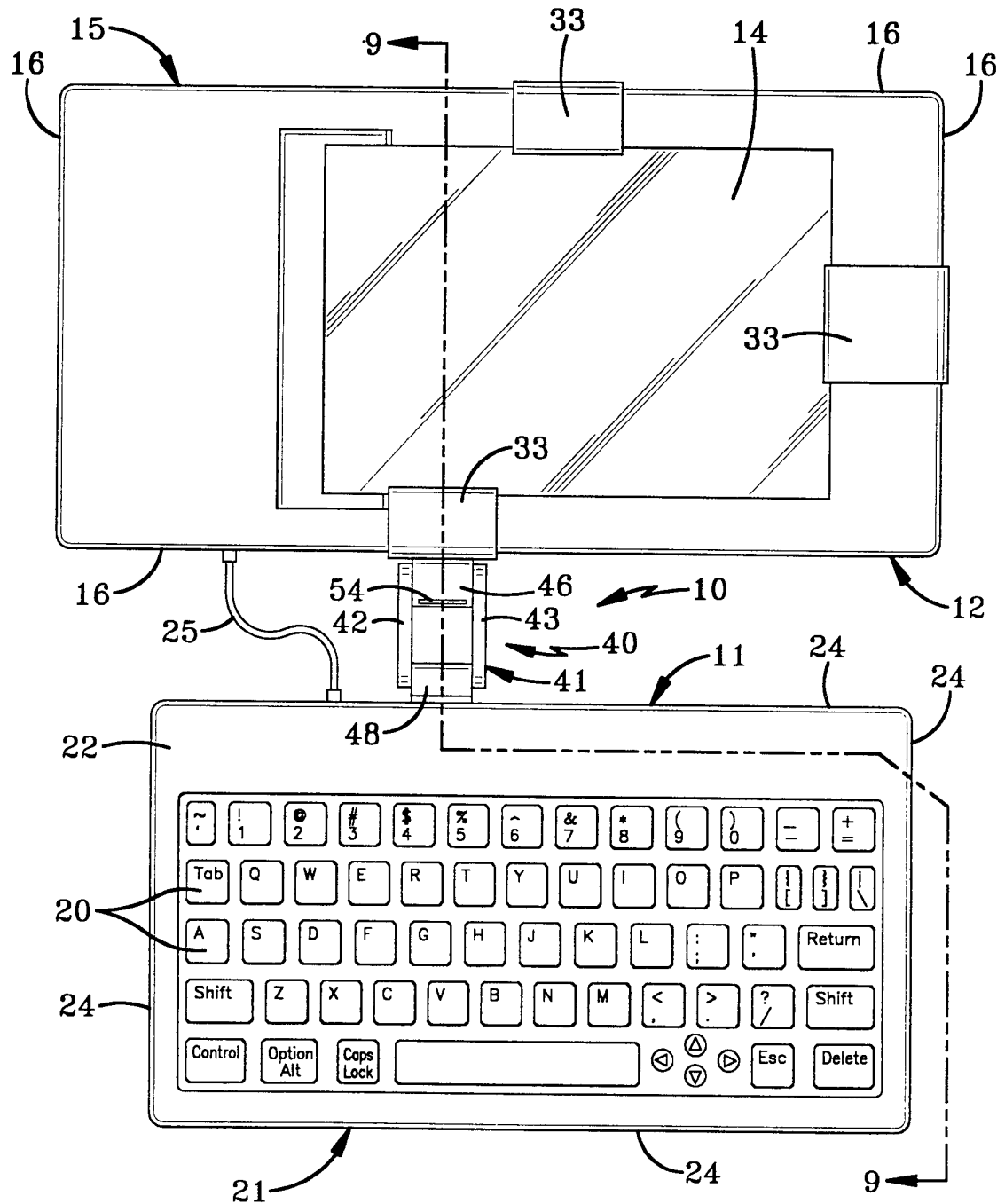

FIG-1

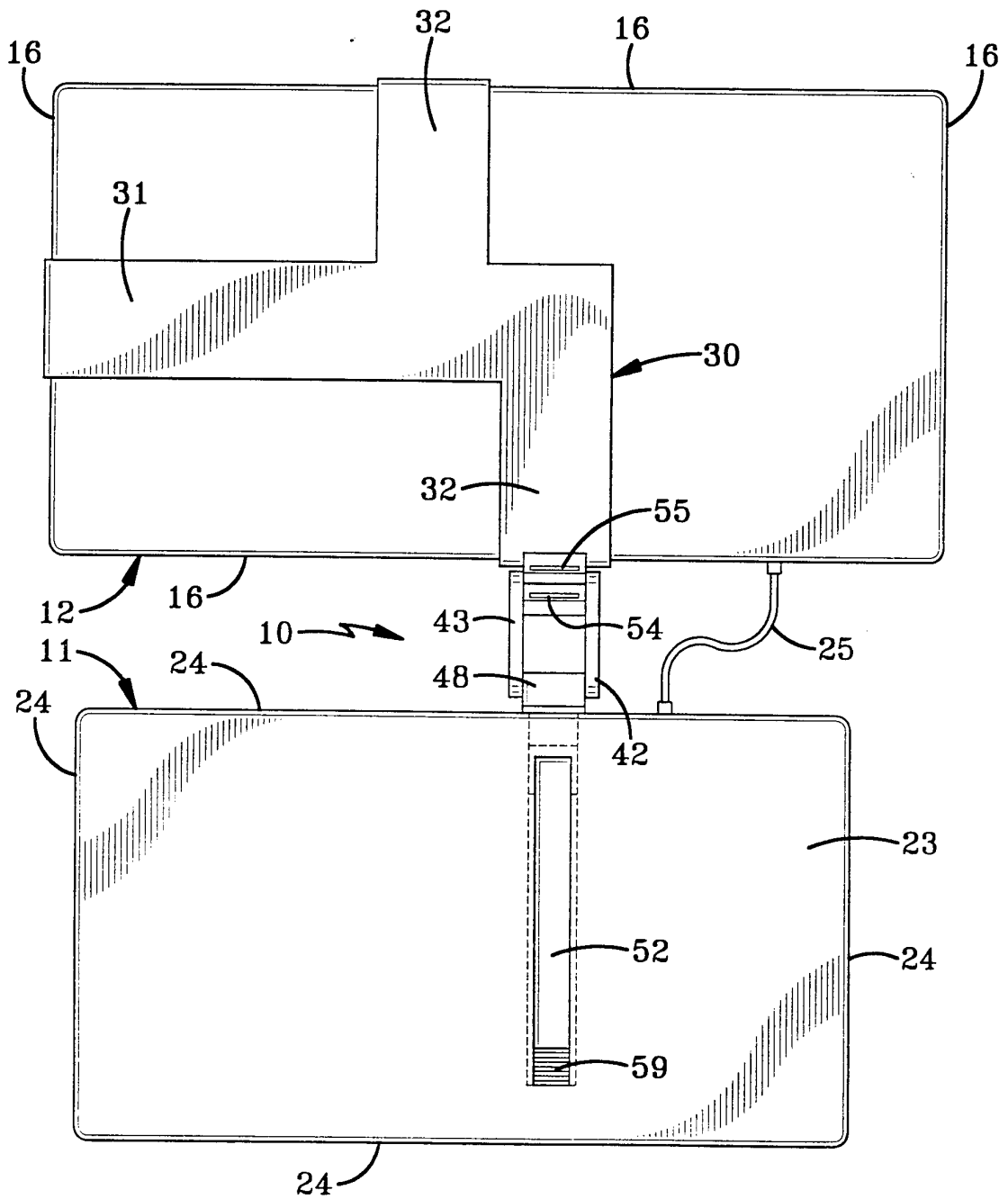

FIG-2

3/8

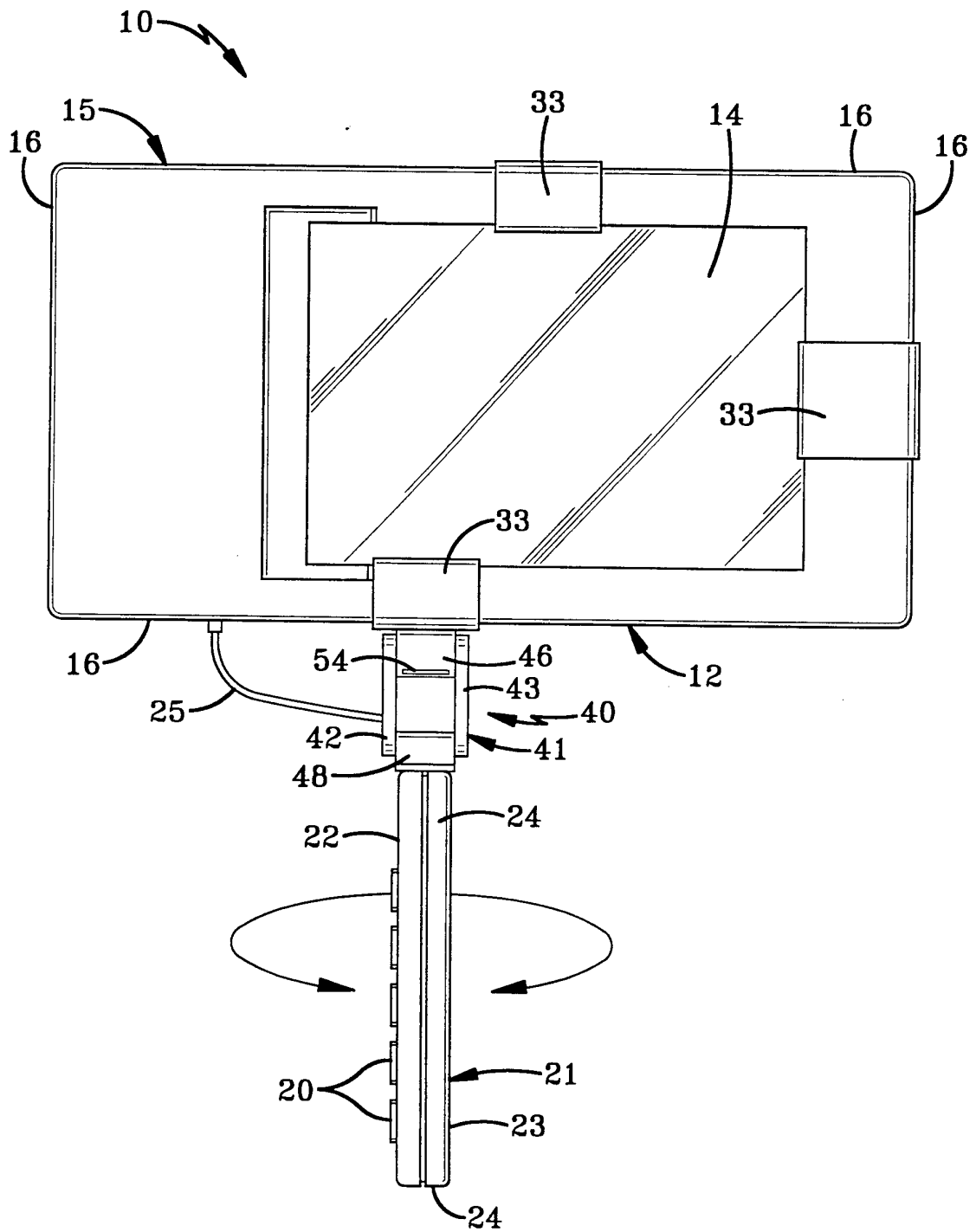

FIG-3

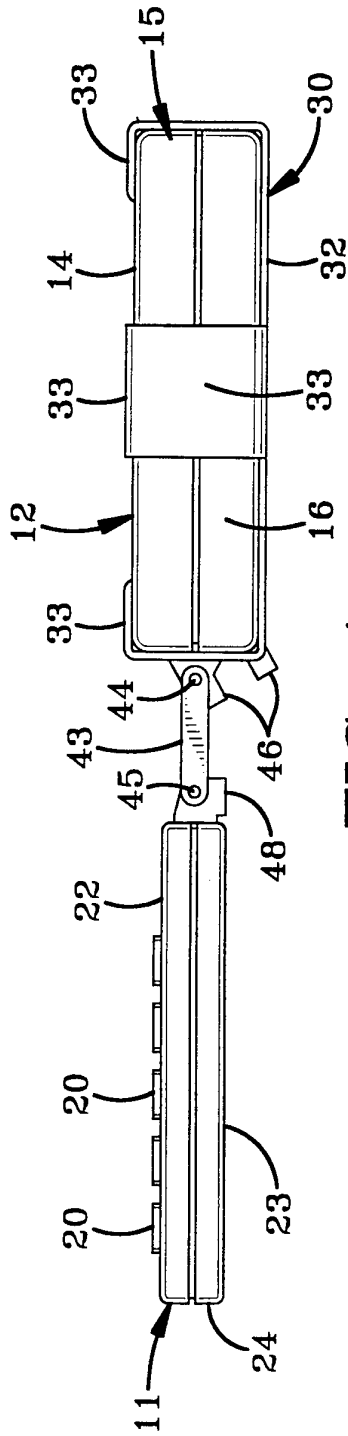

FIG-4

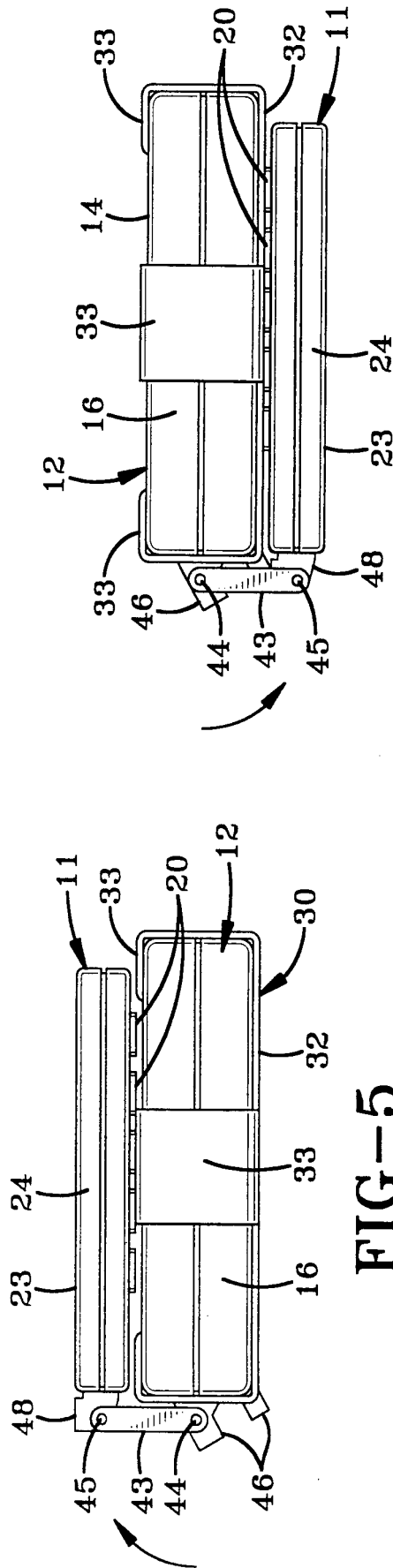

FIG-5

FIG-6

FIG-7

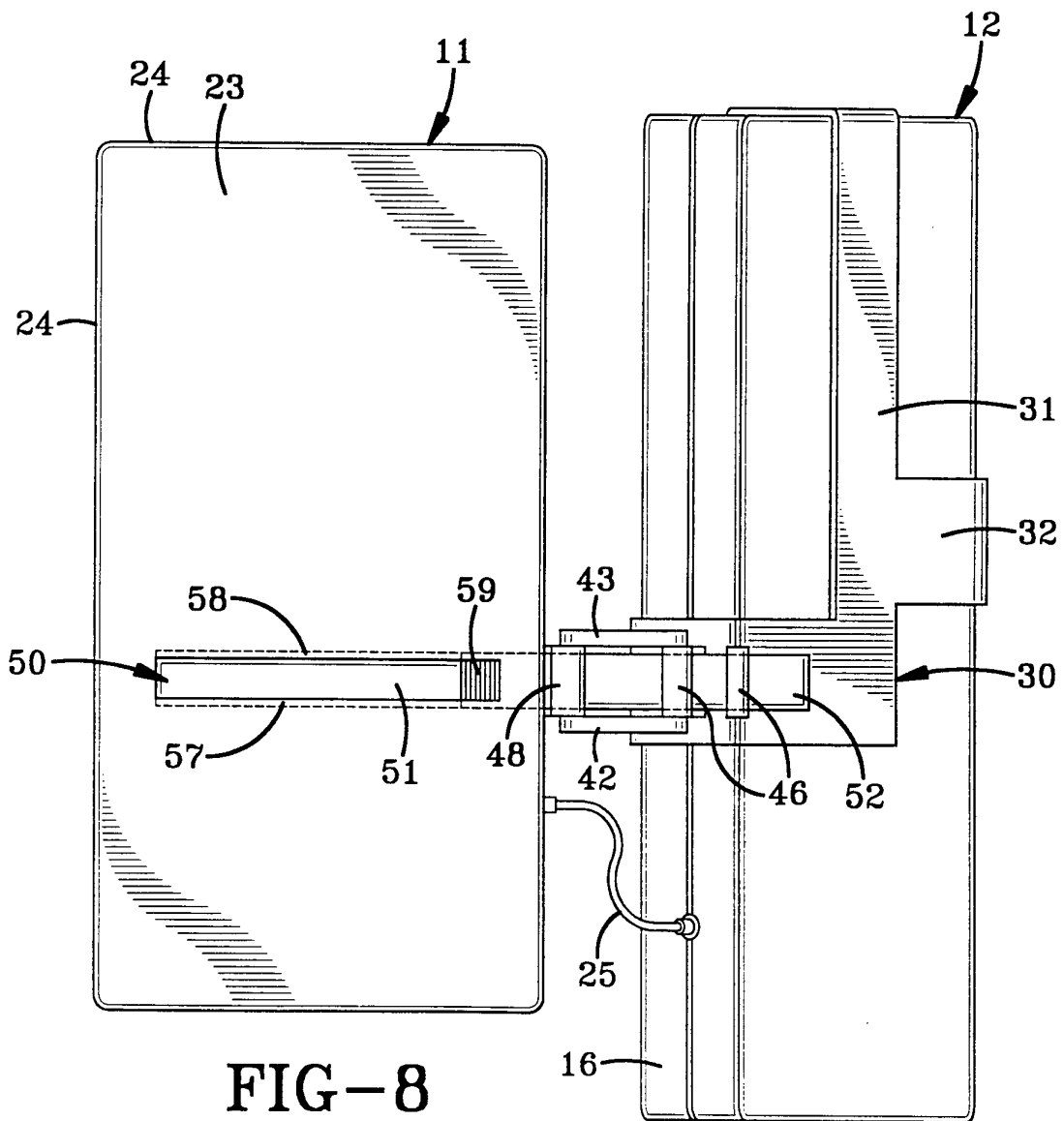
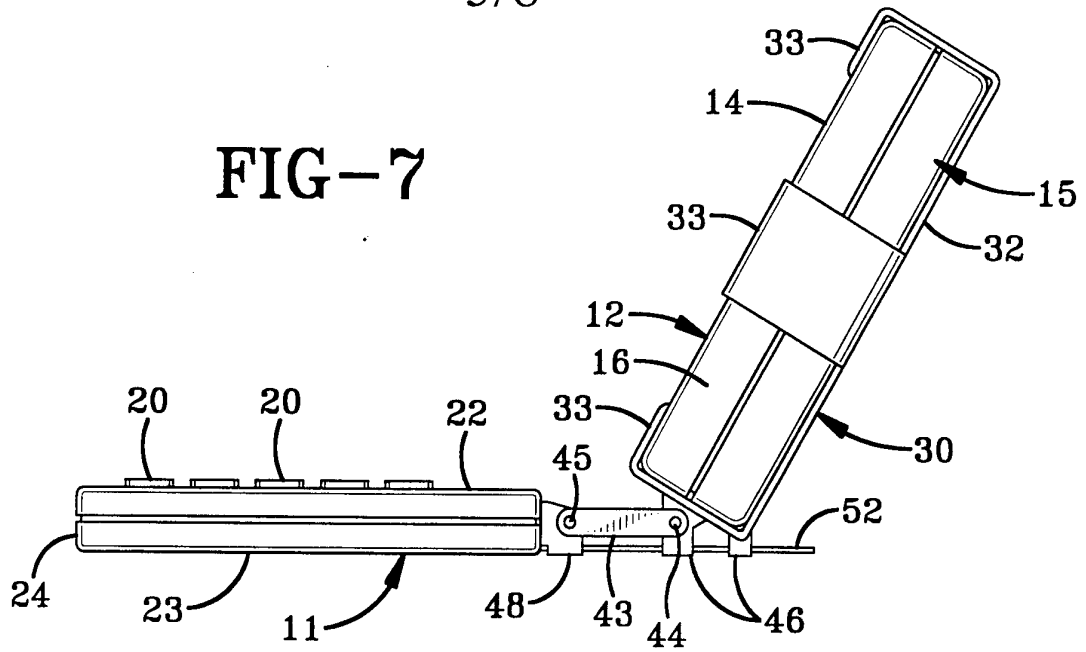

FIG-8

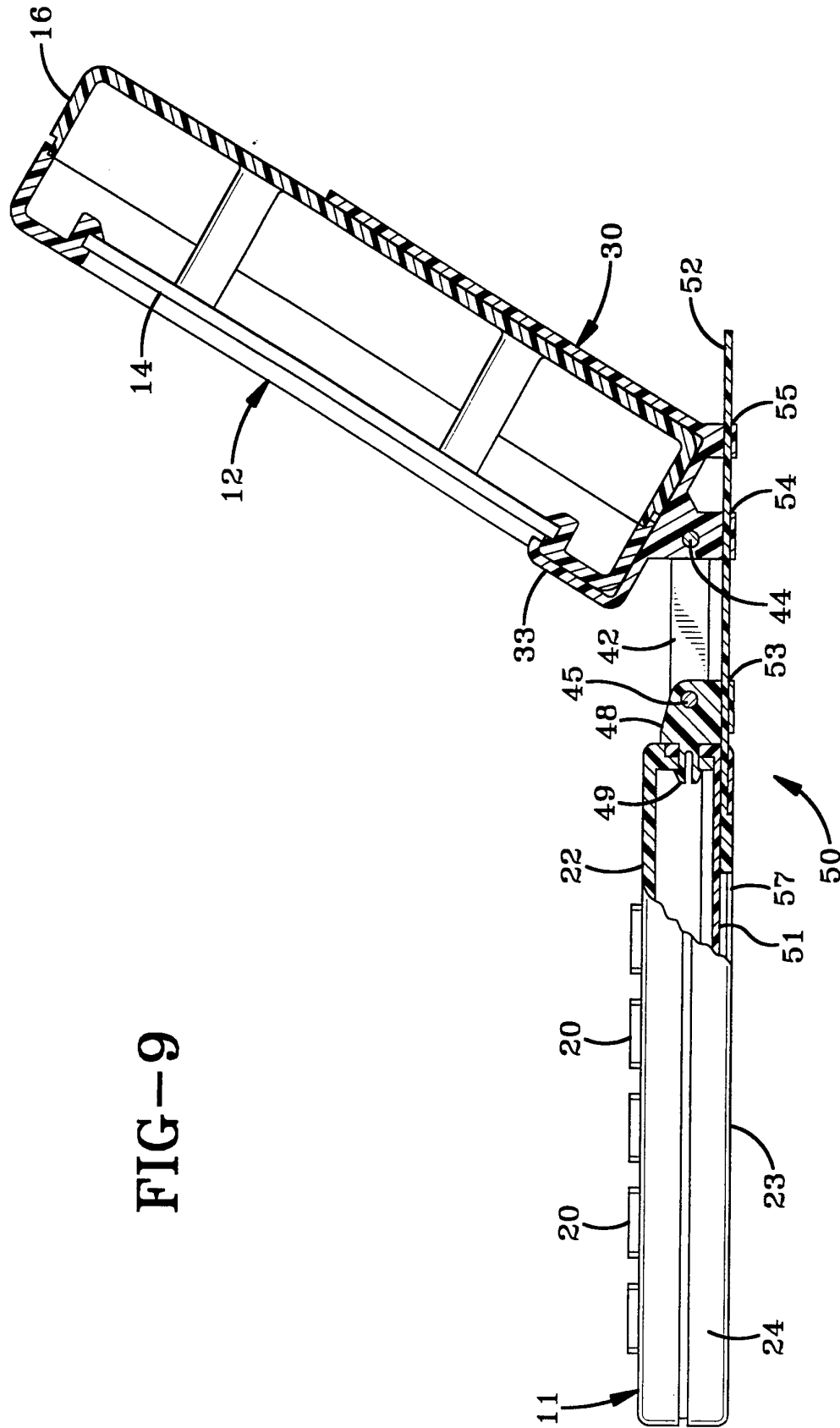
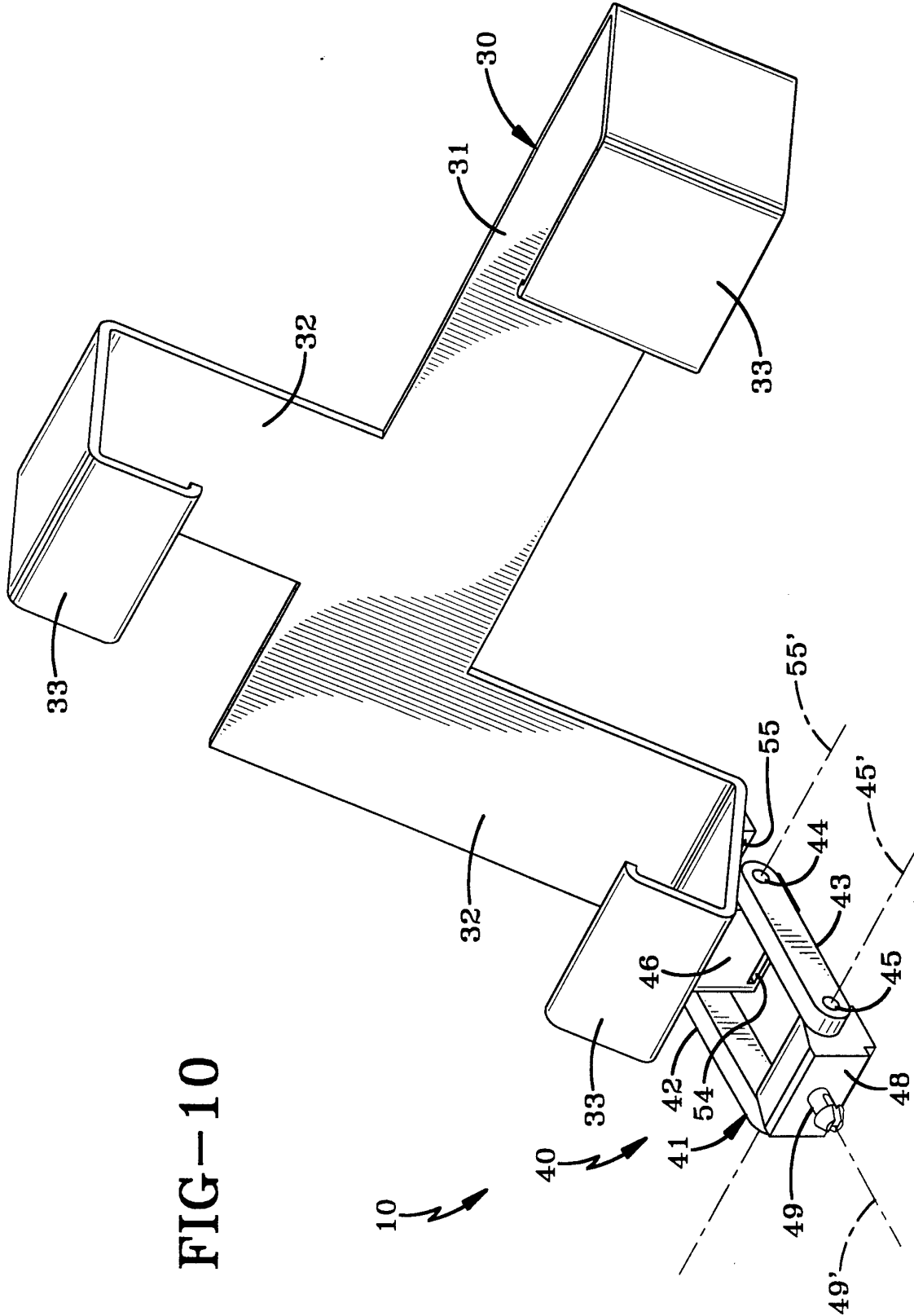

FIG-9



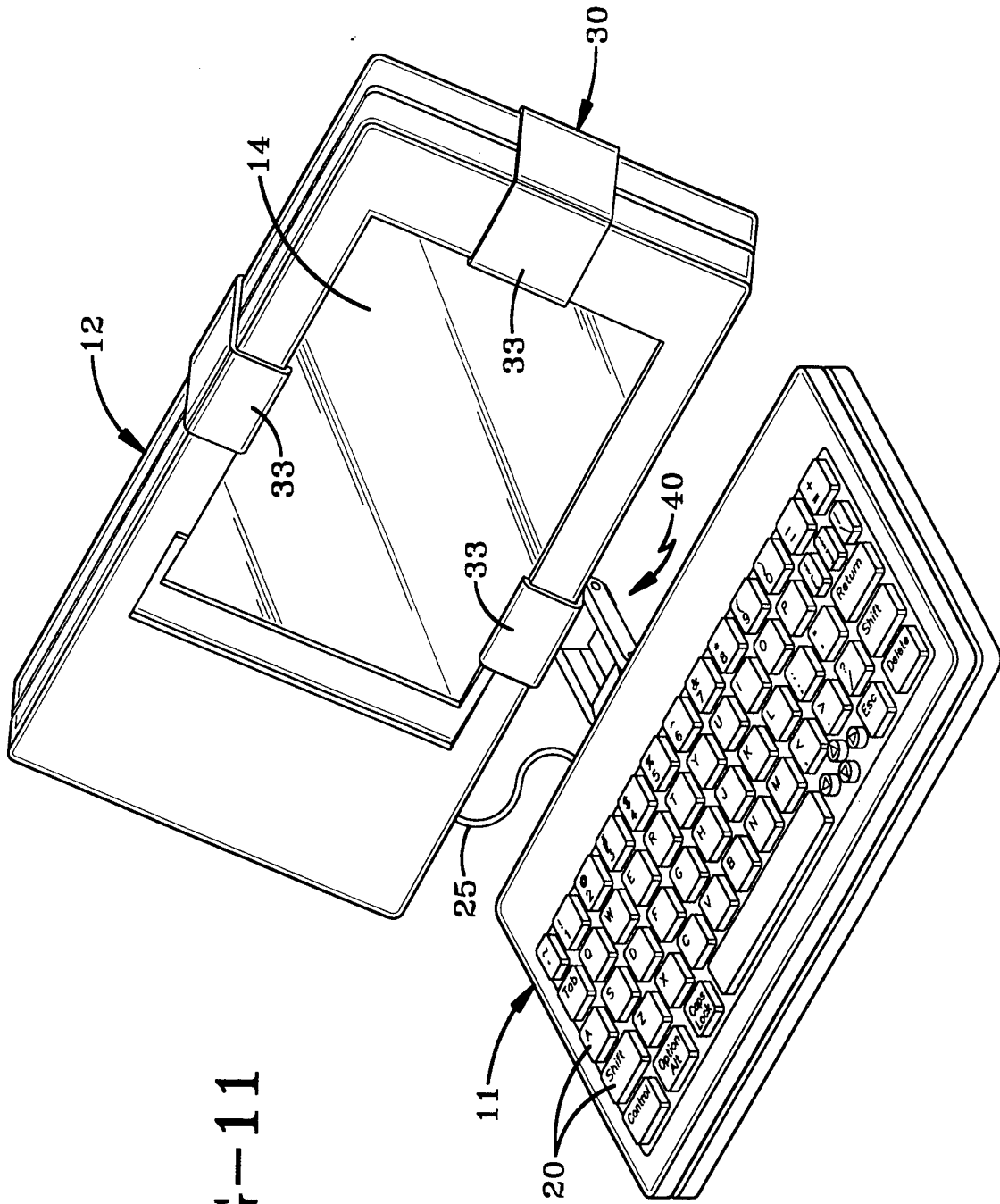

FIG-11

INTERNATIONAL SEARCH REPORT

Intern. application No.
PCT/US96/12352

A. CLASSIFICATION OF SUBJECT MATTER IPC(6) : G06F 1/16 US CL : 361/680, 681; 248/918, 279.1, 442.2; 16/367, 368, 371, 352 According to International Patent Classification (IPC) or to both national classification and IPC		
B. FIELDS SEARCHED Minimum documentation searched (classification system followed by classification symbols) U.S. : Please See Extra Sheet.		
Documentation searched other than minimum documentation to the extent that such documents are included in the fields searched		
Electronic data base consulted during the international search (name of data base and, where practicable, search terms used) APS search terms: 403/clas and ((key board?) or (keyboard?))		
C. DOCUMENTS CONSIDERED TO BE RELEVANT		
Category*	Citation of document, with indication, where appropriate, of the relevant passages	Relevant to claim No.
X	US, A, 5,268,817 (MIYAGAWA ET AL.) 07 DECEMBER 1993, figures 12-16 and 24-30.	1-4,9-14,18
A, P	US, A, 5,494,447 (ZAIDAN) 27 February 1996, figures 9-12.	1-4,9-18
<input type="checkbox"/> Further documents are listed in the continuation of Box C. <input type="checkbox"/> See patent family annex.		
* *A* *E* *L* *O* *P*	Special categories of cited documents: document defining the general state of the art which is not considered to be part of particular relevance earlier document published on or after the international filing date document which may throw doubts on priority claim(s) or which is cited to establish the publication date of another citation or other special reason (as specified) document referring to an oral disclosure, use, exhibition or other means document published prior to the international filing date but later than the priority date claimed	*T* later document published after the international filing date or priority date and not in conflict with the application but cited to understand the principle or theory underlying the invention *X* document of particular relevance; the claimed invention cannot be considered novel or cannot be considered to involve an inventive step when the document is taken alone *Y* document of particular relevance; the claimed invention cannot be considered to involve an inventive step when the document is combined with one or more other such documents, such combination being obvious to a person skilled in the art *&* document member of the same patent family
Date of the actual completion of the international search	Date of mailing of the international search report	
04 SEPTEMBER 1996	15 NOV 1996	
Name and mailing address of the ISA/US Commissioner of Patents and Trademarks Box PCT Washington, D.C. 20231	Authorized officer MICHAEL W. PHILLIPS	
Facsimile No. (703) 305-3230	Telephone No. (703) 308-3191	

INTERNATIONAL SEARCH REPORT

International application No.
PCT/US96/12352

Box I Observations where certain claims were found unsearchable (Continuation of item 1 of first sheet)

This international report has not been established in respect of certain claims under Article 17(2)(a) for the following reasons:

1. Claims Nos.:
because they relate to subject matter not required to be searched by this Authority, namely:

2. Claims Nos.: 5-8
because they relate to parts of the international application that do not comply with the prescribed requirements to such an extent that no meaningful international search can be carried out, specifically:

Please See Extra Sheet.

3. Claims Nos.:
because they are dependent claims and are not drafted in accordance with the second and third sentences of Rule 6.4(a).

Box II Observations where unity of invention is lacking (Continuation of item 2 of first sheet)

This International Searching Authority found multiple inventions in this international application, as follows:

1. As all required additional search fees were timely paid by the applicant, this international search report covers all searchable claims.
2. As all searchable claims could be searched without effort justifying an additional fee, this Authority did not invite payment of any additional fee.
3. As only some of the required additional search fees were timely paid by the applicant, this international search report covers only those claims for which fees were paid, specifically claims Nos.:

4. No required additional search fees were timely paid by the applicant. Consequently, this international search report is restricted to the invention first mentioned in the claims; it is covered by claims Nos.:

Remark on Protest

- The additional search fees were accompanied by the applicant's protest.
 No protest accompanied the payment of additional search fees.

INTERNATIONAL SEARCH REPORT

International application No.
PCT/US96/12352

B. FIELDS SEARCHED

Minimum documentation searched

Classification System: U.S.

361/680-683, 686; 248/917-923, 279.1, 442.2; 16/366, 367, 368, 371, 352; 345/168, 905; 312/223.2; 400/682, 489, 691-693; 364/708.1

BOX I. OBSERVATIONS WHERE CLAIMS WERE FOUND UNSEARCHABLE

2. Where no meaningful search could be carried out, specifically:

No meaningful search could be carried out because the scope of the claims and the corresponding limitations could not be determined. The keyboard and the handheld apparatus are not positively recited as claimed elements. Therefore, without these elements being present the no meaningful search concerning the limitations concerning these elements could be carried out. For example, the first orientation of the keyboard and the display in claim 5 and the grasping of the housing of the handheld apparatus in claim 8.