

*Koehler & Reichardt*  
*Wind Wheel*

*N<sup>o</sup> 36,655.*

*Patented Oct. 14, 1862.*

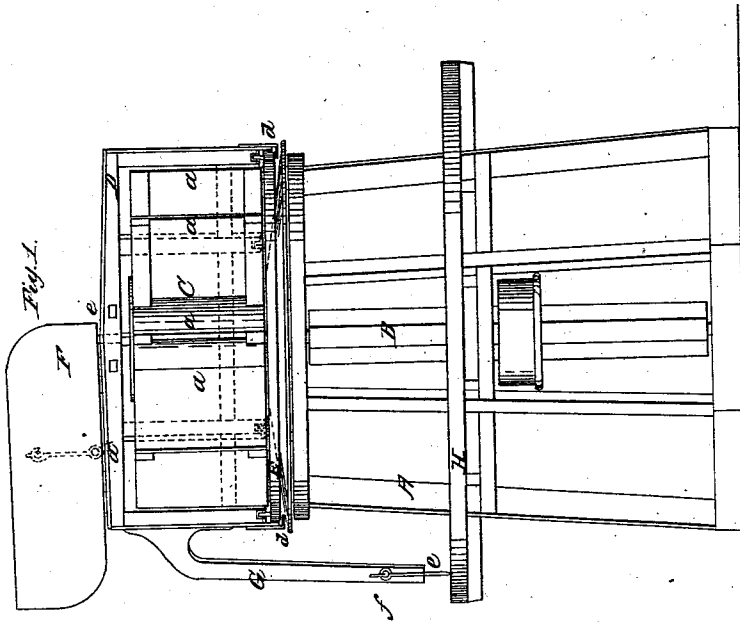
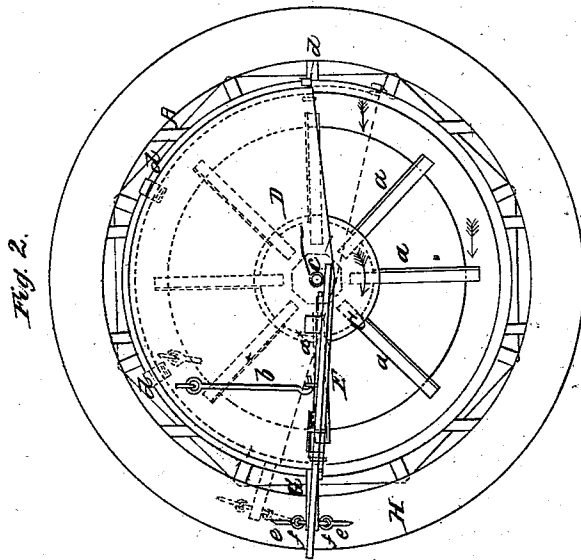

*Witnesses*  
*M. M. Weston*  
*G. W. Reed*

*Inventors*  
*J. H. Koehler*  
*H. Reichardt*  
*per Munn & Co*  
*Attys*

# UNITED STATES PATENT OFFICE.

JOHN W. KOEHLER AND FREDERICK REICHARDS, OF MACON, ILLINOIS.

## IMPROVEMENT IN WIND-WHEELS.

Specification forming part of Letters Patent No. 36,655, dated October 14, 1862.

*To all whom it may concern:*

Be it known that we, JOHN W. KOEHLER and FREDERICK REICHARDS, both of Decatur, in the county of Macon and State of Illinois, have invented a new and Improved Wind-Wheel; and we do hereby declare that the following is a full, clear, and exact description of the same, reference being had to the accompanying drawings, making a part of this specification, in which—

Figure 1 is an elevation of my invention. Fig. 2 is a plan or top view of the same.

Similar letters of reference indicate corresponding parts in the two figures.

This invention consists in the application of a cap or shield to a wind-wheel arranged in such a manner that only a portion of the wheel is exposed to the action of the wind and the latter allowed to act upon or against the former in the most favorable manner for the driving of the machinery, the invention at the same time admitting of the speed of the wheel being regulated as desired, irrespective of the velocity of the wind.

To enable those skilled in the art to fully understand and construct our invention, we will proceed to describe it.

A represents a framing which may be constructed in any suitable manner, to support the wind-wheel and the machinery to be driven by it, and B is a shaft which is placed vertically and centrally in the framing, and has a wind-wheel, C, on its upper end. This wind-wheel is constructed of radial blades or fans *a*, attached to the shaft B at equal and suitable distances apart, as shown clearly in Fig. 2. The wind-wheel C is partially covered by a cap or shield, D, of semi-cylindrical form, and provided, if necessary, with friction wheels or rollers at its lower end, which rest on an annular way, E, on the upper part of the framing A, below the wheel C. This cap or shield D covers about one-half of the wheel, and it is fitted at its upper part on a journal, *c*, in the top of the shaft B, said journal serving as a support for the cap or shield, which is allowed to turn freely on the way E and on the journal *c* as a centre. The cap or shield is provided at its top with a vane, F, which is placed at the edge of the cap or shield and secured to it by a joint or hinge, *a*<sup>x</sup>, as shown

in the drawings, so as to keep the same in such a relative position with the wind as to cause the latter to strike or act against the exposed buckets, as indicated by the arrows in Fig. 2, and thereby rotate the wheel, the cap or shield protecting the buckets from the wind at the opposite side of the shaft B of the wheel. The cap or shield is retained in proper position on the framing A and over the wheel by means of guides or hook-shaped plates *d*, which are attached to the lower part of the cap or shield and project underneath the annular way E, as shown in Fig. 1.

To the cap or shield there is attached a pendent bar, G, which extends downward any suitable or desired distance, and has two rods, *e e*, connected to it at two opposite sides by joints *f*. These rods *e e* are directly over a circular or annular horizontal platform, H, on the framing, and by bracing them on this platform angularly with the bar G the cap or shield D may be retained at any desired point. By this means the speed of the wheel C may be regulated, as desired, for a greater or less number of the buckets of the wheel may be exposed to the wind, as desired. This will be fully explained by referring to Fig. 2, in which an adjustment of the cap or shield to reduce the speed of the wheel is shown in red outline. This holding of the cap or shield, therefore, is an important feature of the invention, for in case the velocity of the wind is such as to cause the wheel to rotate too rapidly when all of its exposed buckets are in a proper position for the wind to act against them, said buckets may be more or less protected from the wind, so as to check the speed of the wheel, as may be required, the vane F in this case being turned down so that the wind cannot act upon it. The vane, when required for use, is held in a vertical position by a rod, *b*<sup>x</sup>.

Having thus described our invention, what we claim as new, and desire to secure by Letters Patent, is—

1. The cap or shield D, when applied to and used in combination with a horizontal wind-wheel, C, substantially as and for the purpose herein set forth.

2. The horizontal circular or annular platform H applied to the framing A, in combi-

nation with the pendent bar G, and rods e e, arranged as shown, for the purpose of adjusting the cap or shield and retaining it relatively with the wind and the exposed buckets of the wheel C, to regulate the speed thereof, as described.

3. The hinged or adjustable vane F, in combination with the rotating and adjustable cap

or shield D and wheel C, as and for the purpose specified.

JOHN W. KOEHLER.  
FREDERICK REICHARDS.

Witnesses:  
JAMES L. PEUKS,  
JOHN ULLRICH.