

Nov. 16, 1937.

A. SHAPIRO

2,099,376

MOTION PICTURE AND SOUND REPRODUCING MACHINE

Filed June 26, 1936

2 Sheets-Sheet 1

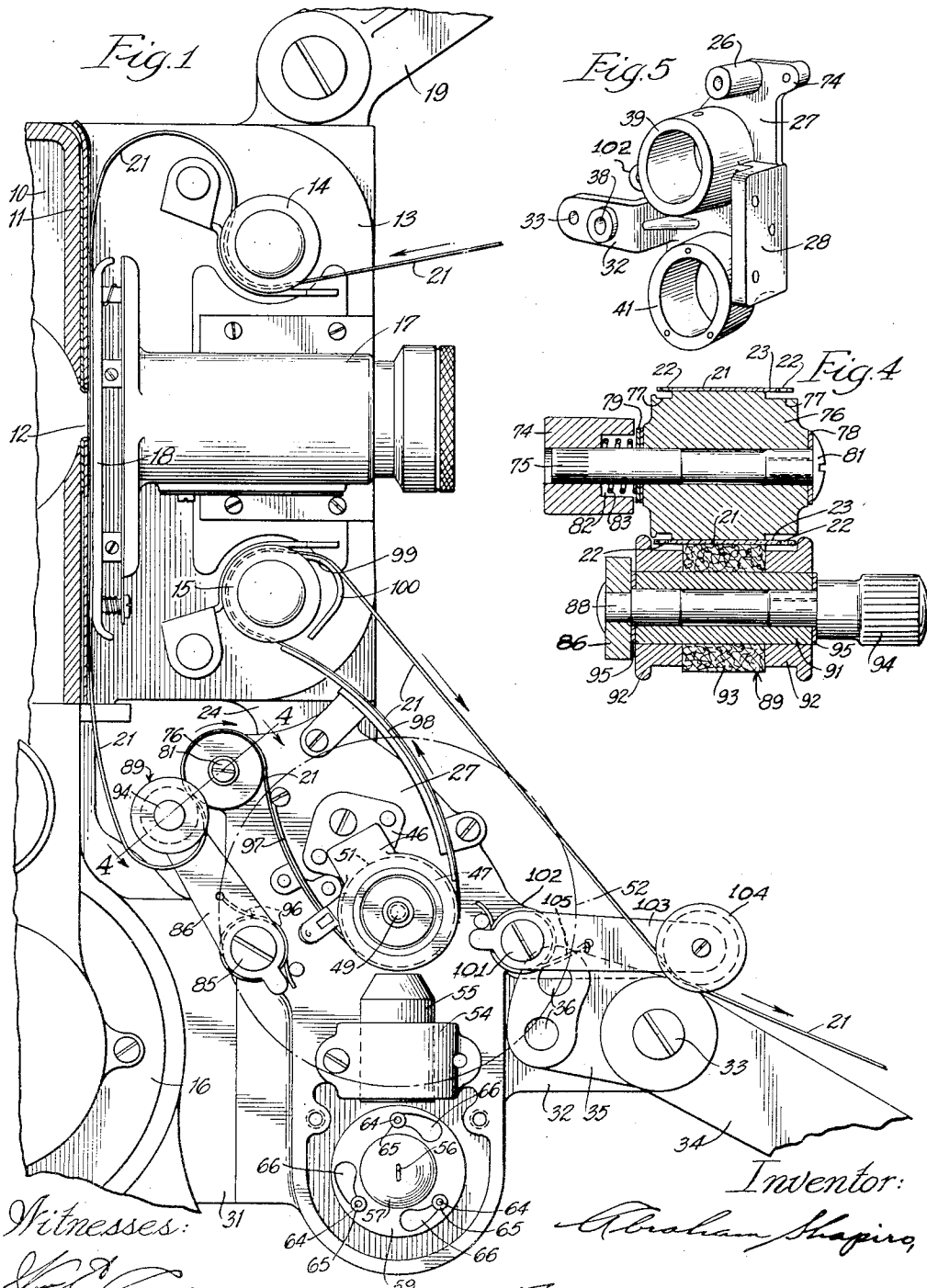

Witnesses:
[Signature]
[Signature]

Inventor:
Abraham Shapiro
 By *Fisher, Clapp, Sears & Pons*
Attys.

Nov. 16, 1937.

A. SHAPIRO

2,099,376

MOTION PICTURE AND SOUND REPRODUCING MACHINE

Filed June 26, 1936

2 Sheets-Sheet 2

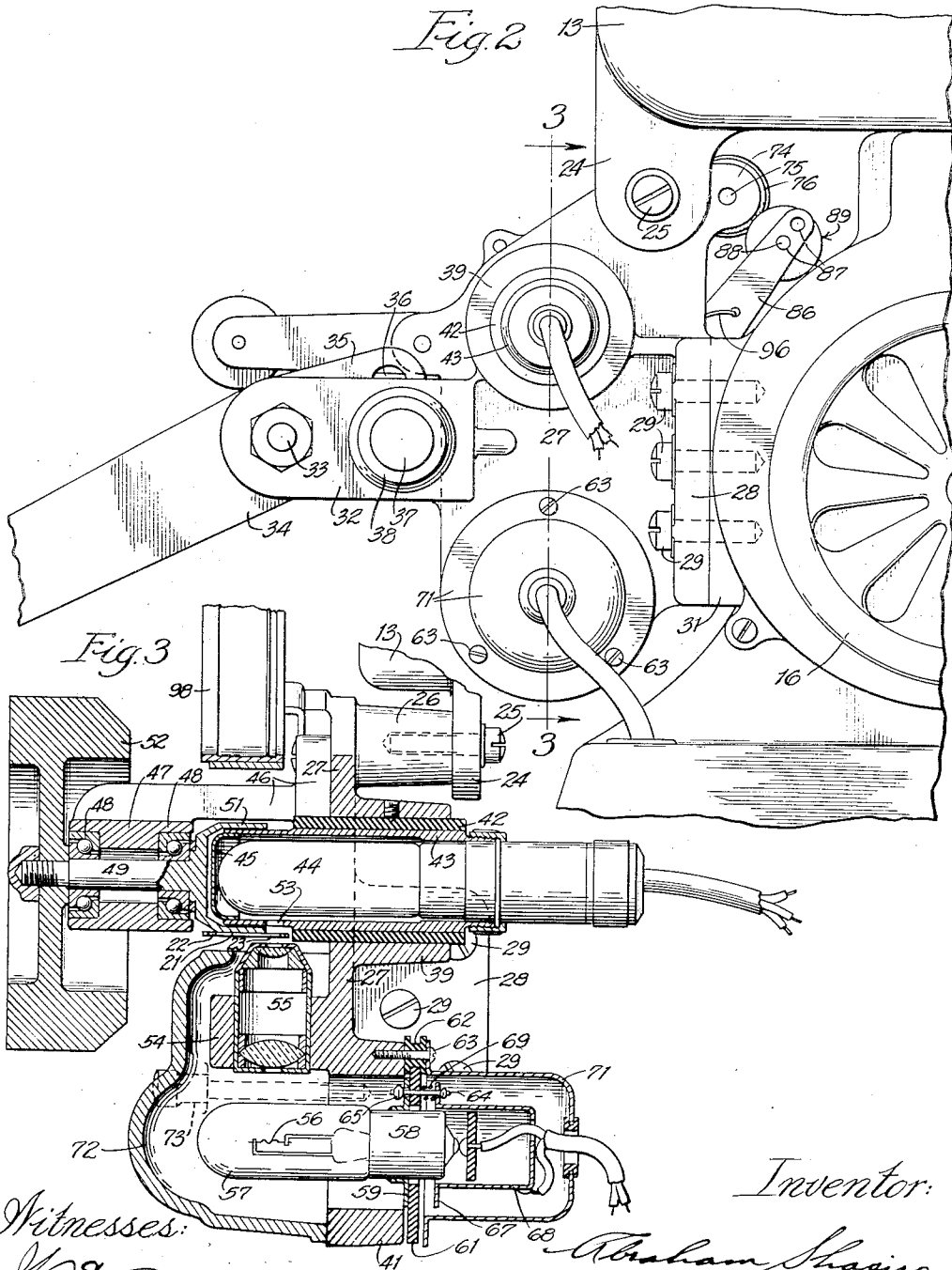

Inventor:

Abraham Shapiro,

By Fisher, Clapp, Soandford, Atty's

Witnesses:

H. E. Anderson
A. J. Debut

UNITED STATES PATENT OFFICE

2,099,376

MOTION PICTURE AND SOUND REPRODUCING MACHINE

Abraham Shapiro, Chicago, Ill., assignor to Universal Stamping & Mfg. Co., Chicago, Ill., a corporation of Illinois

Application June 26, 1936, Serial No. 87,438

6 Claims. (Cl. 179—100.3)

This invention relates to motion picture machines which are equipped with means for producing sound through the well known media of a sound track on the film and an exciter lamp projecting a beam of light through the sound track onto a photo-electric cell, exciting minute currents in the latter which, through a loud speaker, are translated into vocal and instrumental sounds.

One object of the present invention is to provide an improved, compact, and highly efficient sound reproducing mechanism of that type wherein the film having a sound track thereon travels over and rotates a drum, within which drum is a photo-electric cell and a stationary tube encircling the cell and formed with a narrow slot, and an exciter lamp is so mounted as to project a straight light beam across the sound track and through the slot onto the cell.

A quite common fault heretofore existing in the performance of the sound reproducing mechanism of motion picture projectors lies in a more or less tremulous or undulating sound effect that is due to minute vibrations or fluctuations of the film as it passes across the light beam projected through the sound track onto the photo-electric cell. I have found that the sound reproduction may be greatly improved by imposing on the film as it travels through the sound reproducing mechanism a light uniform tension which aids in eliminating such vibrations; and a further feature of the present invention resides in an improved means for thus tensioning the film as it travels across the sound reproducing mechanism.

Still other and more specific objects of the invention will be apparent to persons skilled in the art as the same becomes better understood by reference to the following detailed description, taken in connection with the accompanying drawings in which I have illustrated a preferred embodiment of the improved features of the invention, and wherein:—

Fig. 1 is a fragmentary side elevation, partly in vertical section, of those parts of a motion picture projector to which the present invention relates.

Fig. 2 is an opposite side elevation of the lower portion of Fig. 1.

Fig. 3 is a vertical section through the sound reproducing mechanism, taken on the line 3—3 of Fig. 2.

Fig. 4 is an axial section through the film tensioning mechanism, as seen on line 4—4 of Fig. 1.

Fig. 5 is a perspective detail of the main supporting casting that carries the sound reproducing elements and adjunctive devices, and the arm

of the take-up reel when the machine is used with a sound film.

Since this invention relates particularly to the sound mechanism, the accompanying drawings show only as much of the entire projector as will be of assistance in apprehending the invention.

In the construction illustrated, the casing of the machine, which is only partly shown, includes a lamp compartment 10 having a front wall 11 provided with a central aperture 12 and a forwardly extending gear box 13 in which is mounted a train of gears for driving the film sprockets 14 and 15 from a motor, partially indicated at 16. 17 designates the usual adjustable lens mounting, between the inner end of which and the wall 11 is formed the film guideway 18. A bracket arm 19 mounted on the top of the gear box 13 carries the delivery reel (not shown), and below the aperture 12 is mounted the usual feeding claw (not shown) for effecting the rapid step-by-step movement of the film 21.

The structure above outlined is substantially identical with that disclosed in patents to Sapler No. 1,780,945, November 11, 1930 and No. 1,816,234, July 28, 1931.

Coming now to a description of my present improvement in and relating to the sound mechanism, this mechanism is designed to cooperate with a film such as 21 that is equipped with the usual marginal holes 22 for engagement with the teeth of the sprockets 14 and 15 and, just inside one line of holes, with a sound track photographed thereon at the location indicated by 23 in Figs. 3 and 4. On the under side of the gear box 13 is an integral depending bracket 24 to which is secured by a screw 25 a lateral boss 26 on the upper end of a main mounting plate 27 preferably consisting of a casting having a lateral flange 28 strongly secured by screws 29 to the face of a boss 31 on the frame of the motor 16. On the opposite edge of the plate 27 from the flange 28 is an integral bracket 32 to which is pivoted at 33 an arm 34 that carries the film take-up reel (not shown). As shown in Fig. 1, an inwardly projecting portion 35 of the arm is formed with a pair of holes 36 that cooperate with a spring pressed detent pin 37 mounted in a lateral boss 38 on bracket 32 to support the arm 34 in either of two positions.

On one side of the plate 27 are vertically spaced hollow bosses 39 and 41 (Fig. 3). In boss 39 is mounted an insulating sleeve 42, within which in turn is mounted a brass tube 43 that forms a housing and support for a horizontally disposed photo-electric cell 44. One end of the

housing 43 may be closed by a cap plug 45. Attached to the other side of the supporting plate 27 is a bracket plate 46, on which is an integral hollow boss 47 containing spaced ball bearings 48 for a shaft 49. On the inner end of shaft 49 is a hollow drum 51 that encircles, without contact, the inner end portion of the cell housing 43 and cell 44. Keyed on the opposite end of the shaft 49 is a fly wheel 52. In the cell housing 10 43 is formed the usual narrow slot or slit 53 (Fig. 3) through which the light beam from the exciter lamp is projected onto the photo-electric cell 44.

In a bracket 54 on the opposite side of the plate 15 27 from the bosses 39 and 41 is mounted the usual lens holder and lenses designated as an entirety by 55; and vertically beneath the lower end of the lens holder is the filament 56 of the exciter lamp, the bulb of the latter appearing at 20 57, and the neck 58 of the lamp having soldered thereon a radial flange 59. A fiber washer 61 loosely encircles the neck 58 and is formed with peripheral notches occupied by rubber washers 62 that, in turn, are attached to the outer face 25 of the boss 41 by screws 63. The flange 59 carrying the lamp is removably secured to the washer 61 by three spaced pins 64 formed on one end with knobs 65 that are engaged with bayonet slots 66 (Fig. 1) in the flange 59. The pins 64 30 extend through holes in the washer 61 and also through holes in a flange 67 on the inner end of a lamp socket 68 in rear of and partly surrounding the lamp neck 58, and between the washer 61 and flange 67 are thrust springs 69 encircling 35 the pins 64, and holding the lamp flange 59 securely against the supporting washer 61, and the center terminal of the lamp in contact with one of the wire terminals. Surrounding the socket 68 and secured by the screws 63 is a flanged housing 40 71 through which the leads to the lamp extend.

The lens 55 and lamp 57 are preferably protected by a cover plate 72 that may be attached to the plate 27 as by screws 73.

45 The path of travel of the film below the vertical film guideway and through the sound reproducing mechanism is shown and indicated by arrows in Fig. 1. The drum 51 is driven by the film, and, to insure a continuous and uniform 50 drive it is necessary that the film be under sufficient tension to maintain the rotation of the fly wheel 52, and also to prevent vibration of the film at and adjacent to the point where it crosses the light beam that energizes the photo-electric 55 cell, since any such vibration deleteriously affects the quality of the sound. I have accordingly designed a film tensioning device located in advance of the sound reproducer, and consisting of a pair of friction rolls between which the 60 film passes, at least one of the rolls being associated with means for imposing a light drag on its rotation.

Describing this film tensioning device, the location of which is shown in Figs. 1 and 2 and the 65 structural details of which are shown in Fig. 4, in an ear 74 on the upper end of the mounting plate 27 is secured a stud 75 on which is journaled a brass roll 76. The end portions of this roll are annularly countersunk as shown at 77 70 to avoid contact with the edge portions of the film. On the stud 75 are friction washers 78 and 79 bearing against the ends of the roll 76, and in one end of the stud 75 is a screw 81 the head of which bears on the washer 78 and confines the 75 roller on the stud. In one side of the ear 74

is a recess 82 to house a light thrust spring 83 that creates friction between the washer 78 and the head of the screw 81, thus creating a light drag on the rotary movement of the roll. On one side of the mounting plate 27 is pivoted by 5 a screw 85 the lower end of an arm 86. In the free upper end of arm 86 are a pair of holes 87 (Fig. 2) in either of which is secured a stud 88 on which is journaled a cooperating roll designated as an entirety by 89 in Figs. 1 and 2. The 10 specific structure of roll 89 is shown in Fig. 4, wherein it will be seen that the roll comprises a tubular body 91, ends or heads 92, and an annulus 93 of felt or like soft material between the heads 92. The inner portions of the heads 92 15 are reduced in diameter sufficiently to avoid contact with the edge portions of the film, while the felt sleeve 93 is of sufficient diameter to bear on the front or picture side of the film without marring the latter. In the outer end of stud 88 20 is a knurled thumb screw 94 that confines the roll on its bearing stud between a pair of washers 95. The central portions of both studs are slightly reduced, as shown, to receive oil. A spring 96 urges the arm 86 and its roll 89 toward 25 the cooperating roll 76.

From the friction rolls above described the film travels over a stationary guide shoe 97 mounted on the supporting plate 27, thence around the 30 lower half of the rotary drum 51, thence over a second stationary guide shoe 98 mounted on the plate 27, and thence over the film feed sprocket 15. As the film leaves the sprocket 15 it is lifted to carry the same out of engagement with the sprocket teeth by means of a guide shoe 99 under- 35 lying the film and having a hump 100 extending beyond the path of the sprocket teeth onto which the film rides, thus lifting the film clear of the teeth before the latter withdraw from the holes in the film. 40

The purpose of these shoes 97, 98, and 99 is to prevent vibration of the film as it travels to, through and beyond the sound reproducing mechanism, since, as hereinabove stated, even the slightest vibration of the film as the beam of light 45 travels across the same, impairs the quality of the sound, creating an undulating sound effect. These film guides, however, constitute no part of my present invention, but form the principal subject matter of a copending application of Allen Shoup, 50 Serial No. 87,437, filed June 26, 1936.

Pivoted on a stud 101 mounted in an ear 102 on an edge of the plate 27 is an arm 103, on the free end of which is journaled a pulley 104 which maintains the portion of the film 21 between the 55 feed sprocket 15 and the take-up reel under a light tension, the arm 103 being urged downwardly by a spring 105. The purpose of this pulley is to prevent sudden jerks on the film due to the action of the take-up reel. If a big jerk occurs, as when 60 starting the reel, the spring allows the pulley to rise and thus prevents excessive strain on the film such as might break the latter. This feature, however, is not claimed herein, since it forms in part the subject matter of the copending appli- 65 cation of Allen Shoup, above identified.

The herein described construction of the sound mechanism readily enables the machine to be converted into a "silent" machine—that is, a picture projector using a film having no sound 70 record, by simply withdrawing the screws 25 and 29, and removing the plate 27 and the parts carried thereby, and detaching the take-up reel bracket arm 34 from the bracket 32 and mounting it on the gear box bracket 24. 75

Although but one specific embodiment of this invention has been herein shown and described, it will be understood that specific changes in the structural details and arrangements of the device may be resorted to within the scope of the invention as defined in the following claims.

I claim:

1. In a sound mechanism for use with moving picture films having a sound track, the combination of a mounting plate formed with a transverse opening, an insulating sleeve mounted in said opening, a tube mounted in said sleeve having a portion thereof projecting beyond one end of said sleeve and formed with a narrow slot, a photo-electric cell housed in and supported by said tube, a portion of said cell lying opposite said slot, a hollow rotatable drum formed with an open end encircling with slight clearance only the projecting portion of said tube beyond said slot, said film passing over and driving said drum, and an exciter lamp and lens mounted on said mounting plate laterally opposite said tube in a position to project a straight light beam directly across the sound track on the film through said slot and onto said cell.

2. In a sound mechanism for use with moving picture films having a sound track, the combination of a mounting plate formed with a transverse opening and a hollow integral boss registering with said opening, an insulating sleeve mounted in said boss and extending through said opening, a tube mounted in said sleeve having a portion thereof projecting beyond one end of said sleeve and formed with a narrow slot, a photo-electric cell housed in and supported by said tube, an end portion of said cell lying opposite said slot, a hollow rotatable drum formed with an open end encircling with slight clearance only the projecting portion of said tube beyond said slot, said film passing over and driving said drum with the sound track thereof overhanging said slot, a cap closing the open end of the projecting portion of said tube, and an exciter lamp and lens rigidly mounted on said mounting plate laterally opposite said tube in a position to project a straight light beam directly across the sound track on the film through said slot and onto said cell.

3. In a sound mechanism for use with moving picture films having a sound track, the combination of a mounting plate formed with a transverse opening and a hollow integral boss on one side thereof registering with said opening, an insulating sleeve mounted in said boss and extending through said opening beyond the opposite side of said mounting plate, a tube mounted in said sleeve having a portion thereof projecting beyond

one end of said sleeve and formed with a narrow slot, a photo-electric cell housed in and supported by said tube, an end portion of said cell lying opposite said slot, a hollow drum formed with an open end encircling with slight clearance only the projecting portion of said tube beyond said slot, said film passing over and driving said drum with the sound track thereof overhanging said slot, a cap closing the open end of the projecting portion of said tube, a bracket mounted on the side of said mounting plate opposite said hollow boss, anti-friction bearings mounted in said bracket, a shaft on said hollow drum journaled in said bearings, a fly wheel mounted on a projecting portion of said shaft beyond said bearings, and an exciter lamp and lens rigidly mounted on said mounting plate laterally opposite said tube in a position to project a straight light beam directly across the sound track on the film through said slot and onto said cell.

4. In a machine of the class described, the combination with a film having a sound track thereon, and sound reproducing means through which said film travels, of means for tensioning said film in advance of said sound reproducing means, comprising a pair of rolls between which the film passes, one of said rolls having a soft periphery for contact with the face of the film, means for imposing a drag on the rotation of one of said rolls, and means for lightly compressing said rolls onto the film.

5. In a machine of the class described, the combination with a film having a sound track thereon, and sound reproducing means through which said film travels, of means for tensioning said film in advance of said sound reproducing means, comprising a pair of rolls between which the film passes, one of said rolls having a felt periphery for contact with the face of the film, means for imposing a drag on the rotation of the other roll, and means for lightly compressing said rolls onto the film.

6. In a machine of the class described, the combination with a film having a sound track thereon, and sound reproducing means through which said film travels, of means for tensioning said film in advance of said sound reproducing means, comprising a pair of rolls between which the film passes, the end portions of said rolls being annularly countersunk to avoid contact with the edge portions of the film, means for imparting a drag on the rotation of one of said rolls, and means for lightly compressing said rolls onto the film.

ABRAHAM SHAPIRO. 55