

(19) World Intellectual Property Organization  
International Bureau



(43) International Publication Date  
25 November 2004 (25.11.2004)

PCT

(10) International Publication Number  
WO 2004/101205 A3

(51) International Patent Classification<sup>7</sup>: B23K 20/12,  
31/02, 37/00

East, Salem, UT 84653 (US). PACKER, Scott, M.  
[US/US]; 302 Wood Drive, Alpine, UT 84004 (US).

(21) International Application Number:  
PCT/US2004/013957

(74) Agents: O'BRYANT, David, W. et al.; Morriss O'Bryant  
Compagni, P.C., 136 South Main Street, Suite 700, Salt  
Lake City, UT 84101 (US).

(22) International Filing Date: 5 May 2004 (05.05.2004)

(81) Designated States (unless otherwise indicated, for every  
kind of national protection available): AE, AG, AL, AM,  
AT, AU, AZ, BA, BB, BG, BR, BW, BY, BZ, CA, CH, CN,  
CO, CR, CU, CZ, DE, DK, DM, DZ, EC, EE, EG, ES, FI,  
GB, GD, GE, GH, GM, HR, HU, ID, IL, IN, IS, JP, KE,  
KG, KP, KR, KZ, LC, LK, LR, LS, LT, LU, LV, MA, MD,  
MG, MK, MN, MW, MX, MZ, NA, NI, NO, NZ, OM, PG,  
PH, PL, PT, RO, RU, SC, SD, SE, SG, SK, SL, SY, TJ, TM,  
TN, TR, TT, TZ, UA, UG, US, UZ, VC, VN, YU, ZA, ZM,  
ZW.

(25) Filing Language: English

(26) Publication Language: English

(30) Priority Data:  
60/467,875 5 May 2003 (05.05.2003) US

(71) Applicant (for all designated States except US): SMITH  
INTERNATIONAL, INC. [US/US]; 16740 Hardy Street,  
Houston, TX 77032 (US).

(84) Designated States (unless otherwise indicated, for every  
kind of regional protection available): ARIPO (BW, GH,  
GM, KE, LS, MW, MZ, NA, SD, SL, SZ, TZ, UG, ZM,  
ZW), Eurasian (AM, AZ, BY, KG, KZ, MD, RU, TJ, TM),  
European (AT, BE, BG, CH, CY, CZ, DE, DK, EE, ES, FI,  
FR, GB, GR, HU, IE, IT, LU, MC, NL, PL, PT, RO, SE, SI,

(72) Inventors; and

(75) Inventors/Applicants (for US only): FLAK, Ricky  
[US/US]; 1931 South Washington Avenue, Provo, UT  
84606 (US). STEEL, Russell [US/US]; 667 South 420

[Continued on next page]

(54) Title: APPLICATIONS OF FRICTION STIR WELDING USING A SUPERABRASIVE TOOL

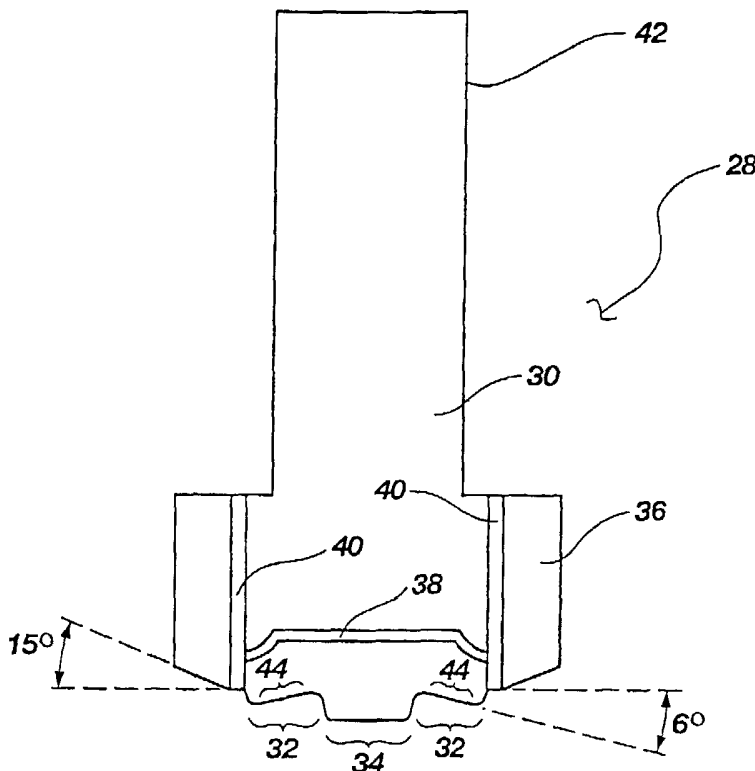

(57) Abstract: The present invention relates to a method of joining segments of high melting temperature materials, that includes frictionally heating a first high melting temperature material and a second high melting temperature material wherein the first high melting temperature material and second high melting temperature material are welded together, without substantially changing the macrostructure and/or the microstructure of the first high melting temperature material and the second high melting temperature material, after application of a frictional force.

WO 2004/101205 A3



SK, TR), OAPI (BF, BJ, CF, CG, CI, CM, GA, GN, GQ, GW, ML, MR, NE, SN, TD, TG).

*For two-letter codes and other abbreviations, refer to the "Guidance Notes on Codes and Abbreviations" appearing at the beginning of each regular issue of the PCT Gazette.*

**Published:**

- *with international search report*
- *before the expiration of the time limit for amending the claims and to be republished in the event of receipt of amendments*

**(88) Date of publication of the international search report:**

4 August 2005

# INTERNATIONAL SEARCH REPORT

International application No.

PCT/US04/13957

**A. CLASSIFICATION OF SUBJECT MATTER**  
 IPC(7) : B23K 20/12,31/02,37/00  
 US CL : 228/112.1,2.1  
 According to International Patent Classification (IPC) or to both national classification and IPC

**B. FIELDS SEARCHED**

Minimum documentation searched (classification system followed by classification symbols)  
 U.S. : 228/112.1,2.1

Documentation searched other than minimum documentation to the extent that such documents are included in the fields searched

Electronic data base consulted during the international search (name of data base and, where practicable, search terms used)

**C. DOCUMENTS CONSIDERED TO BE RELEVANT**

Category *	Citation of document, with indication, where appropriate, of the relevant passages	Relevant to claim No.
X, E	JP 2002-035965 A (AOKI et al.) 5 February 2002, (05.02.2002), abstract.	1-17
A,P	US 6779707 B2 (DRACUP et al.) 24 August 2004 (08.08.2004), entire document	background all
X,P	US 6669075 B2 (COLLIGAN et al.) 13 November 2003, (13.11.2003), col. 1 lines 10-59 and col. 4 lines 35-59.	1-17
X,P	US 6793118 B2 (PALM) 5 February 2004 (05.02.2004), fig. 1, col. 1 lines 5-24 and col 3 line 61 - col 4 line 20.	1-17
X,P	US 6726084 B2 (DUNCAN, JR.) 27 APRIL 2004 (27.04.2004), figs. 3-7 and col. 7 lines 1-49.	1-17
X	US 6227432 B1 (ENOMOTO et al) 8 May 2001 (08.05.2001), figs. 8 and 8A, col. 1 lines 25-50, col. 2 lines 29-45, col 6 lines 51-59 and col 8 lines 3-24.	1-17
X	US 5794835 A (COLLIGAN et al) 18 August 1998 (18.08.1998), fig. 1 and col. 3 line 48 - col 4 line 31)	1-17

Further documents are listed in the continuation of Box C.       See patent family annex.

\* Special categories of cited documents:

"A" document defining the general state of the art which is not considered to be of particular relevance	"T" later document published after the international filing date or priority date and not in conflict with the application but cited to understand the principle or theory underlying the invention
"E" earlier application or patent published on or after the international filing date	"X" document of particular relevance; the claimed invention cannot be considered novel or cannot be considered to involve an inventive step when the document is taken alone
"L" document which may throw doubts on priority claim(s) or which is cited to establish the publication date of another citation or other special reason (as specified)	"Y" document of particular relevance; the claimed invention cannot be considered to involve an inventive step when the document is combined with one or more other such documents, such combination being obvious to a person skilled in the art
"O" document referring to an oral disclosure, use, exhibition or other means	"&" document member of the same patent family
"P" document published prior to the international filing date but later than the priority date claimed	

Date of the actual completion of the international search 12 May 2005 (12.05.2005)	Date of mailing of the international search report <b>20 JUN 2005</b>
Name and mailing address of the ISA/US Mail Stop PCT, Attn: ISA/US Commissioner of Patents P.O. Box 1450 Alexandria, Virginia 22313-1450 Facsimile No. (703) 305-3230	Authorized officer Lynne Edmondson <i>[Signature]</i> Telephone No. (703) 308-0651 <i>[Signature]</i> <b>LYNNE R. EDMONDSON</b> <b>PRIMARY EXAMINER</b> <i>5/12/05</i>