

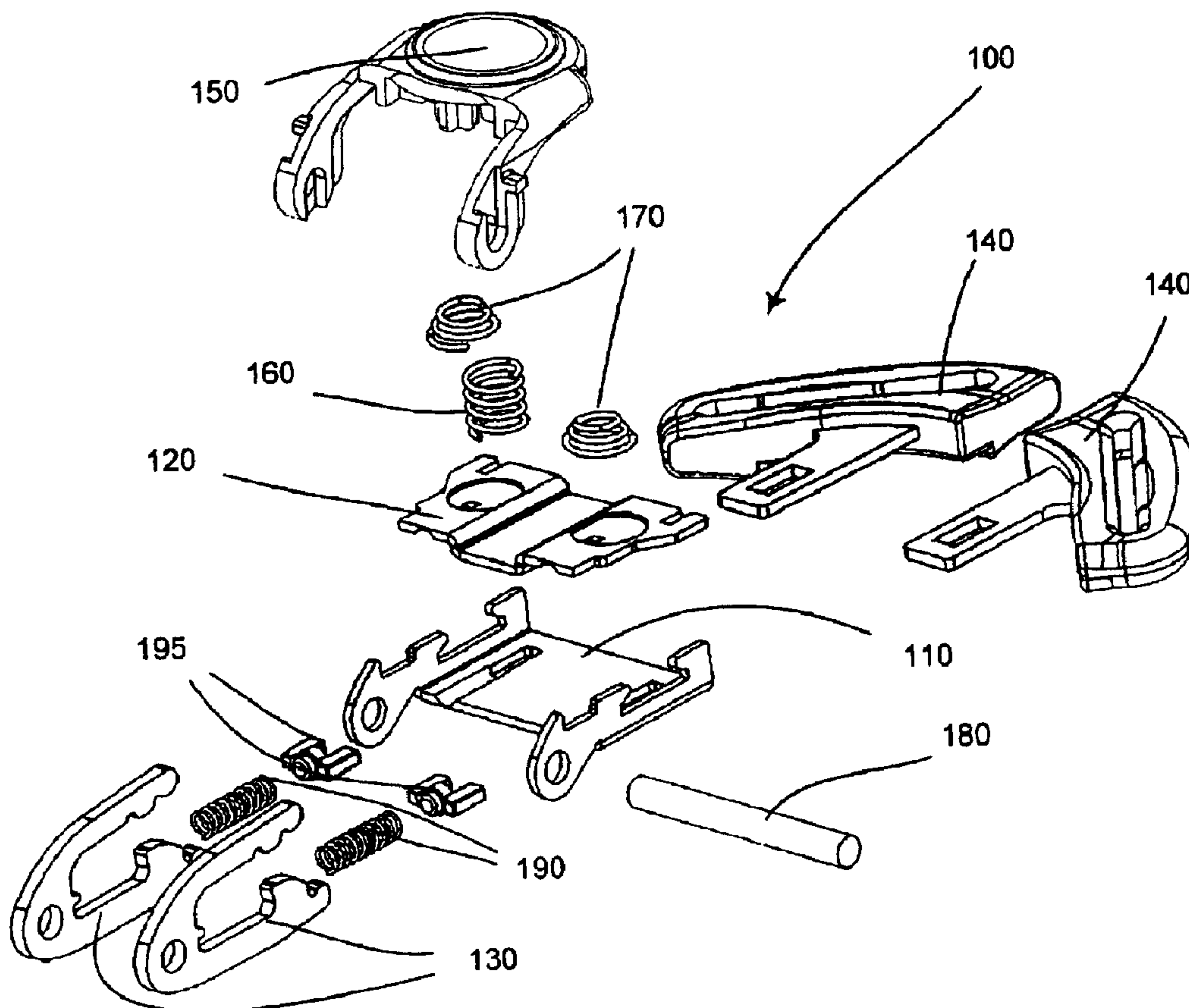

(22) Date de dépôt/Filing Date: 2004/10/22
 (41) Mise à la disp. pub./Open to Public Insp.: 2005/04/24
 (45) Date de délivrance/Issue Date: 2012/03/27
 (30) Priorité/Priority: 2003/10/24 (SE0302823-0)

(51) Cl.Int./Int.Cl. *A44B 11/25* (2006.01),
A44B 11/00 (2006.01), *B60R 22/10* (2006.01)
 (72) Inventeur/Inventor:
 KARLSSON, ROJEL, SE
 (73) Propriétaire/Owner:
 KENDRION HOLMBERGS AB, SE
 (74) Agent: BORDEN LADNER GERVAIS LLP

(54) Titre : DISPOSITIFS DE CEINTURES DE SECURITE POUR SIEGES D'AUTO POUR ENFANTS
 (54) Title: SEAT BELT ARRANGEMENTS FOR CHILD SAFETY SEATS



(57) Abrégé/Abstract:

A buckle mechanism (100) for a seat belt arrangement of a child safety seat comprises a guiding member (230) forming at least one internal cavity (128) for guiding and receiving at least one tongue (141) of a tongue member (140), at least one latch (130) for

(57) **Abrégé(suite)/Abstract(continued):**

engaging with and locking the at least one tongue (141) and disengaging means (150) for disengaging the at least one latch (130) from the at least one tongue (141). The buckle mechanism (100) further has the at least one latch (130) pivotably secured and connected with an anchor pin (180), to which webbing (105) of a seat belt is attached, the other webbing (105) being attached in a way known per se to the at least one tongue member (140). The at least one latch (130) engages with the at least one tongue (141) and the force transmission from the webbings (105) through the mechanism (100) only consists of the at least one tongue (141), the at least one latch (130) and the anchor pin (180).

Summary

A buckle mechanism (100) for a seat belt arrangement of a child safety seat comprises a guiding member (230) forming at least one internal cavity (128) for guiding and receiving at least one tongue (141) of a tongue member (140), at least one latch (130) for engaging with and locking the at least one tongue (141) and disengaging means (150) for disengaging the at least one latch (130) from the at least one tongue (141). The buckle mechanism (100) further has the at least one latch (130) pivotably secured and connected with an anchor pin (180), to which webbing (105) of a seat belt is attached, the other webbing (105) being attached in a way known per se to the at least one tongue member (140). The at least one latch (130) engages with the at least one tongue (141) and the force transmission from the webbings (105) through the mechanism (100) only consists of the at least one tongue (141), the at least one latch (130) and the anchor pin (180).

20

To be published with Fig. 1.

SEAT BELT ARRANGEMENTS FOR CHILD SAFETY SEATS

Technical Field

The present invention relates to seat belt
5 arrangements for automotive applications and, in
particular, to child safety seats, where a buckle mechanism
of the present invention is to be mounted. This buckle
mechanism substantially comprises a guiding member, forming
10 internal cavities for guiding and receiving tongues,
latches for engaging with and locking the tongues and a
button for disengaging the latches from the tongues.

Background of the Invention

Seat belt arrangements for automotive applications
are governed by laws and regulations regarding their design
15 and construction. The seat belt arrangement must be safe to
ensure proper protection of the passenger and the
requirements to achieve this differ from country to
country. Some countries require simultaneous latching of
the tongues in the buckle to avoid that one tongue is
20 improperly latched. In other countries it is required that
the buckle is equipped with ejector means for ejecting the
tongues out of the buckle when the release button is
engaged. This makes it easier to determine if the tongues
are properly latched in the buckle. Buckles in seat belt
25 arrangements for small children (< 9 kg) can be made from
polymeric material whereas buckles for larger children
often comprise metallic load-bearing parts. Various buckles
have been designed, that aim to fulfill the national
requirements, and some of them will be described below.

30 A buckle mechanism of the kind described above is for
example shown in US-A-5,267,377. The buckle mechanism
according to this patent uses a single latch member for
latching of the tongues, where the shoulder seat belts are
attached. The single latch member pivots when only one
35 tongue is inserted into the designated cavity. This means

that when the second tongue is inserted, the first tongue becomes partially unlatched and might remain in a partial-latched position. This means that the tongue appears to be latched but the only force holding the tongue is the
5 friction from being urged against the internal cavity by the latch spring. This can be very dangerous in a potential collision.

Furthermore, the aforementioned governing laws and regulations for buckles include limits for the required
10 opening force of the buckle. There are both upper and lower limits between which exists only a narrow range of acceptable opening force values. Buckles of the constructions shown in US-A-5.267.377, US-A-4.617.705, and US-A-5.813.097 are subject to further restriction of the
15 range of opening forces due to the accumulation of manufacturing tolerances inherent in their making. This can be seen in the fact that the position and orientation of the latch member is controlled by the position of the bent features in the frame member or other supporting members in
20 each of these devices. Each added positioning feature or member makes the exact position and orientation of the latch less precise. This results in greater difficulty during series production in which all buckles must be manufactured to meet the force range limitations with
25 statistical certainty. These buckles are also sensitive to bending of the frame or other supporting members during dynamic loading as occurs during collisions. In these cases, it may be possible for the latch member to rotate to a less than ideal position.

30 Another buckle mechanism of the type described above is disclosed in US-A-5.406.681. This buckle is constructed of polymeric material and used exclusively in seat belt arrangements for small children (< 9 kg). While the construction of this buckle avoids the problems associated
35 with the positioning of the latch member, i.e. accumulated

tolerances and sensitivity to dynamic bending discussed above, its construction mandates that it only be used in applications for small children, due to the fact that the polymeric latch member is secured to the anchor pin which
5 is then secured to the polymeric outer housing. The crash loads must then be transferred through the housing to the webbing, meaning that the magnitude of the loads it can carry is expressly limited through reliance on the polymeric housing to transfer load to the webbing.

10 **The Present Invention**

An extremely short load path may according to the present invention be attained by the features defined in claim 1, whereby the forces from a potential collision are transferred directly from the tongues to an anchor pin on
15 which the latch(es) is secured. The load path is substantially direct and short and this design eliminates the reliance on frame features or other supporting members for the proper positioning of the latch member, resulting in both better management of opening forces and reduced
20 likelihood of sensitivity to dynamic bending effects as well as allowing the frame to be constructed of metal or polymeric material regardless of the size of the child to be restrained.

The buckle mechanism can be arranged with one, two or
25 more latches, which might be independently or simultaneously pivotable about the anchor pin. At least two latches combined with independently pivotable connection to the anchor pin enables independent latching. One embodiment is characterized by having the latches rigidly secured to the
30 anchor pin, thereby forming one integral part. The anchor pin can also be divided before being welded to the latches. In this case, an external or internal pivot is provided to the anchor-pin parts to enable independent rotation of the latch-anchor-pin assembly.

The present invention comprises a guiding member, which can be formed from two separate parts, an upper and a lower plate, or can be made in one part of cast metal or polymeric material. This guiding member provides at least
5 one cavity with guiding sidewalls. If the guiding member is formed with at least one internal sidewall, further cavities are provided. The cavities of the guiding member are provided for receiving and guiding the tongues of the tongue members.

10 The buckle mechanism is further equipped with a button for disengaging the at least one latch from the at least one tongue. This button can be pivotable about the anchor pin. Normally, the button is equipped with an external button return spring but the return spring can
15 also be integrated with the button. If extra opening force is desired, the integrated button return spring can be combined with the external return spring.

When a tongue is entered into a cavity of the guiding member, the latch spring biases the latch to engage with
20 the tongue. This latch spring can be positioned to only act against internal metal parts of the buckle mechanism. This makes it less sensitive to heat, since no polymeric parts are involved. If separate latching is desired, the latches are equipped with separate latch springs. These springs are
25 preferably conical wire springs, which allow long travel with little obstruction.

The above-mentioned design of the buckle mechanism can be self-contained, which means that no housing is necessary for the buckle to remain operable. This is an
30 important feature since the housing easily can be damaged in a potential collision.

The buckle can also optionally be outfitted with ejector springs with or without ejector spring spacers. These members act to eject the tongues out of the guiding
35 member when the button is activated.

The buckle mechanism of the present invention is furthermore designed to be modular, i.e. easily be equipped with alternative features such as ejector springs, ejector spring spacers, button with integrated return spring and/or external return spring, independent or simultaneous latching, one or several tongues, etc.

Brief Description of the Drawings

- Fig. 1 is an exploded view of one embodiment of the buckle mechanism according to the invention.
- 10 Fig. 2 is an exploded view in perspective of a buckle mechanism with its corresponding housing according to the invention.
- Fig. 3 is a perspective view of the lower plate according to the invention.
- 15 Fig. 4 is a perspective view of the upper plate according to the invention.
- Fig. 5 is a perspective view of the latches according to the invention.
- Fig. 6 is a perspective view of the tongue members according to the invention.
- 20 Fig. 7 is a perspective view of one embodiment of the button for opening the buckle.
- Fig. 8 is a perspective view from below of the button as seen in Fig. 7.
- 25 Fig. 9 is a perspective view of an alternative embodiment of the button.
- Fig. 10 is a perspective view of the ejector spring spacers.
- Fig. 11 is an assembly drawing of the button and the lower plate showing how the necks in the button engage the heels of the lower plate.
- 30 Fig. 12 is a perspective view of the guiding member in this case comprising the upper and lower plate.

Fig. 13 is a perspective view of the buckle mechanism with an illustration of how the webbing is attached.

Fig. 14 is a perspective view of the buckle with the housing mounted around the buckle mechanism.

5 Fig. 15 is a perspective view of an alternative embodiment of the guiding member.

Fig. 16 is a perspective view of the guiding member seen in Fig. 15 as seen from another direction.

10 Fig. 17 is a perspective view showing how the latch springs act on the latches.

Description of a Preferred Embodiment

Reference is first made to Fig. 1, showing the different parts of a buckle mechanism 100 according to the present invention in an exploded view. The buckle mechanism
15 100 according to the present invention comprises lower 110 and upper plates 120, two latches 130, two tongue members 140, a button 150, a button return spring 160, two latch springs 170, an anchor pin 180 and optionally two ejector springs 190 and two ejector spring spacers 195. The buckle
20 mechanism 100 is to be placed within a housing 200 consisting of an upper 210 and a lower casing 220, see Figs. 2 and 14.

As is best shown in Fig. 3, the lower plate 110 is formed with a substantially flat central portion 111,
25 having two sidewalls 112 projecting upwards at opposite sides of the flat portion 111. The flat portion 111 is further equipped with two openings 113 for receiving the two latches 130, and with two grooves 114, leading to the openings 113, for receiving the optional ejector springs
30 190 and ejector spring spacers 195, if desired and as explained below. The sidewalls 112 of the lower plate 110 have ears or lugs 115 on the upper edge for receiving and securing the upper plate 120. At their ends to the left in Fig. 3, the sidewalls 112 are further equipped with two

outer anchor-pin holes 116 aligned for receiving the anchor pin 180. A heel 117 is formed to the left on each of the sidewalls 112 for a purpose to be explained.

The upper plate 120, best shown in Fig. 4, is also substantially flat with a recessed central portion forming a channel 121. The channel 121 provides vertical internal guiding walls 122 for guiding the tongues 141 within the cavities 128 formed by the upper 120 and lower plates 110 between the guiding walls 122 and the sidewalls 112, see Fig. 12. The upper plate 120 is further formed with two substantially circular recessions 123 on either side of the channel 121 for receiving the latch springs 170. The upper plate 120 is on the side facing downwards in Fig. 1 formed with grooves 124, analogous to the grooves 114 on the lower plate 110, for receiving the optional ejector springs 190 and ejector spring spacers 195, if desired. Both sides of the upper plate 120 is constructed with lugs 125 for engaging with corresponding ears 115 on the lower plate, resulting in secure attachment of the upper plate 120 on top of the lower plate 110.

Referring to Fig. 5, the latches 130 are U-shaped parts, where a lower shank 131 of each latch 130 is equipped with a shoulder 132 for engaging with corresponding tongues 141 of the tongue members 140 (see Fig. 6). The other shank 133 of each latch 130 is formed with notches 134 for receiving the latch springs 170, as seen in Fig. 17. Each web 135 of the latches 130 is formed with an inner anchor-pin hole 136 for receiving the anchor pin 180. The edge facing forward to the right in Fig. 5, in the valley between the shanks 131, 133, is formed with a neck 137 for receiving the optional ejector springs 190.

Referring to Fig. 6, the tongue members 140 comprise tongues 141 partly embedded in another material, preferably a polymeric material, for embracing webbing 105 of a seat belt, see Fig. 13. The tongues 141 are preferably

manufactured from steel and are generally V-shaped. One shank of each tongue 141 is formed with an aperture 142 for engaging with the latches 130. The other shank of each tongue 141 is formed with an elongated slot 143, for
5 receiving webbing sections 105a and 105b of a seat belt. The shank with the elongated slot 143 is generally covered with the embedding material.

As shown in Fig. 7, the button 150 or the disengaging means for opening the buckle mechanism 100 is formed with a
10 circular (might also be oval, rectangular or any other desired shape) flat portion 151 facing upwards. Legs 152 are integrally formed on opposite sides of the flat portion 151, which legs 152 extend to the side and downward (see also Fig 1). The legs 152 are substantially flat, extending
15 vertically, and are formed with two opposing central anchor-pin holes 153 for receiving the anchor pin 180. The flat portion 151 is on the side facing downwards equipped with generally flat sections 154, best seen in Fig. 8, for engaging the latches 130 during opening of the buckle
20 mechanism 100. The button 150 is on the side facing downwards designed with a button return spring holder 155, shown from below in Fig. 8, for securing the button return spring 160 to the button 150. Moreover, the button 150 is formed with necks 156, which act as stops for the upward
25 rotation of the button 150, when the necks make contact with the heels 117. This is best shown in Fig. 11 at A.

Now referring again to Fig. 1, the button return spring 160 is substantially cylindrical whereas the latch springs 170 are slightly conical, allowing for larger
30 travel of the latches 130 without interference with the latch springs 170.

The anchor pin 180 is cylindrical and is manufactured with substantially the same outside diameter as the inside diameter of the anchor-pin holes 116, 136, 153 in the lower
35 plate 110, the latches 130 and the button 150. The anchor

pin also operates to hold the webbing section 105c of the crotch belt, see Fig. 13.

The optional ejector springs 190 are substantially cylindrical. The ejector springs 190 operate to eject the tongue members 140 from the buckle mechanism 100 after the button 150 has been depressed.

The optional ejector spring spacers 195, see Fig. 10, are formed with a cylindrical portion 196, facing the ejector springs 190, and with two flat end portions 197 for engaging with an end surface of the tongues 141, facing to the left in Fig. 1 and Fig. 6. The ejector spring spacers 195 are preferably manufactured from a polymeric material. The tongues 141 of the tongue members 140 engage the ejector spring spacers 195, which in turn engage the latches 130.

These ejector springs 190 and ejector spring spacers 195 can be excluded since they do not affect the locking function of the buckle mechanism.

The housing 200 comprises an upper 210 and a lower plastic casing 220, as seen in Figs. 2 and 14, which are mounted around the buckle mechanism 100 by screws, rivets, adhesive, ultra-sonic welding, plastic snap-connections or similar.

Alternative embodiments

The above description of a preferred embodiment is not to be considered as limiting. The number of tongues 141, e.g., can vary between one, two or more.

The upper plate 120 can be formed without the channel 121 for use with a single tongue. The tongue will then be wide enough to be guided by the sidewalls 112 and the lower 110 and upper plate 110. The internal guiding walls 122 can alternatively be formed in the lower plate 110 or be inserted and secured as separate parts. The guiding member

can also be manufactured as a single part, see Figs. 15 and 16, through die-casting, extrusion, molding or similar.

The latches 130 can alternatively be rigidly secured to the anchor pin 180. This makes independent latching
5 impossible, unless the anchor pin 180 is divided in two parts, before or after being welded to the latches 130, and the two parts are pivoted around an outer or inner pivot.

The button 150 can alternatively be designed as shown in Fig. 9, where the return spring function of the button
10 return spring 160 is integrally formed in the button 150. The button 150 is in this embodiment formed with springing legs 158 that either rest on the lugs 125 of the upper plate 120 or on the lower casing 220, when assembled. This eliminates the need for a separate button return spring
15 160. The button 150 with the integrated return spring 158 can also be equipped with the separate button return spring 160 for increasing the required opening force. For this reason, the button 150 with the integrated button return spring 158 can also be formed with the button return spring
20 holder 155.

Other types of spring means are also possible, such as blade springs, polymeric springs, fluid springs or similar.

The ejector spring spacers 195 can also be designed
25 for retaining the latches 130 in the open position, after the buckle has been opened. For this purpose a harder material such as die-casting alloys or steel might be suitable.

The preferred material for the load bearing parts is
30 hardened steel but other materials are also possible, such as steel alloys, titanium, die-casting alloys (zinc, aluminum), polymeric materials etc. that do not inherently change the function of the designed part or mechanism. The button 150 and the housing 200 are preferably manufactured

in a polymeric material, but can alternatively be manufactured in steel, die-casting alloys etc.

Assembly

The upper plate 120 is mounted on top of the lower
5 plate 110 and is secured by the lugs 115, 125 of the upper
120 and lower plate 110. This assembly of the lower 110 and
upper plate 120 is called the guiding member 230. The
latches 130 are placed on either side of the channel 121 of
the upper plate 120, aligned with the openings 113 in the
10 lower plate 110 for receiving the shoulders 132 of the
latches 130, and with the shanks of the latches on either
side of the guiding member 230. The optional ejector
springs 190 and ejector spring spacers 195 or only the
optional ejector springs 190 are inserted between the upper
15 120 and lower plate 110 and are kept in place by the
latches 130. The button return spring 160 is placed on top
of the upper plate 120 and the latch springs 170 are placed
in their corresponding recessions 123. The latches 130 are
placed in position for engaging with the latch springs 170.
20 The button 150 is placed on top of the latches 130 and the
button return spring 160, above the upper plate 120. The
anchor-pin holes 116, 136, 153 of the button 150, the lower
plate 110 and the latches 130 are aligned for receiving the
anchor pin 180. The anchor pin 180 is inserted and is
25 locked in place by some locking means, e g the housing 200,
a locking ring (not shown), or by riveting. Finally, the
buckle mechanism 100 is placed in the lower casing 210 and
the upper casing 220 is placed on top of the mechanism 100.
The two casings are joined by some fastening means.

30 The preferred embodiment is modular and is built for
receiving optional features such as ejector springs 190,
ejector spring spacers 195 and an additional button return
spring (integrated 158 and external 160), but their

inclusion is up to the individual customer, or regulatory requirements.

Operation

The buckle mechanism 100 is now ready for receiving
5 the tongues 141 of the tongue members 140. The tongues 141
are inserted in the cavities 128 provided between the upper
120 and lower plate 110 and between the guiding walls 122
and the sidewalls 112. The tongues 141 engage the shoulders
132 on the latches 130 and force them to rotate about 5-
10 10°. The tongues 141 can then be depressed further and at
the end of the depression the shoulders 132 on the latches
130 engage with the apertures 142 in the tongues 141, as
the latch springs 170 push the shoulders 132 of the latches
130 back to their locking position.

15 The latches 130 can rotate independently and the
tongues 141 can thus be entered independently. This is in
the art referred to as independent latching.

The tongues 141 might engage the optional ejector
springs 190 or the optional ejector springs 190 and ejector
20 spring spacers 195. The ejector springs 190 function to
automatically eject the tongues 141 when the latches 130
are removed from the apertures 142 in the tongues 141 by
depressing the button 150.

Depressing the button 150 opens the buckle mechanism
25 100 by forcing the latches 130, via the flat sections 154,
to rotate and eventually disengage from the tongues 141.

CLAIMS:

1. A buckle mechanism for a seat belt arrangement of a child safety seat comprising:
a guiding member forming at least one internal cavity for guiding and receiving at least one tongue respectively associated with at least one tongue member;
at least one latch for engaging with and locking the at least one tongue and disengaging means for disengaging the at least one latch from the at least one tongue, wherein:
the at least one latch is pivotable and connected with an anchor pin to which a section of seat belt webbing is attached, another webbing section being attached to each of the at least one tongue members, and the at least one latch engages with the at least one tongue, the force transmission from the webbing sections through the mechanism only consisting of the at least one tongue, the at least one latch and the anchor pin.
2. A buckle mechanism according to claim 1, wherein the at least one latch is pivotally connected with the anchor pin.
3. A buckle mechanism according to claim 1, wherein the buckle mechanism has at least two latches.
4. A buckle mechanism according to claim 3, wherein the at least two latches are independently pivotable about the anchor pin.
5. A buckle mechanism according to claim 3, wherein the at least two latches are rigidly secured to the anchor pin.
6. A buckle mechanism according to claim 3, wherein the anchor pin is divided into at least two parts, where each anchor-pin part is rigidly secured to each of the at least two latches, and the thus formed at least two parts are pivotable about an outer or inner pivot.

7. A buckle mechanism according to claim 1, wherein the guiding member comprises a lower and an upper plate.
8. A buckle mechanism according to claim 7, wherein the guiding member has first sidewalls for providing, together with the lower and upper plate, the at least one internal cavity for guiding the at least one tongue of the at least one tongue member.
9. A buckle mechanism according to claim 8, wherein the guiding member has internal guiding second sidewalls, for providing together with the first sidewalls at least two said internal cavities for guiding at least two tongues of the at least one tongue member.
10. A buckle mechanism according to claim 1, wherein the guiding member is constructed in one piece from die-cast metal or polymeric material.
11. A buckle mechanism according to claim 10, wherein the guiding member has internal guiding sidewalls for providing at least two internal cavities for guiding at least two tongues of the at least one tongue member.
12. A buckle mechanism according to claim 1, wherein the disengaging means comprises a button for disengaging the at least one latch from the at least one tongue.
13. A buckle mechanism according to claim 12, wherein the button is pivotally connected with the anchor pin.
14. A buckle mechanism according to claim 12, wherein the button is equipped with an external return spring.
15. A buckle mechanism according to claim 14, wherein the button has both an integrated return spring and the external button return spring.

16. A buckle mechanism according to claim 12, wherein the button has an integrated return spring.

17. A buckle mechanism according to claim 16, wherein the integrated return spring of the button is formed by at least one springing leg which abuts the guiding member or on a housing for containing the buckle mechanism.

18. A buckle mechanism according to claim 1, wherein the buckle mechanism has at least one latch spring means for biasing the at least one latch to a locking position when the at least one tongue is pushed into its locked position.

19. A buckle mechanism according to claim 18, wherein the buckle mechanism has at least two latches and the at least one said spring means independently biases each of the at least two latches to the locking position when the at least one tongue is pushed into its locked position.

20. A buckle mechanism according to claim 18, wherein the buckle mechanism has the latch spring means acting only on internal metal parts of the buckle mechanism.

21. A buckle mechanism according to claim 18, wherein the latch spring means are wire springs.

22. A buckle mechanism according to claim 21, wherein the latch spring means are conical wire springs.

23. A buckle mechanism according to claim 1, wherein the buckle mechanism has latch spring means for biasing the at least one latch to a locking position when the at least one tongue is pushed into its locked position and the buckle mechanism is self-contained with only the anchor pin, the at least one latch, the latch spring means, the guiding member and the disengaging means.

24. A buckle mechanism according to claim 1, further comprising ejector springs for biasing the at least one tongue out of the at least one internal cavity when the at least one latch is disengaged from the at least one tongue.

25. A buckle mechanism according to claim 24, further comprising at least one ejector spring spacer, being interposed between the at least one ejector spring and the at least one tongue during locking operation.

26. A buckle mechanism according to claim 25, wherein the at least one ejector spring spacer is guided by grooves in the guiding member.

27. A buckle comprising a buckle mechanism according to any one of claims 1-26 and a housing comprising an upper and a lower casing, wherein said housing contains said buckle mechanism.

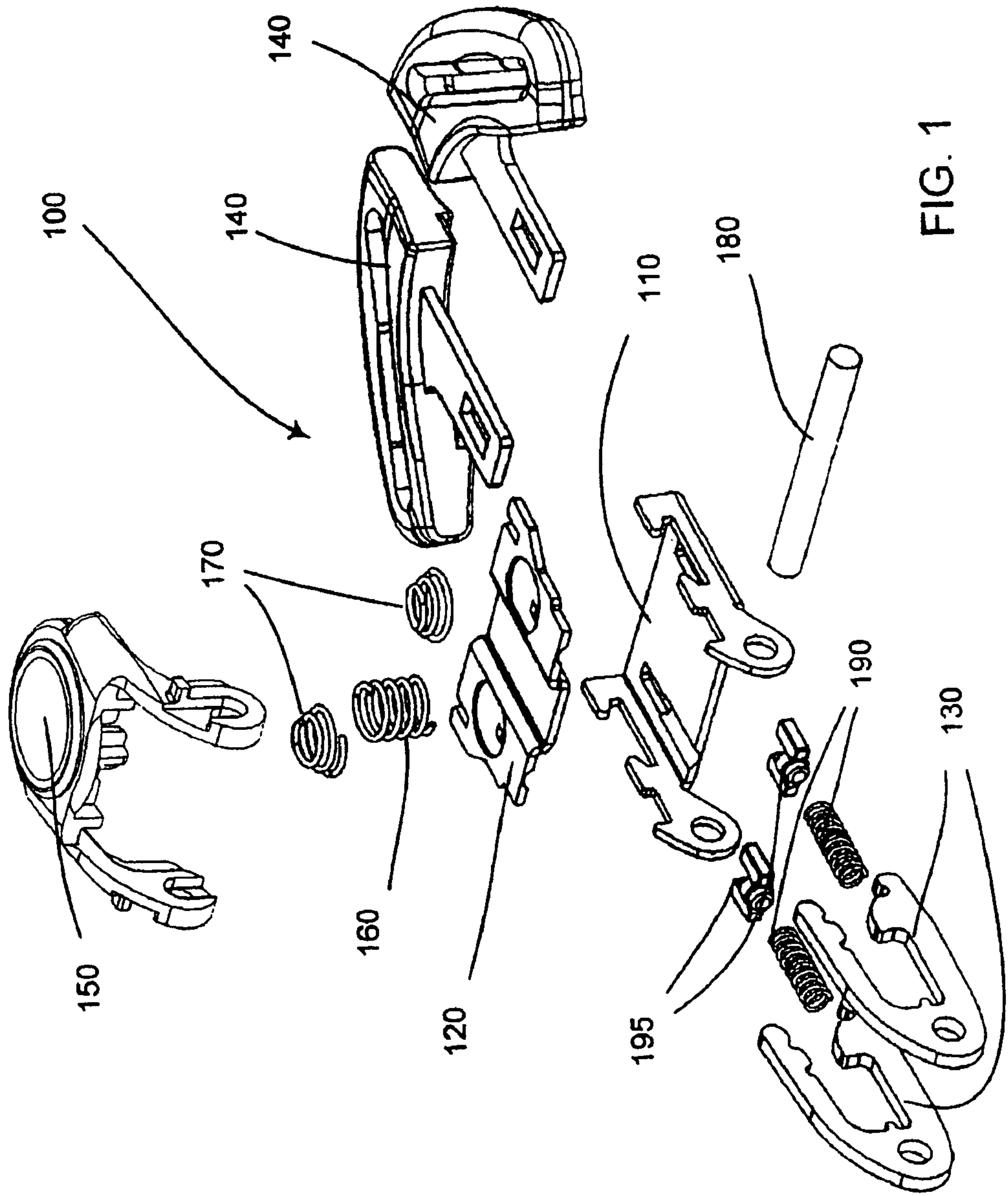

FIG. 1

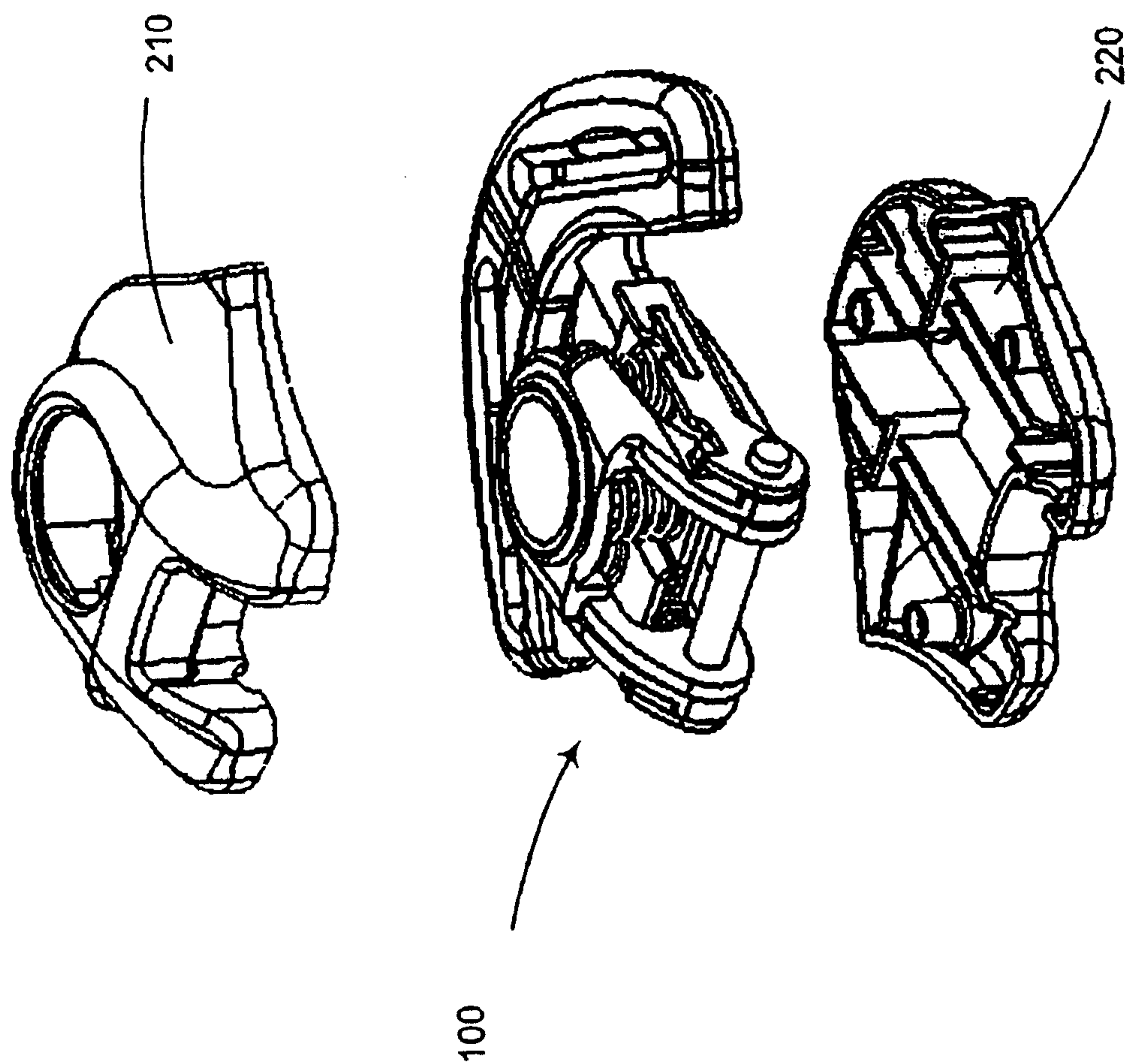

FIG. 2

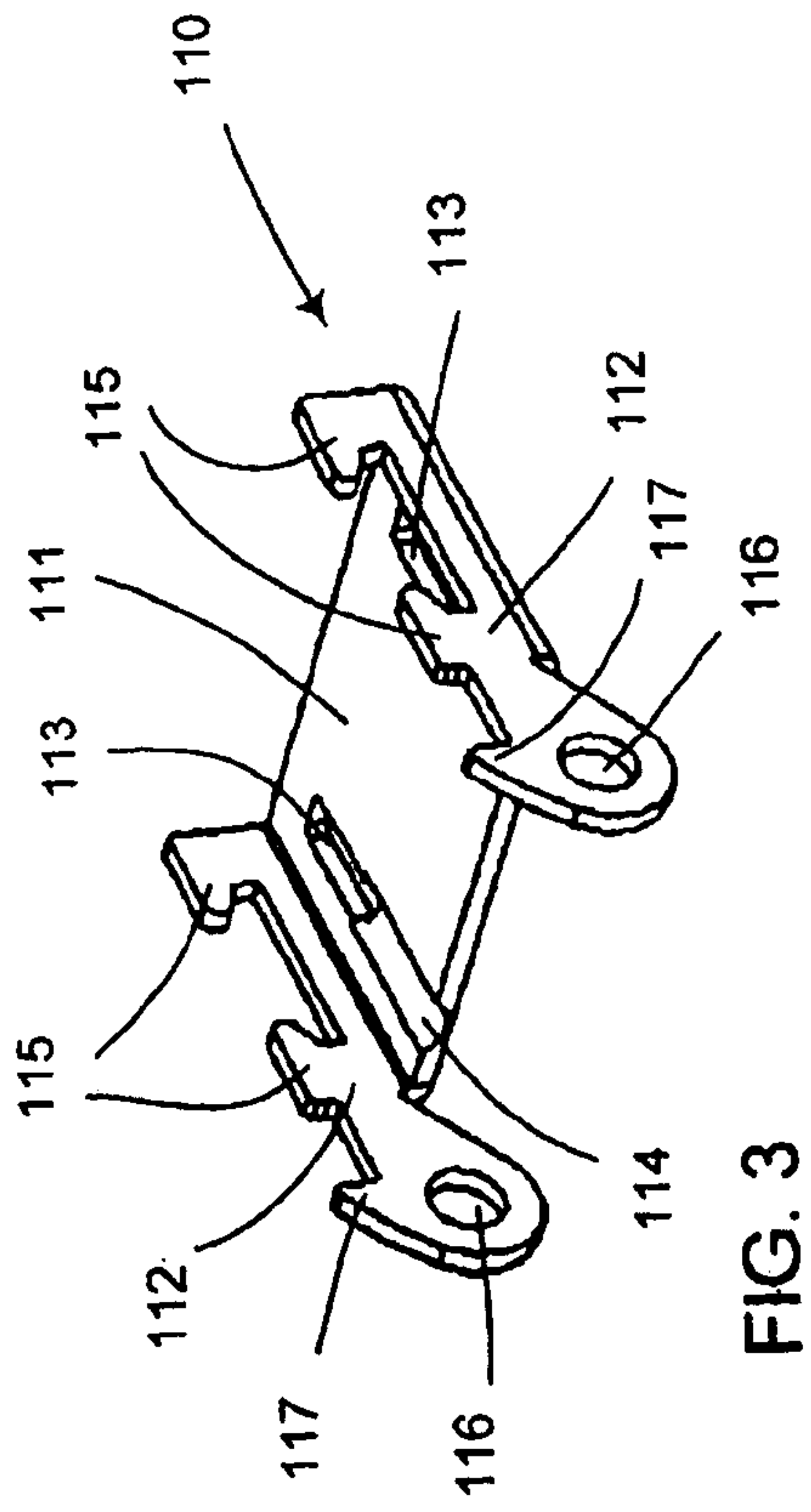

FIG. 3

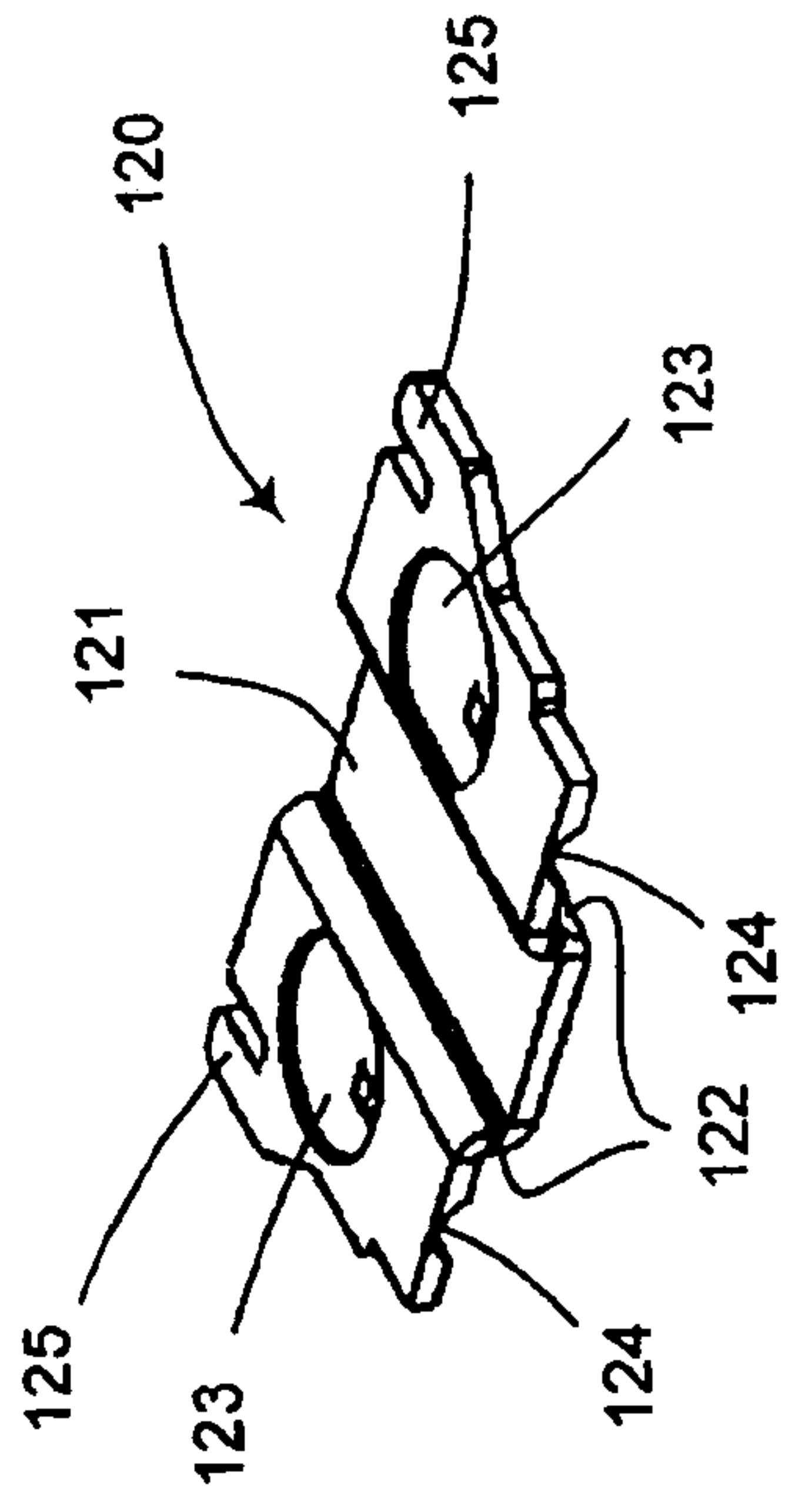

FIG. 4

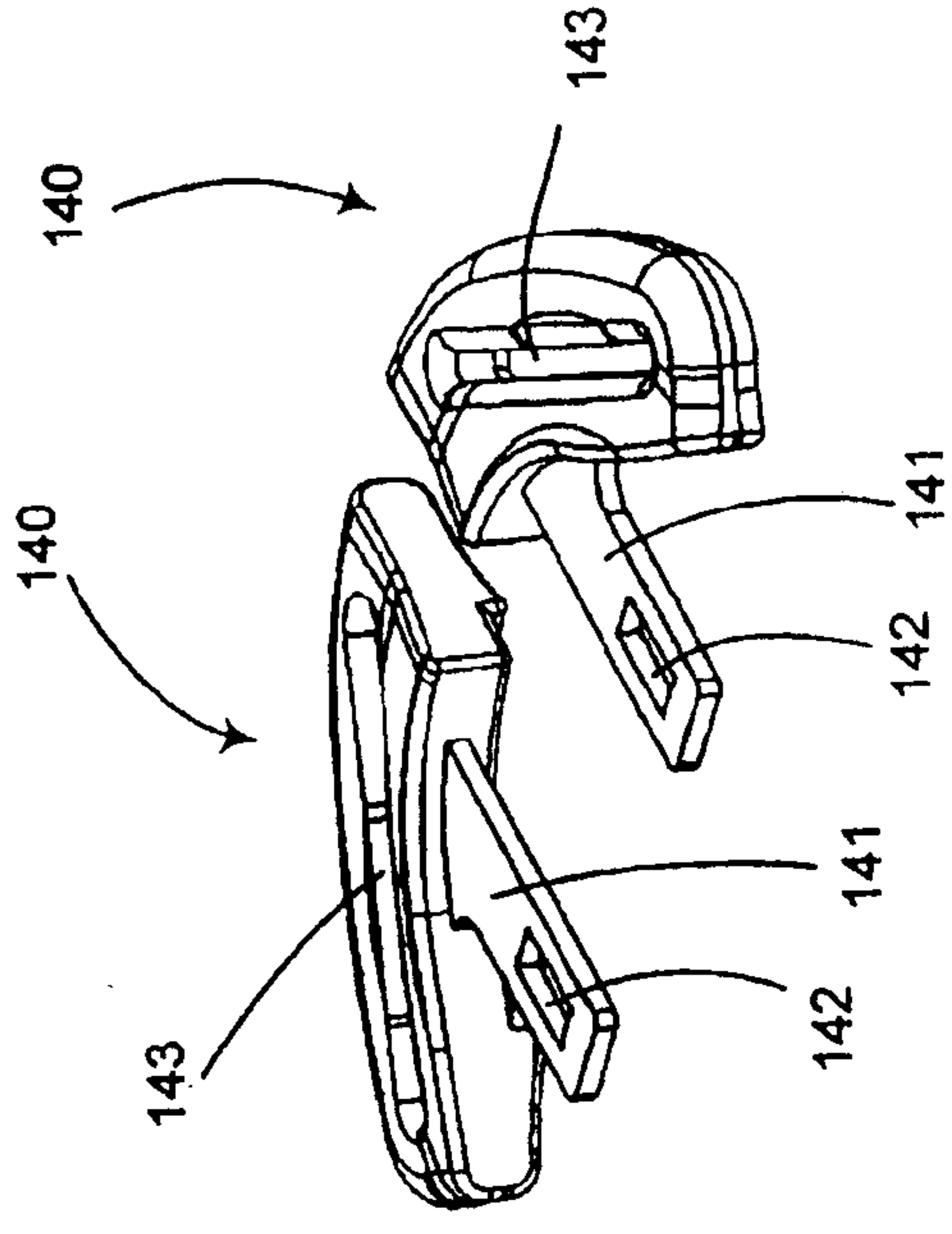

FIG. 6

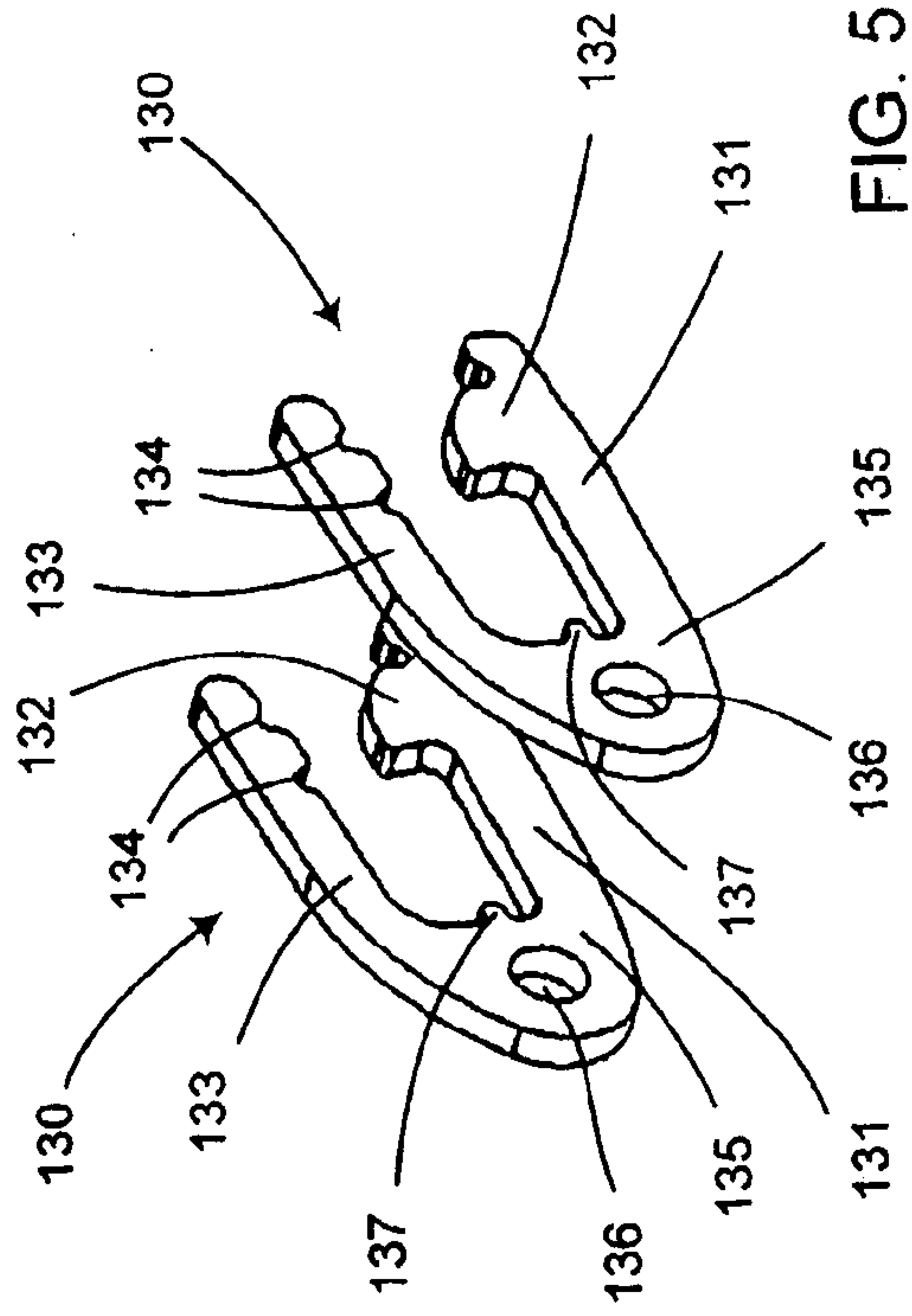

FIG. 5

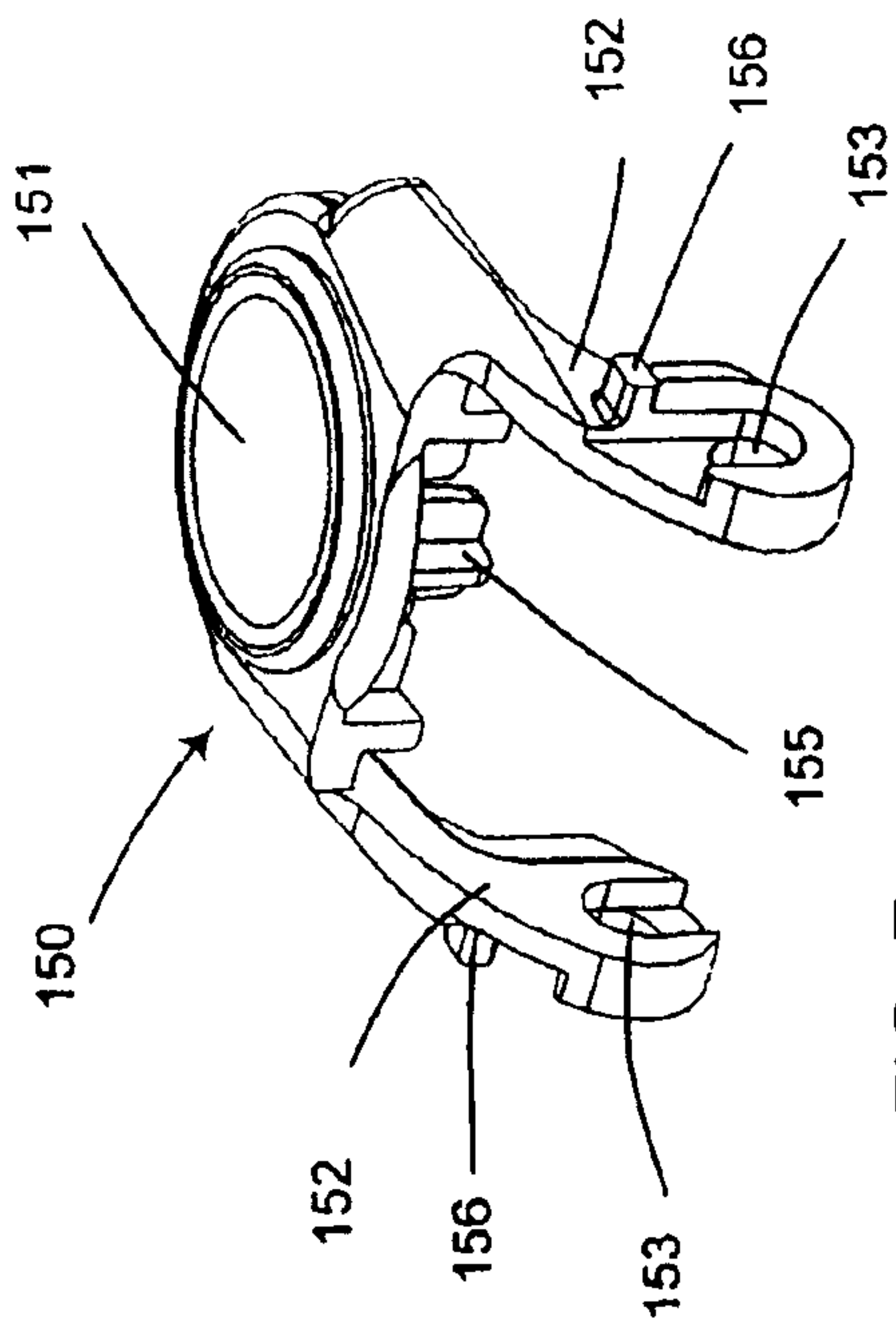

FIG. 7

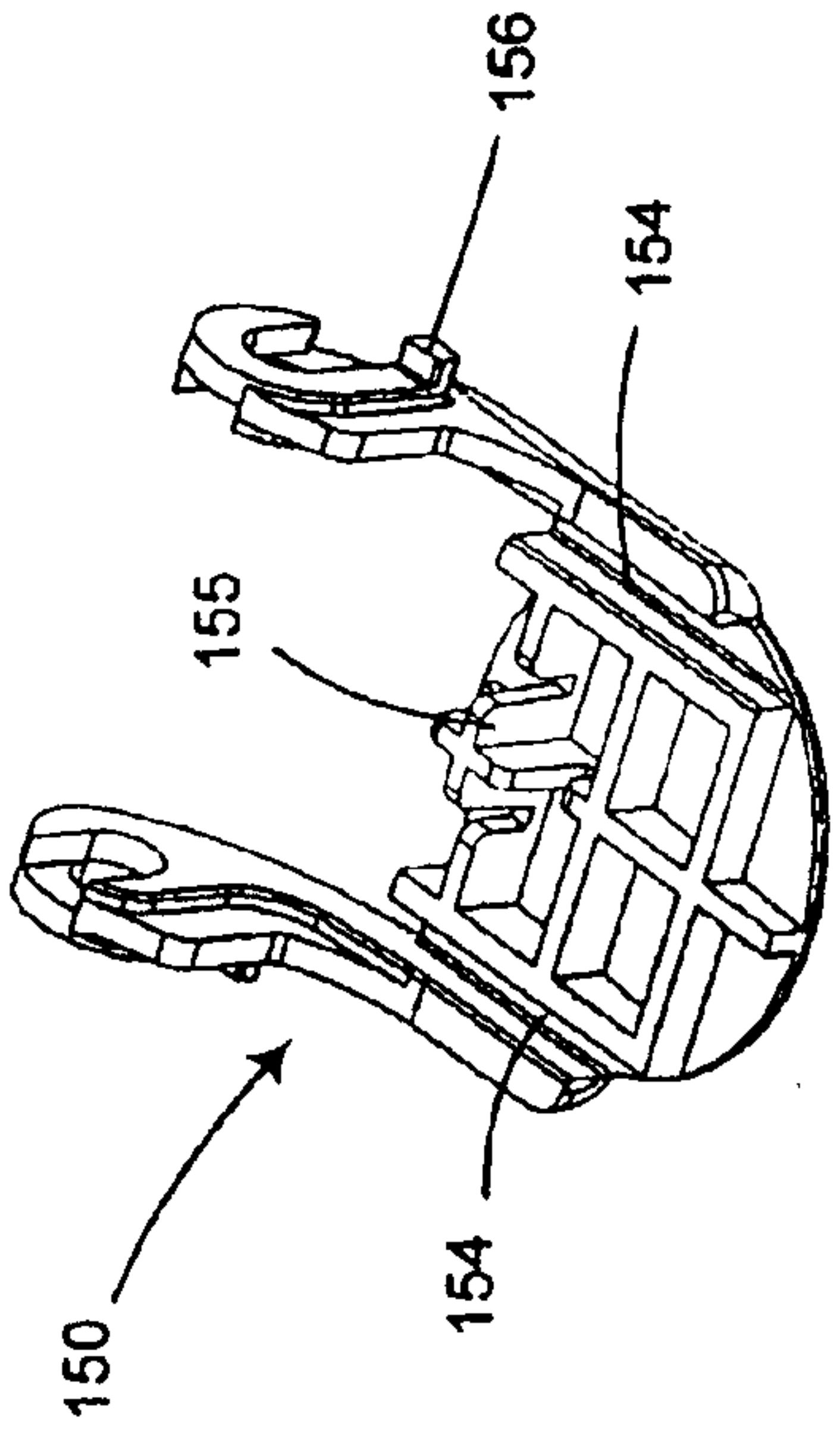

FIG. 8

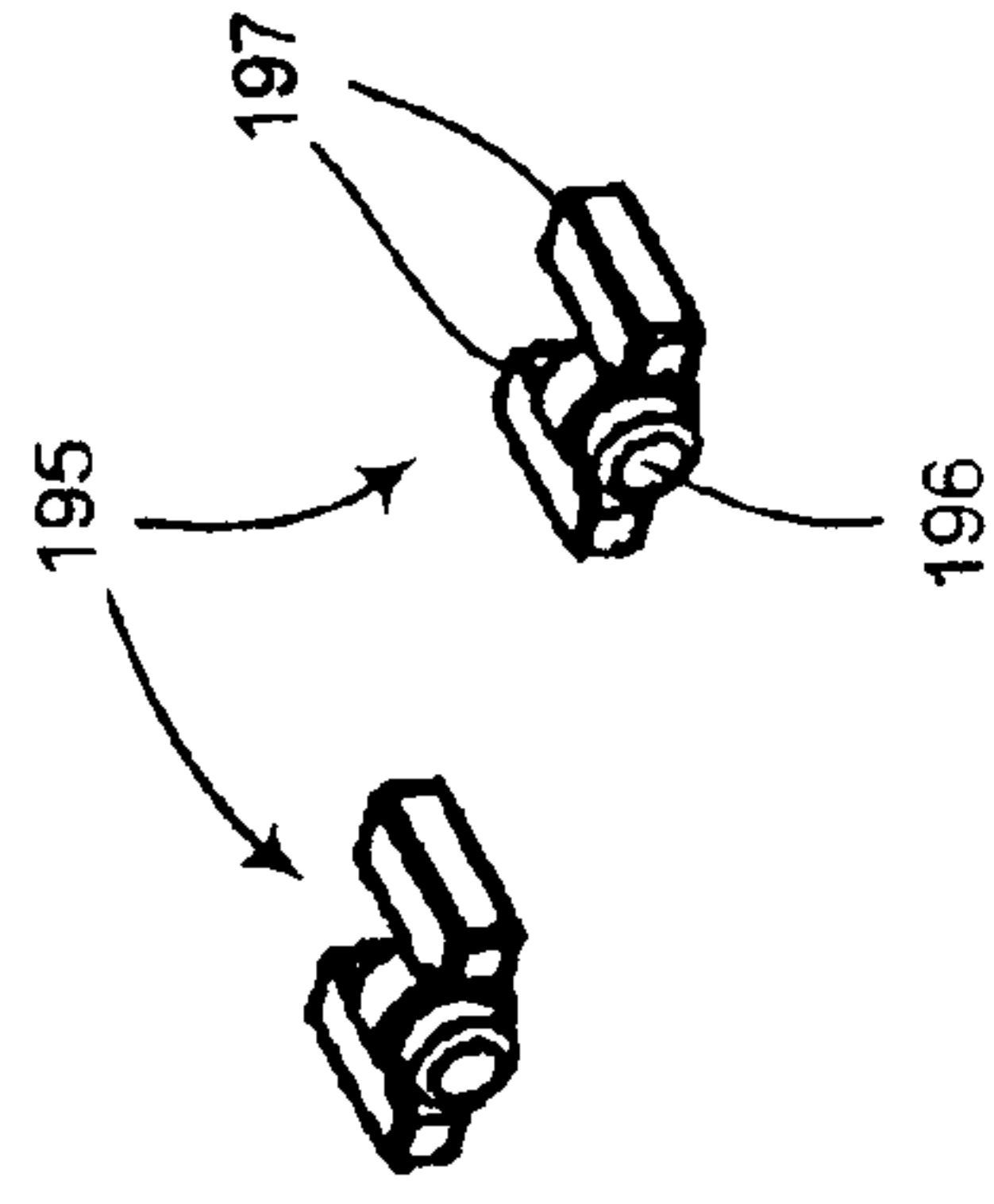

FIG. 10

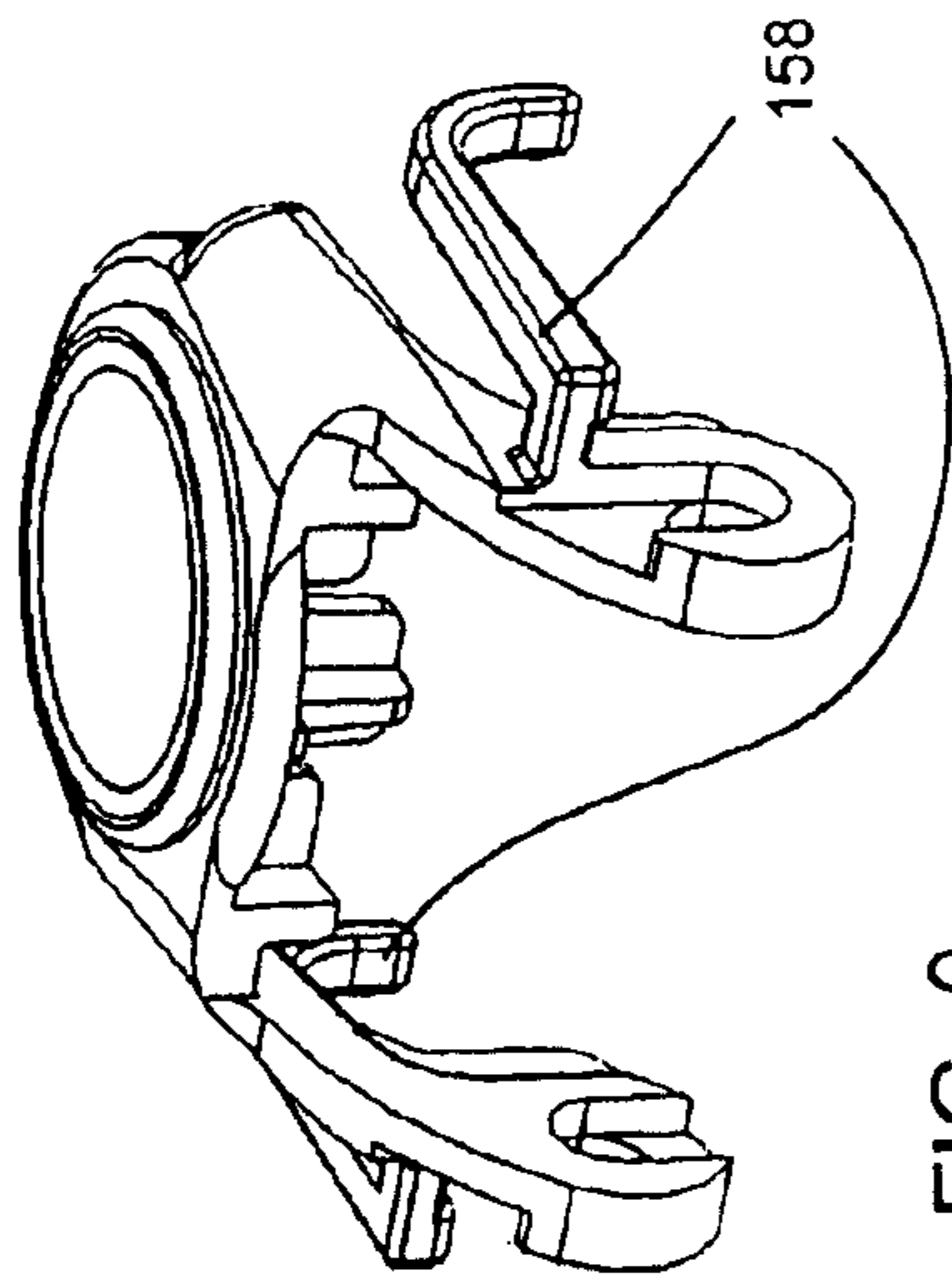

FIG. 9

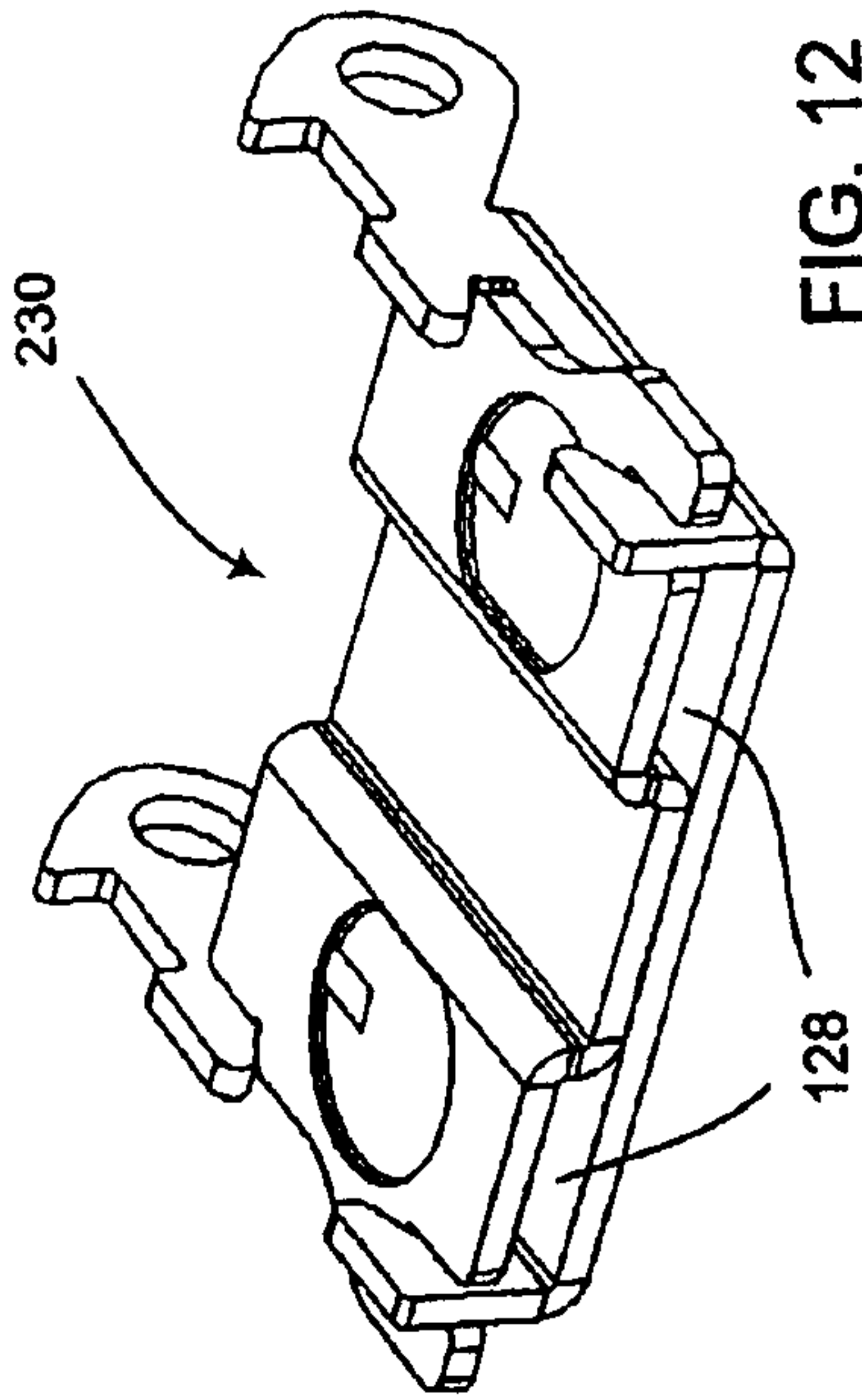

FIG. 12

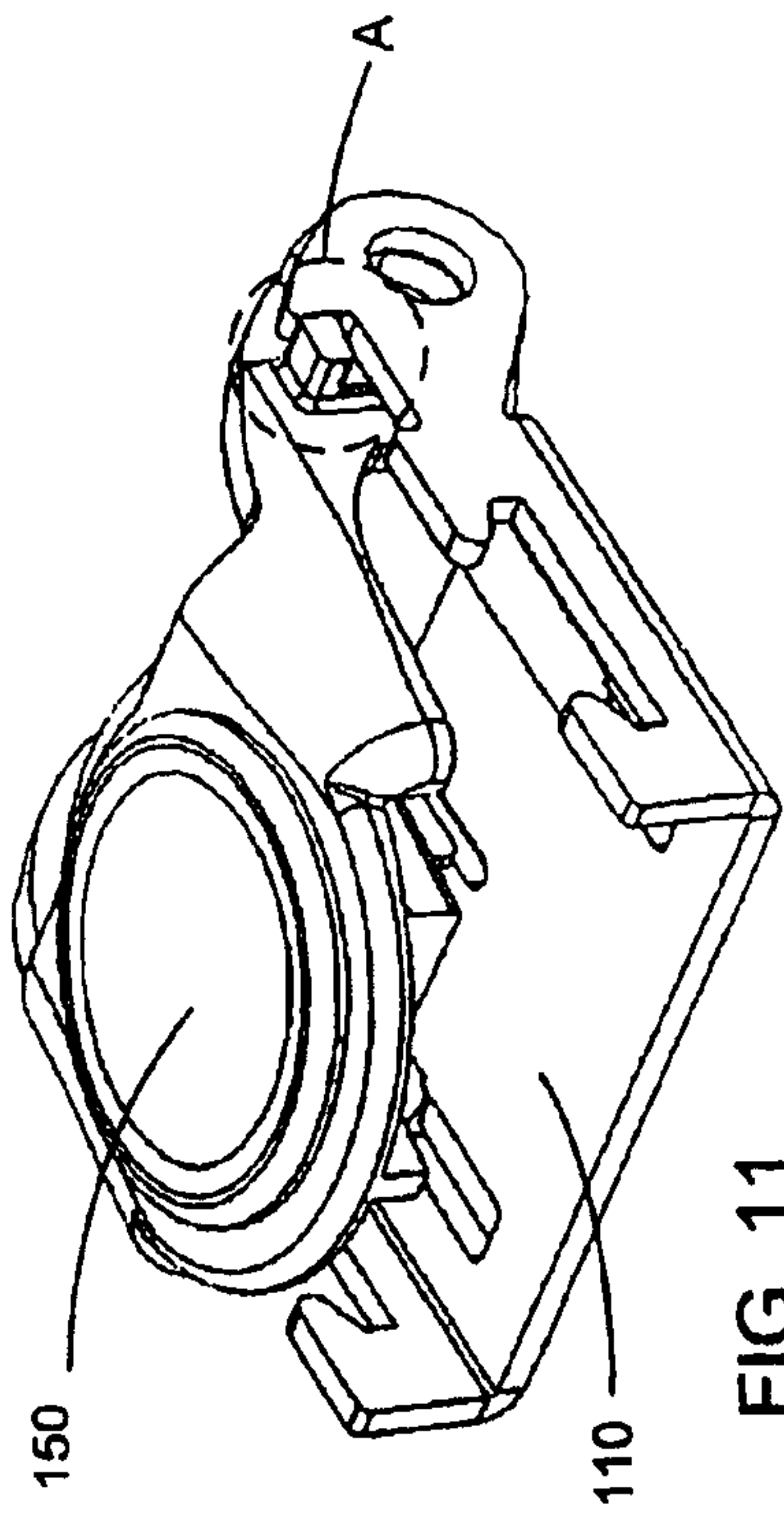

FIG. 11

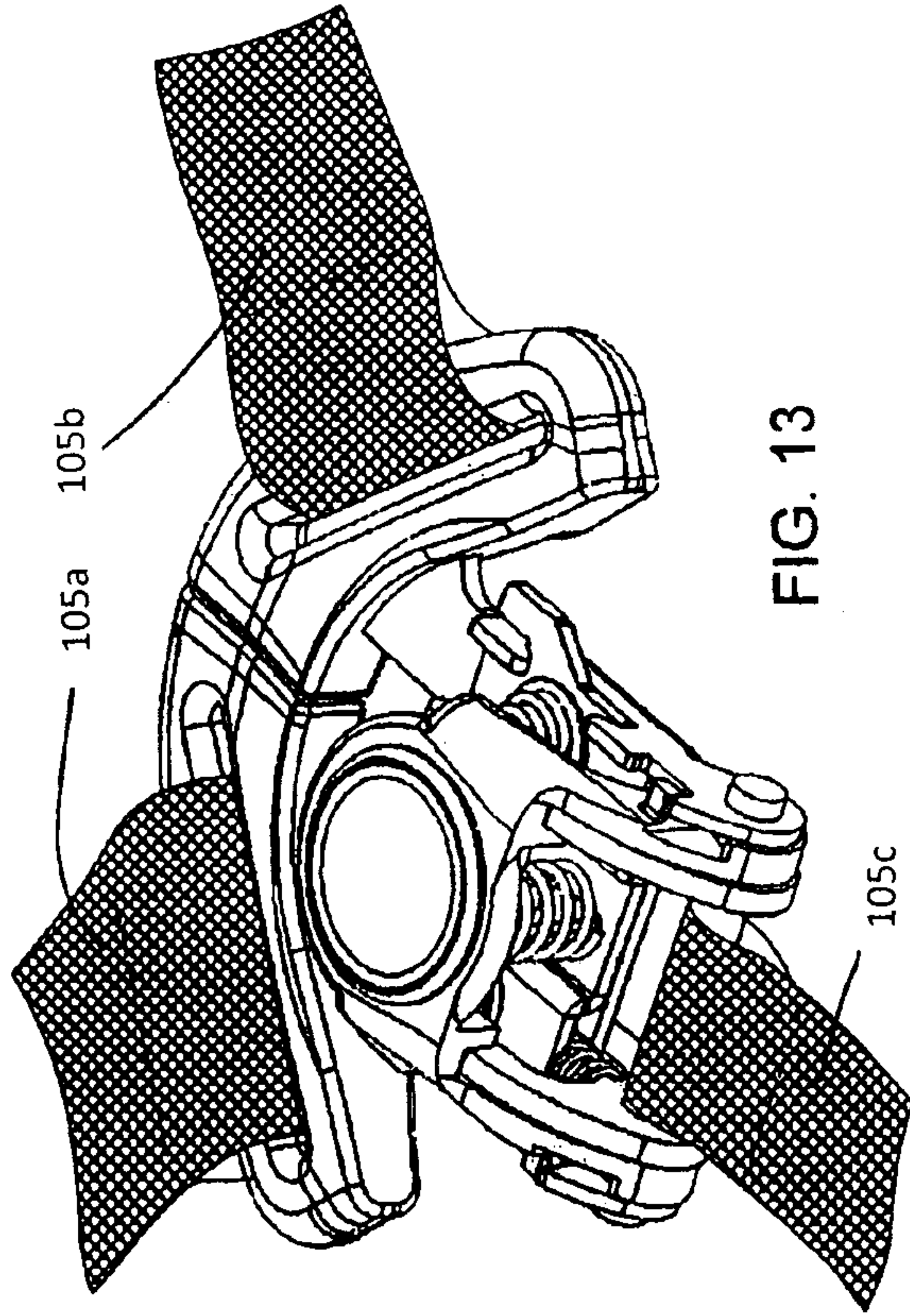

FIG. 13

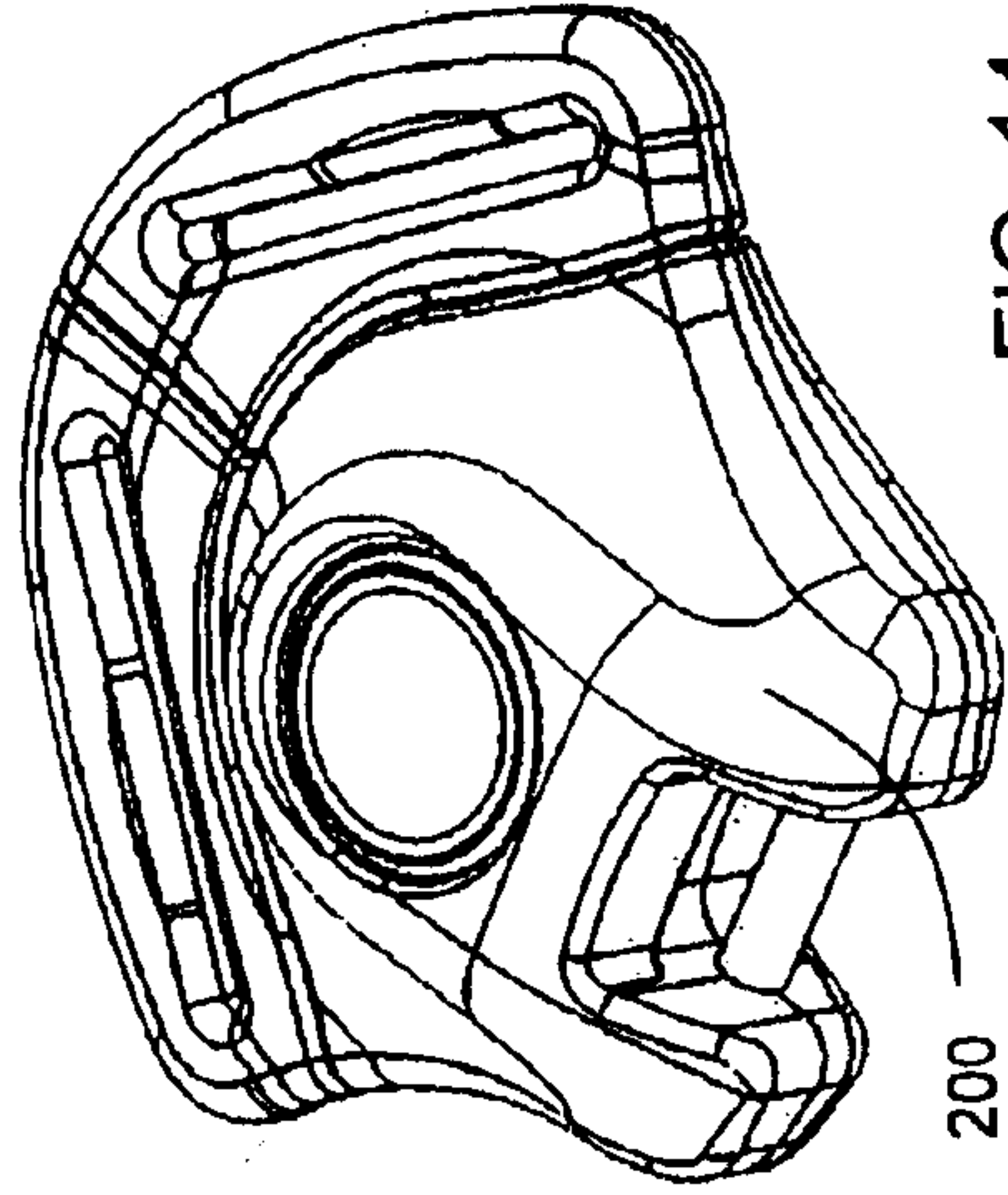

FIG. 14

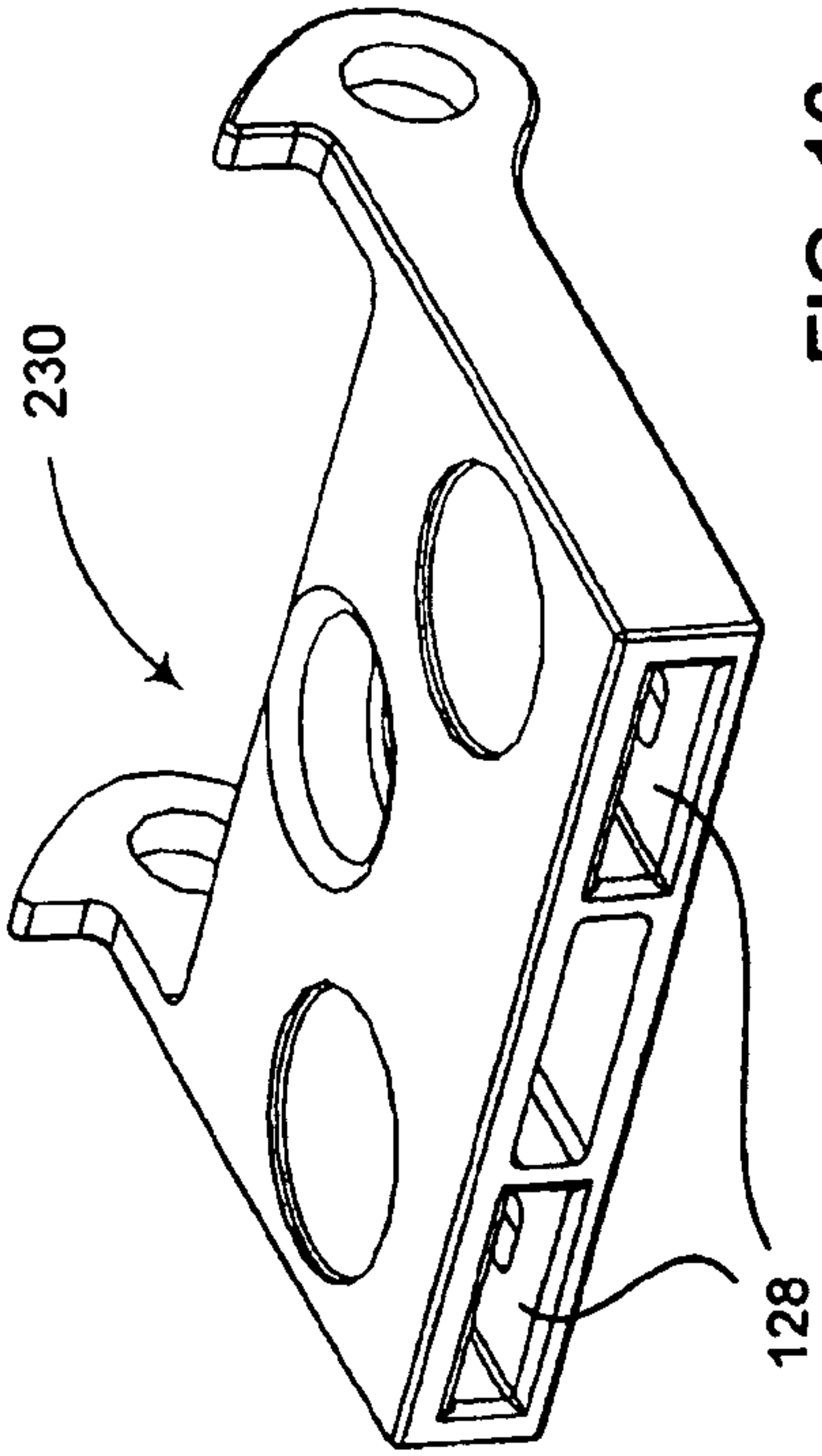

FIG. 16

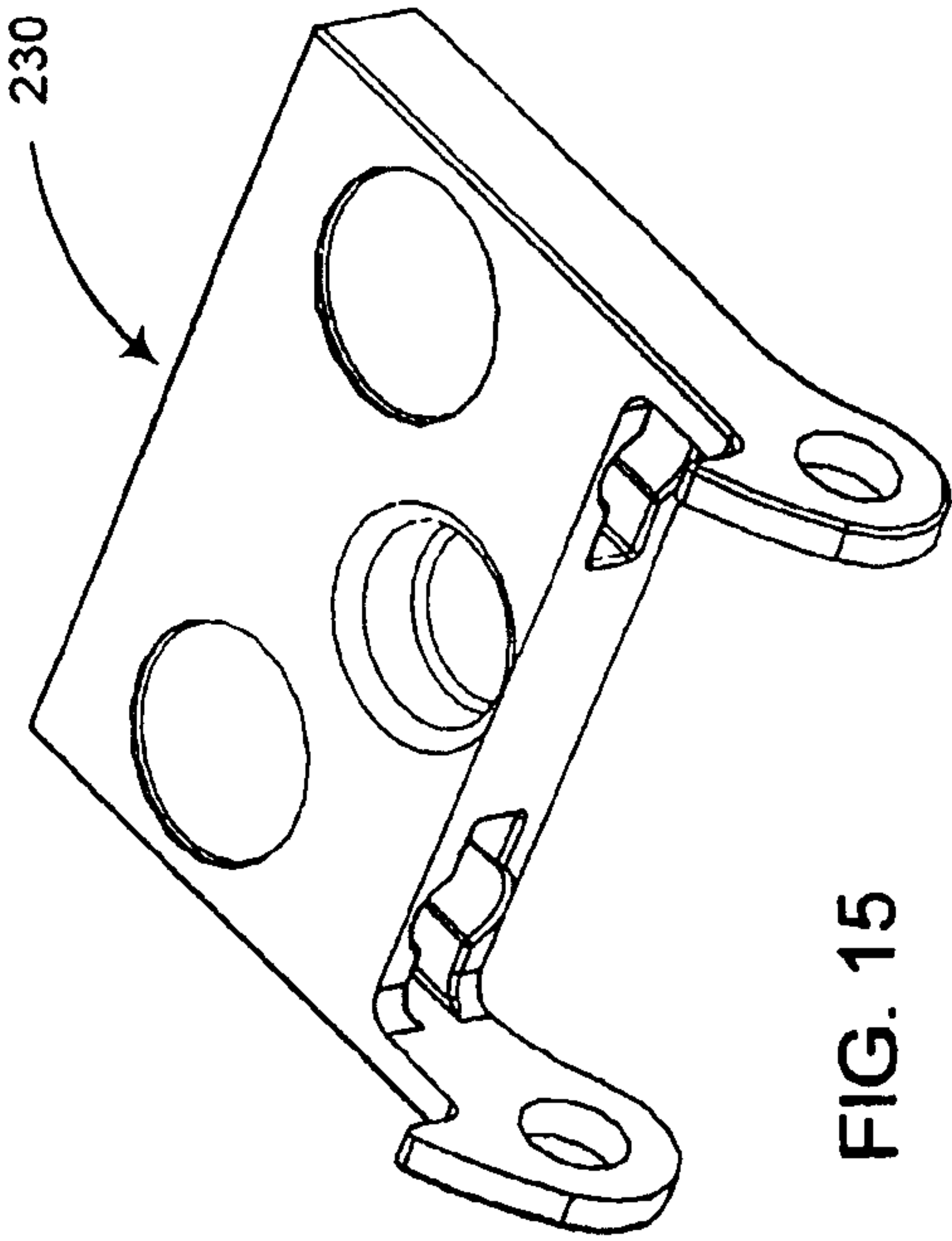

FIG. 15

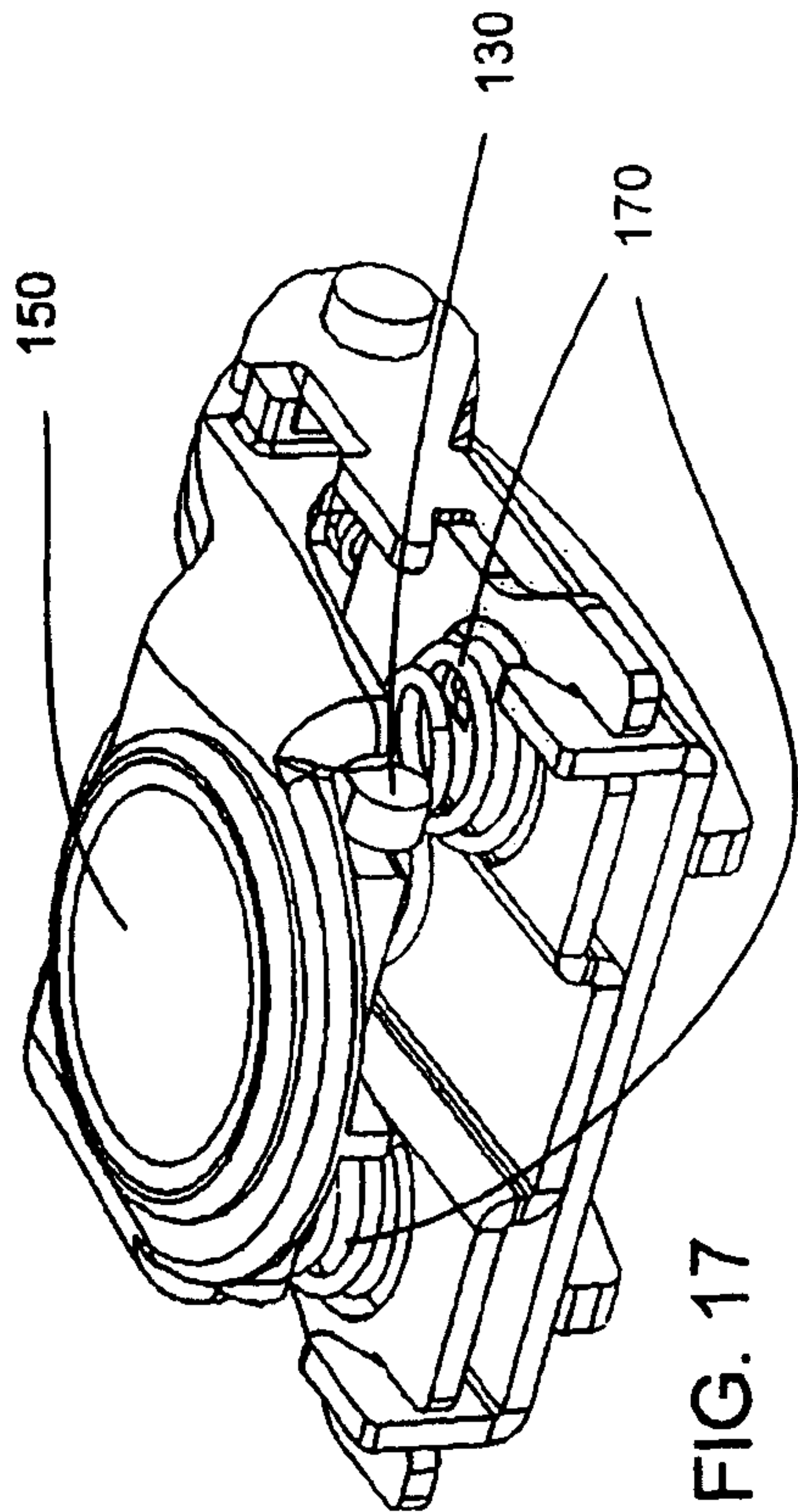

FIG. 17

