



US011680635B2

(12) **United States Patent**  
**Olason**

(10) **Patent No.:** **US 11,680,635 B2**

(45) **Date of Patent:** **Jun. 20, 2023**

(54) **CONTINUOUSLY VARIABLE TRANSMISSION FOR RECREATIONAL VEHICLES AND RELATED COMPONENTS**

(71) Applicant: **Arctic Cat Inc.**, Thief River Falls, MN (US)

(72) Inventor: **Kyle Douglas Olason**, Thief River Falls, MN (US)

(73) Assignee: **ARCTIC CAT INC.**, Thief River Falls, MN (US)

(\* ) Notice: Subject to any disclaimer, the term of this patent is extended or adjusted under 35 U.S.C. 154(b) by 258 days.

(21) Appl. No.: **16/893,752**

(22) Filed: **Jun. 5, 2020**

(65) **Prior Publication Data**  
US 2021/0262562 A1 Aug. 26, 2021

**Related U.S. Application Data**  
(60) Provisional application No. 62/981,090, filed on Feb. 25, 2020.

(51) **Int. Cl.**  
**F16H 55/56** (2006.01)  
**F16H 63/06** (2006.01)  
**B62M 27/02** (2006.01)

(52) **U.S. Cl.**  
CPC ..... **F16H 55/563** (2013.01); **F16H 63/067** (2013.01); **B62M 27/02** (2013.01)

(58) **Field of Classification Search**  
CPC ..... F16H 55/563; F16H 55/56; F16H 55/52; F16H 63/067

(Continued)

(56) **References Cited**

U.S. PATENT DOCUMENTS

3,733,918 A \* 5/1973 Domaas ..... F16H 55/563 474/14  
3,759,111 A \* 9/1973 Hoff ..... F16H 55/563 474/14

(Continued)

OTHER PUBLICATIONS

Aaen, "High-horsepower Sleds Squeeze Tranny Technology Again", Feeling Pressure/American Snowmobiler Magazine, Mar. 16, 2007, 1-5.

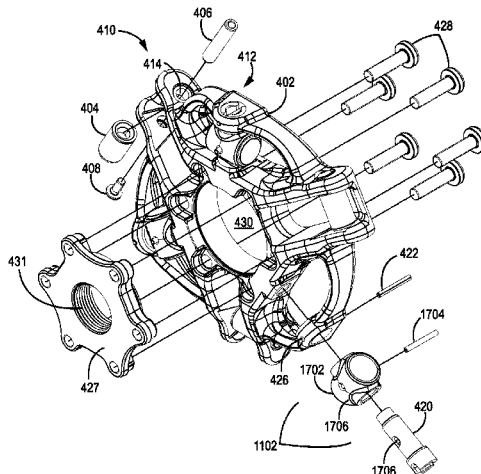
*Primary Examiner* — Henry Y Liu

(74) *Attorney, Agent, or Firm* — Billion & Armitage

(57) **ABSTRACT**

Embodiments of the present disclosure describe a drive pulley for a continuously variable transmission including a stationary shaft, a stationary sheave with a stationary shaft, a movable sheave axially movable relative to the stationary sheave and in contact with the stationary shaft; a spider in contact with at least the moveable sheave and stationary shaft; a spring member, biasing the movable sheave axially away from the stationary sheave; at least one centrifugal actuator including an arm pivotally connected to one of the movable sheave and the spider, the arm pivoting away from the one of the movable sheave and the spider as a speed of rotation of the drive pulley increases, the arm pushing against another one of the movable sheave and the spider as the arm pivots away from the one of the movable sheave and the spider, thereby moving the movable sheave axially toward the stationary sheave, the at least one centrifugal actuator being disposed radially outward of the stationary sheave shaft; and a torque transfer assembly operatively connected to at least one of the spider and the movable sheave, the torque transfer assembly transferring torque between the spider and the movable sheave, the torque transfer assembly including, a torque bearing assembly and at least one roller assembly, positioned on a helixed torque pin, the torque pin connected to the spider; wherein as the roller assembly wears, the at least one

(Continued)



roller assembly tracks along a helixed path of the torque pin in a distal direction from the bearing assembly.

**12 Claims, 93 Drawing Sheets**

(58) **Field of Classification Search**

USPC ..... 474/14  
See application file for complete search history.

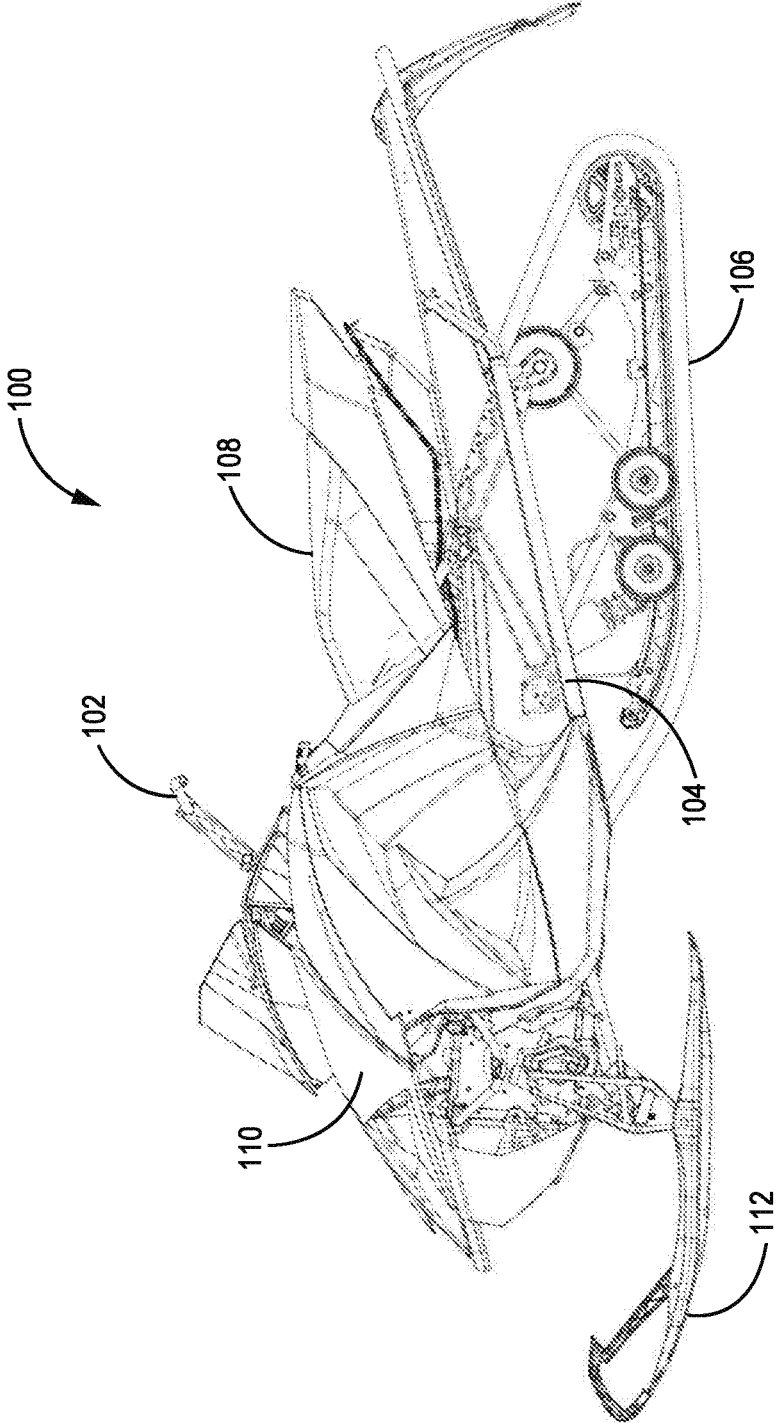
(56) **References Cited**

U.S. PATENT DOCUMENTS

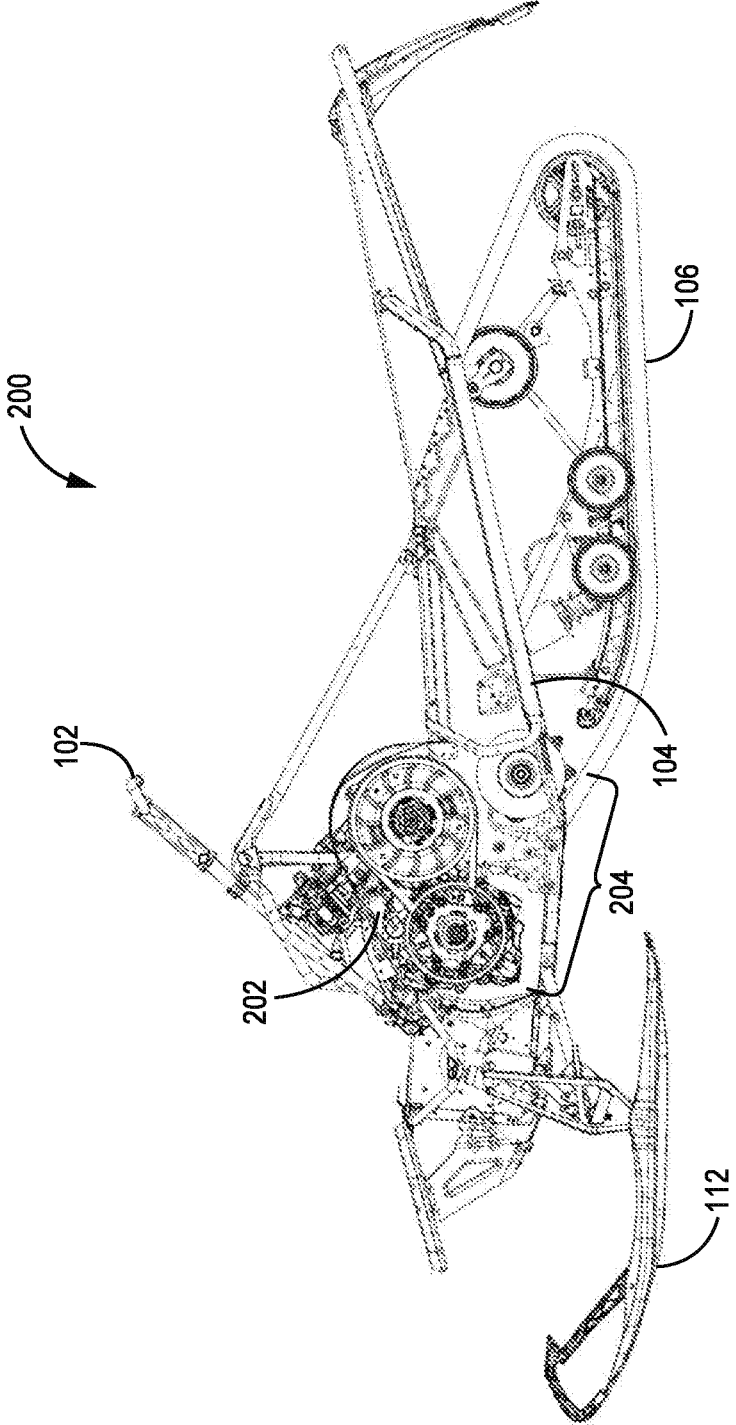
3,777,584 A \* 12/1973 Domaas ..... F16H 61/66245  
474/14  
3,939,720 A \* 2/1976 Aaen ..... F16H 55/563  
474/46  
3,961,539 A \* 6/1976 Tremblay ..... F16H 55/563  
474/46  
4,464,144 A \* 8/1984 Kobayashi ..... F16H 55/563  
474/43  
4,483,686 A \* 11/1984 Kobayashi ..... F16H 55/563  
474/93  
4,575,363 A \* 3/1986 Burgess ..... F16H 55/563  
474/14  
5,209,703 A \* 5/1993 Mastine ..... F16H 55/563  
474/70  
5,326,330 A \* 7/1994 Bostelmann ..... F16H 55/563  
474/14  
5,421,784 A \* 6/1995 Robert ..... F16H 55/563  
474/13  
5,529,544 A \* 6/1996 Berto ..... F16H 61/66245  
474/11  
5,597,060 A \* 1/1997 Huddleston ..... F16H 55/563  
474/14  
5,647,810 A \* 7/1997 Huddleston ..... F16H 55/563  
384/126  
6,120,399 A \* 9/2000 Okeson ..... F16H 55/56  
474/14  
6,309,317 B1 \* 10/2001 Joss ..... F16D 43/06  
474/14

6,334,826 B1 \* 1/2002 Takagi ..... F16H 55/563  
474/14  
6,569,043 B2 \* 5/2003 Younggren ..... F16H 55/56  
474/19  
6,743,129 B1 \* 6/2004 Younggren ..... F16H 55/56  
474/19  
7,726,927 B2 \* 6/2010 Cook ..... F16B 3/005  
411/398  
8,496,551 B2 \* 7/2013 Mueller ..... F16H 63/067  
474/17  
8,668,623 B2 \* 3/2014 Vuksa ..... F16H 63/067  
477/80  
9,500,264 B2 \* 11/2016 Aitcin ..... F16H 9/14  
10,066,729 B2 \* 9/2018 Aitcin ..... F16H 55/36  
10,174,827 B2 \* 1/2019 Eck ..... F16H 9/14  
10,767,745 B2 \* 9/2020 Zauner ..... F16H 55/563  
11,306,809 B2 \* 4/2022 Aitcin ..... B62M 27/02  
11,339,866 B2 \* 5/2022 Eck ..... F16H 55/56  
2002/0123400 A1 \* 9/2002 Younggren ..... F16H 61/66272  
474/14  
2004/0214668 A1 \* 10/2004 Takano ..... F16H 63/067  
474/14  
2009/0227404 A1 \* 9/2009 Beyer ..... F16H 55/563  
474/14  
2013/0157794 A1 \* 6/2013 Stegelmann ..... F16H 63/067  
474/8  
2013/0288833 A1 10/2013 Mueller et al.  
2013/0294856 A1 11/2013 Mueller et al.  
2014/0235382 A1 \* 8/2014 Tsukamoto ..... F16H 63/067  
474/14  
2016/0069434 A1 \* 3/2016 Aitcin ..... B62M 9/08  
180/54.1  
2016/0160989 A1 \* 6/2016 Millard ..... F16H 55/563  
474/14  
2017/0030454 A1 \* 2/2017 Aitcin ..... F16H 9/14  
2018/0037212 A1 \* 2/2018 Beyer ..... F16H 55/566  
2018/0080554 A1 \* 3/2018 Simpson ..... F16H 55/566  
2018/0202533 A1 \* 7/2018 Zauner ..... F16H 9/18  
2018/0363748 A1 \* 12/2018 Okeson ..... F16H 15/52  
2019/0063582 A1 \* 2/2019 Aitcin ..... F16H 55/563  
2020/0166115 A1 \* 5/2020 Aitcin ..... F16H 9/18

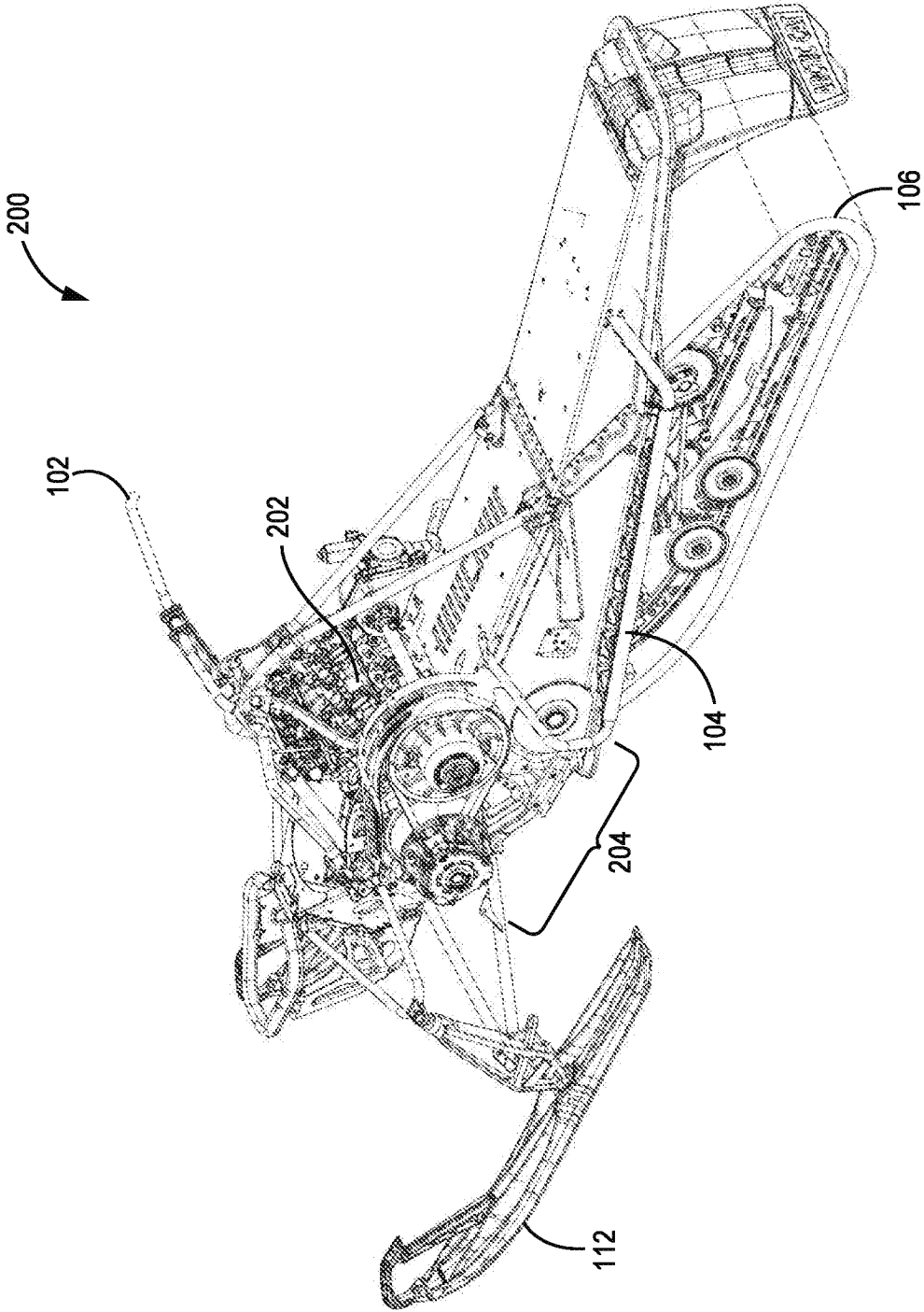
\* cited by examiner



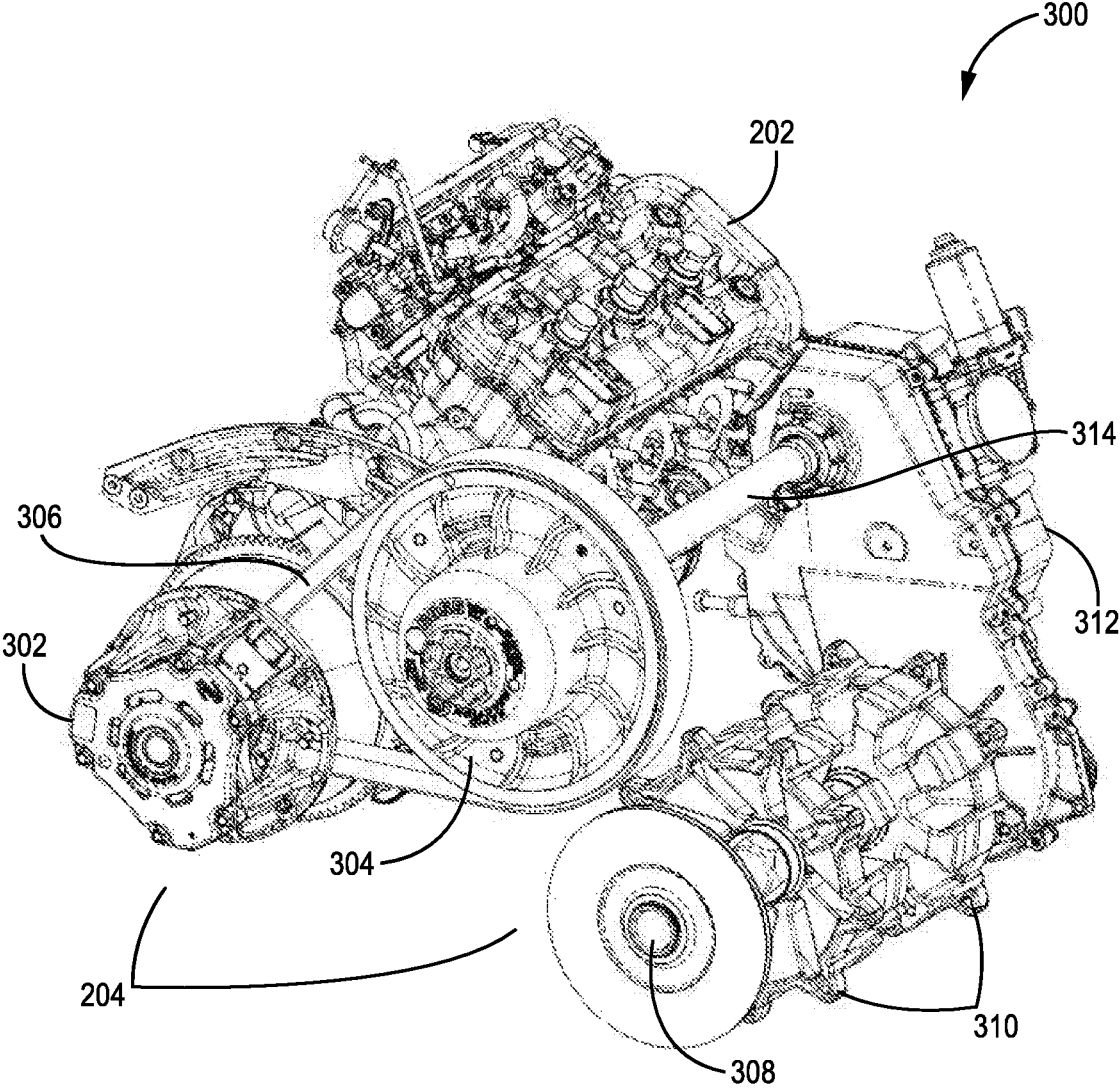
**FIG. 1**



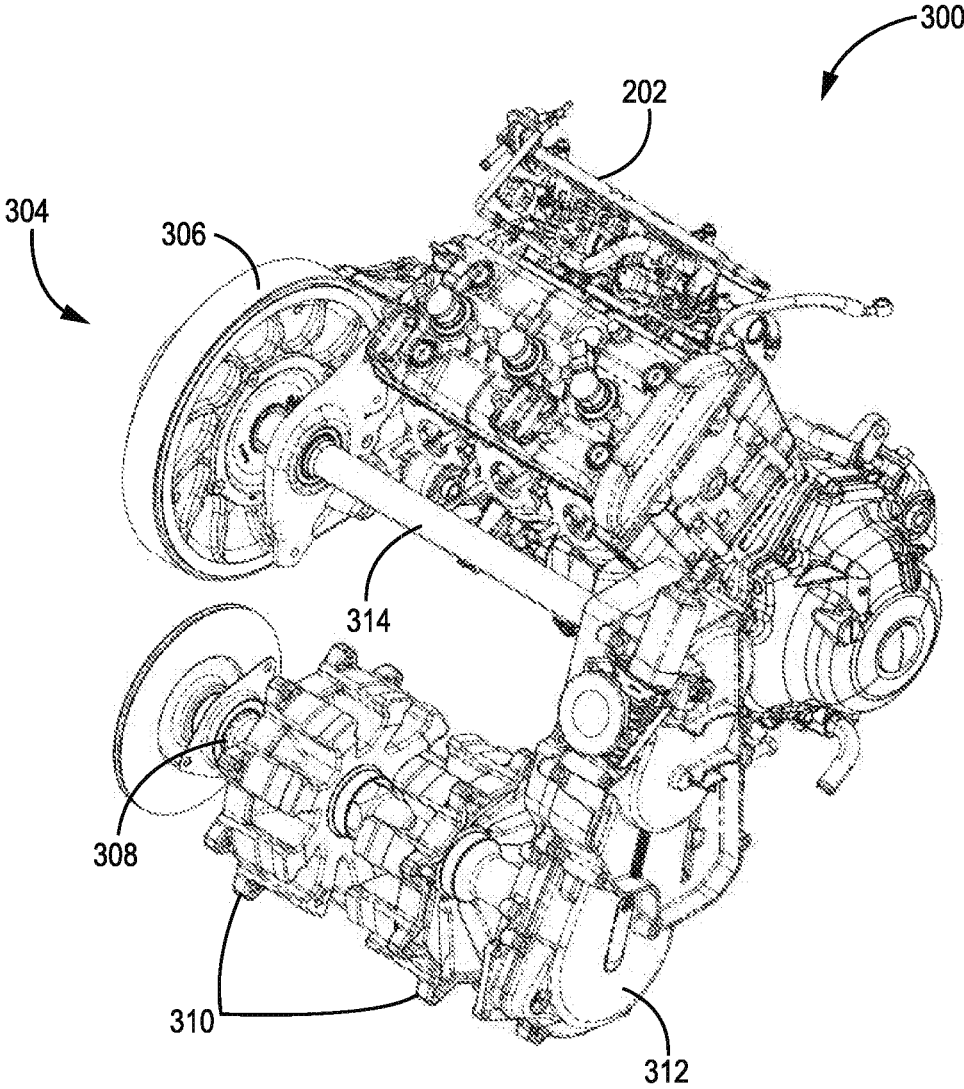
**FIG. 2A**



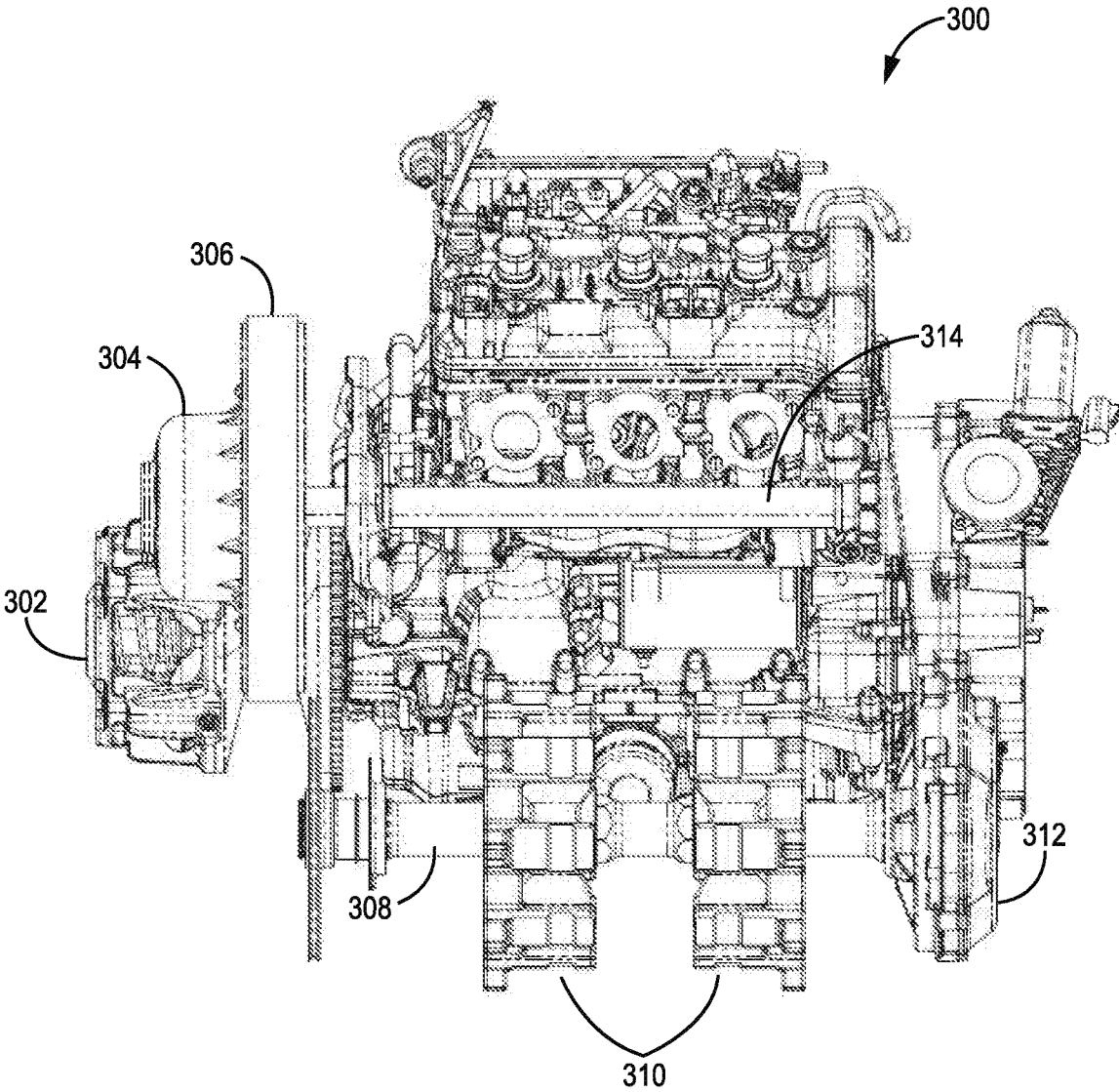
**FIG. 2B**



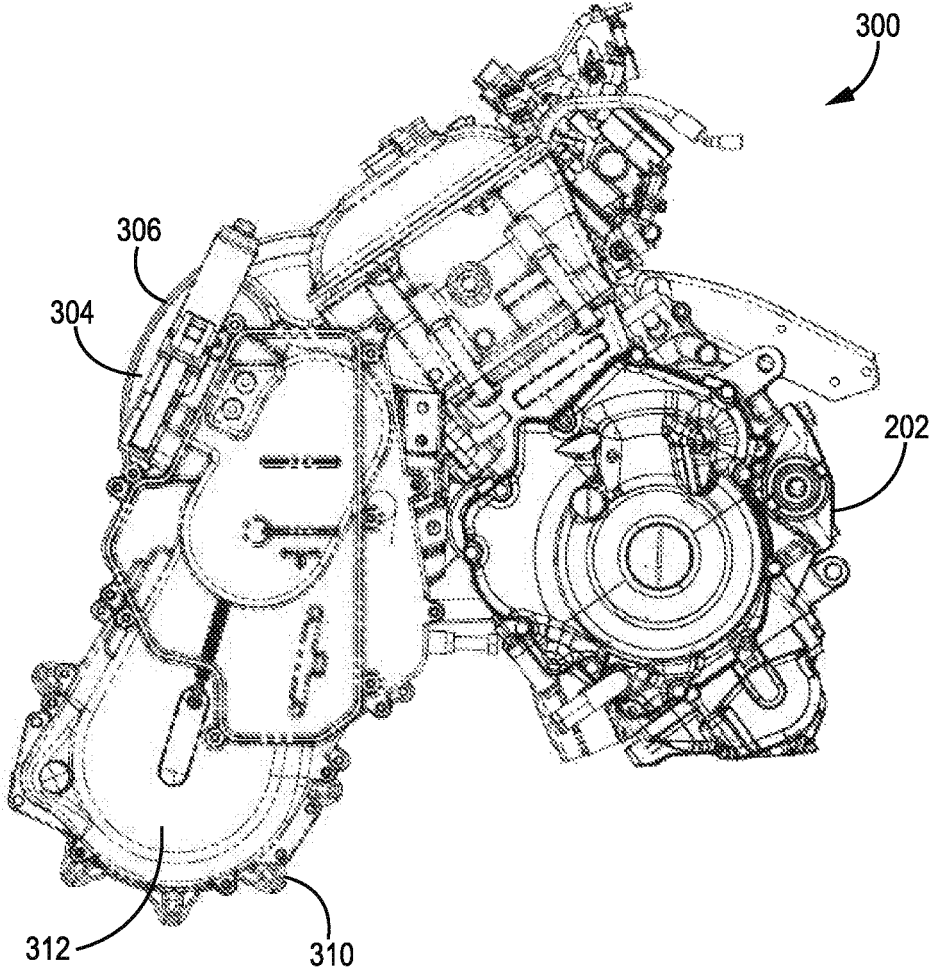
**FIG. 3A**



**FIG. 3B**



**FIG. 3C**



**FIG. 3D**

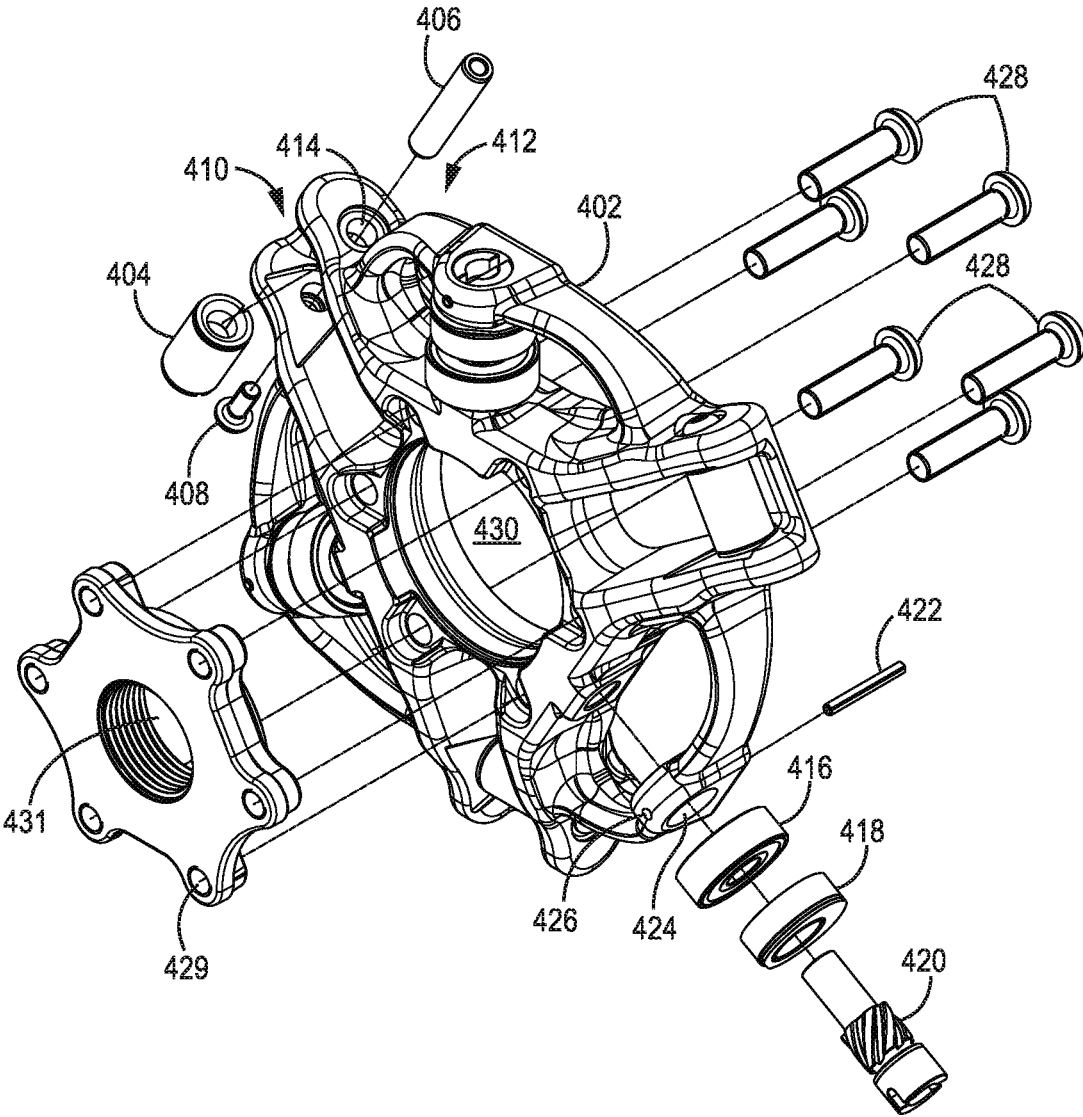
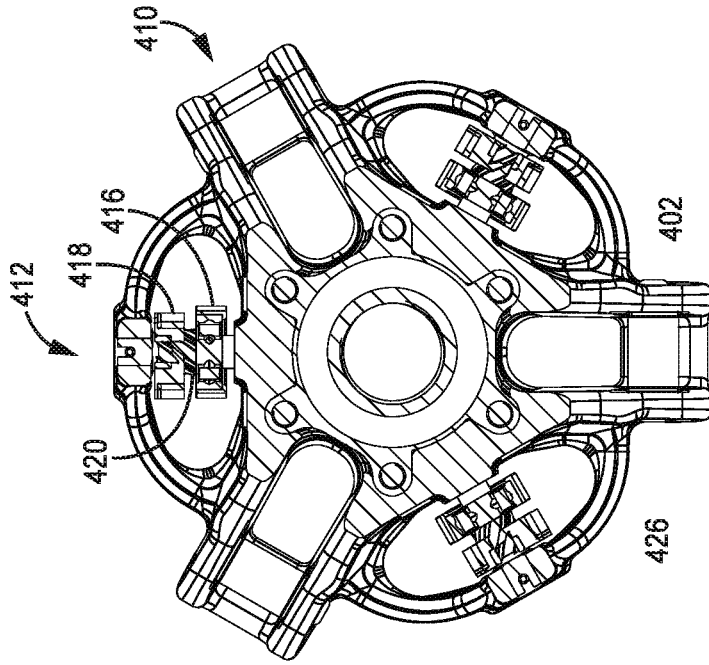
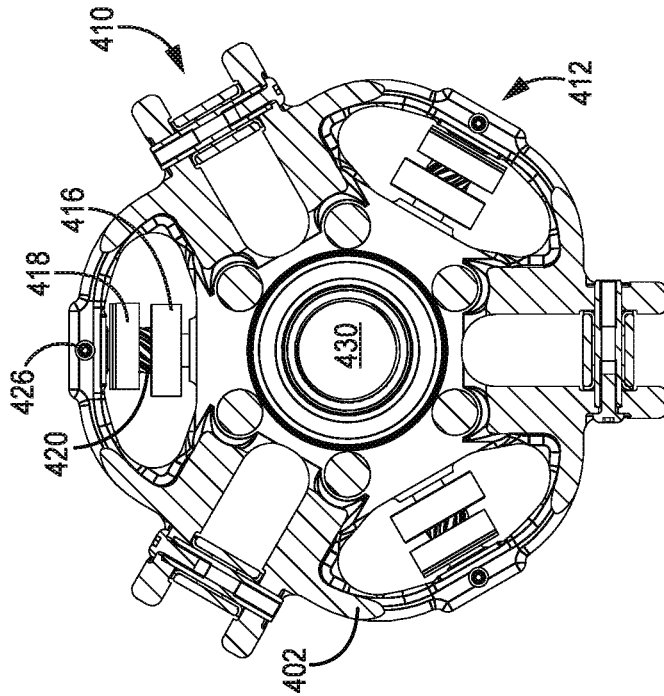


FIG. 4A



SECTION B-B

FIG. 4D



SECTION A-A

FIG. 4C

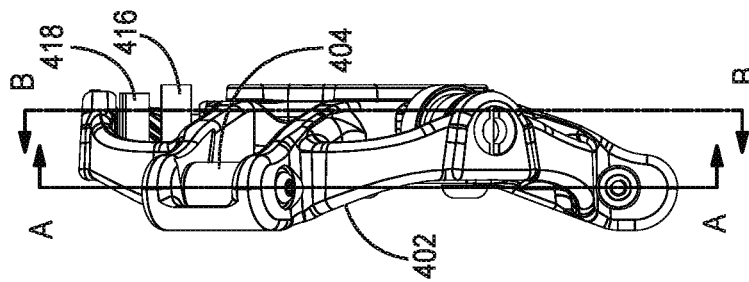


FIG. 4B

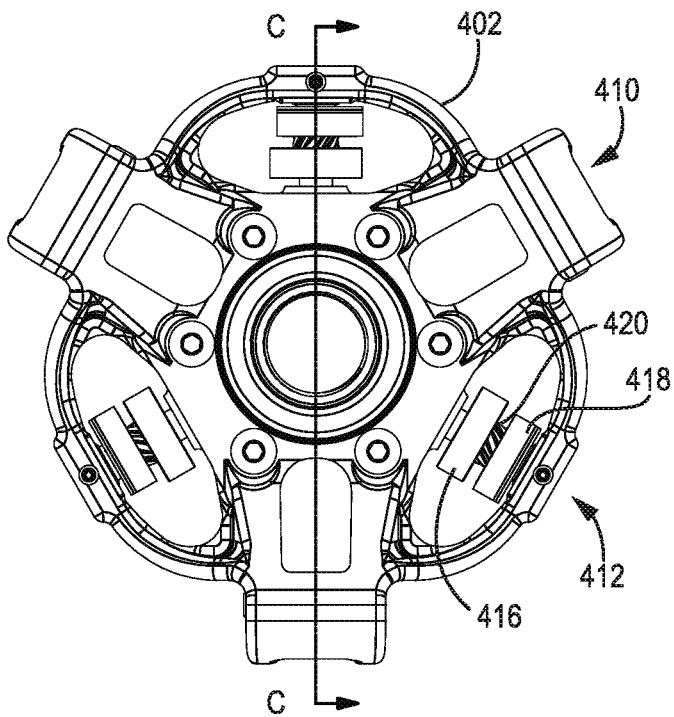
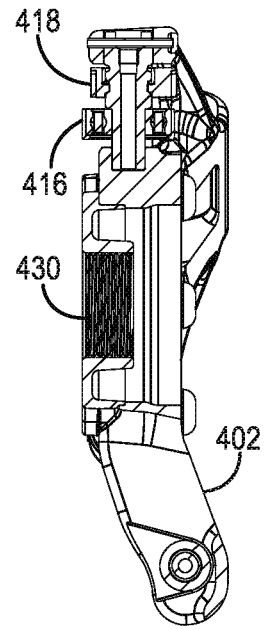
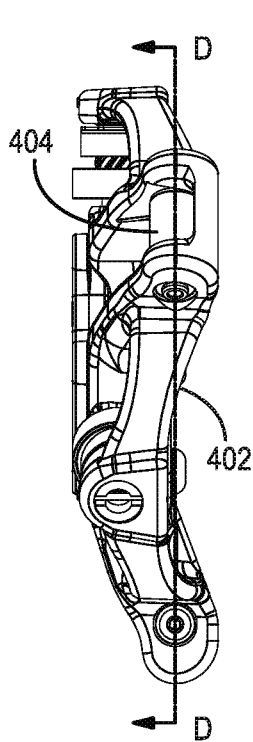


FIG. 4E

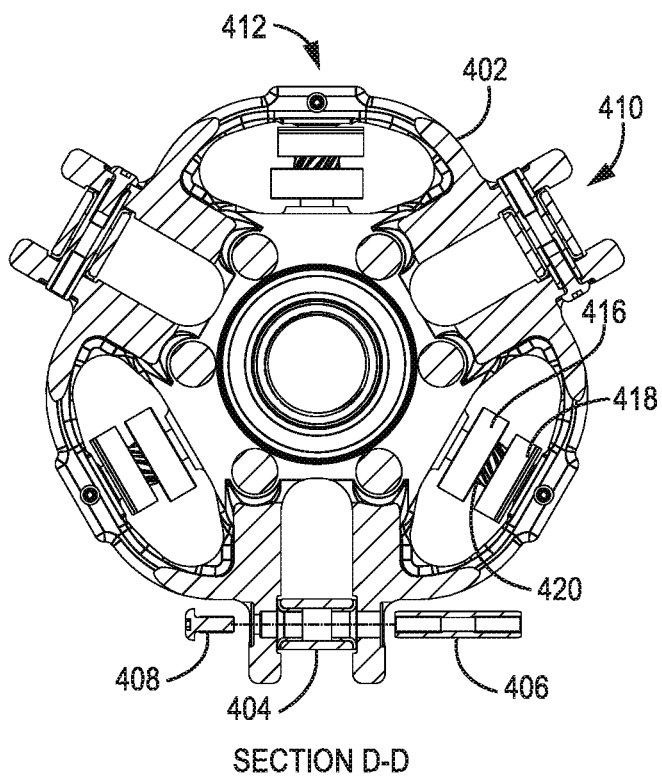


SECTION C-C

FIG. 4F



**FIG. 4G**



**FIG. 4H**

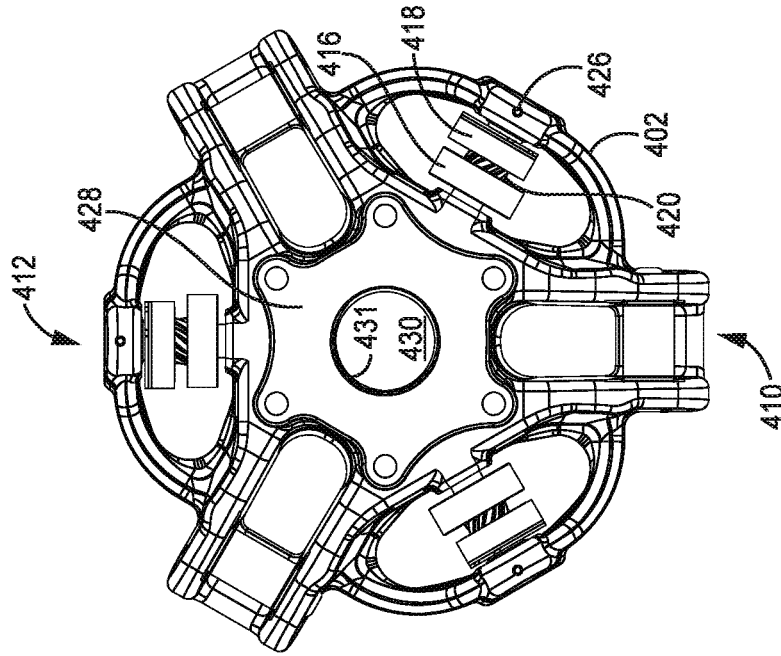


FIG. 4J

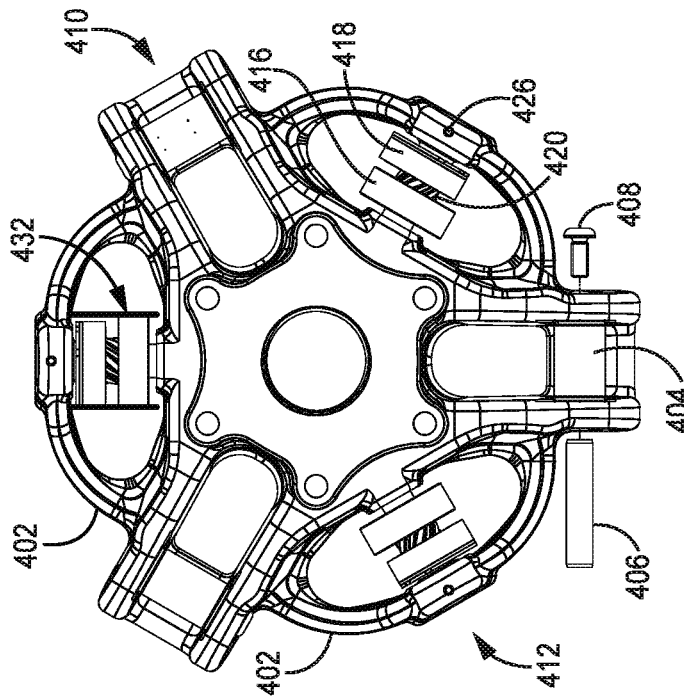


FIG. 4I

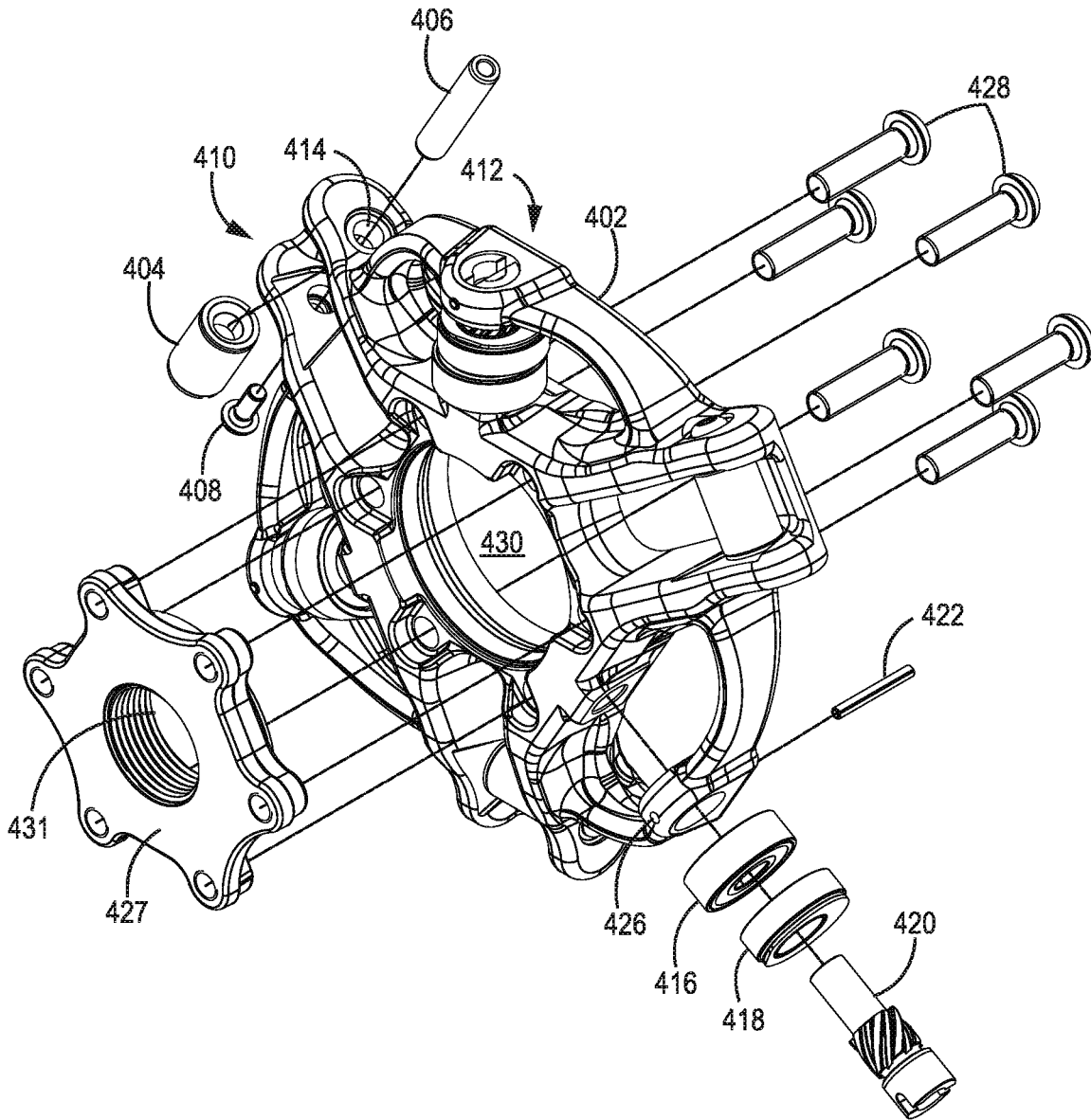
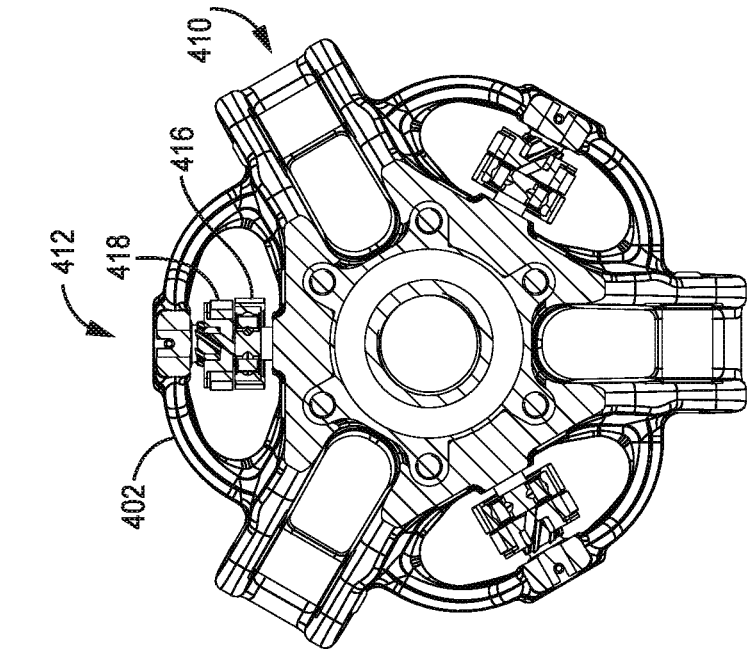
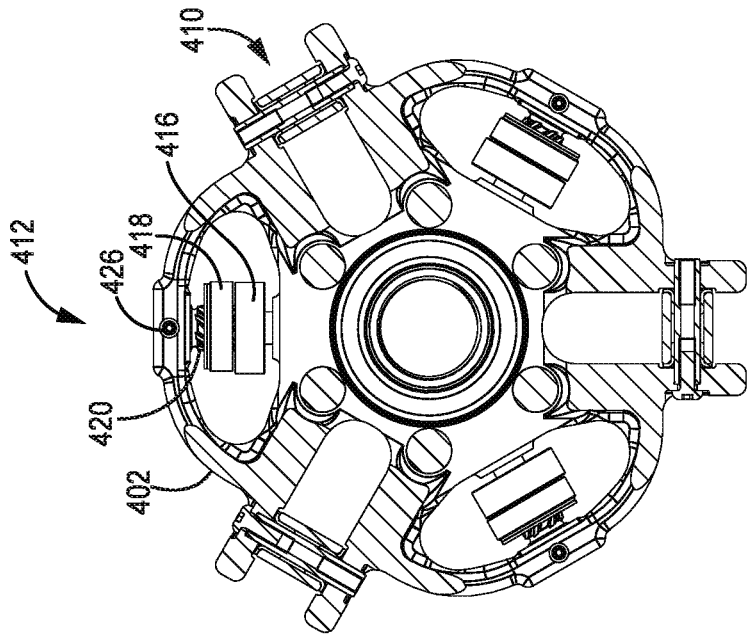


FIG. 5A



SECTION B-B

FIG. 5D



SECTION A-A

FIG. 5C

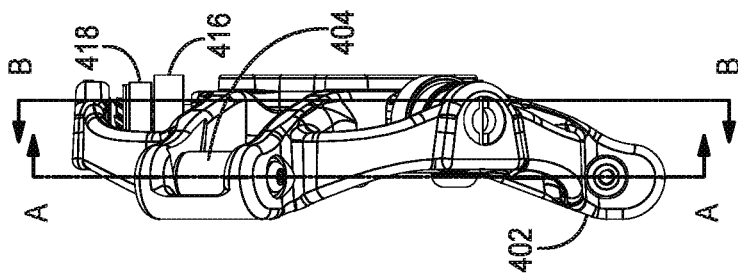


FIG. 5B

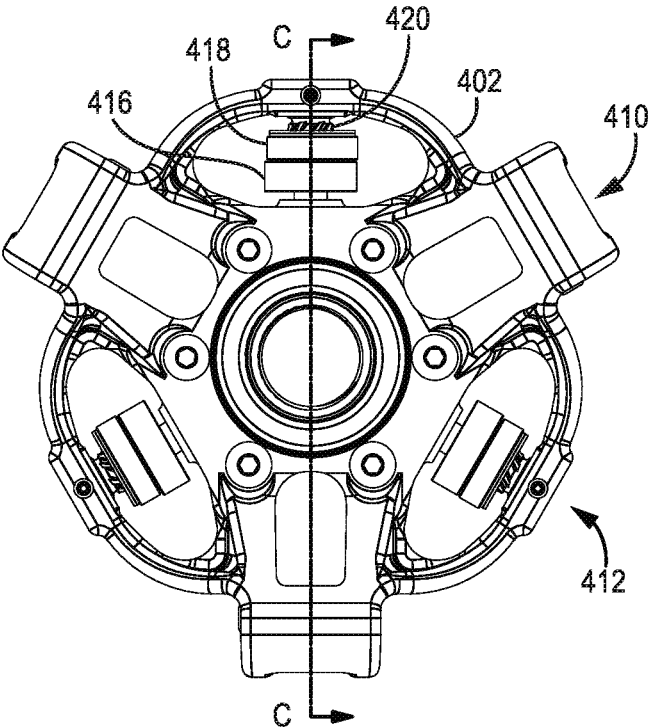
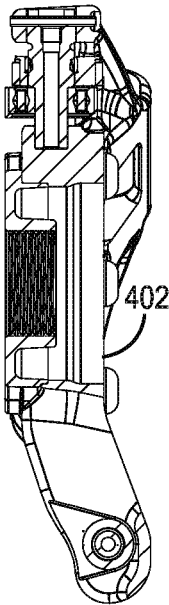
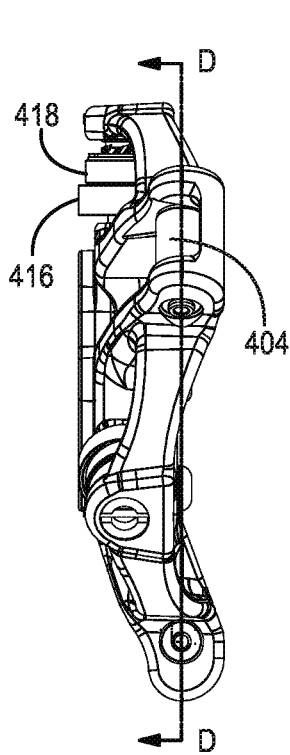


FIG. 5E

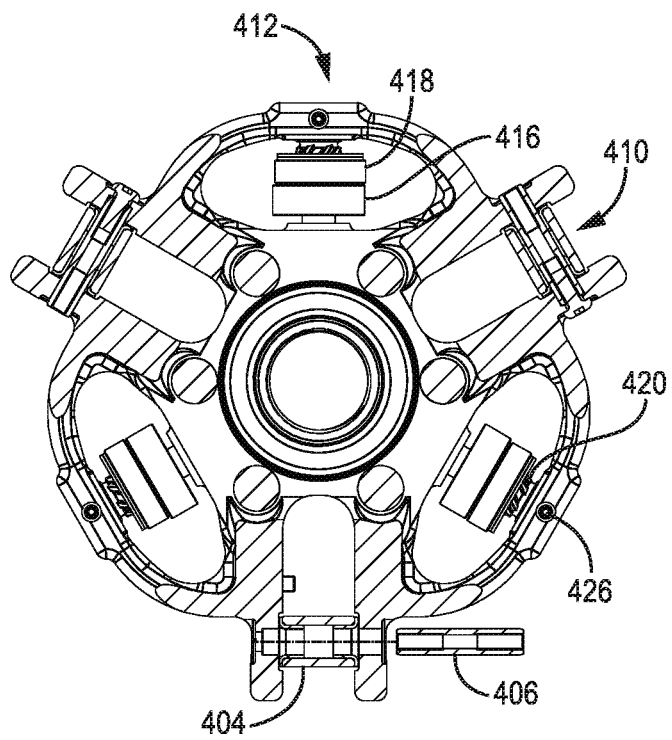


SECTION C-C

FIG. 5F



**FIG. 5G**



SECTION D-D

**FIG. 5H**

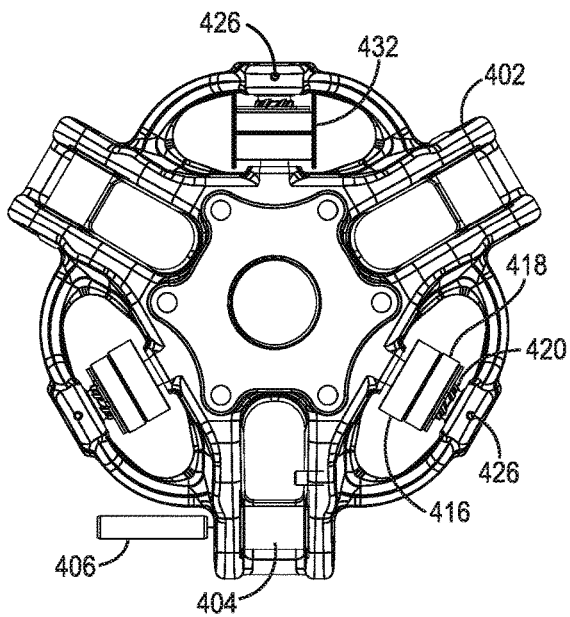


FIG. 5I

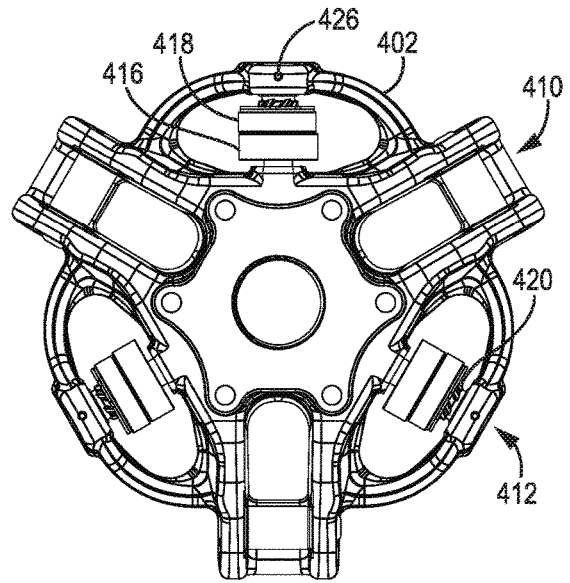


FIG. 5J

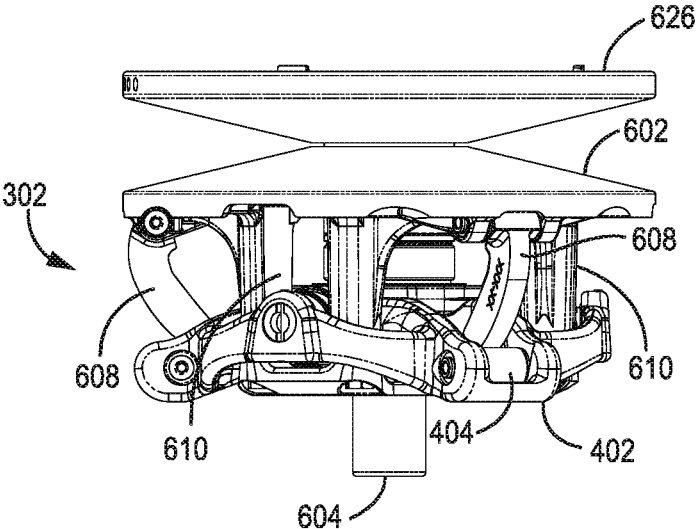


FIG. 6A

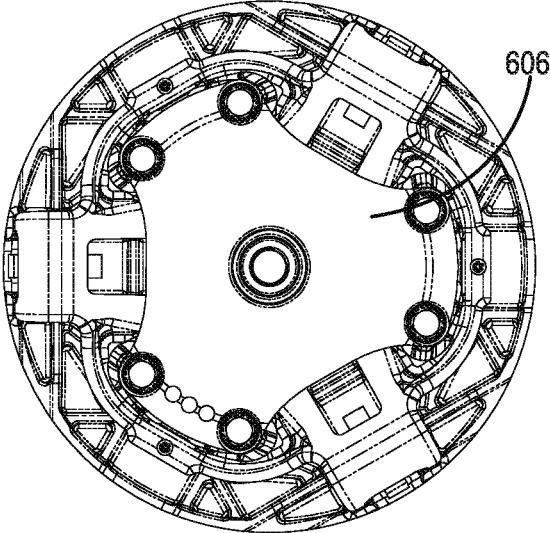


FIG. 6B

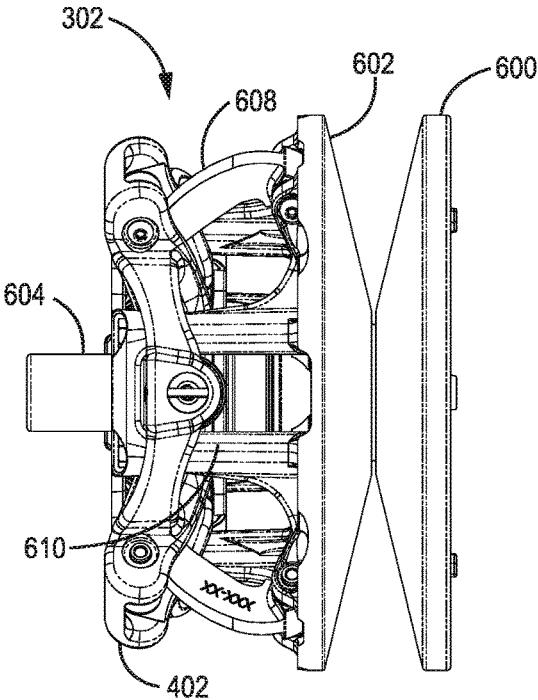


FIG. 6C

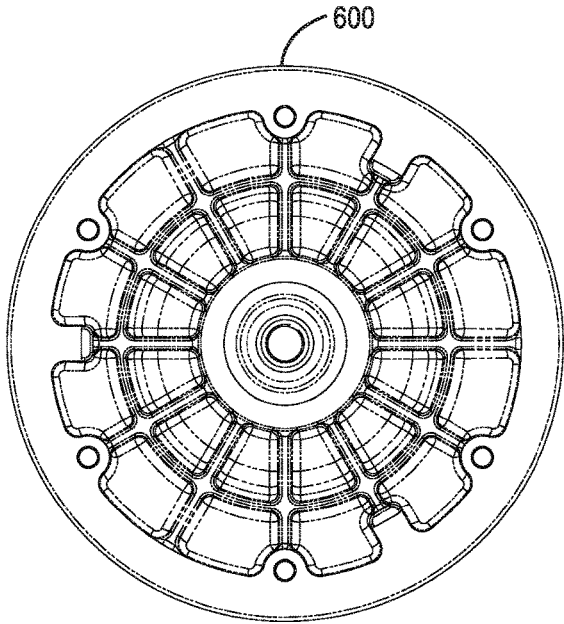


FIG. 6D

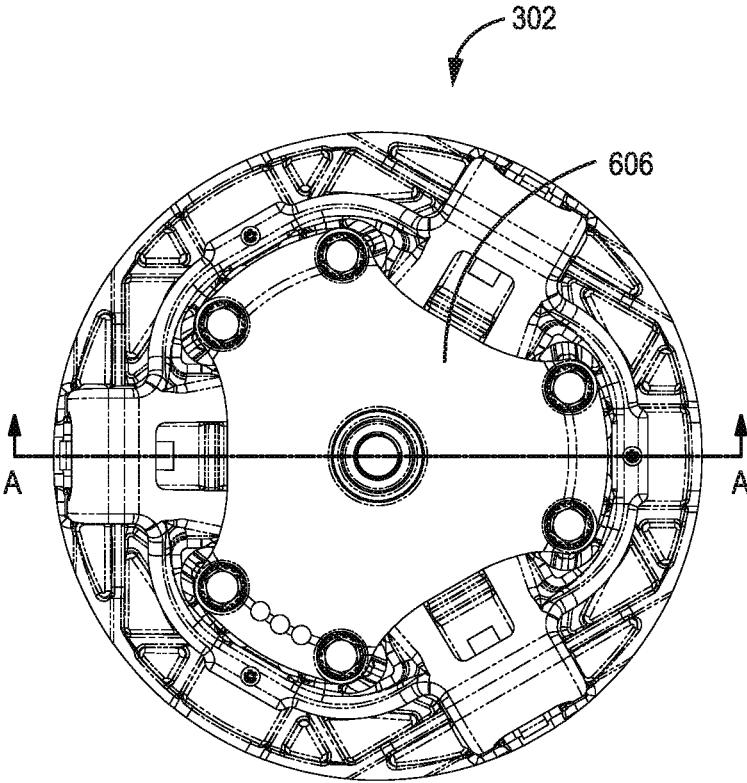
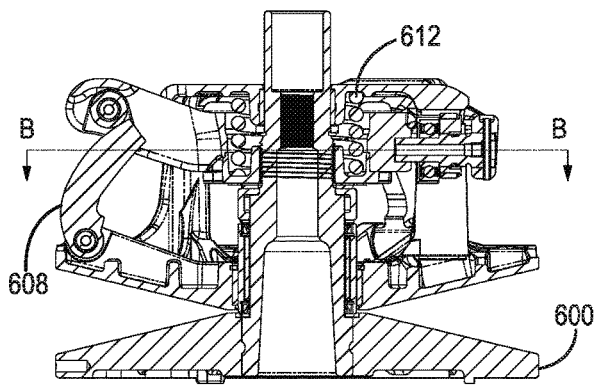
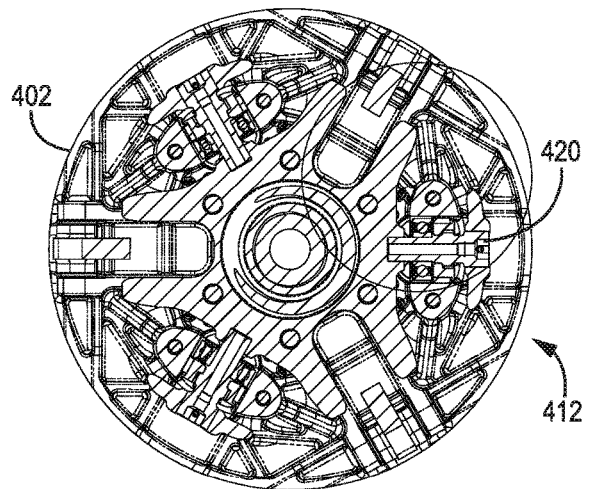


FIG. 6E



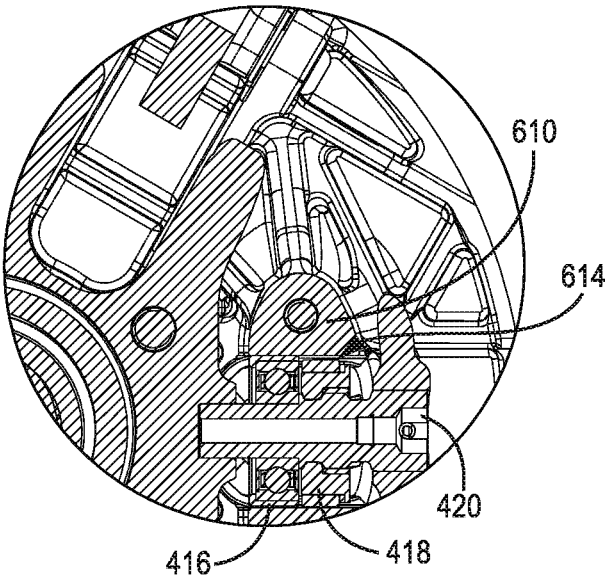
SECTION A-A

FIG. 6F



SECTION B-B

FIG. 6G



**FIG. 6H**

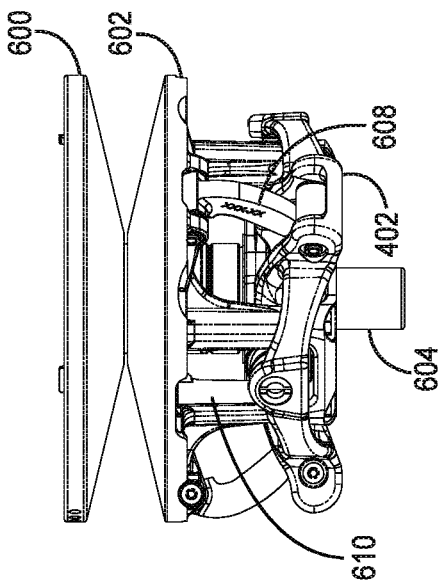


FIG. 7A

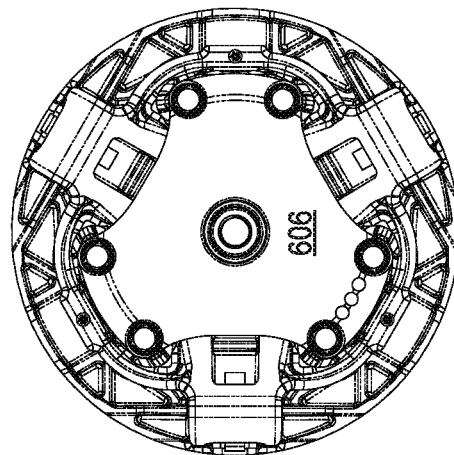


FIG. 7B

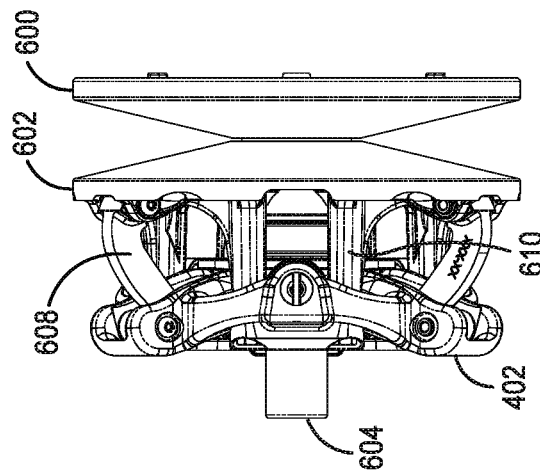


FIG. 7C

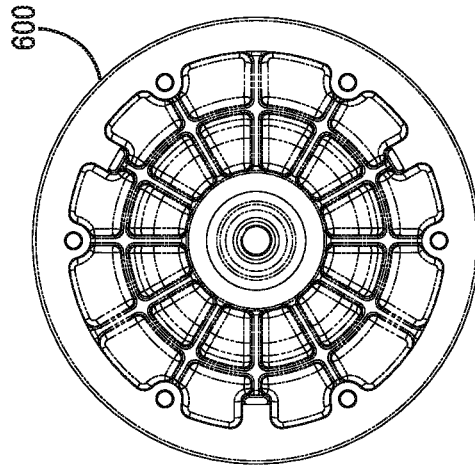


FIG. 7D

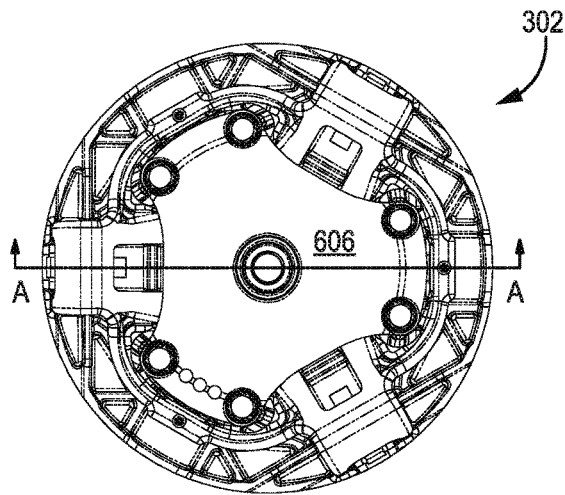
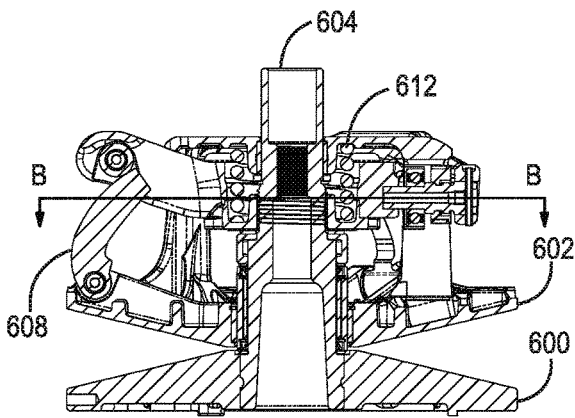
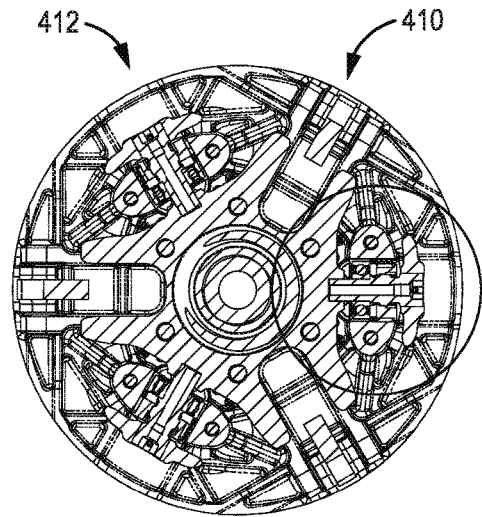


FIG. 7E



SECTION A-A

FIG. 7F



SECTION B-B

FIG. 7G

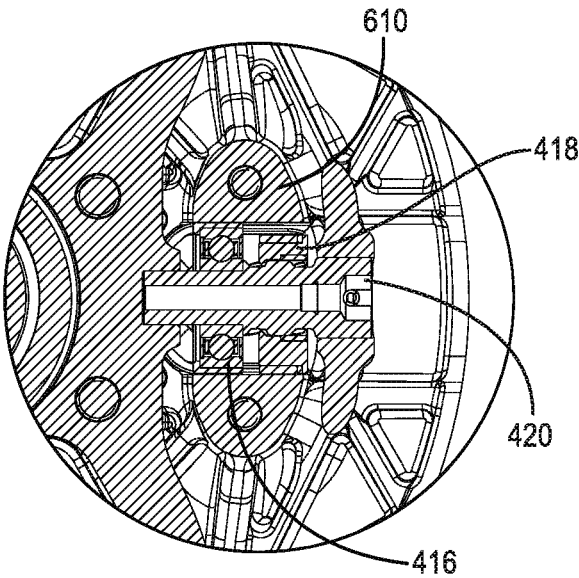


FIG. 7H

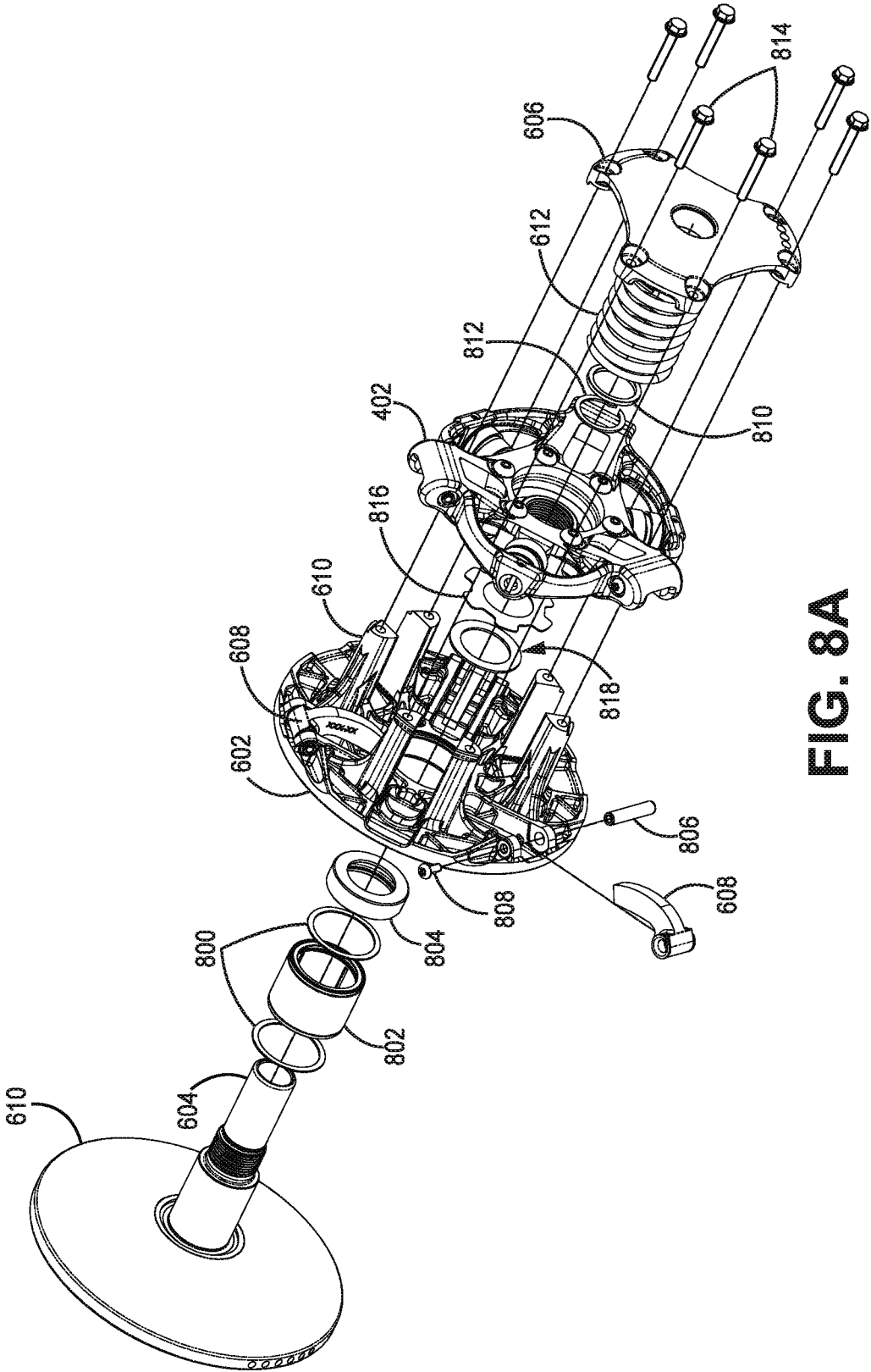


FIG. 8A

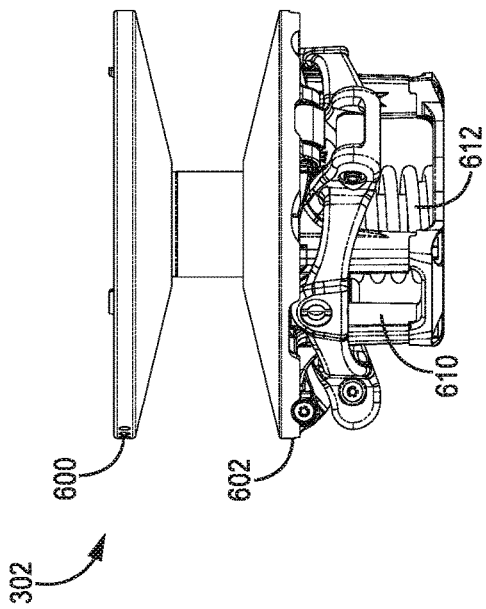


FIG. 8B

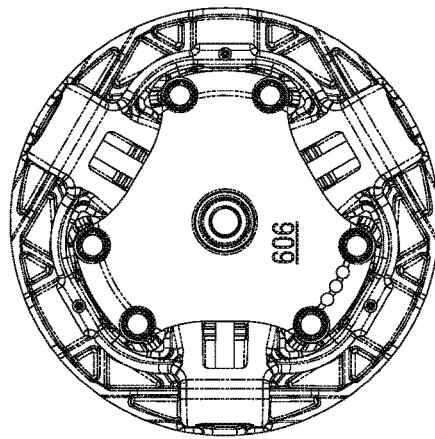


FIG. 8C

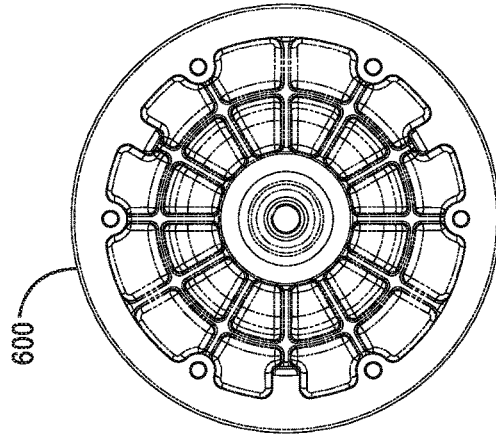


FIG. 8E

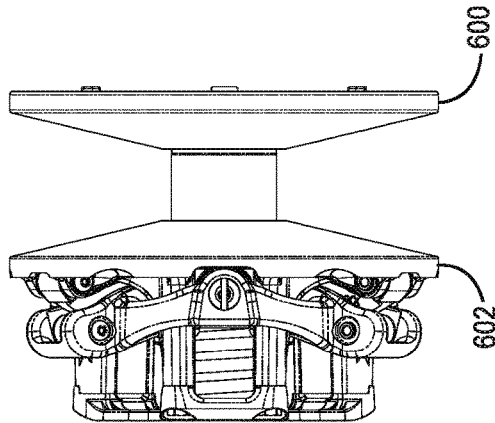
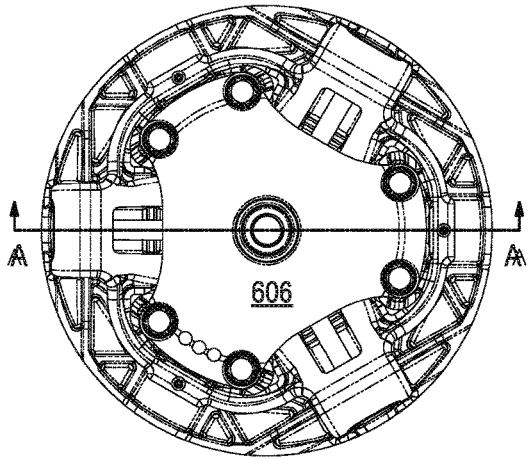
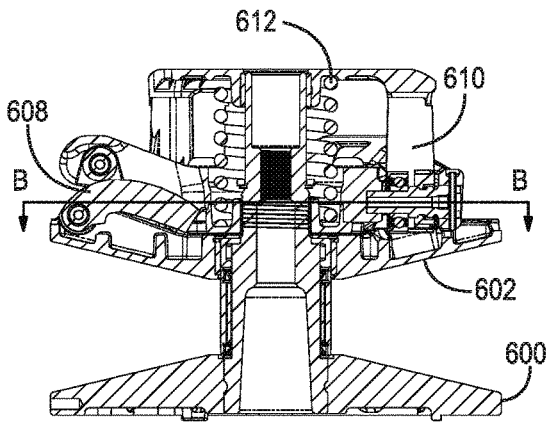


FIG. 8D

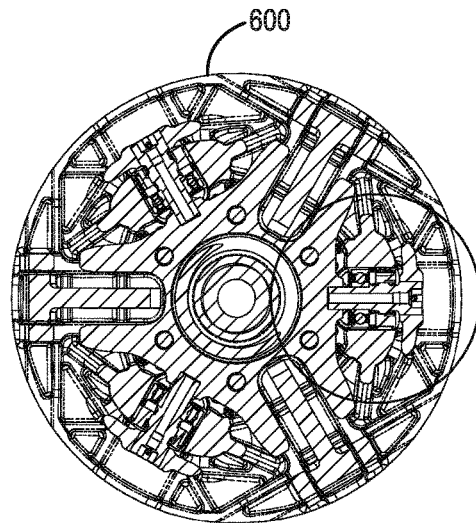


**FIG. 8F**



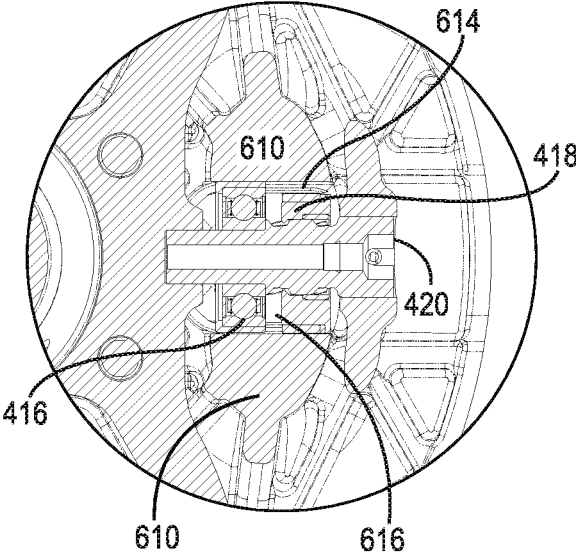
SECTION A-A

**FIG. 8G**



SECTION B-B

**FIG. 8H**



**FIG. 8I**

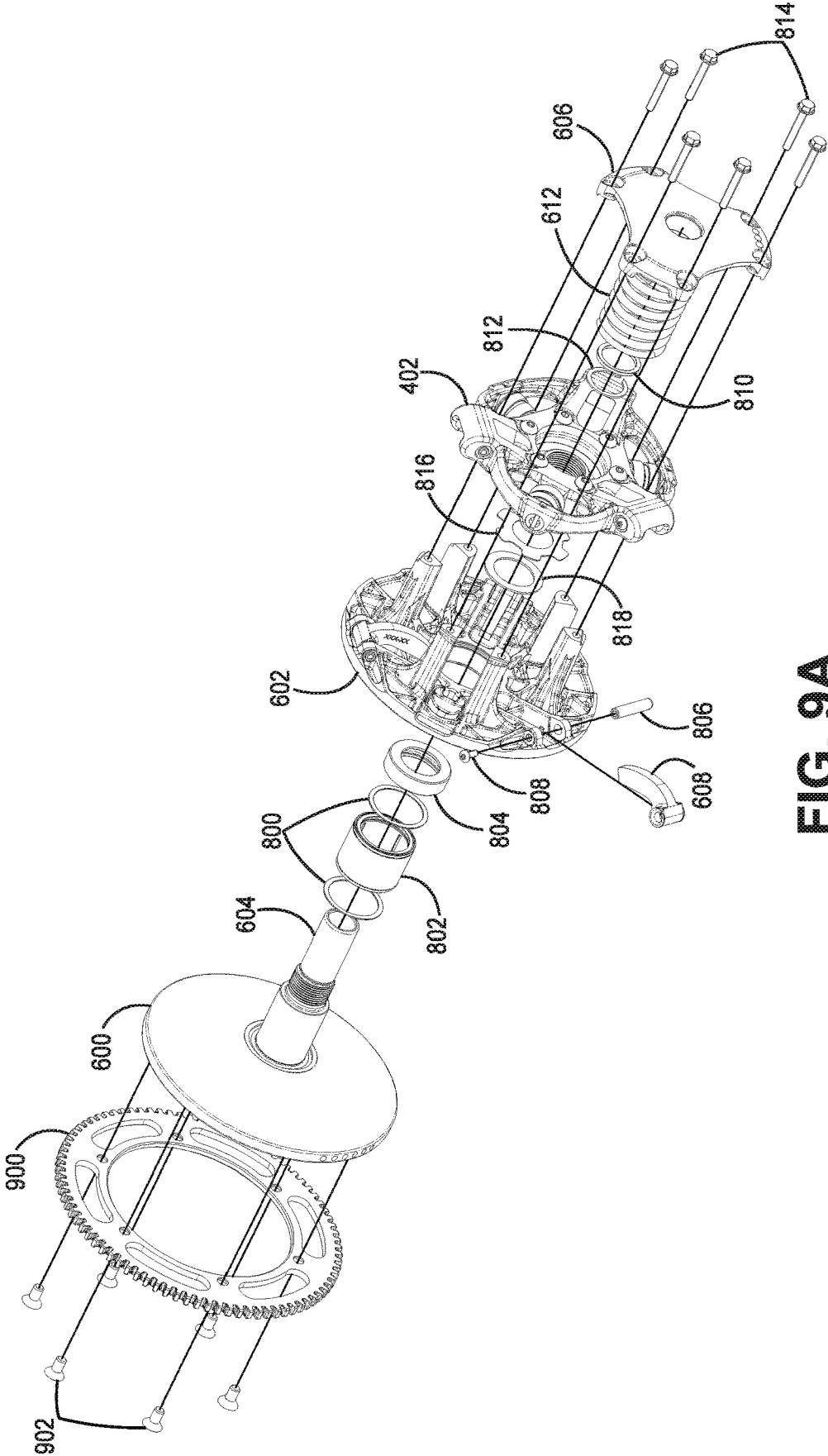


FIG. 9A

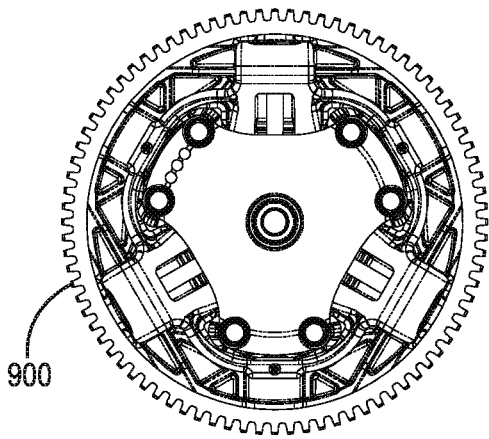


FIG. 9B

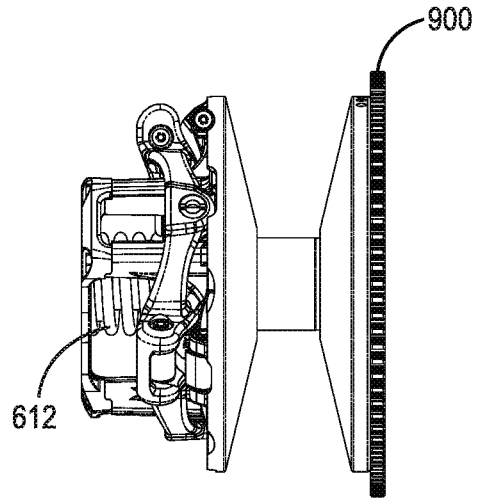


FIG. 9E

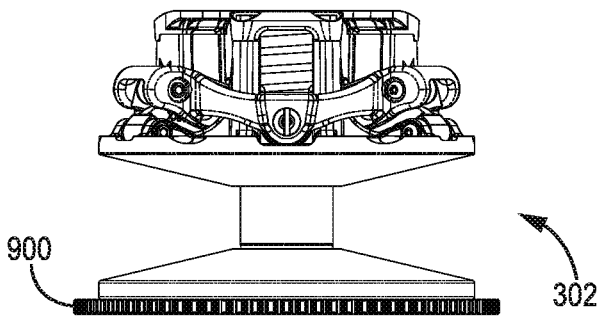


FIG. 9C

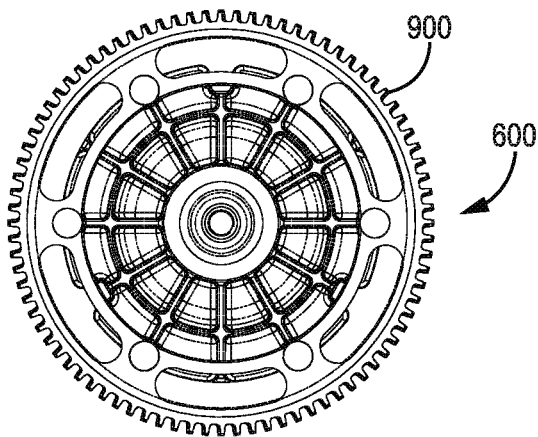


FIG. 9D

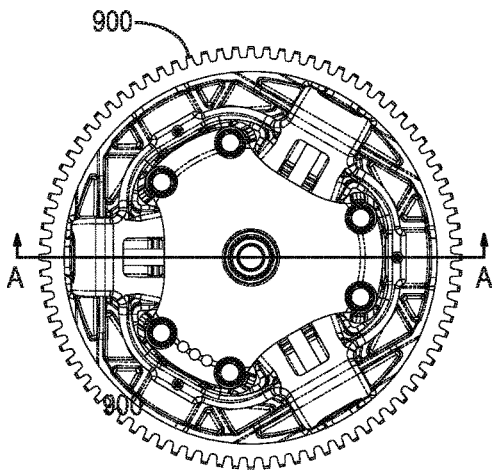


FIG. 9F

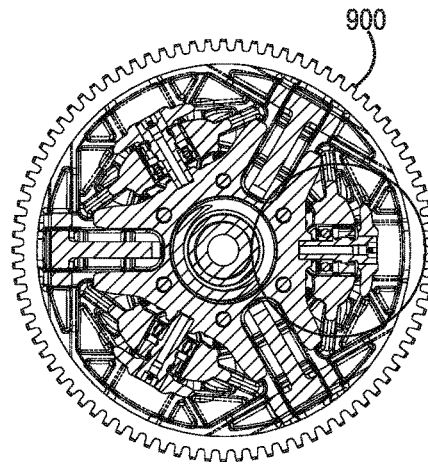


FIG. 9H

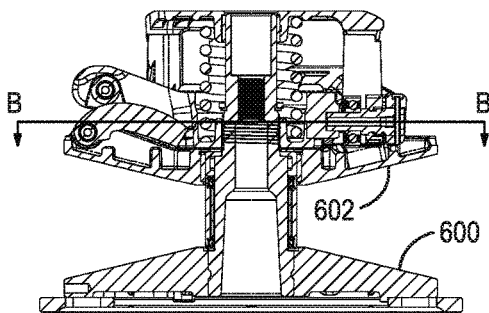


FIG. 9G

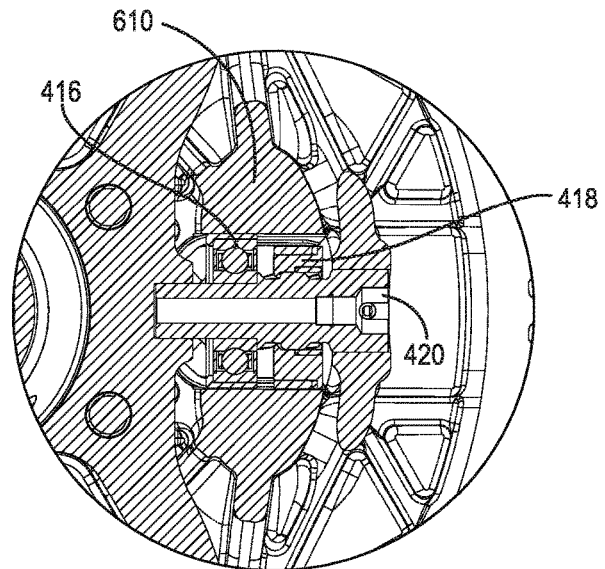


FIG. 9I

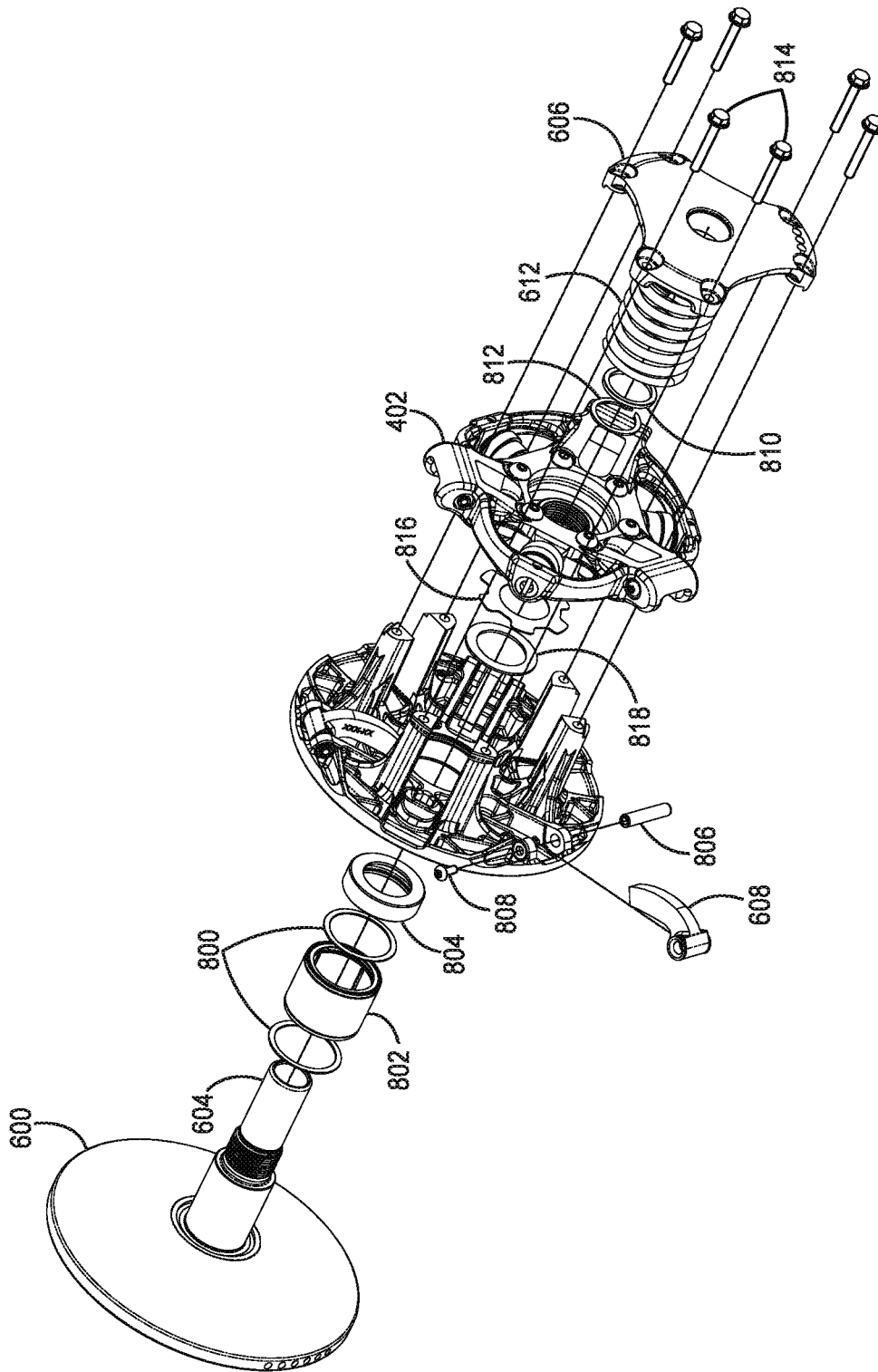


FIG. 10A

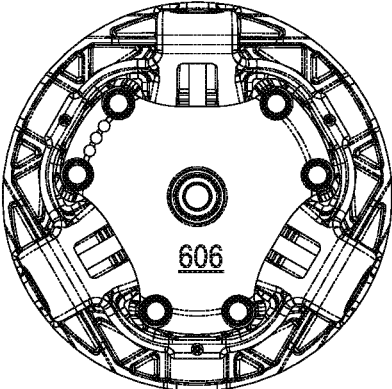


FIG. 10B

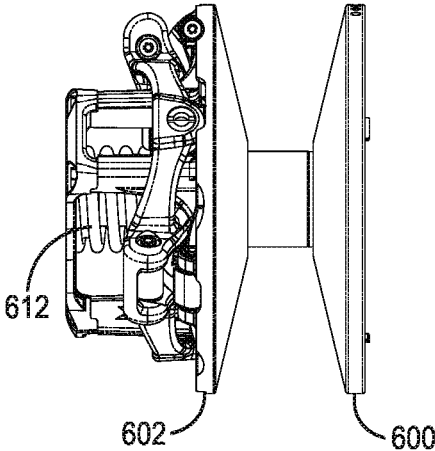


FIG. 10E

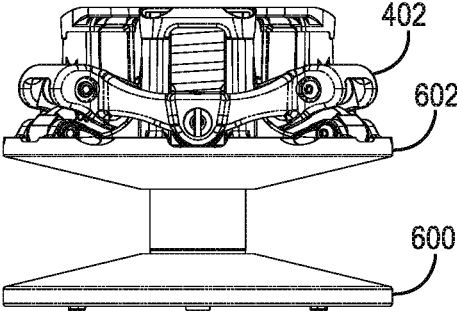


FIG. 10C

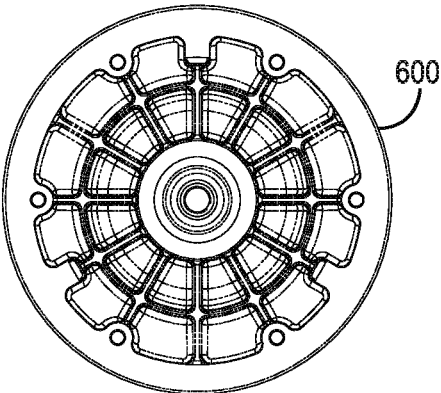


FIG. 10D

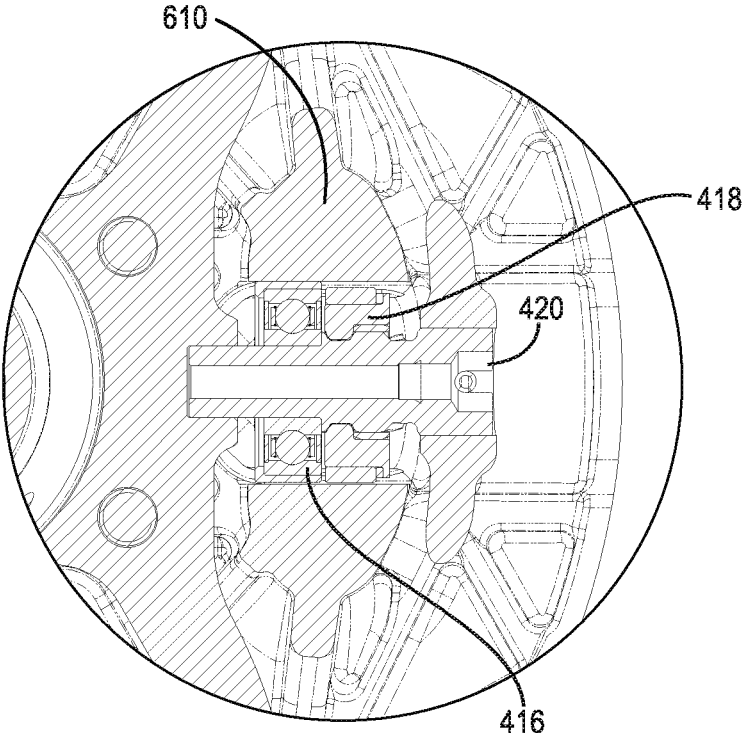


FIG. 10F

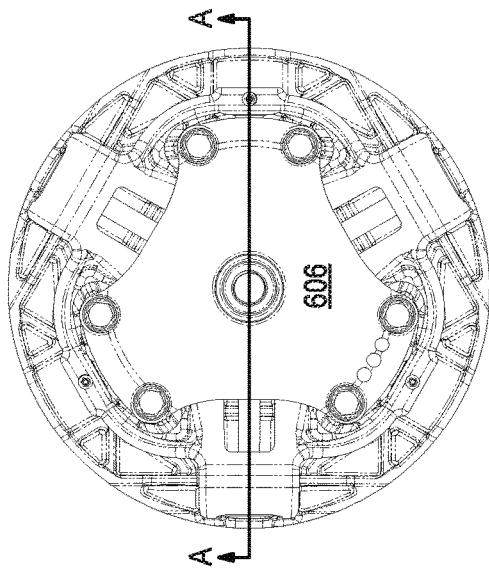
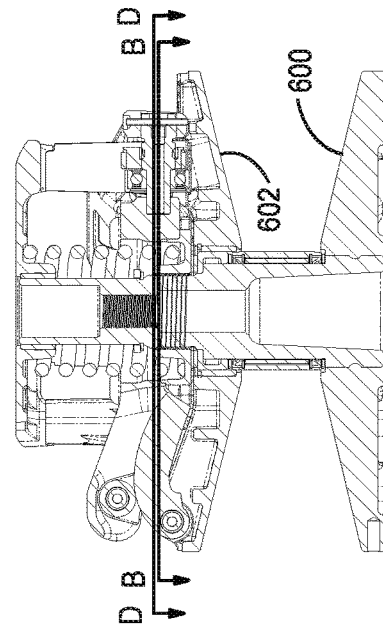
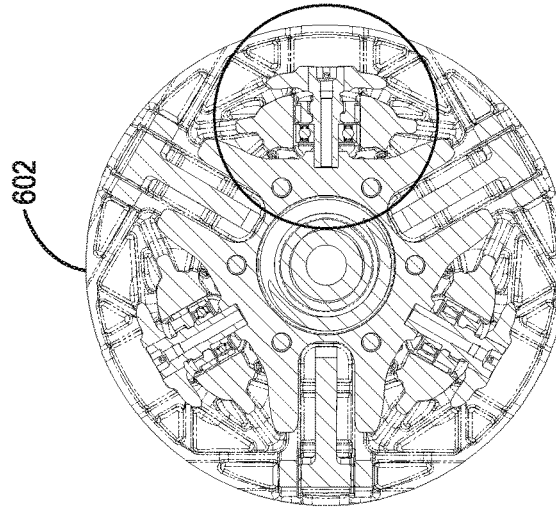


FIG. 10G



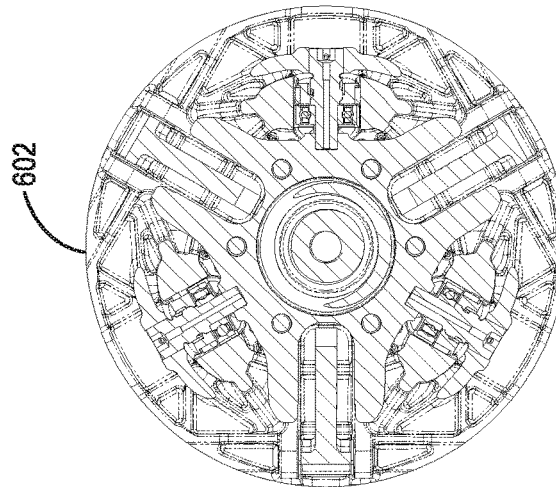
SECTION A-A

FIG. 10H



SECTION B-B

FIG. 10I



SECTION D-D

FIG. 10J

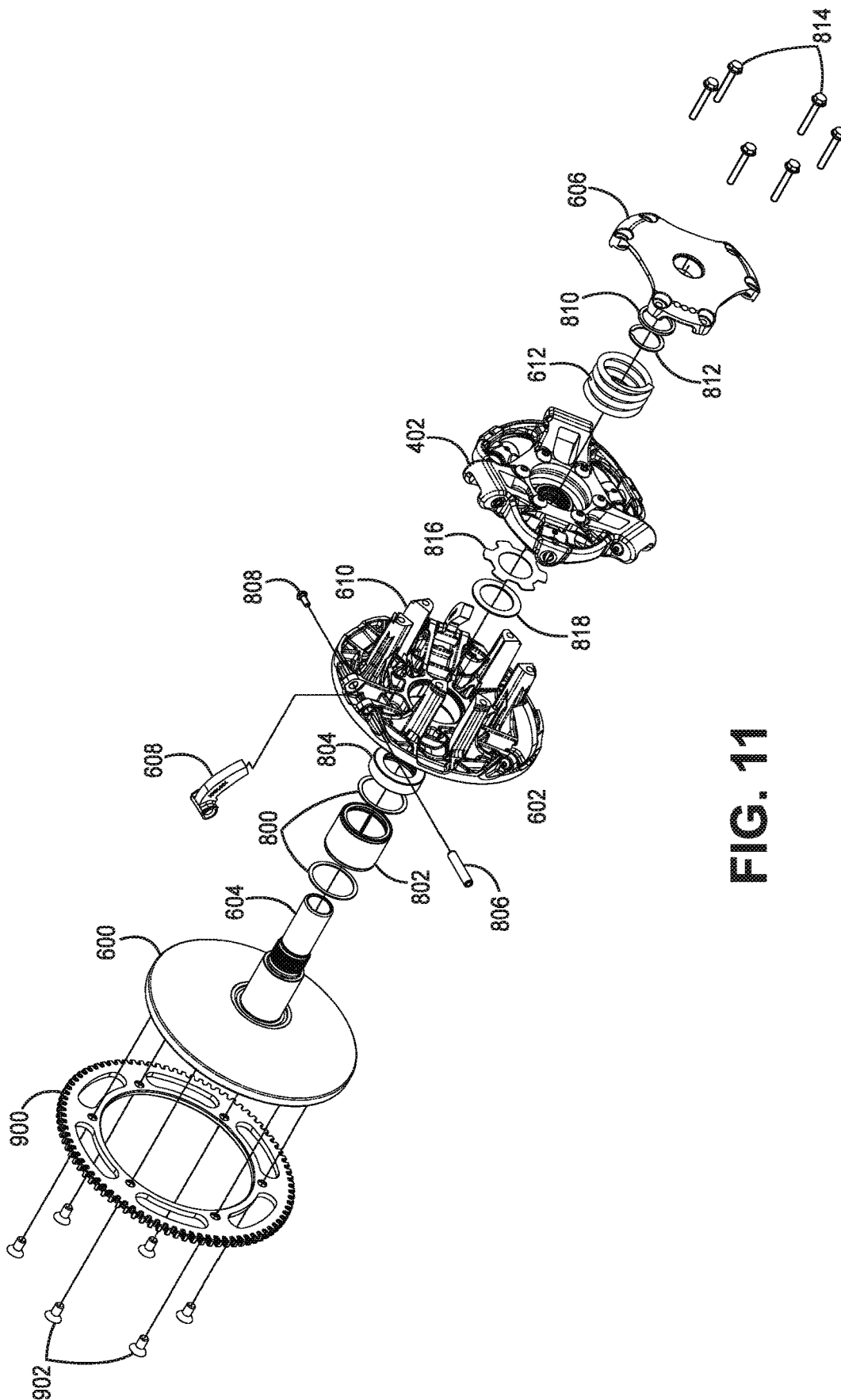


FIG. 11

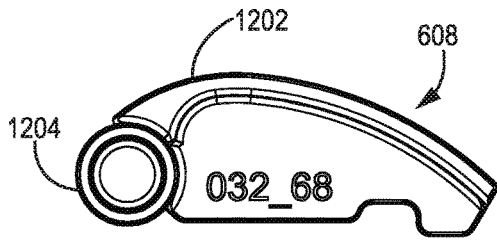


FIG. 12A

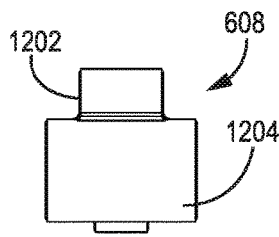


FIG. 12C

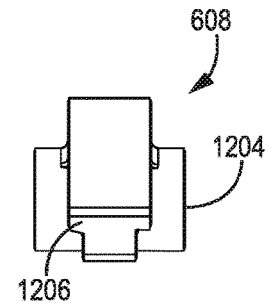


FIG. 12E

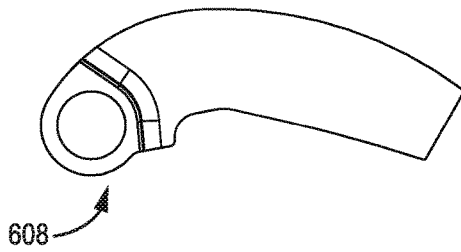


FIG. 12B

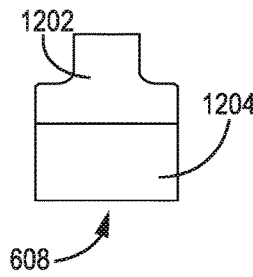


FIG. 12D

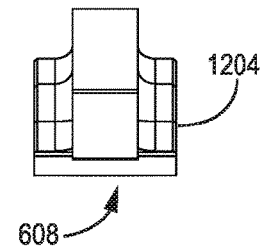
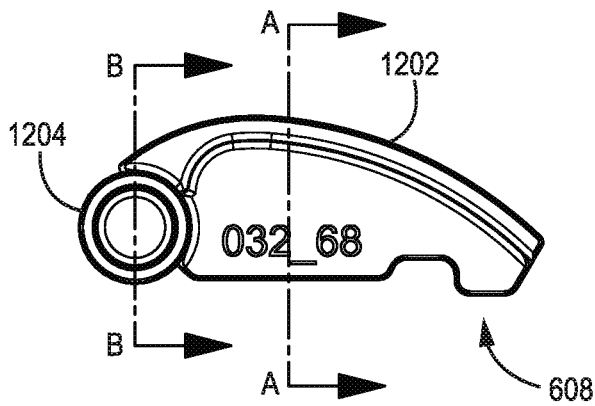
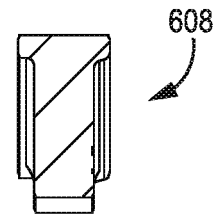


FIG. 12F

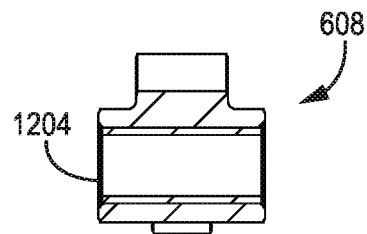


**FIG. 12G**



SECTION A-A

**FIG. 12H**



SECTION B-B

**FIG. 12I**

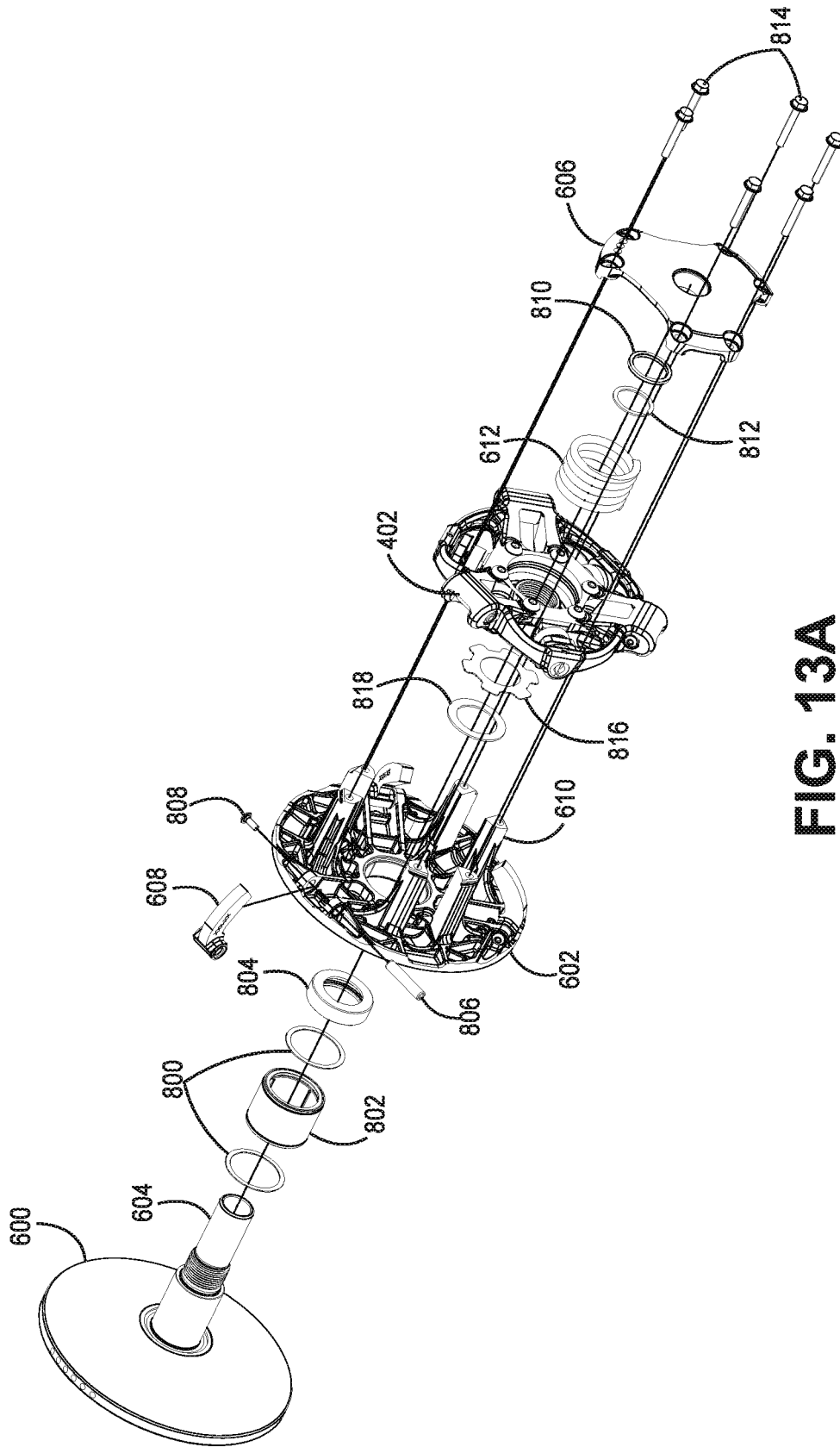
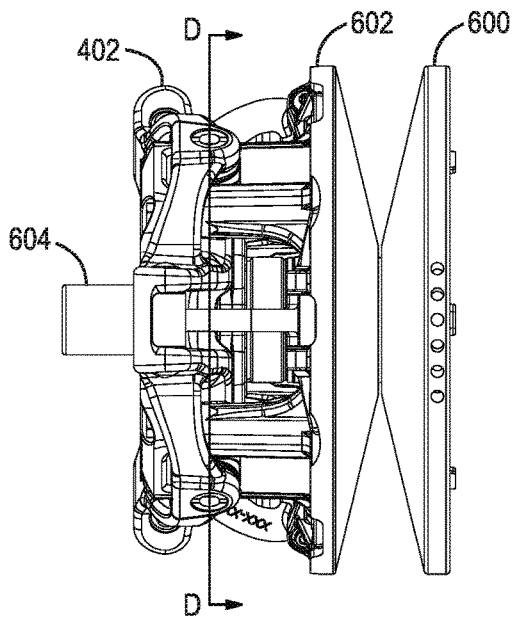
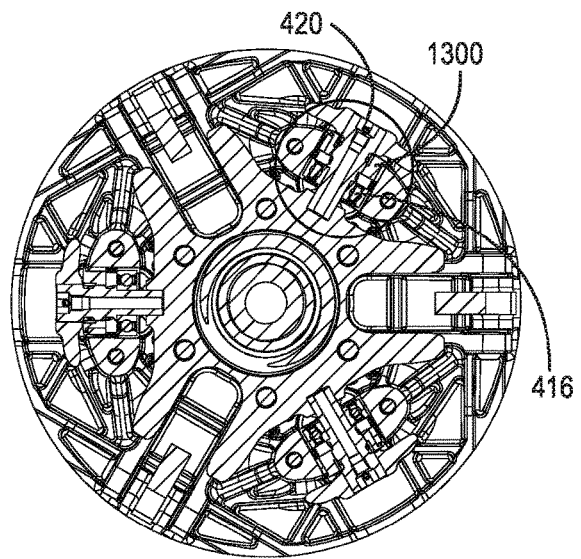


FIG. 13A

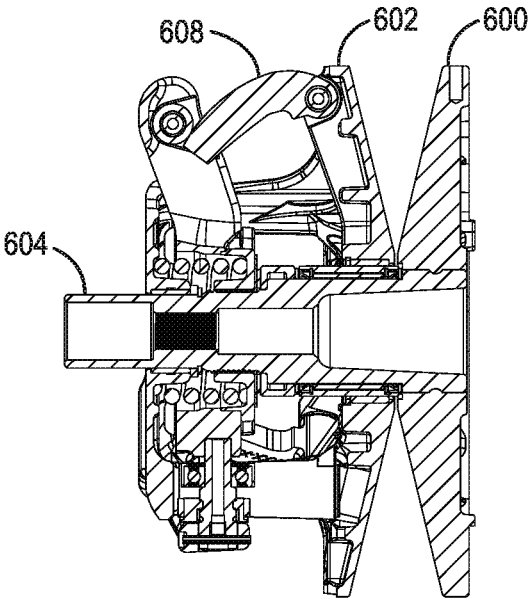


**FIG. 13B**



SECTION D-D

**FIG. 13C**



SECTION F-F

FIG. 13D

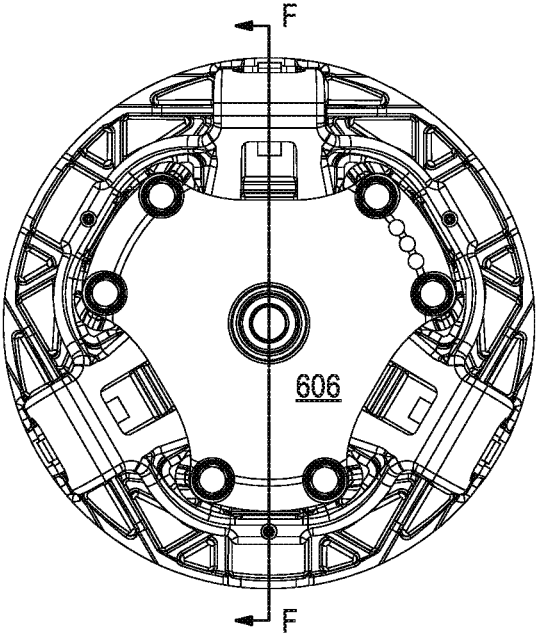
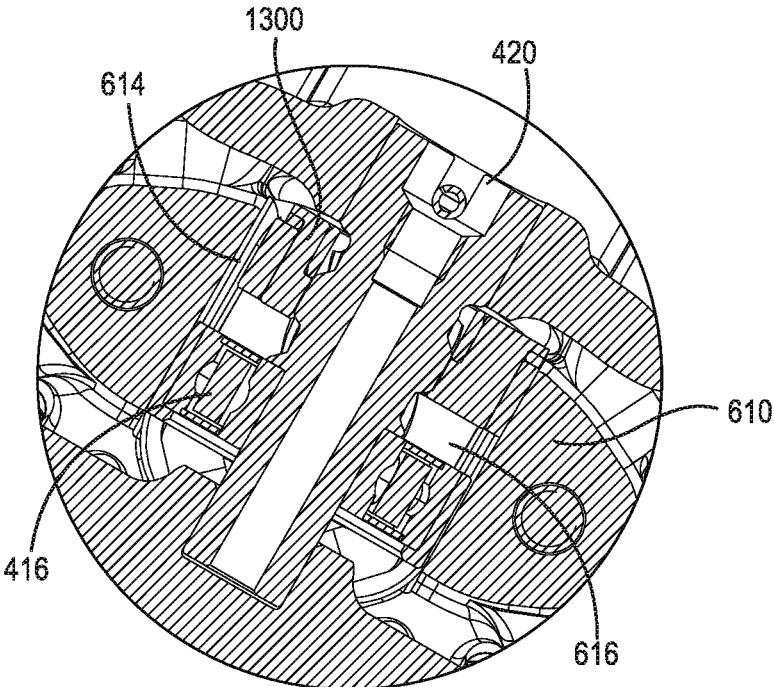


FIG. 13E



**FIG. 13F**

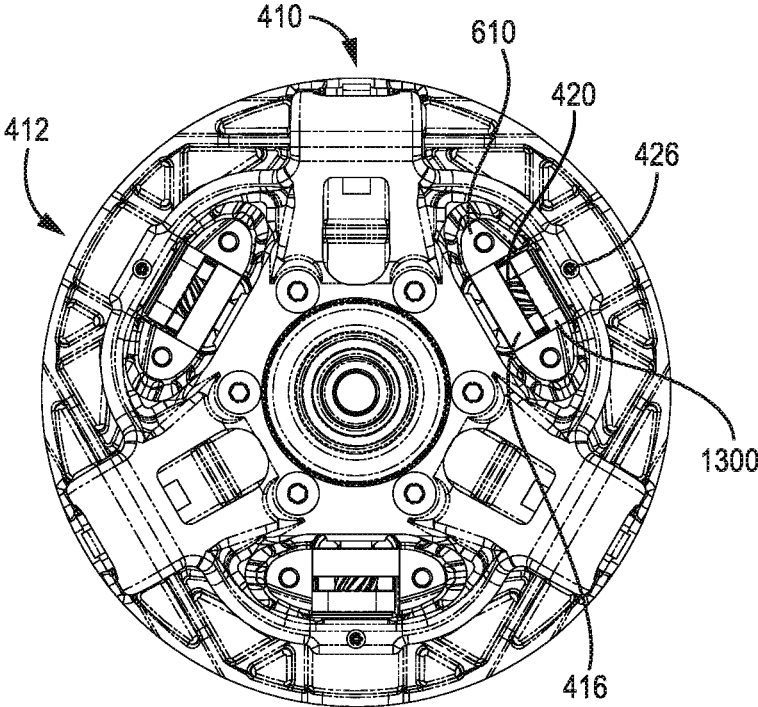


FIG. 13G

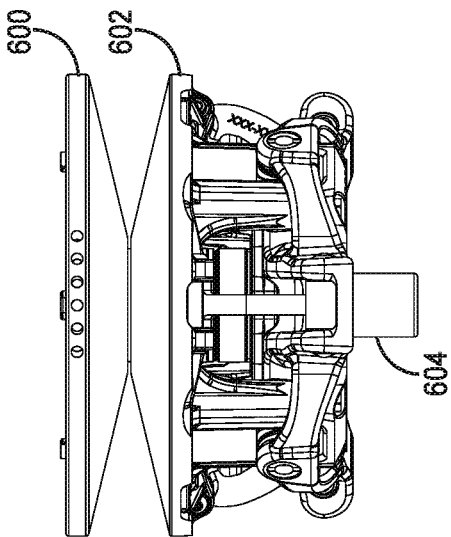


FIG. 13H

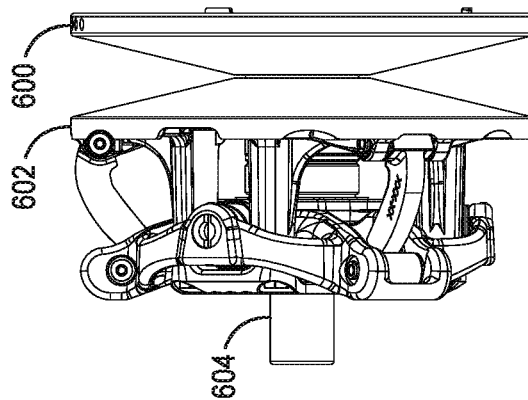


FIG. 13J

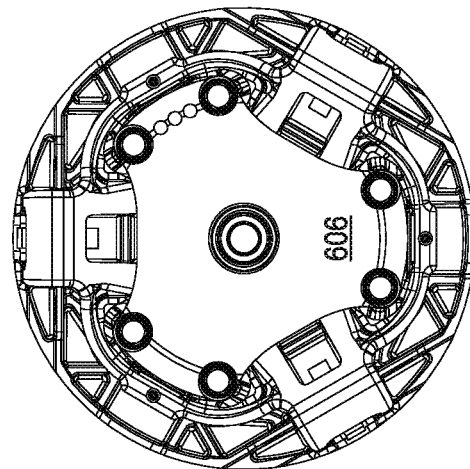


FIG. 13I

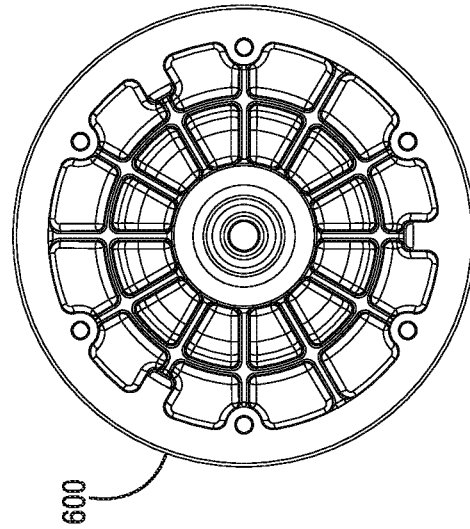


FIG. 13K

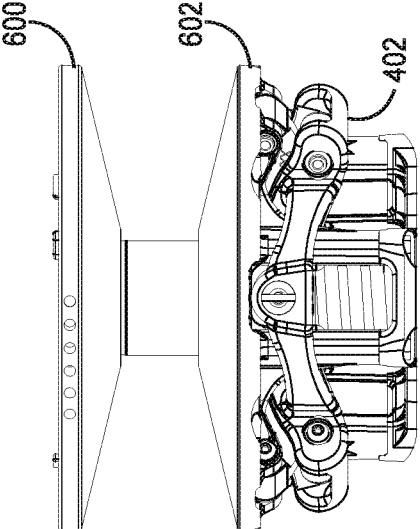


FIG. 14A

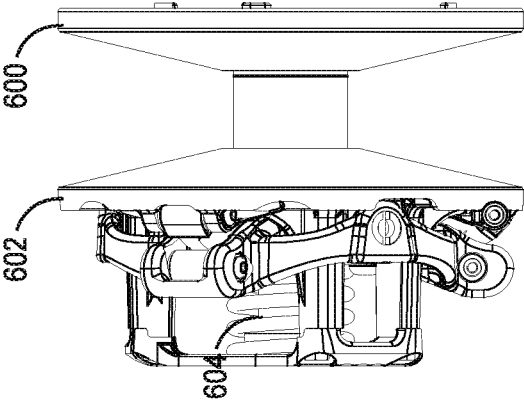


FIG. 14C

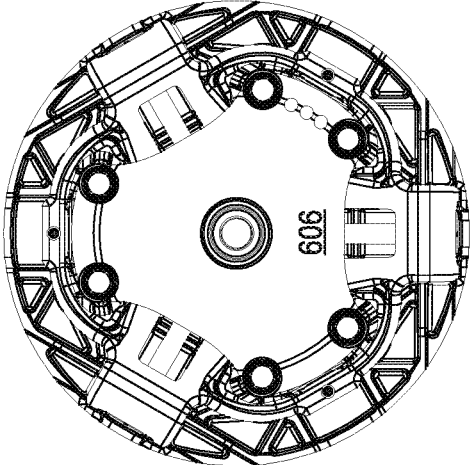


FIG. 14B

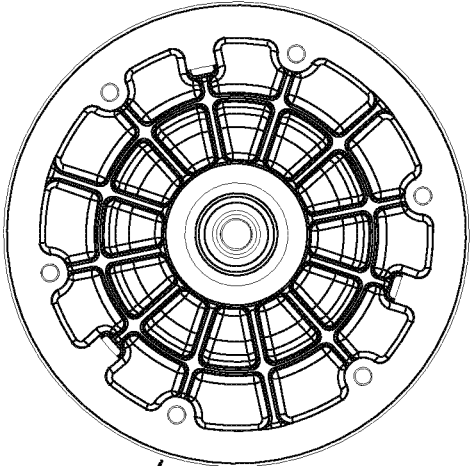


FIG. 14D

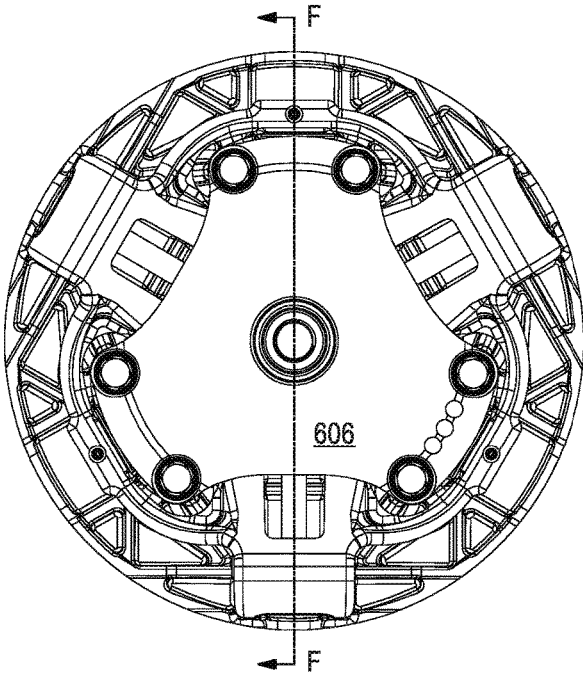
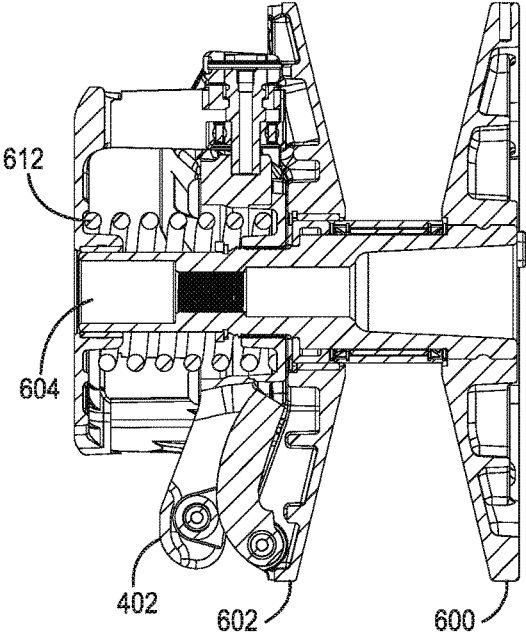
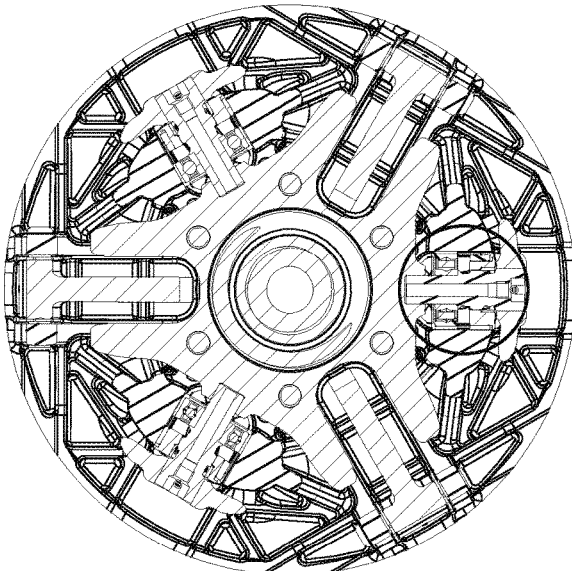


FIG. 14E



SECTION F-F

FIG. 14F



SECTION D-D

FIG. 14G

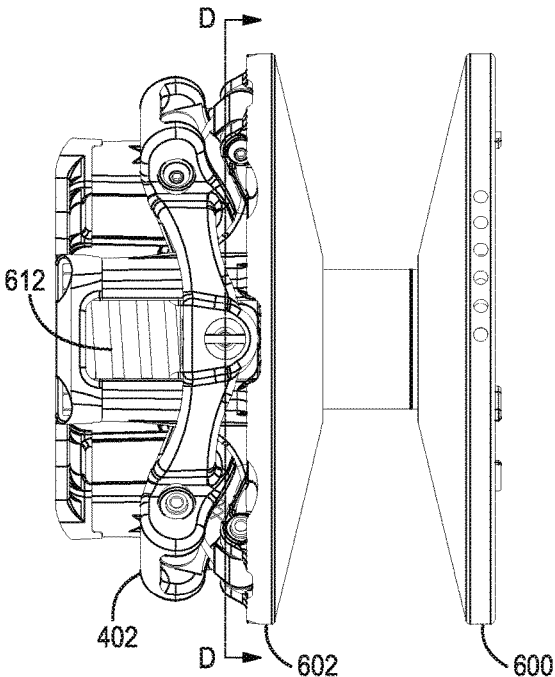


FIG. 14H

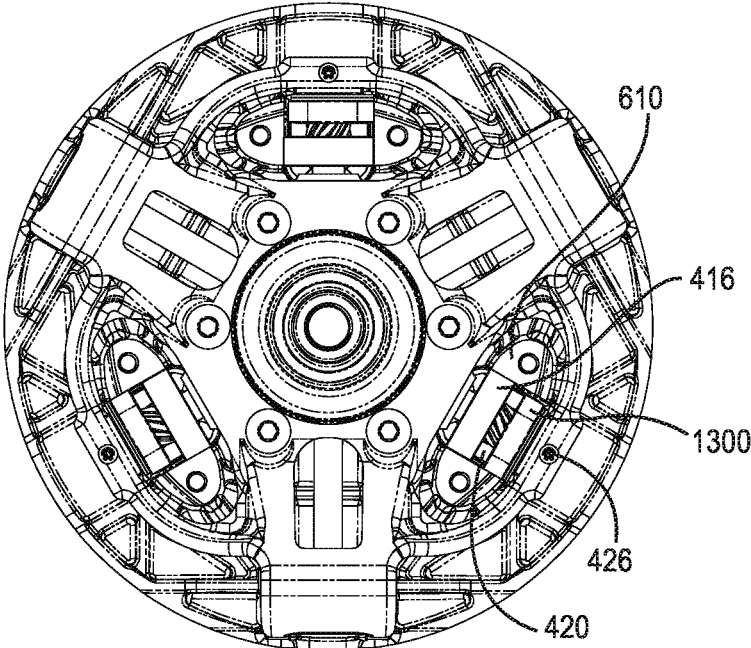


FIG. 14I

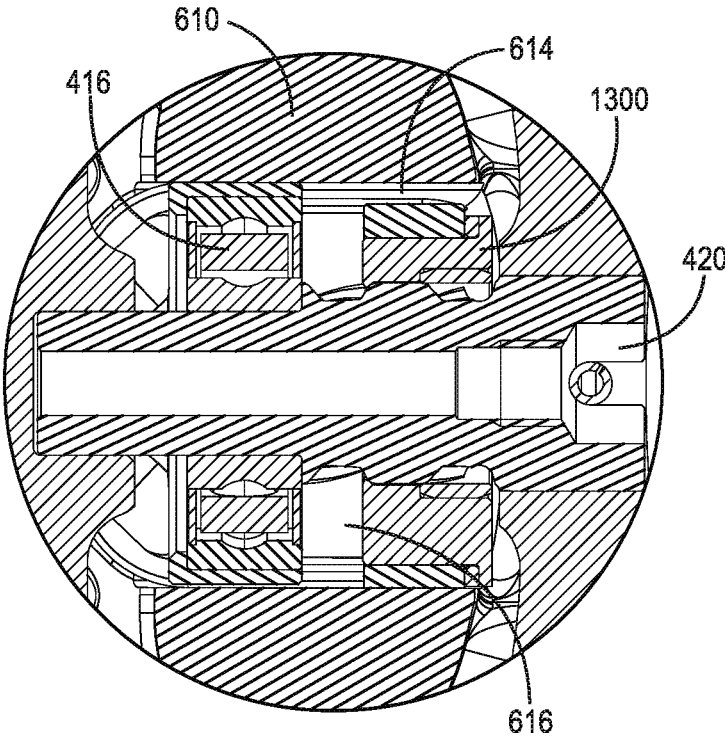


FIG. 14J

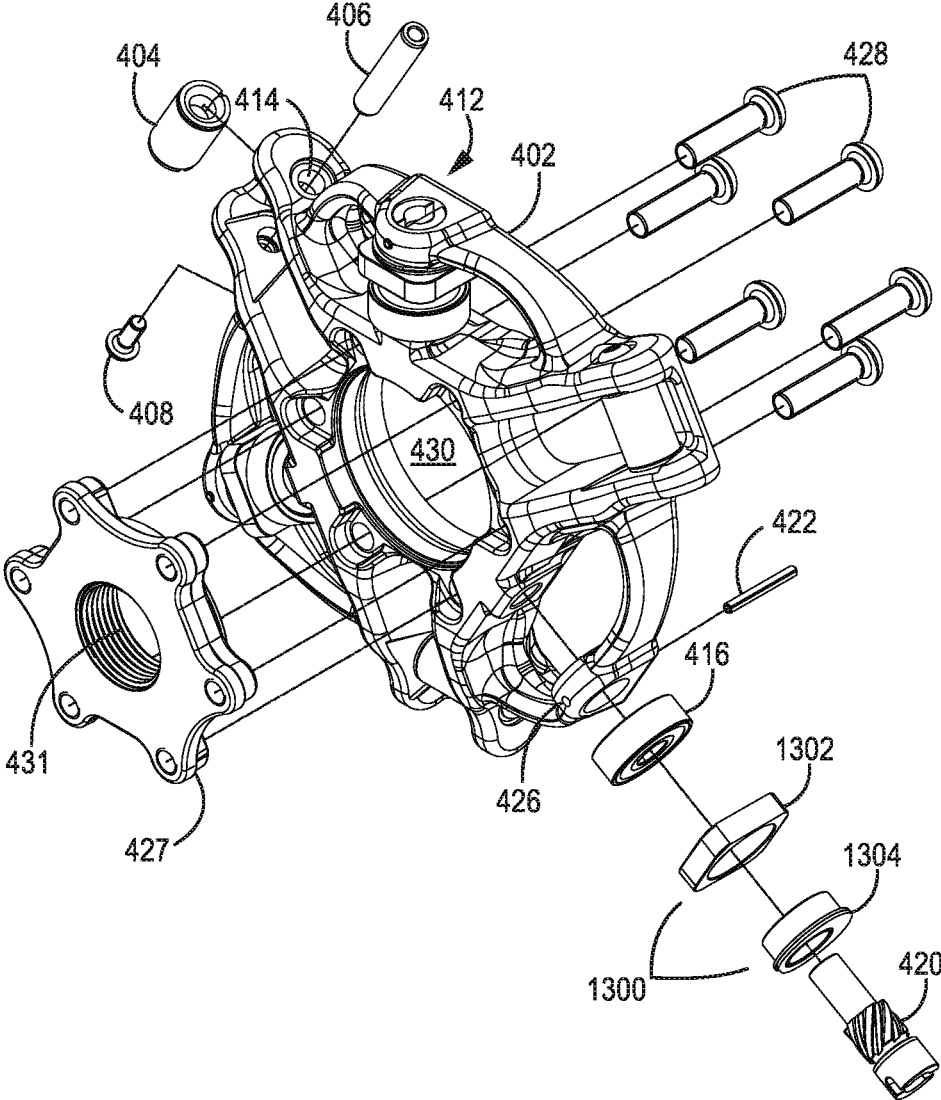


FIG. 15A

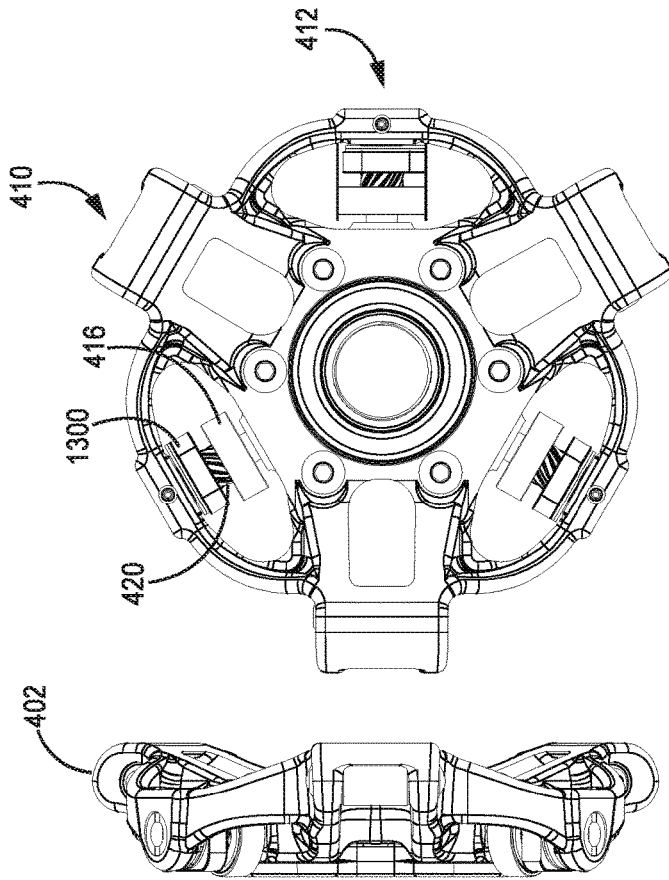


FIG. 15C

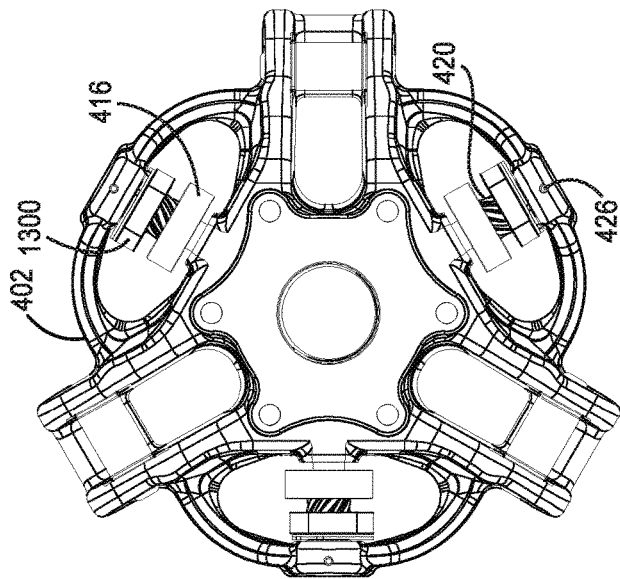


FIG. 15B

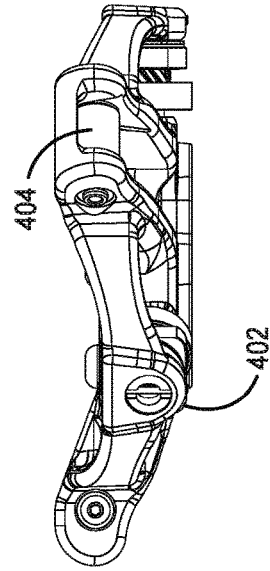
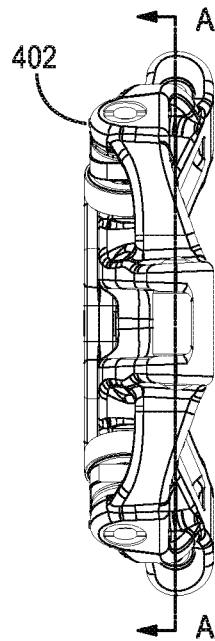
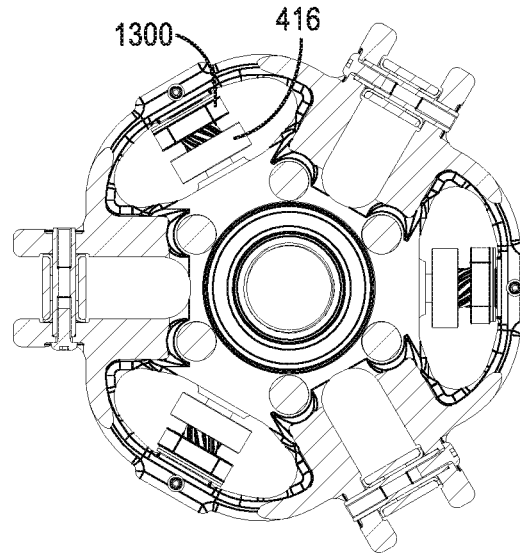


FIG. 15E

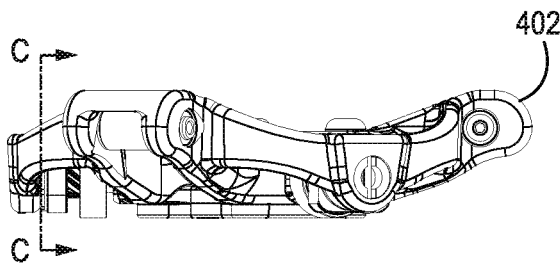


**FIG. 15F**

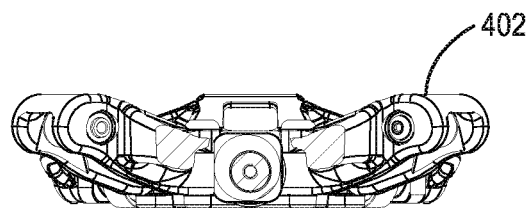


SECTION A-A

**FIG. 15G**



**FIG. 15H**



SECTION C-C

**FIG. 15I**

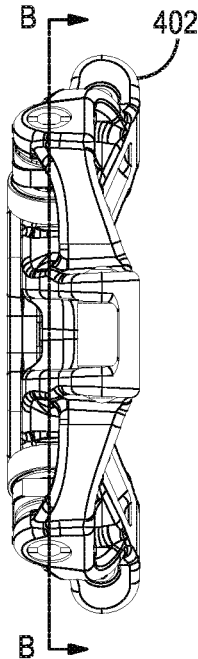


FIG. 15J

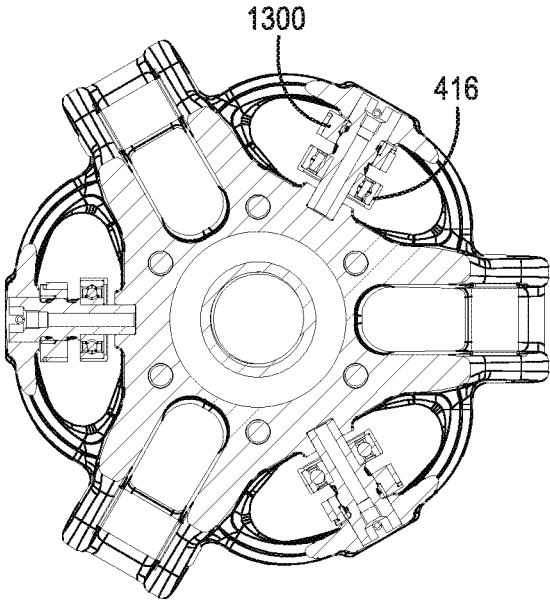


FIG. 15K

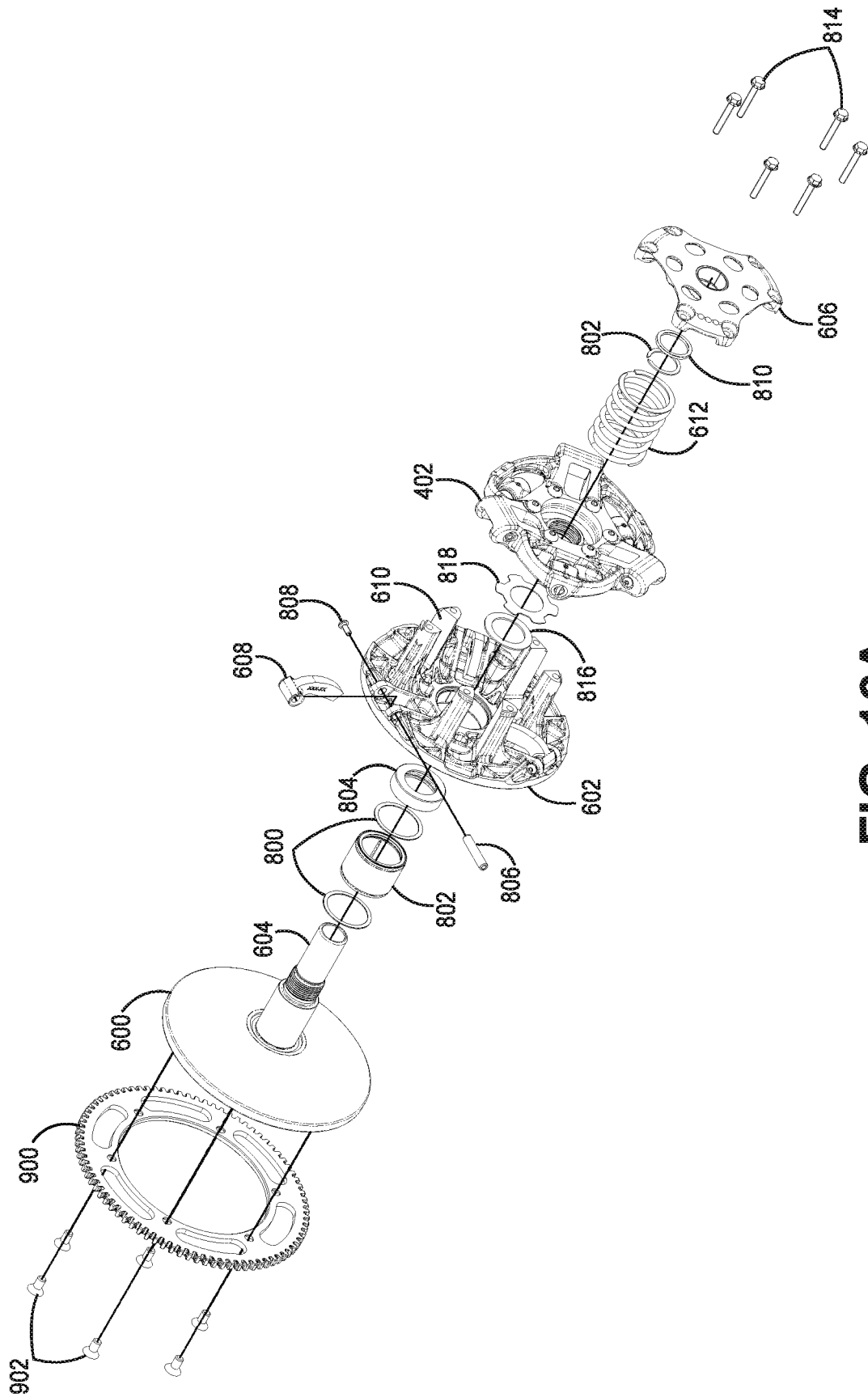


FIG. 16A

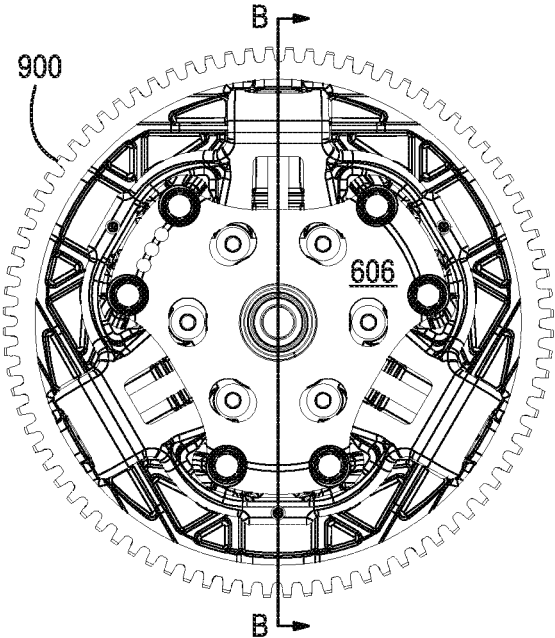
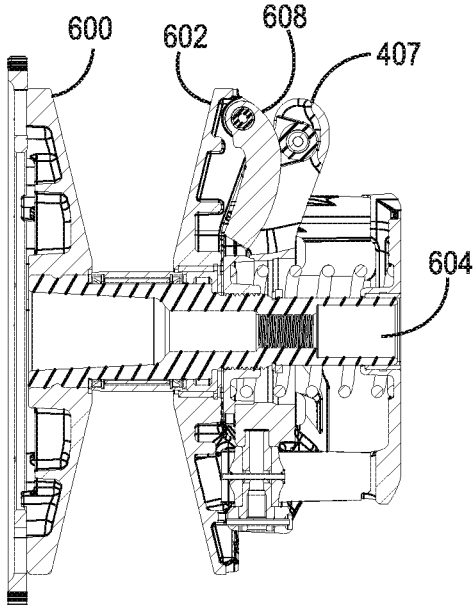


FIG. 16B



SECTION B-B  
FIG. 16C

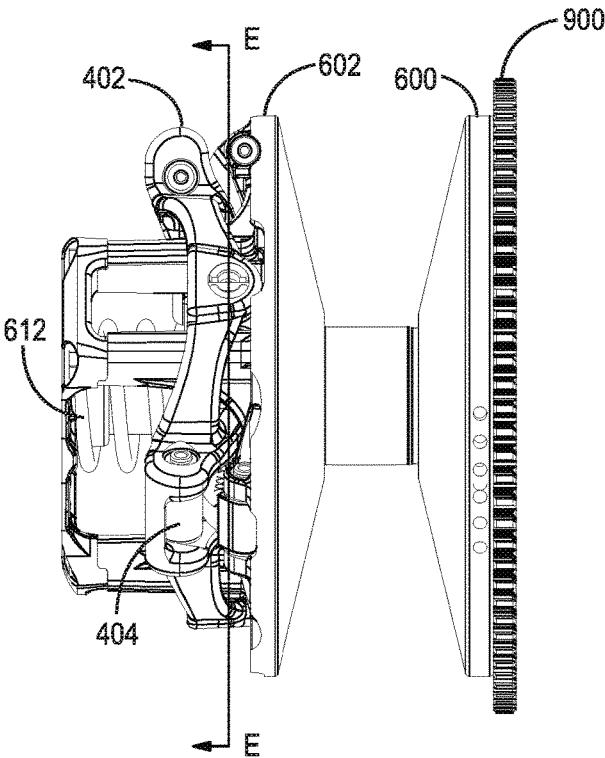
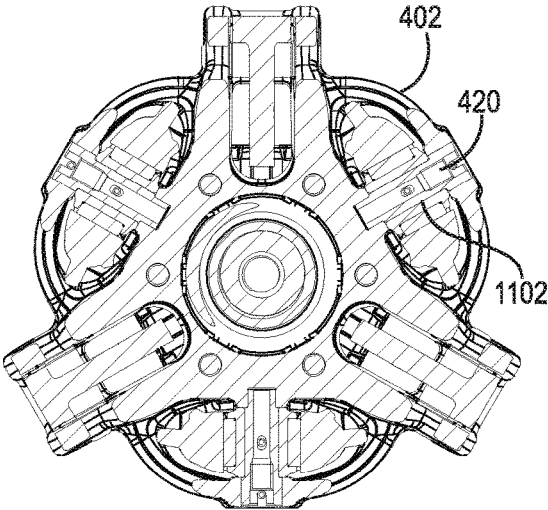
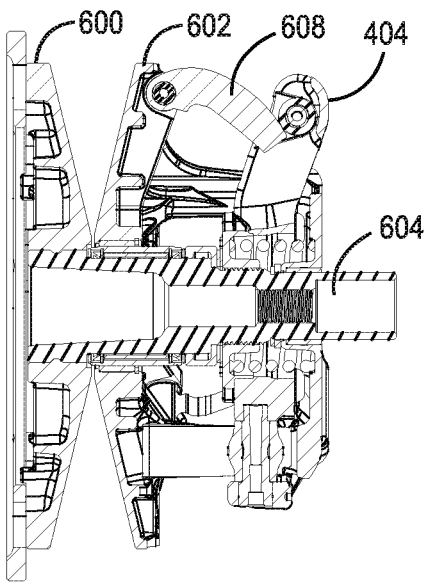


FIG. 16D



SECTION E-E

FIG. 16E



SECTION B-B

FIG. 16F

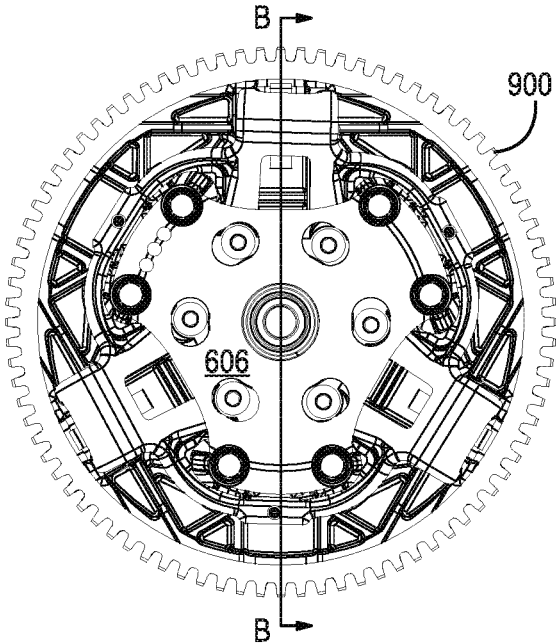
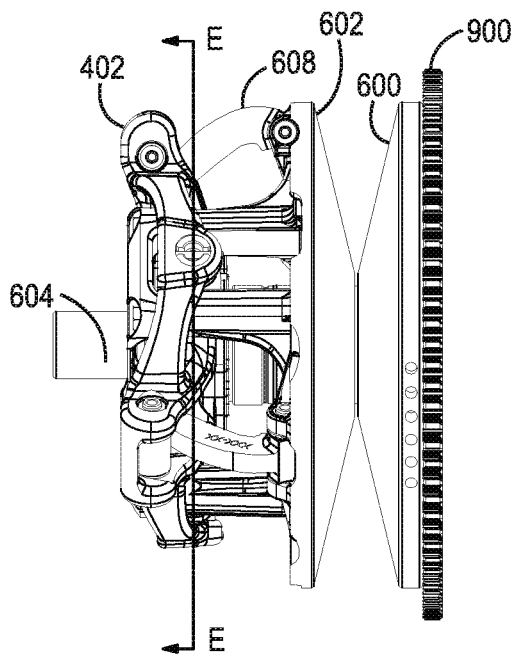
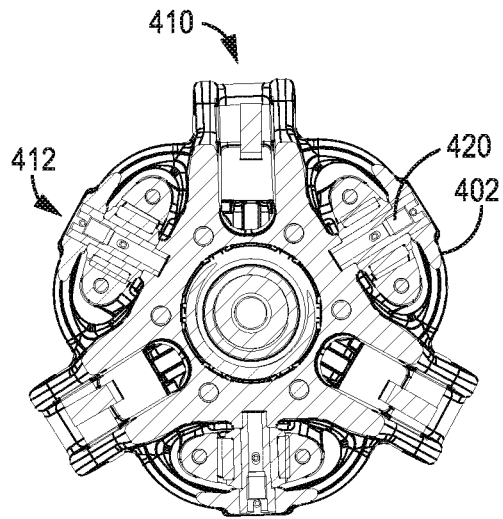


FIG. 16G



**FIG. 16H**



SECTION E-E

**FIG. 16I**

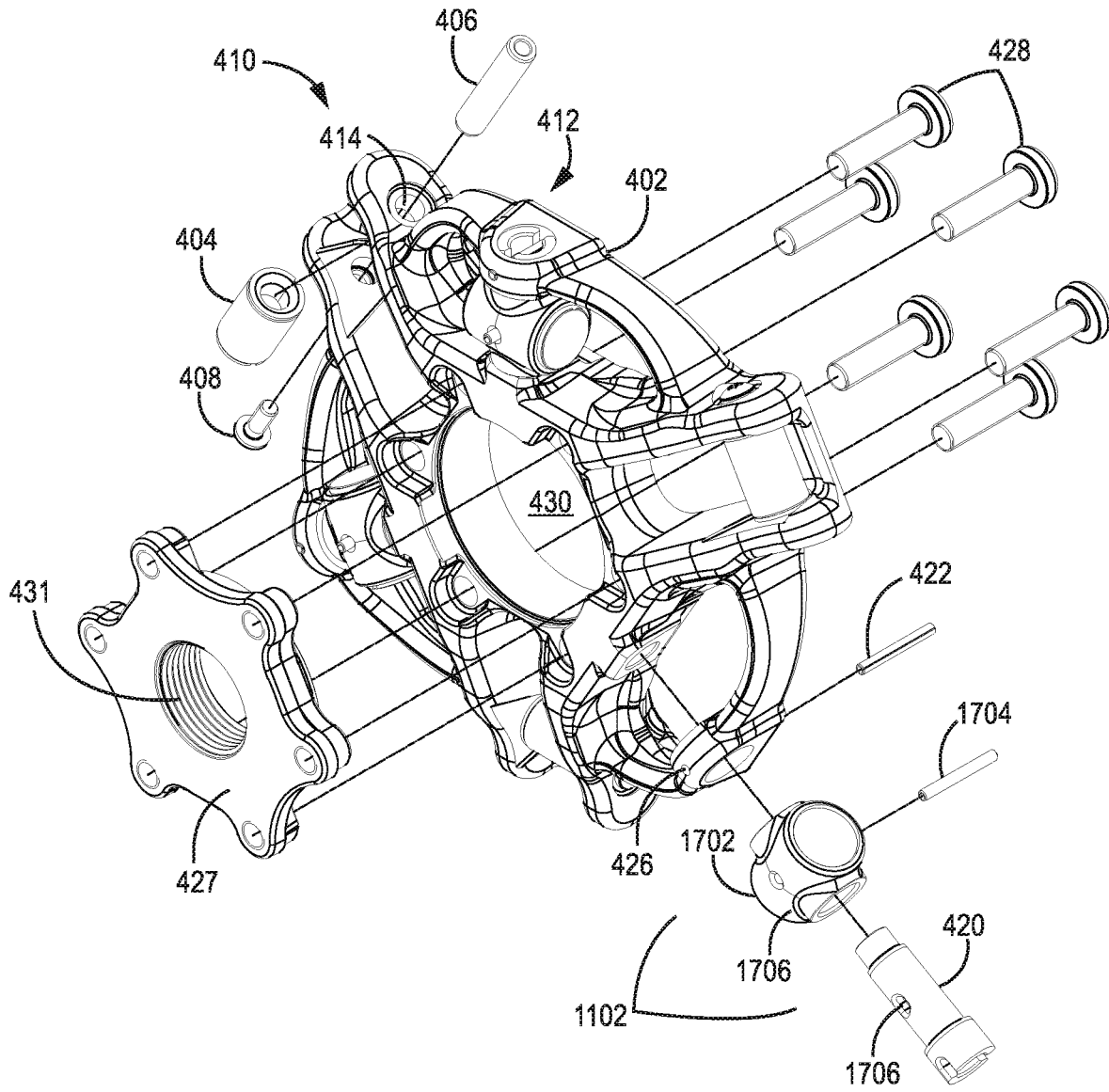
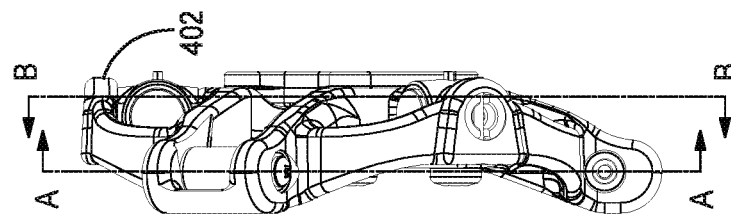
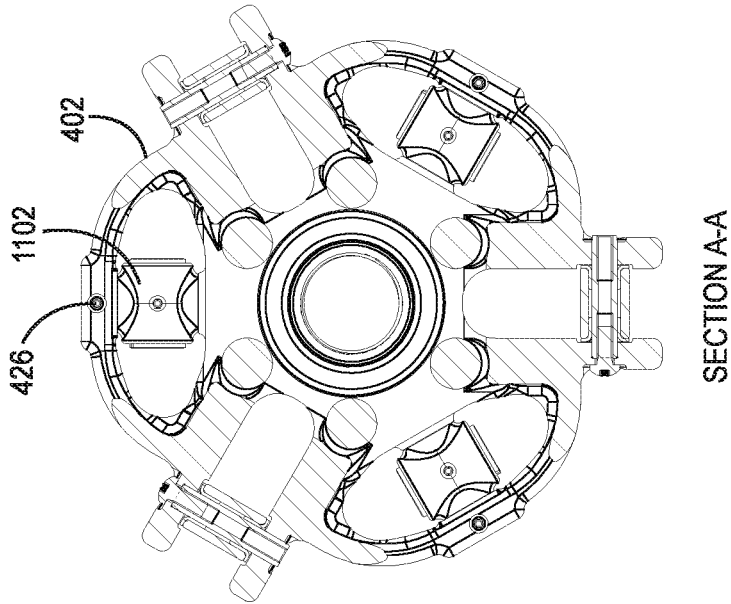
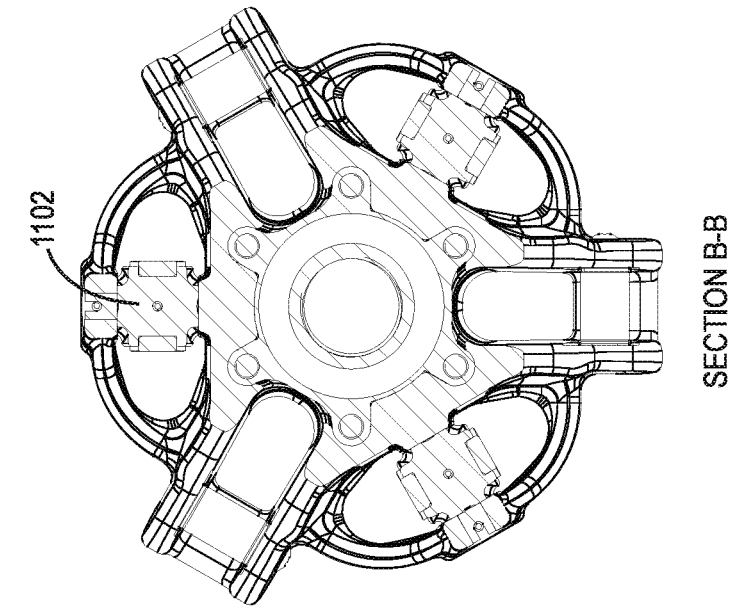


FIG. 17A



**FIG. 17B**

**FIG. 17C**

**FIG. 17D**

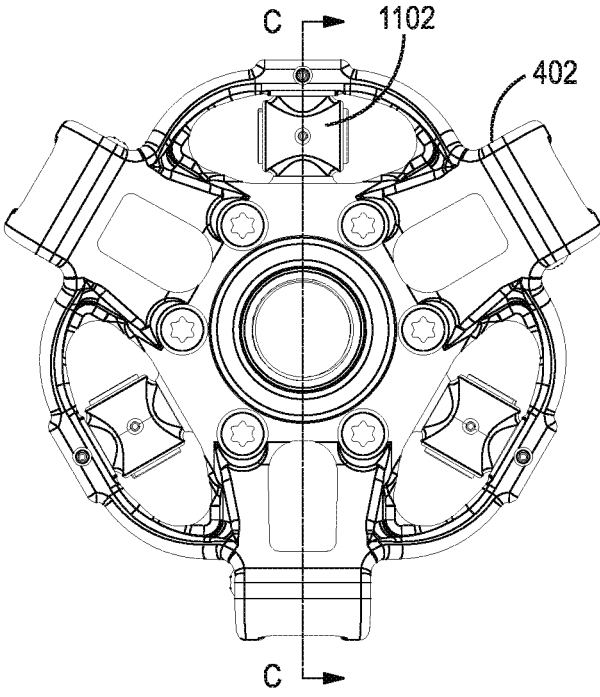
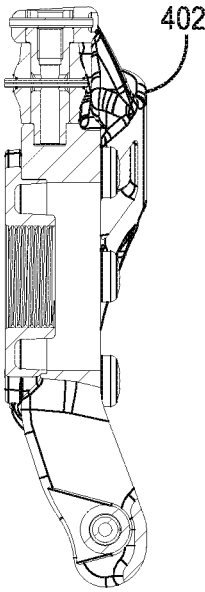


FIG. 17E



SECTION C-C

FIG. 17F

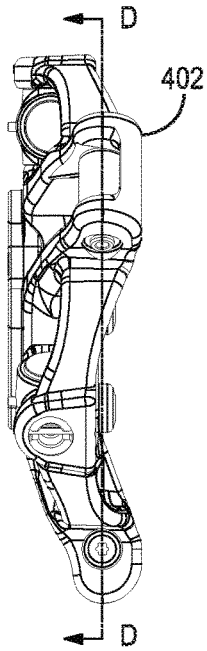
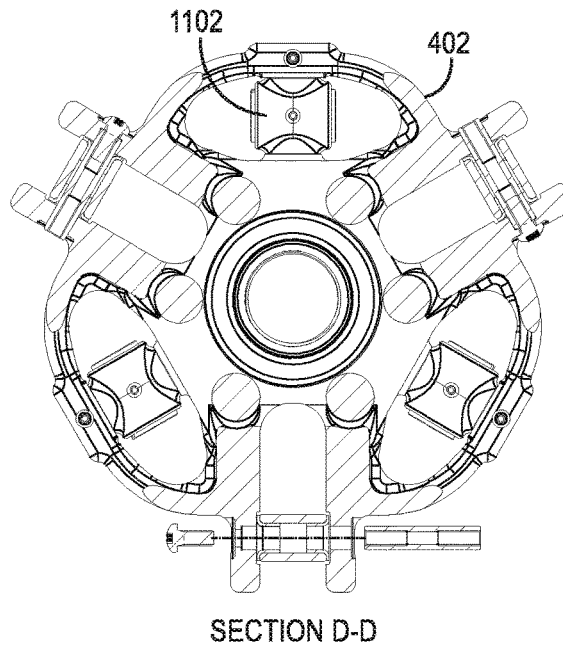


FIG. 17G



SECTION D-D  
FIG. 17H

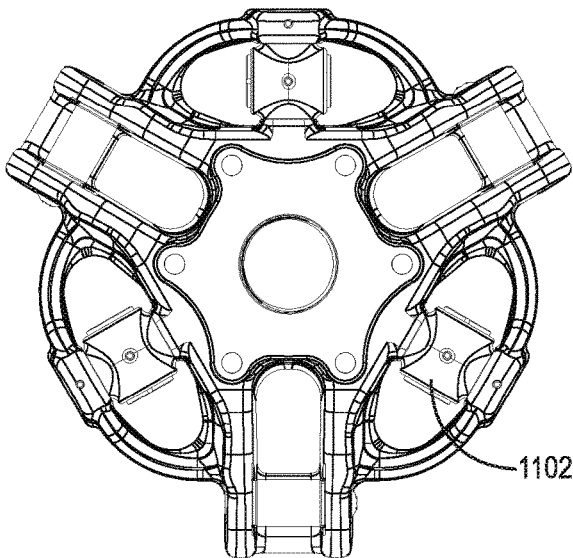


FIG. 17I

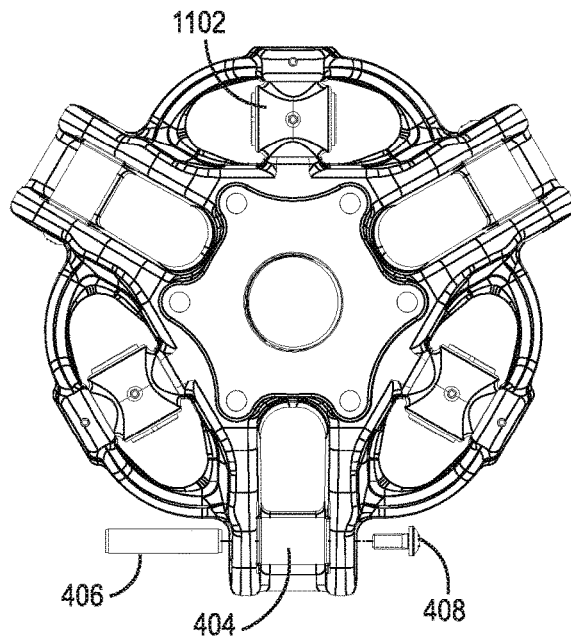


FIG. 17J

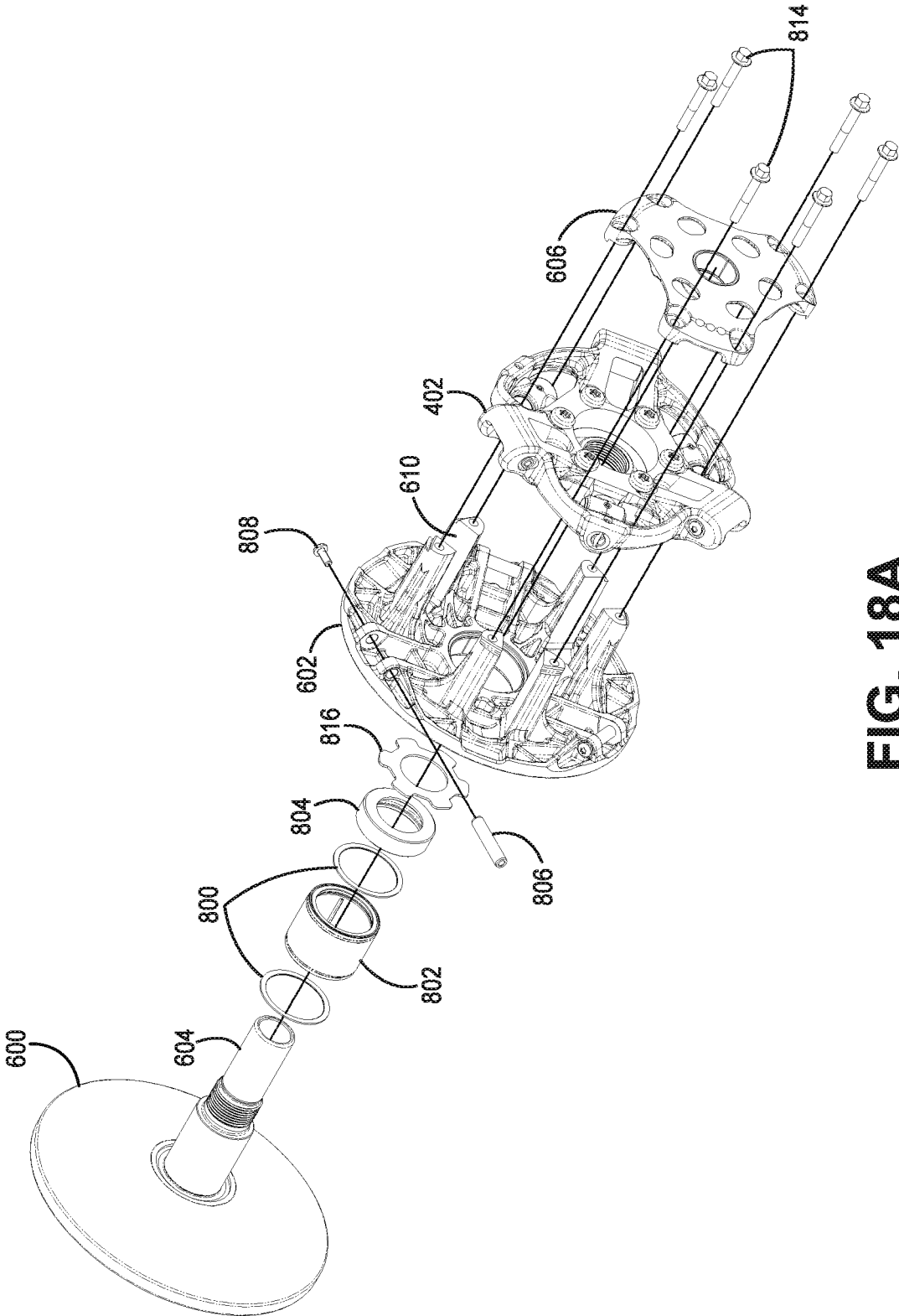
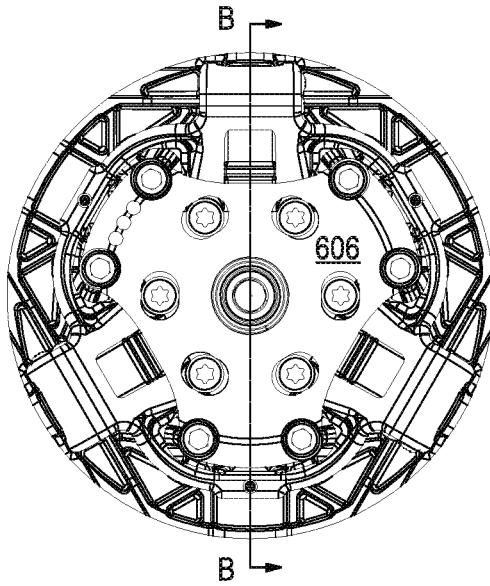
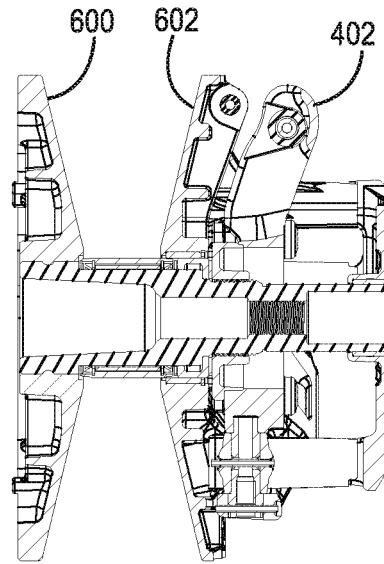


FIG. 18A

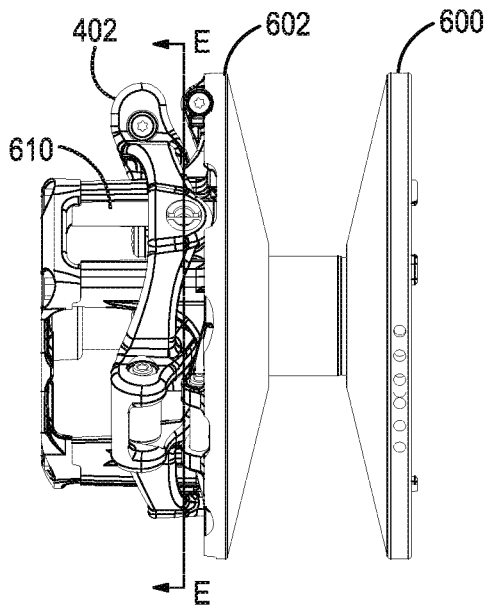


**FIG. 18B**

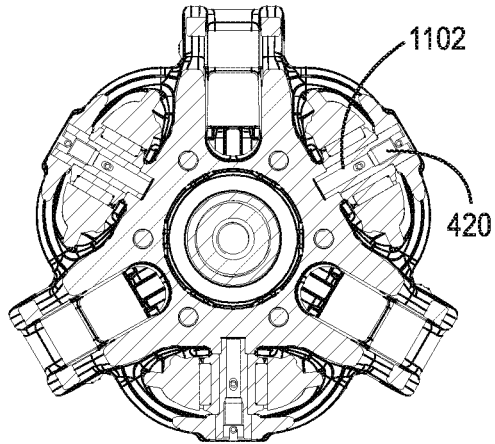


SECTION B-B

**FIG. 18C**



**FIG. 18D**



SECTION E-E

**FIG. 18E**

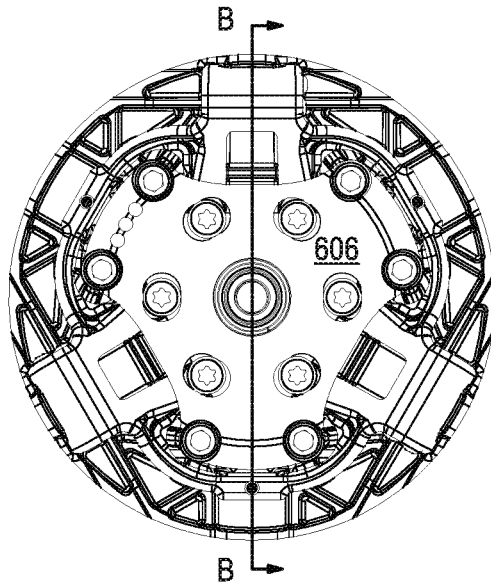
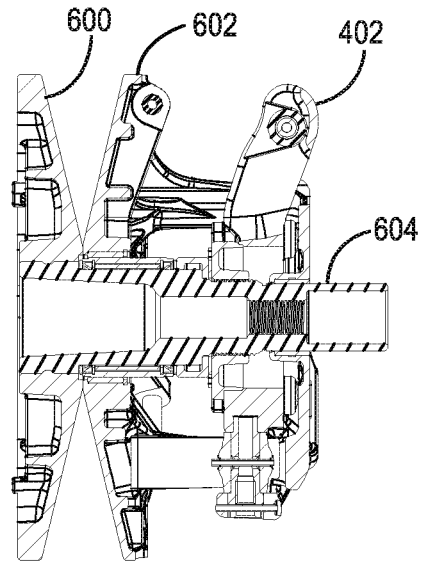


FIG. 19A



SECTION B-B

FIG. 19B

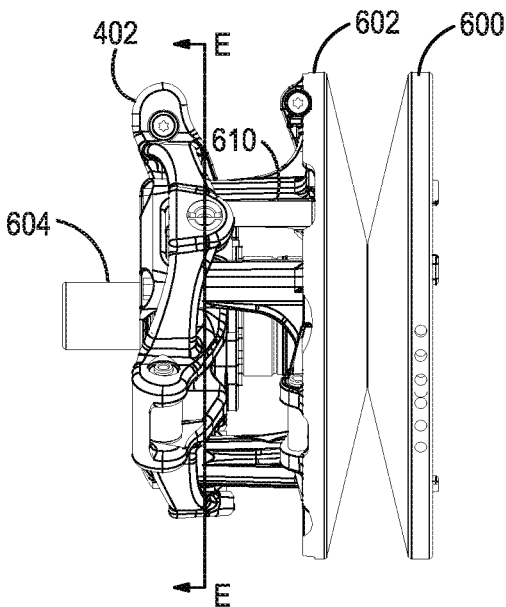
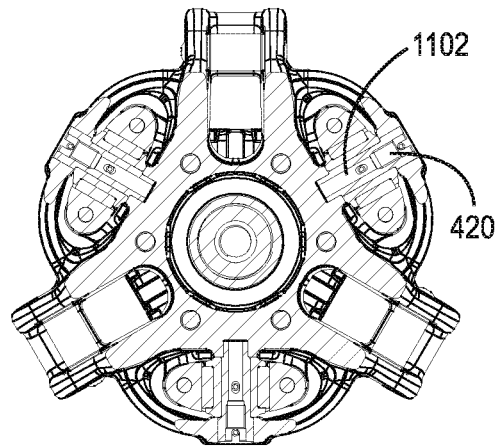


FIG. 19C



SECTION E-E

FIG. 19D

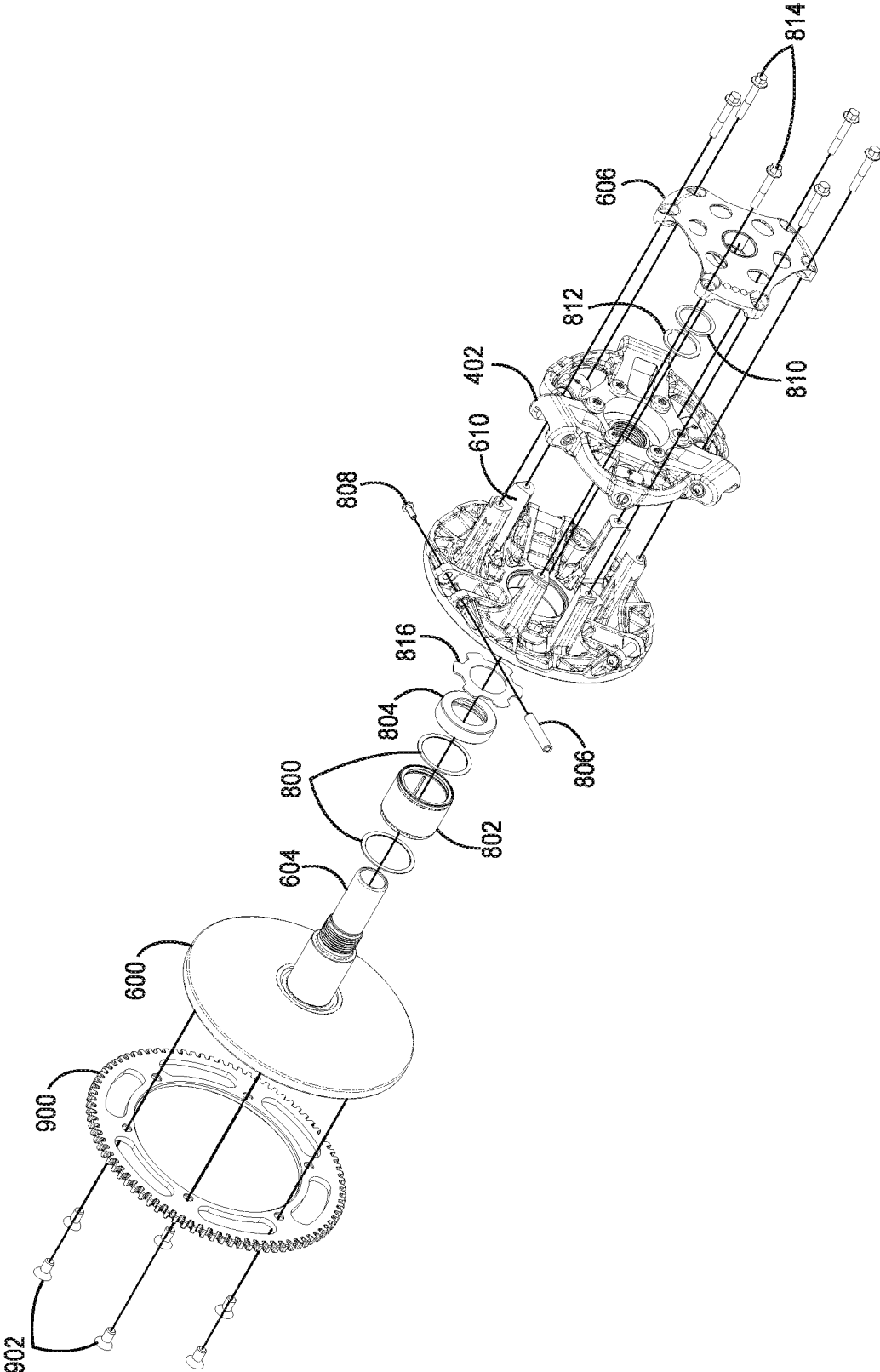


FIG. 20A

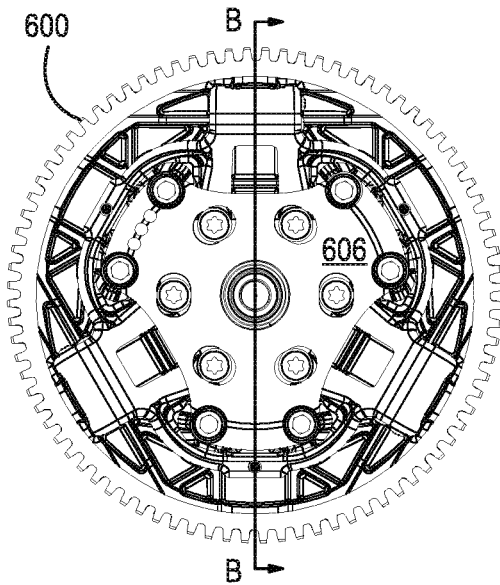
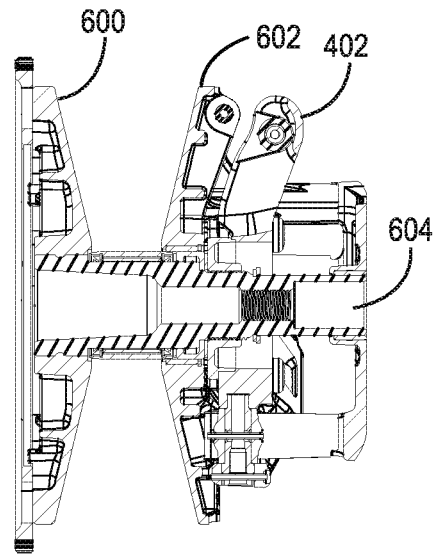


FIG. 20B



SECTION B-B

FIG. 20C

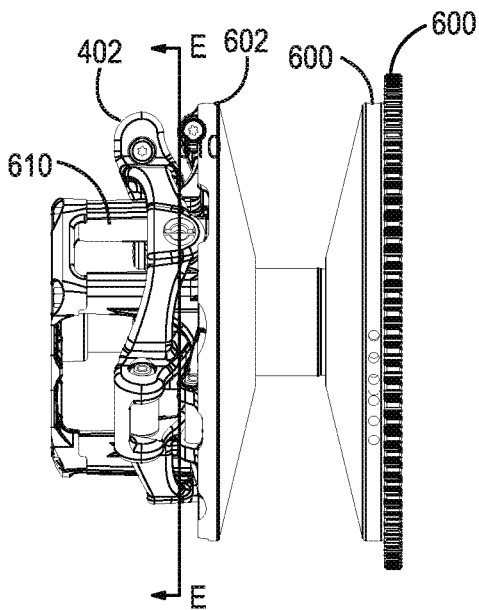
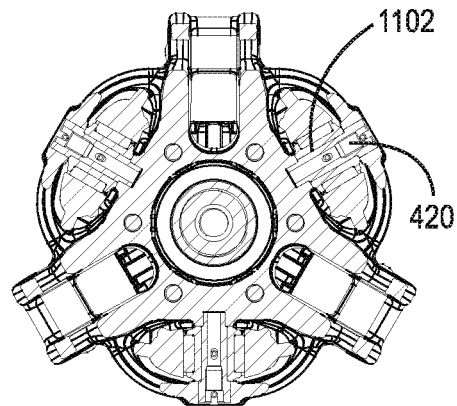


FIG. 20D



SECTION E-E

FIG. 20E

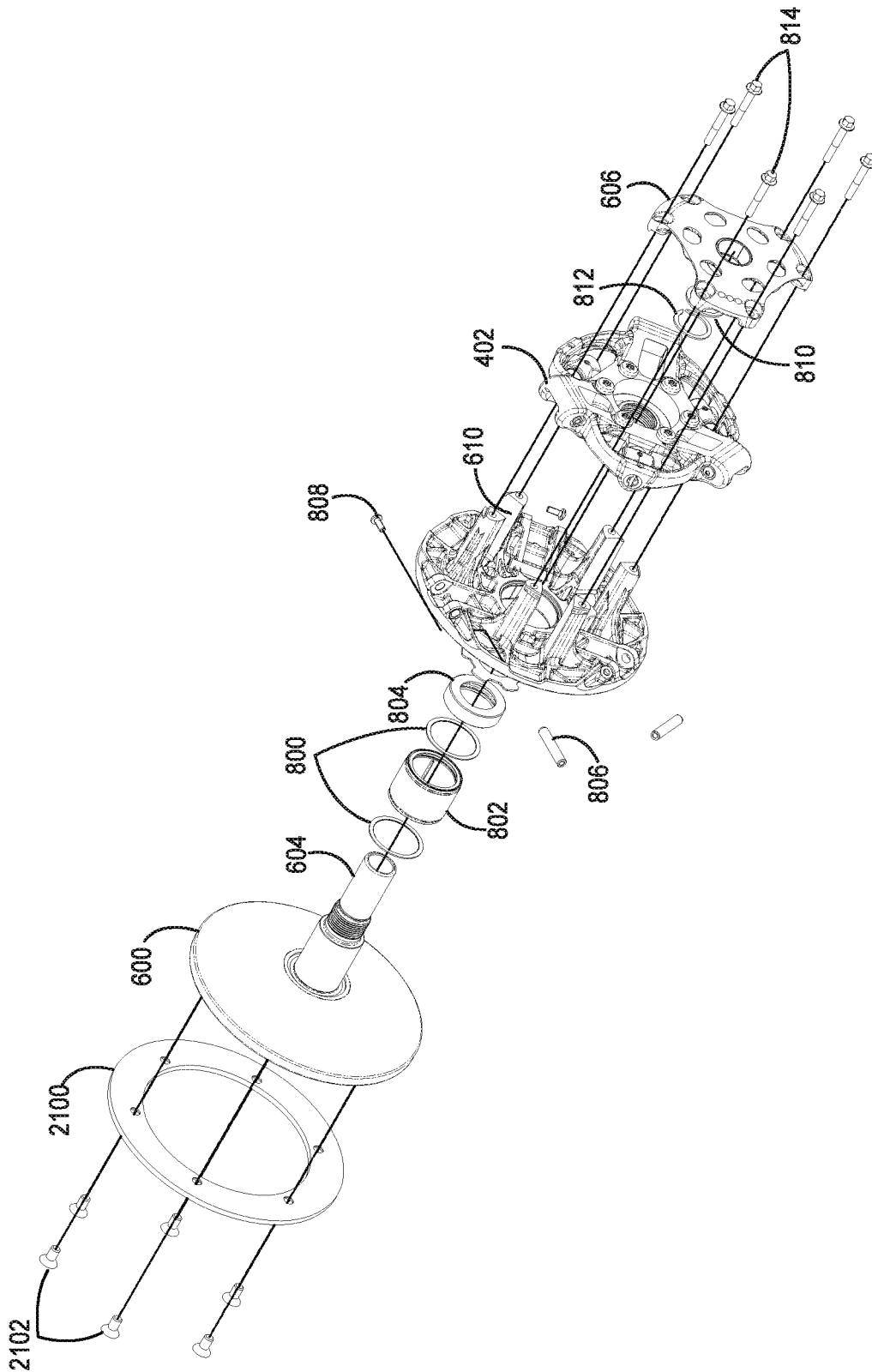
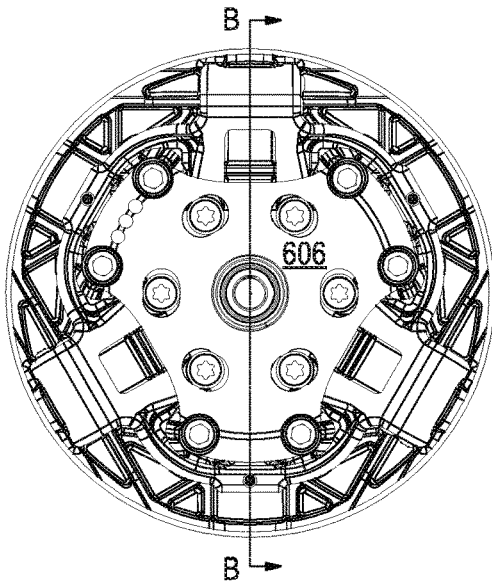
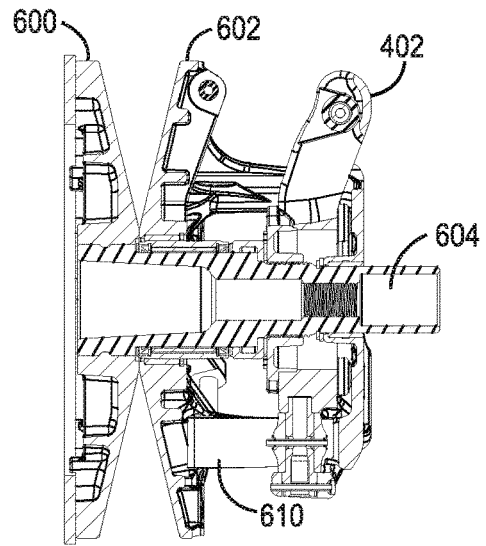


FIG. 21A

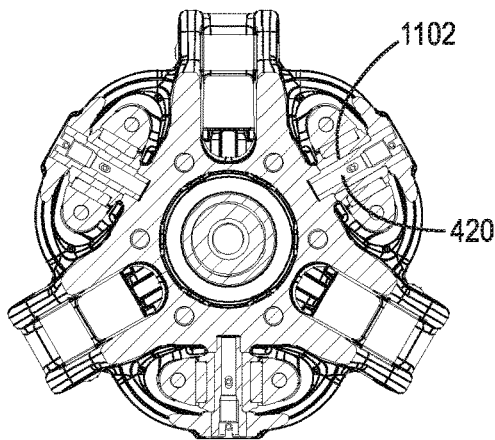


**FIG. 21B**



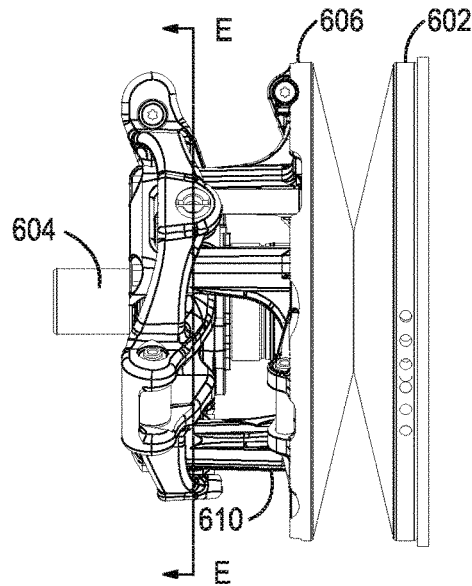
SECTION B-B

**FIG. 21C**

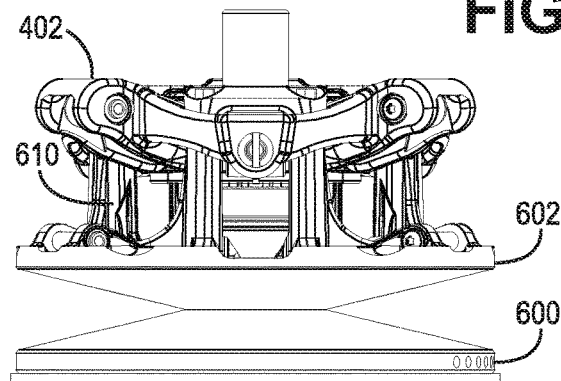


SECTION E-E

**FIG. 21D**



**FIG. 21E**



**FIG. 21F**

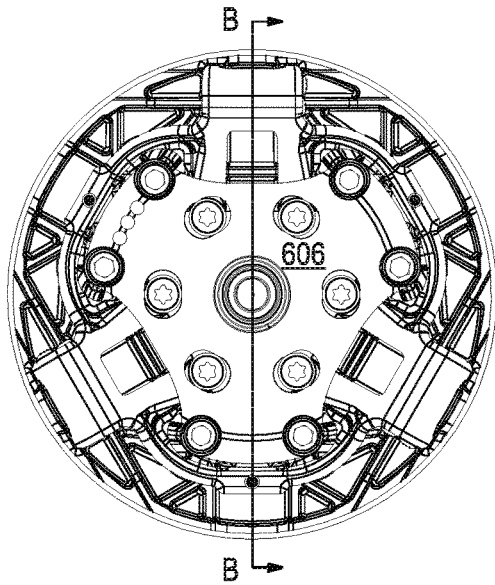
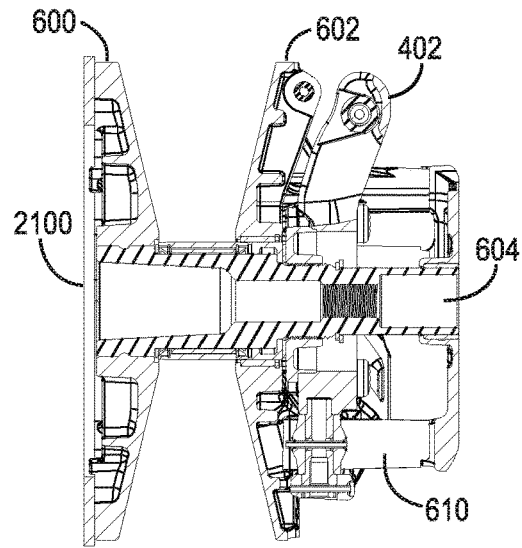


FIG. 22A



SECTION B-B  
FIG. 22B

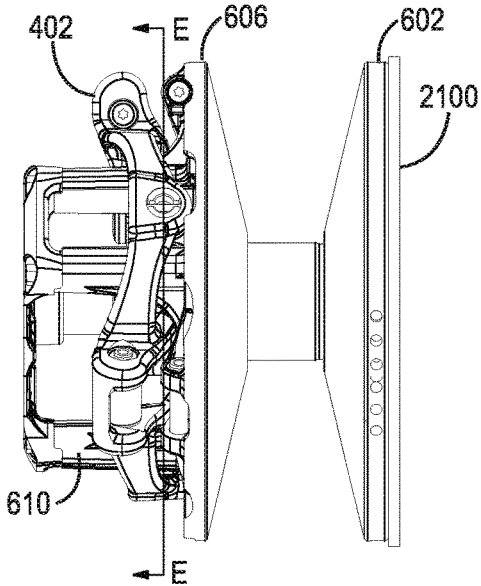
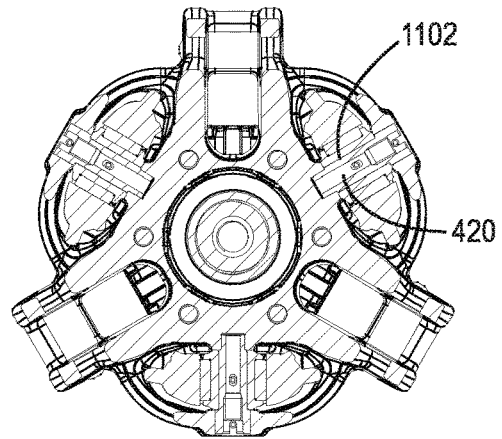


FIG. 22C



SECTION E-E  
FIG. 22D

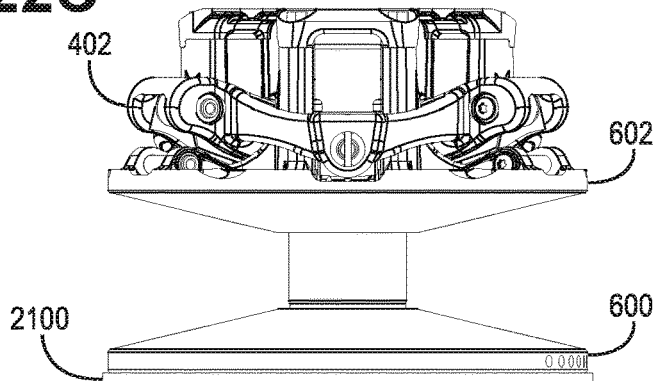


FIG. 22E

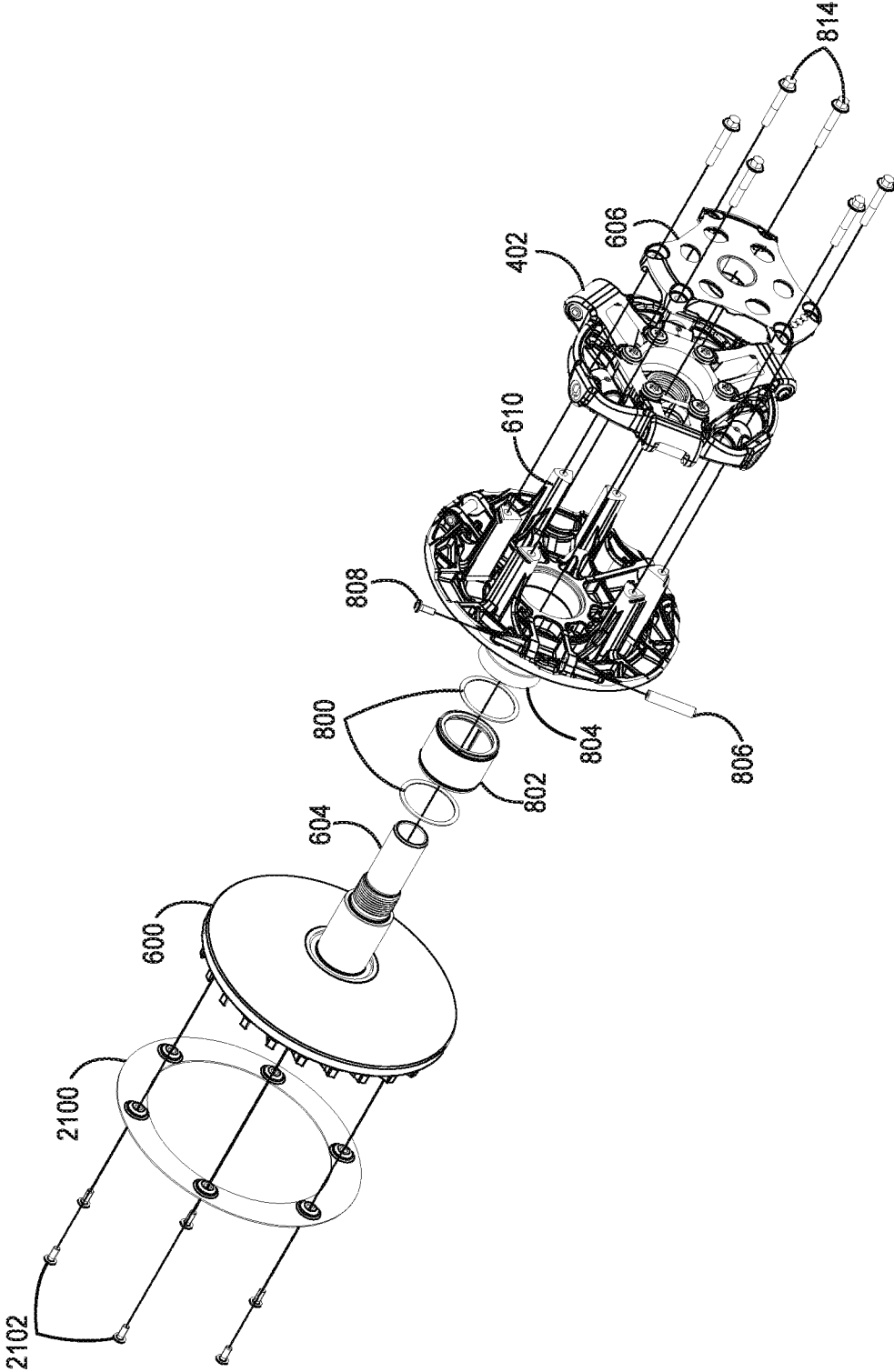


FIG. 23A

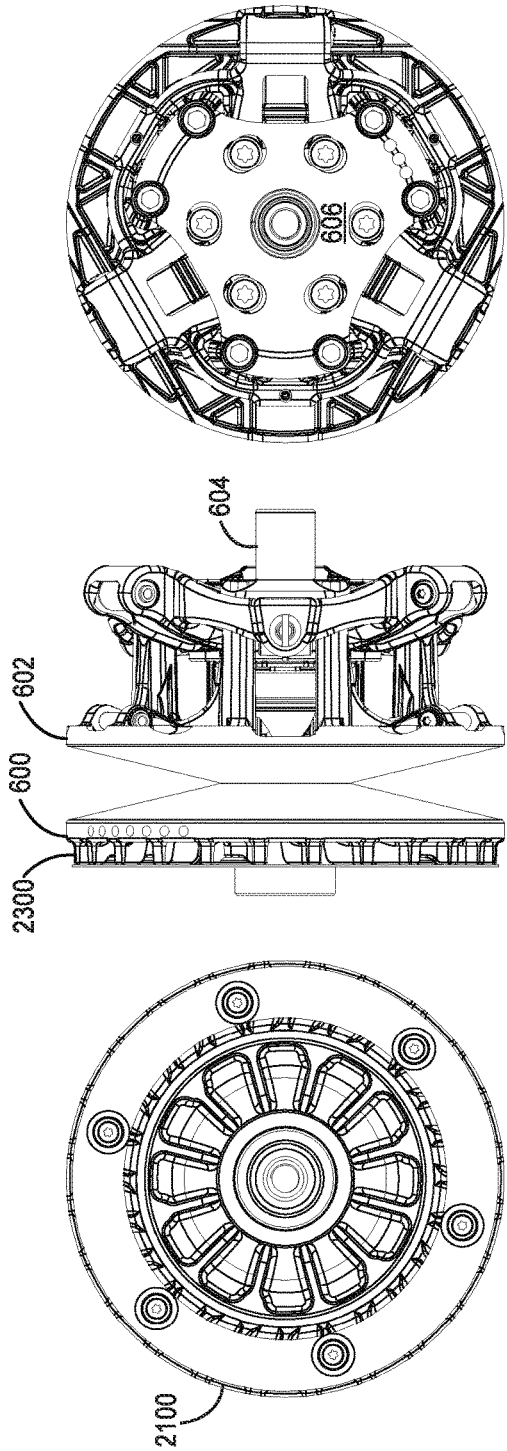
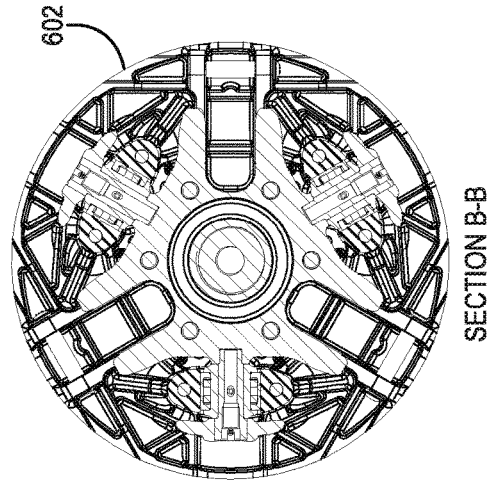


FIG. 23D

FIG. 23C

FIG. 23B



SECTION B-B

FIG. 23F

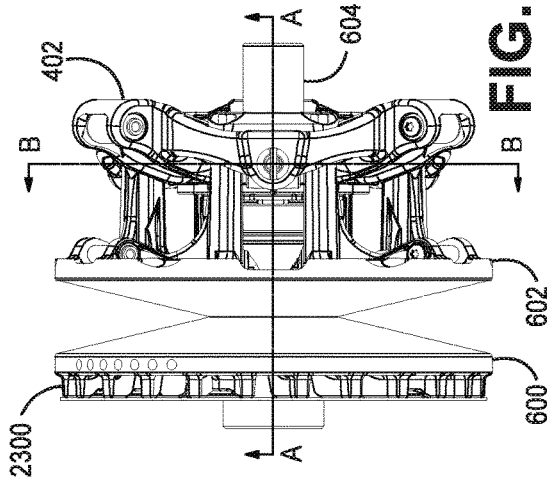


FIG. 23E

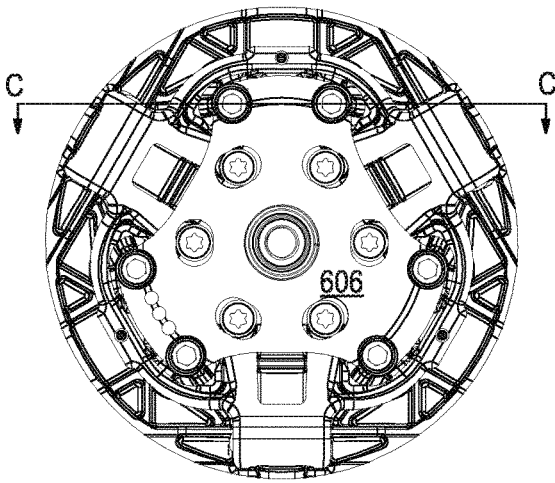


FIG. 23G

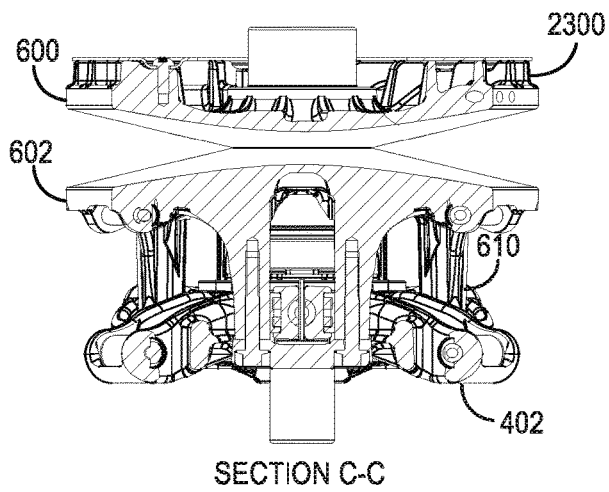


FIG. 23H

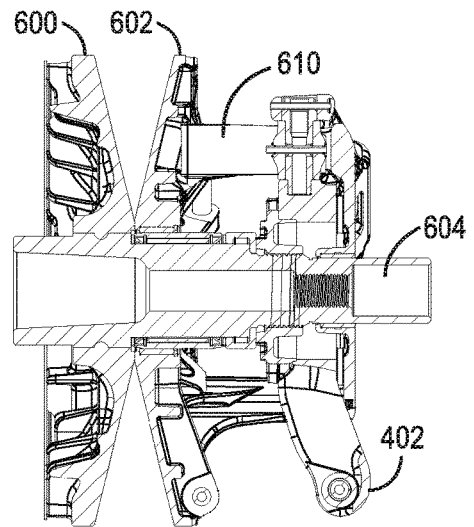


FIG. 23I

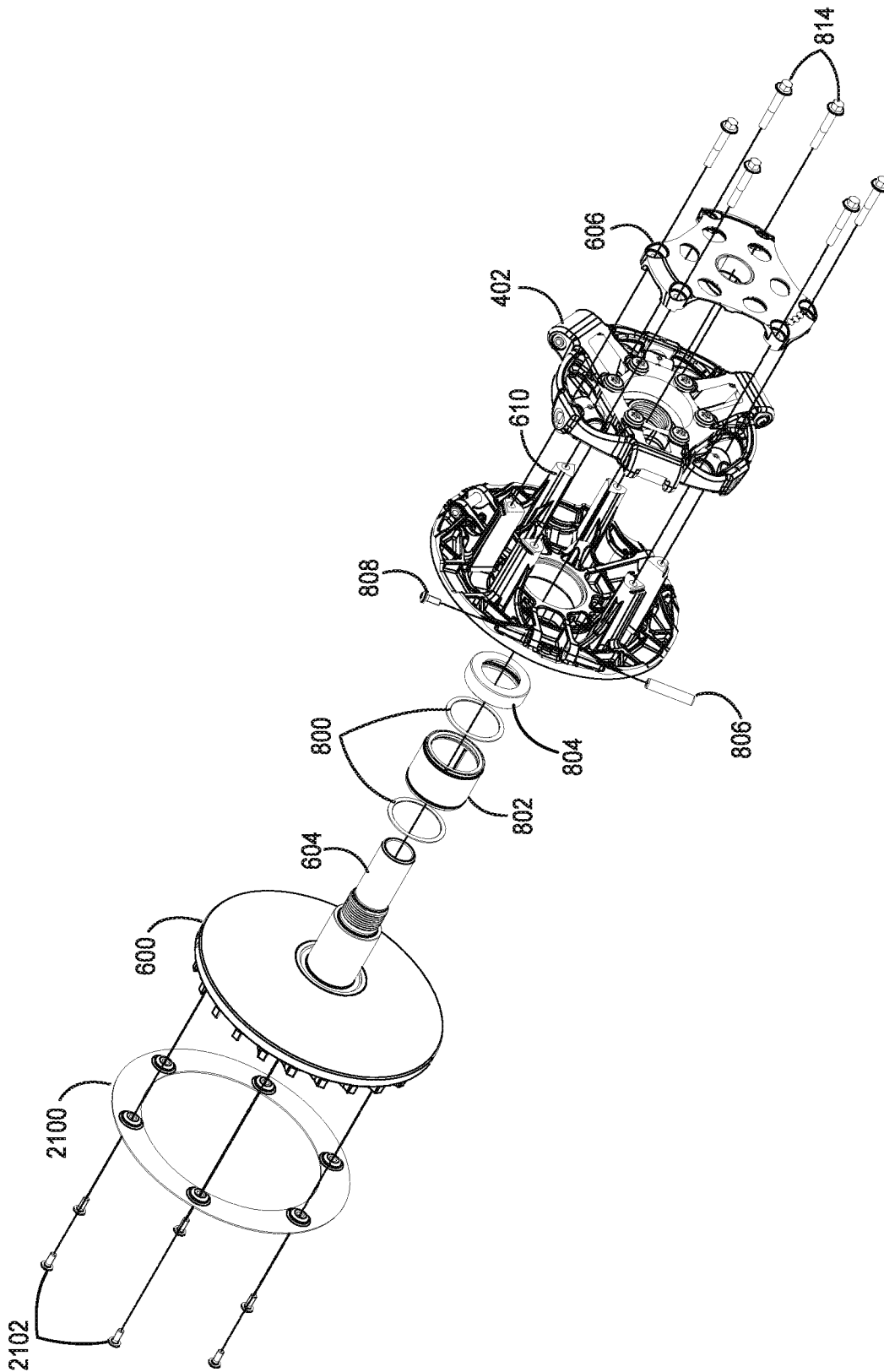


FIG. 24A

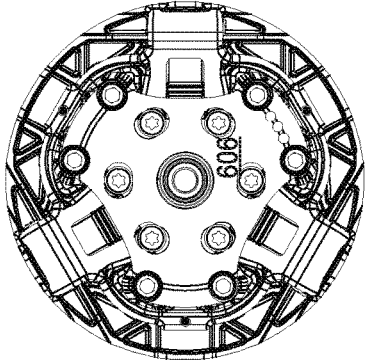


FIG. 24D

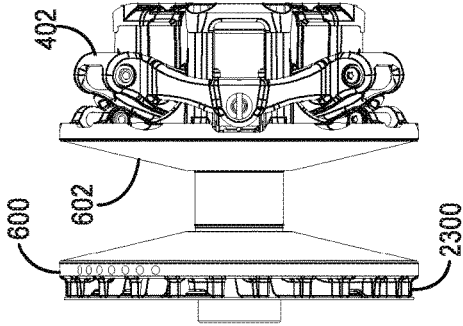


FIG. 24C

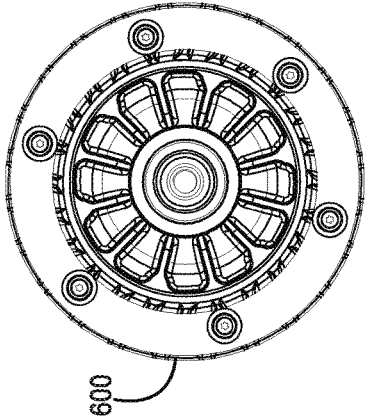
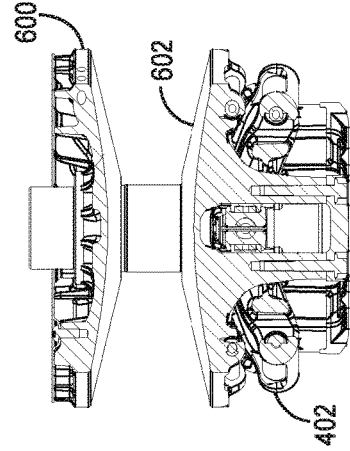
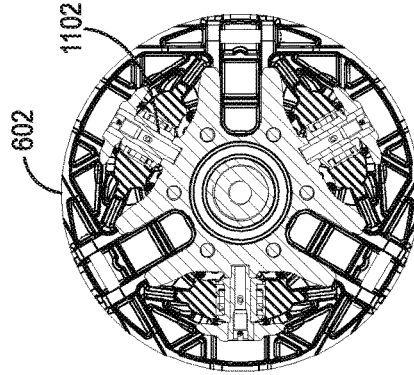


FIG. 24B



SECTION C-C  
FIG. 24G



SECTION B-B  
FIG. 24F

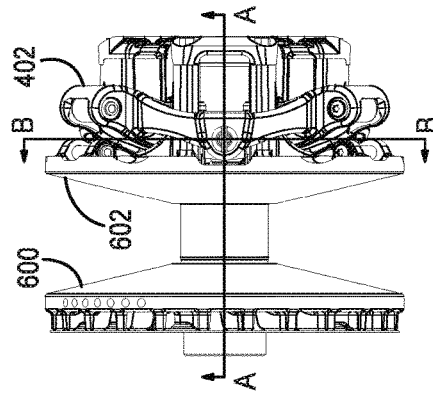


FIG. 24E

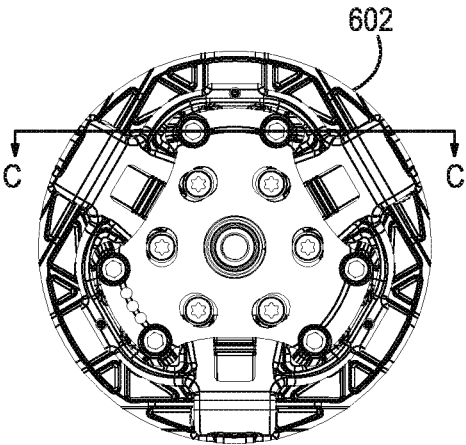
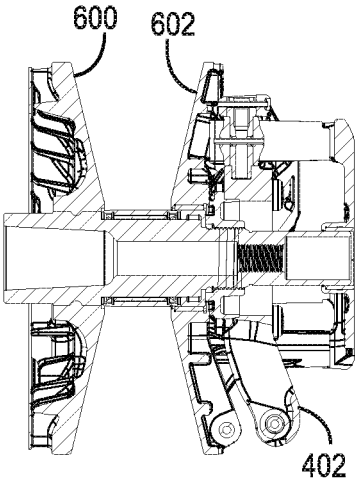


FIG. 24H



SECTION A-A

FIG. 24I

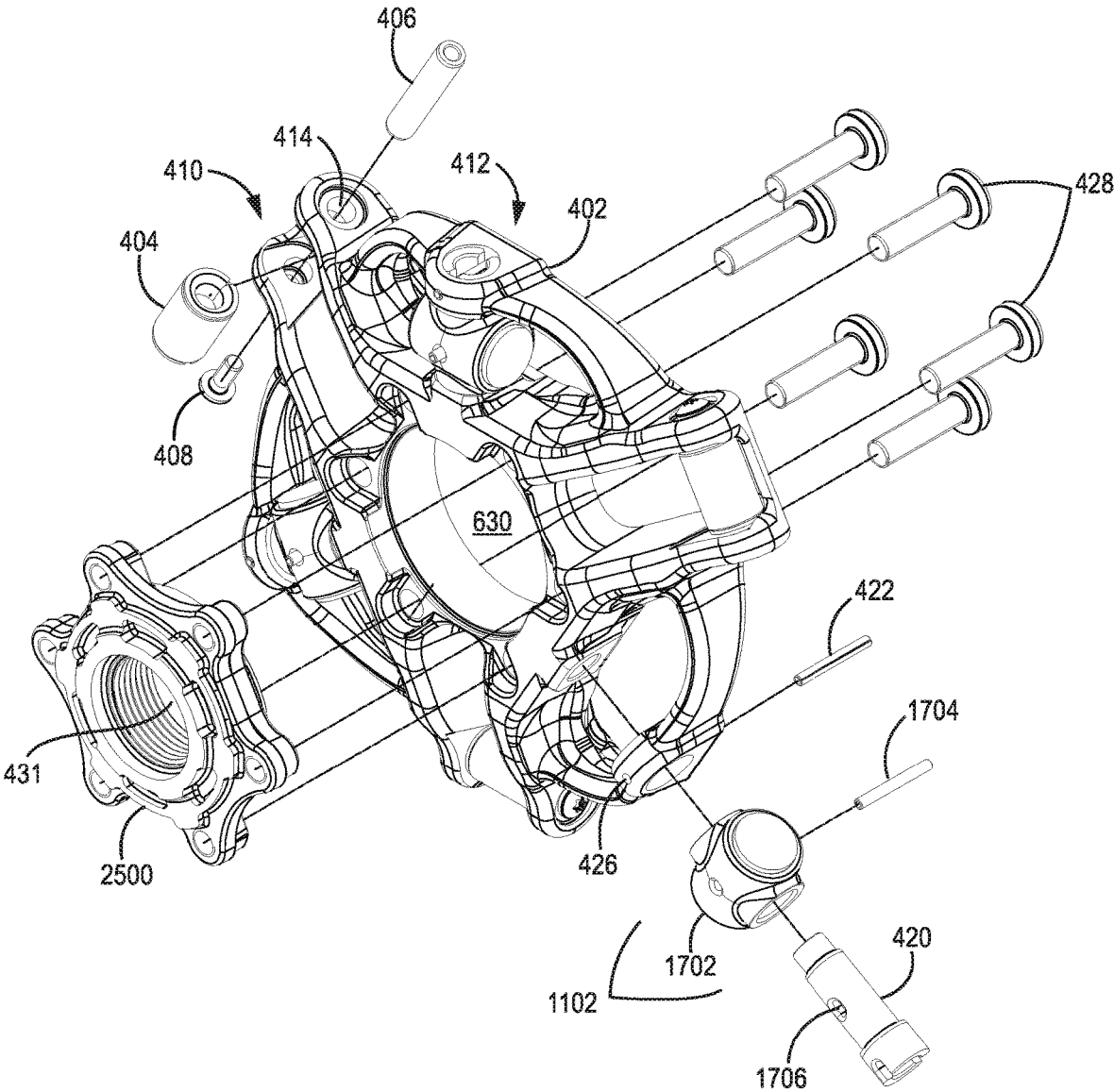
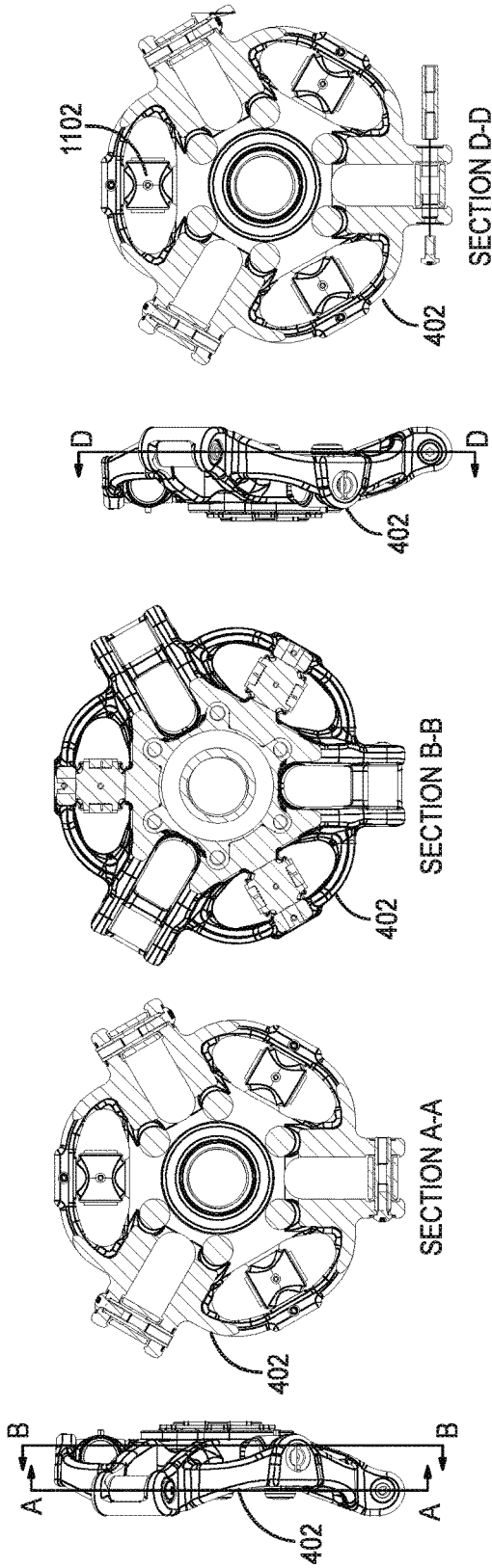
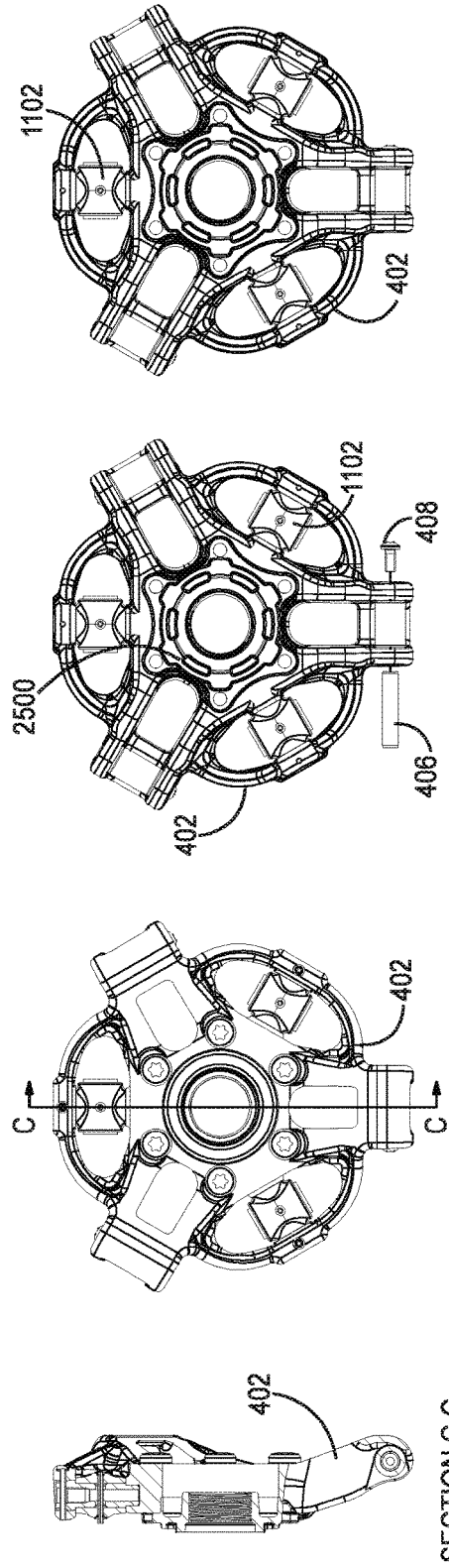


FIG. 25



**FIG. 26A** **FIG. 26B** **FIG. 26C** **FIG. 26D** **FIG. 26E**



**FIG. 26F** **FIG. 26G** **FIG. 26H** **FIG. 26I**

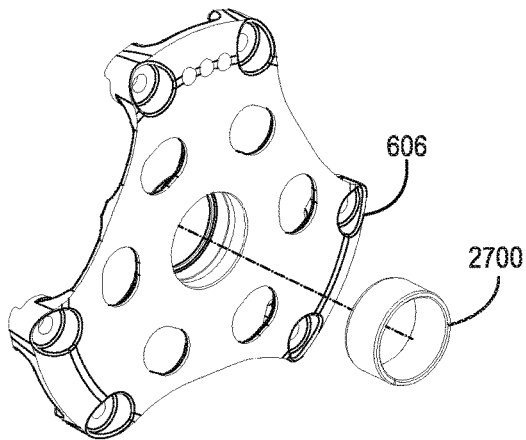


FIG. 27A

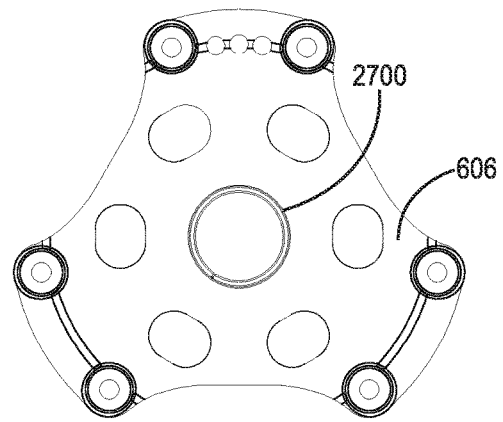


FIG. 27B

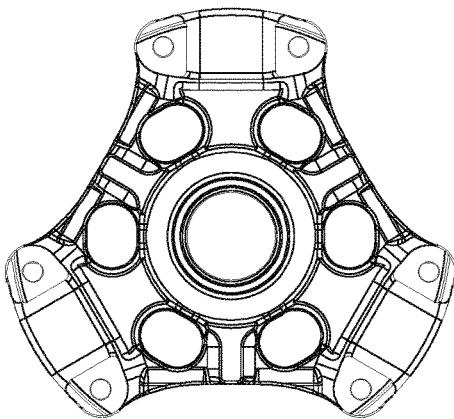


FIG. 27C

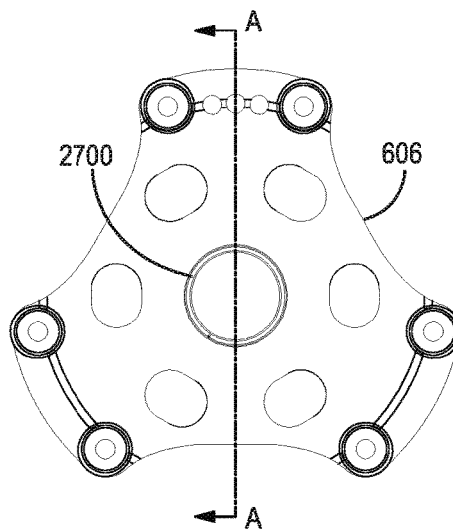
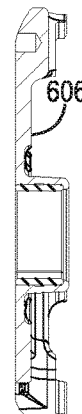


FIG. 27D



SECTION A-A  
FIG. 27E

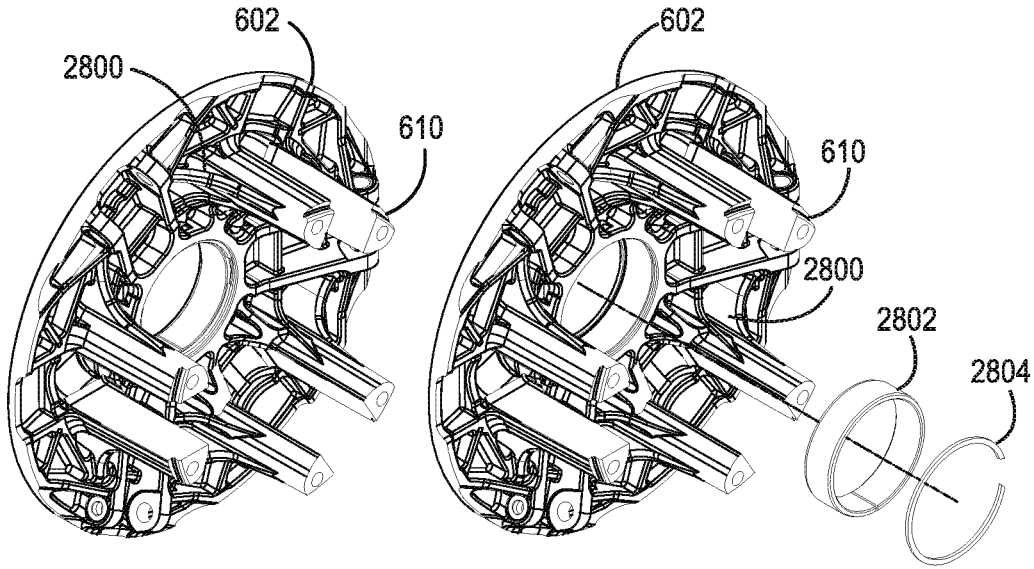


FIG. 28A

FIG. 28B

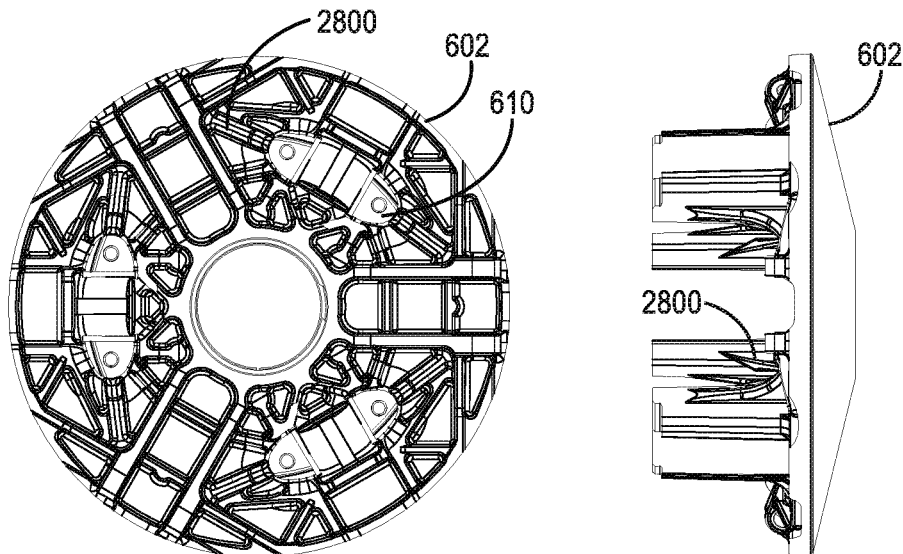


FIG. 28C

FIG. 28D

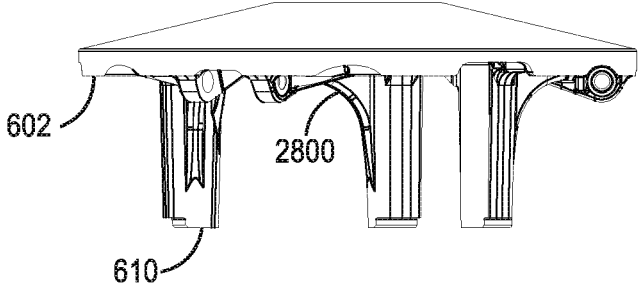


FIG. 28E

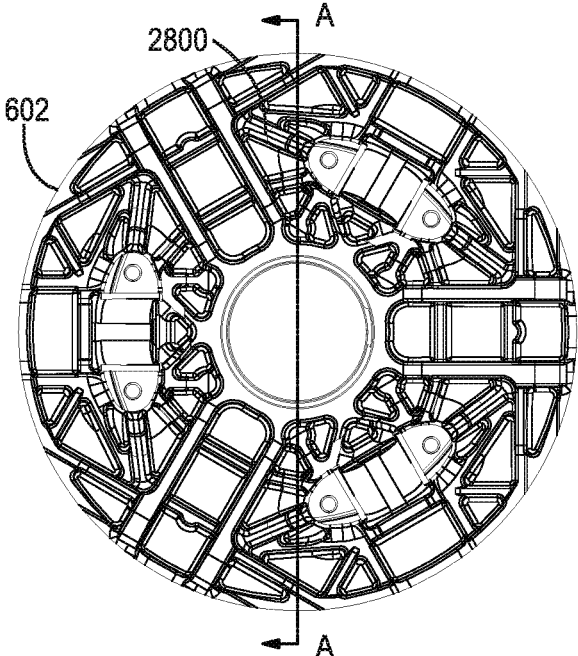
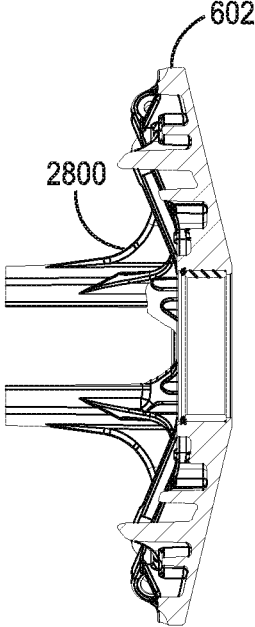
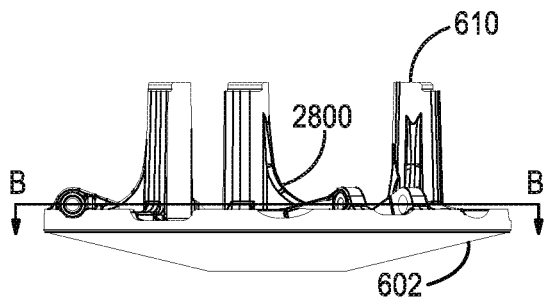


FIG. 28F

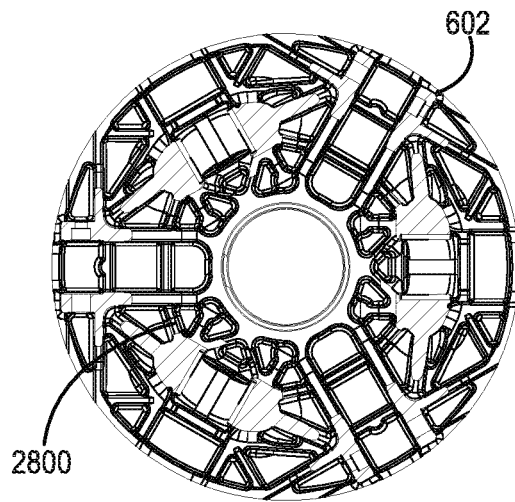


SECTION A-A

FIG. 28G

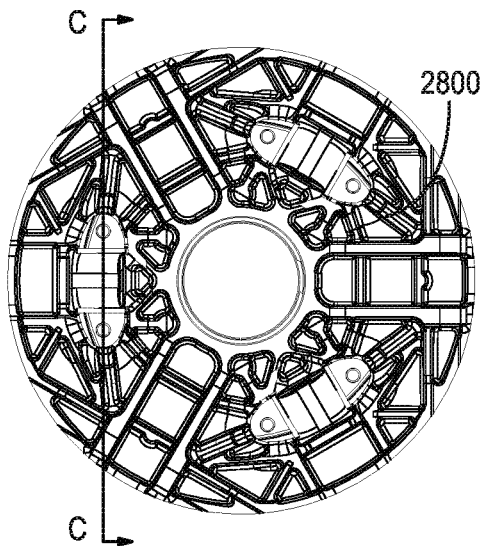


**FIG. 28H**

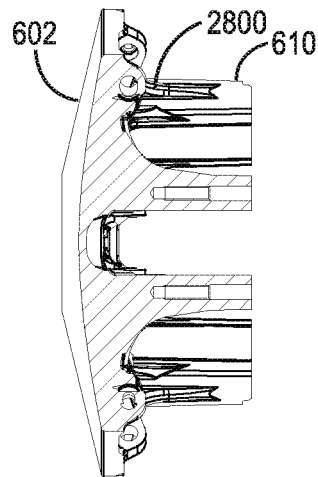


SECTION B-B

**FIG. 28I**



**FIG. 28J**



SECTION C-C

**FIG. 28K**

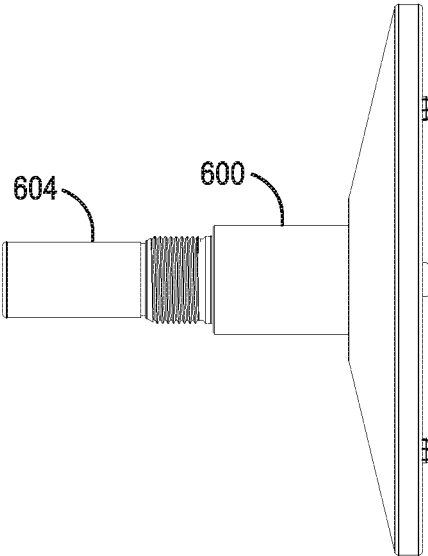


FIG. 29A

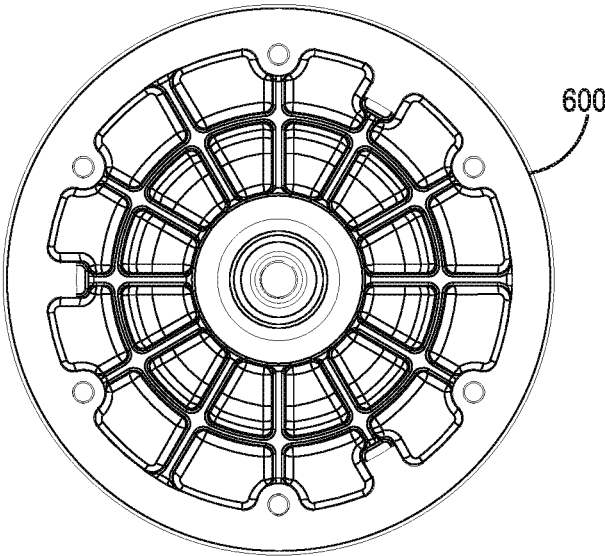


FIG. 29B

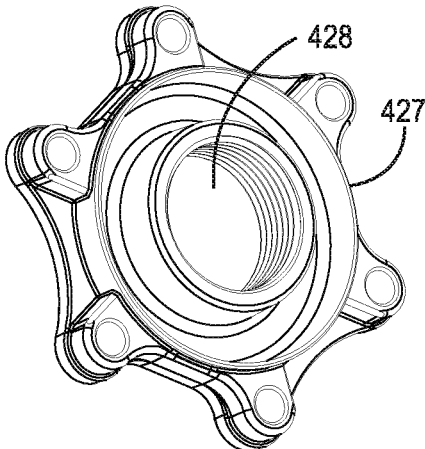


FIG. 30A

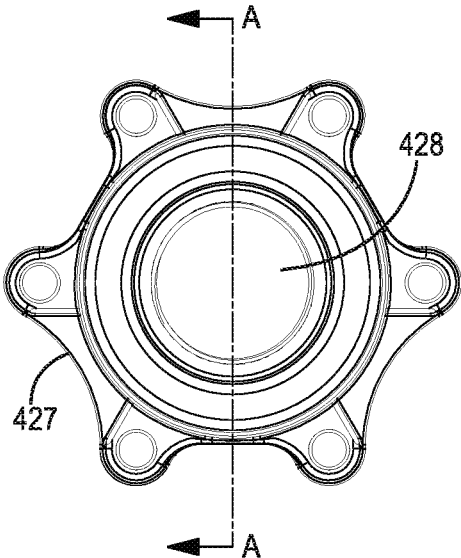


FIG. 30B

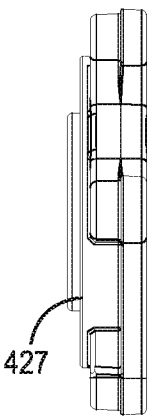


FIG. 30C

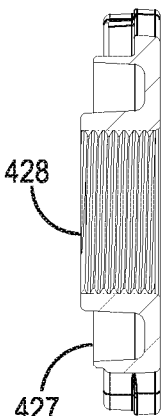


FIG. 30D

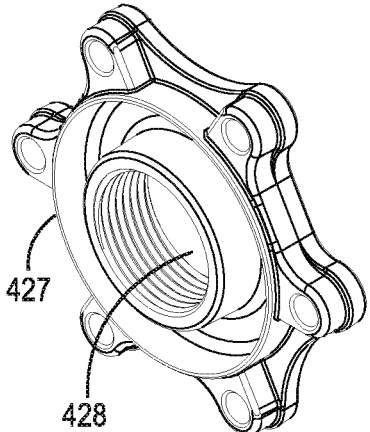


FIG. 30E

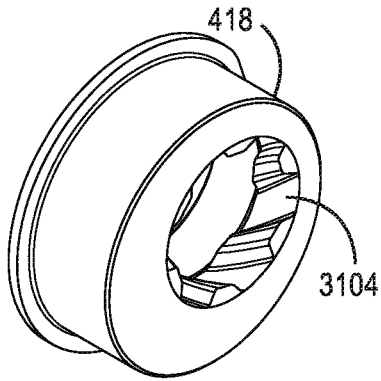


FIG. 31A

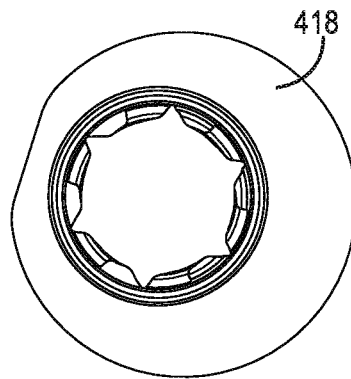


FIG. 31B

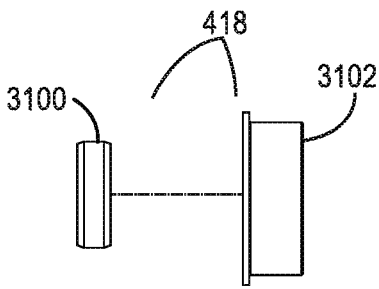


FIG. 31C

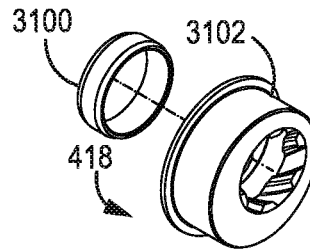


FIG. 31D

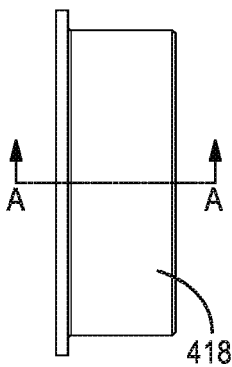


FIG. 31E

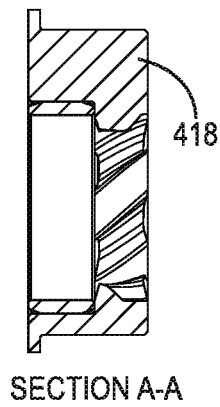


FIG. 31F

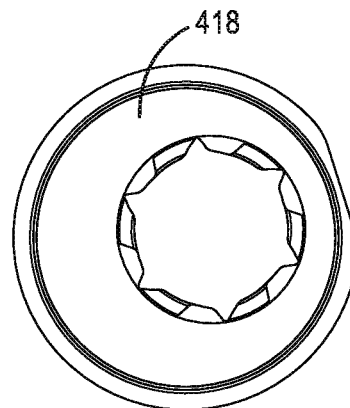
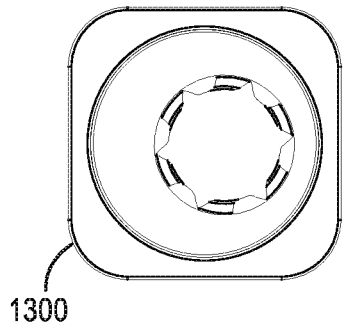
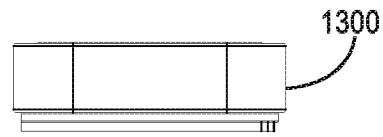


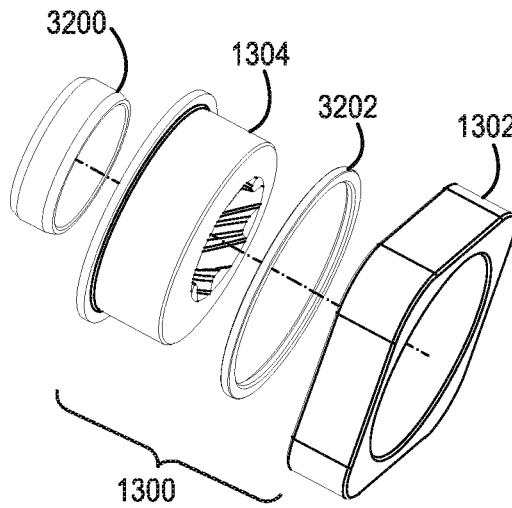
FIG. 31G



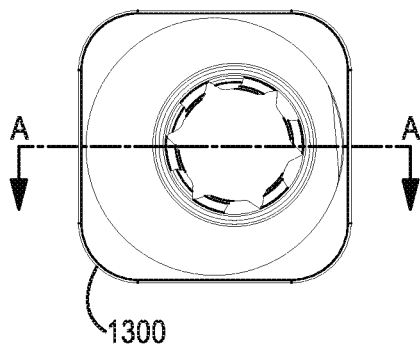
**FIG. 32A**



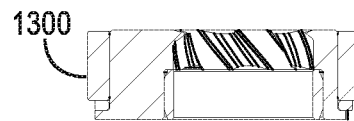
**FIG. 32B**



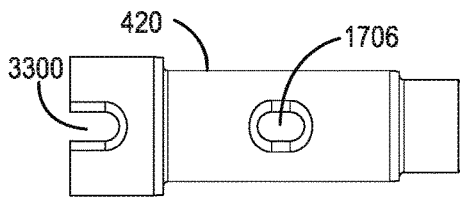
**FIG. 32C**



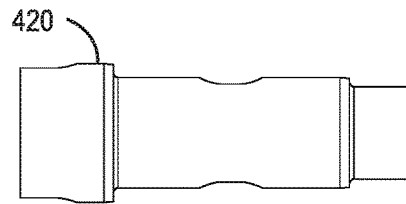
**FIG. 32D**



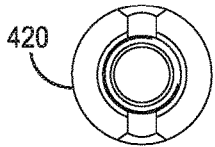
SECTION A-A  
**FIG. 32E**



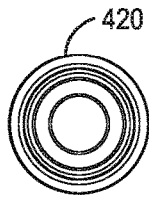
**FIG. 33A**



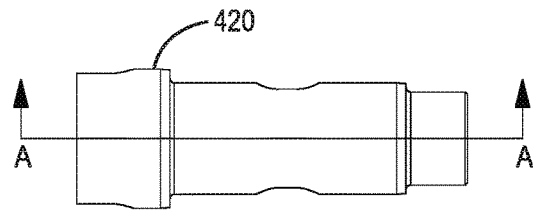
**FIG. 33B**



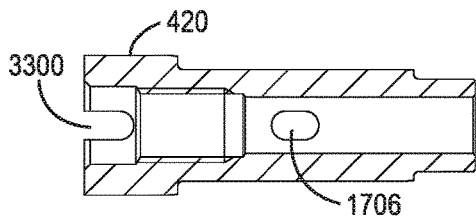
**FIG. 33C**



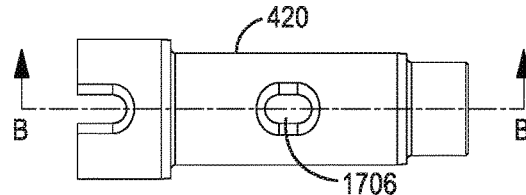
**FIG. 33D**



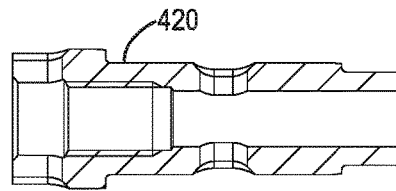
**FIG. 33E**



**FIG. 33F**

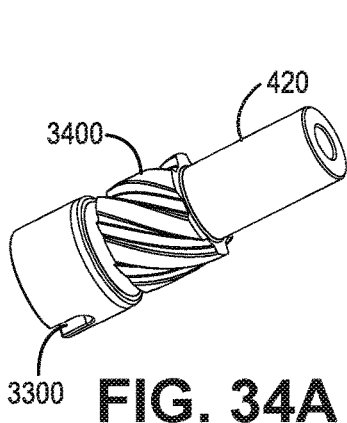


**FIG. 33G**

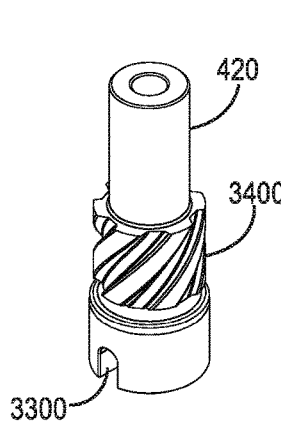


SECTION B-B

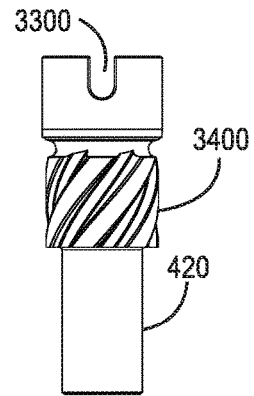
**FIG. 33H**



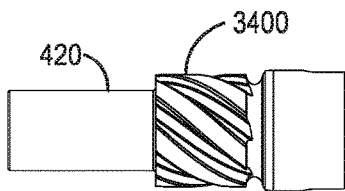
**FIG. 34A**



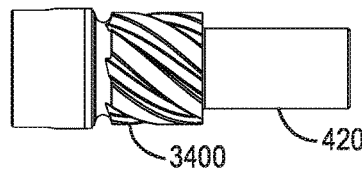
**FIG. 34B**



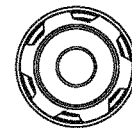
**FIG. 34C**



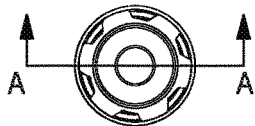
**FIG. 34D**



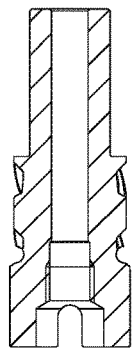
**FIG. 34E**



**FIG. 34F**

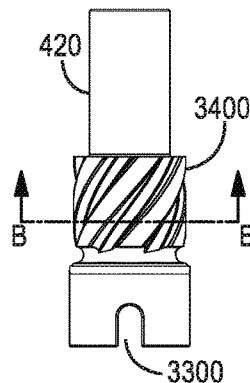


**FIG. 34G**

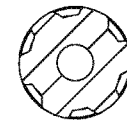


SECTION A-A

**FIG. 34H**

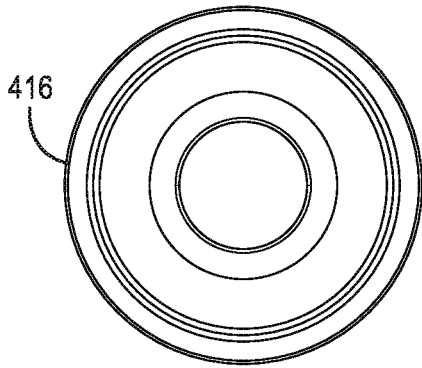


**FIG. 34I**

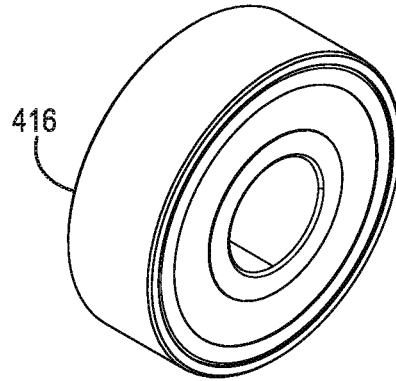


SECTION B-B

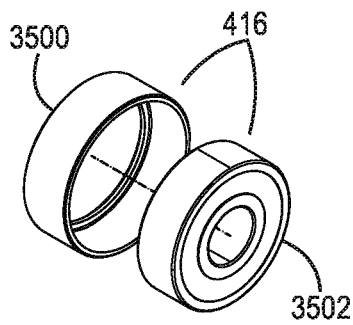
**FIG. 34J**



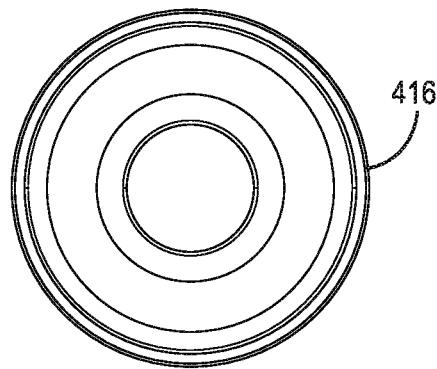
**FIG. 35A**



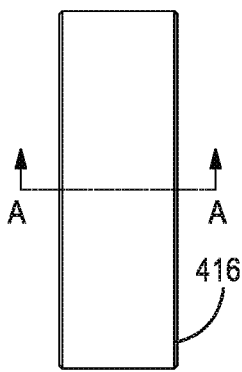
**FIG. 35B**



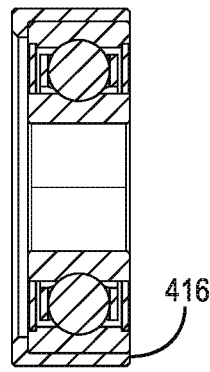
**FIG. 35C**



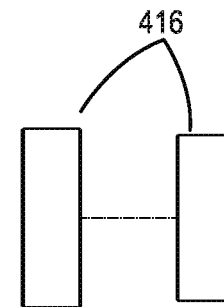
**FIG. 35D**



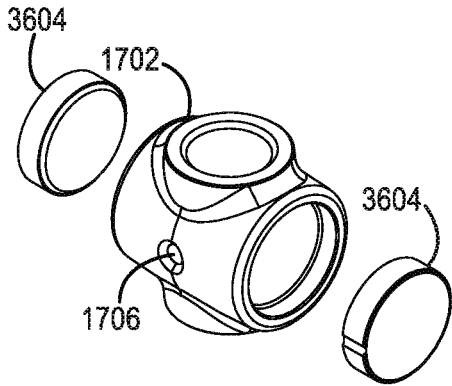
**FIG. 35E**



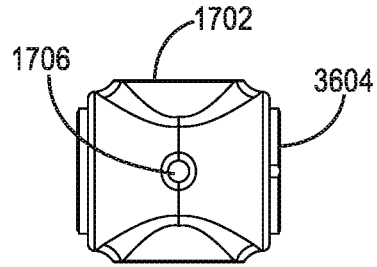
**FIG. 35F**



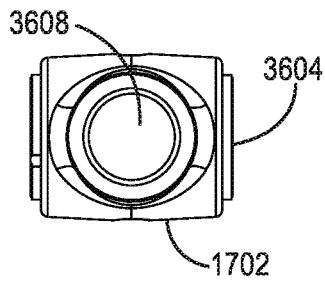
**FIG. 35G**



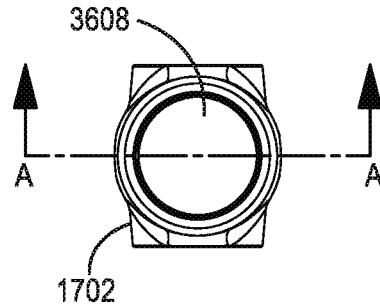
**FIG. 36A**



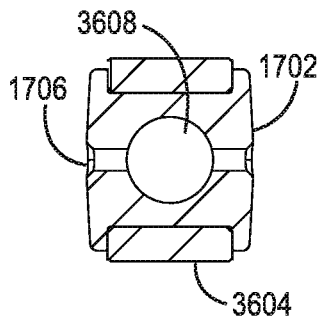
**FIG. 36B**



**FIG. 36C**

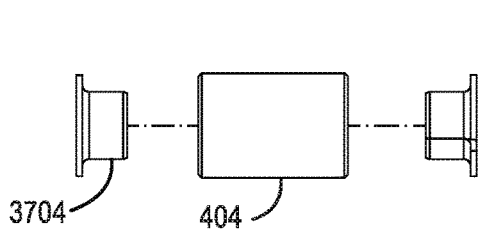


**FIG. 36D**

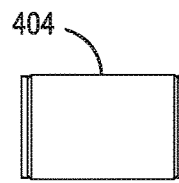


SECTION A-A

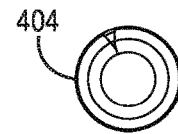
**FIG. 36E**



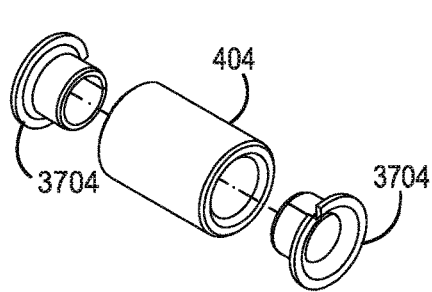
**FIG. 37A**



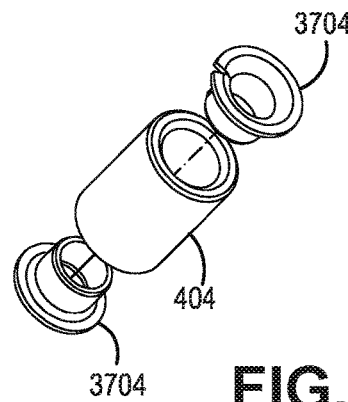
**FIG. 37B**



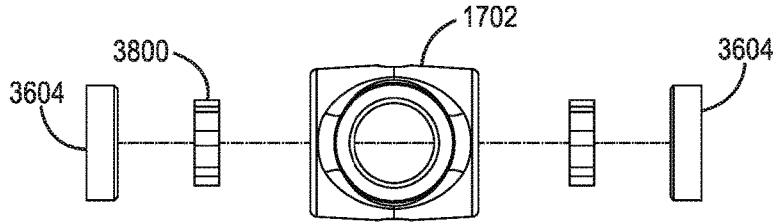
**FIG. 37C**



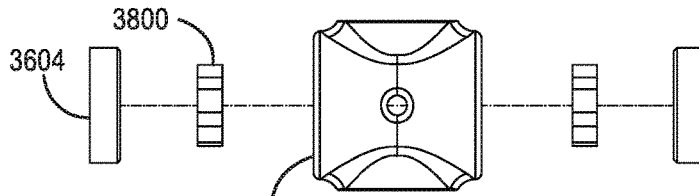
**FIG. 37D**



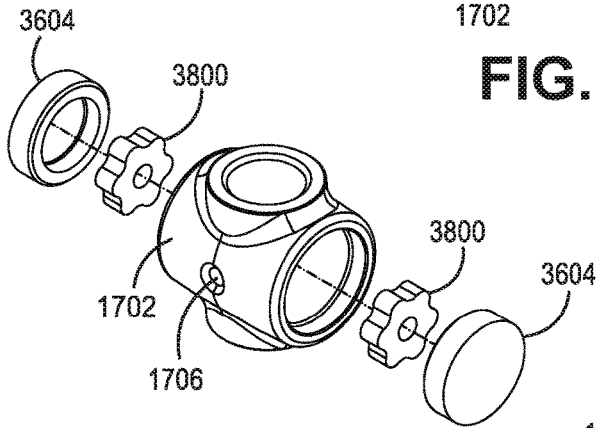
**FIG. 37E**



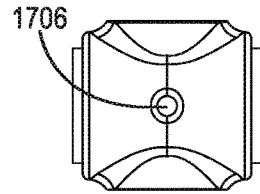
**FIG. 38A**



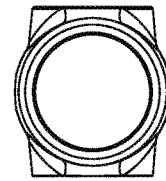
**FIG. 38B**



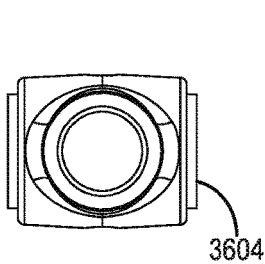
**FIG. 38C**



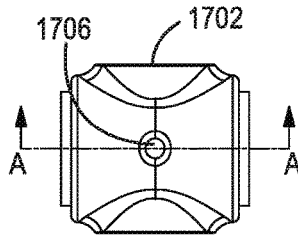
**FIG. 38D**



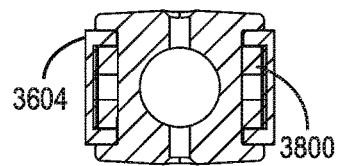
**FIG. 38E**



**FIG. 38F**



**FIG. 38G**



SECTION A-A  
**FIG. 38H**

1

**CONTINUOUSLY VARIABLE  
TRANSMISSION FOR RECREATIONAL  
VEHICLES AND RELATED COMPONENTS**

BACKGROUND

Snowmobiles are popular land vehicles used as transportation vehicles or as recreational vehicles in cold and snowy conditions. Generally, snowmobiles are available for various applications such as deep snow, high performance, luxury touring, and trail riding, for example. In general, a snowmobile has a chassis on or around which the various components of the snowmobile are assembled. Typical snowmobiles include one or more skis for steering, a seat, handlebars, and an endless track for propulsion mounted to a central chassis. The engine drives a ground-engaging endless track disposed in a longitudinally extending drive tunnel. The skis serve to facilitate steering as well as to provide flotation of the front of the snowmobile over the snow in which it is operated. A handlebar assembly, positioned forward of the seat, is operatively linked to the skis for steering the snowmobile. The skis may be pivoted to steer the snowmobile, for example, by turning the handlebars.

At least some snowmobile frames include a tunnel and a front chassis portion which retains the power train, and a front suspension that mounts skis to the frame. A drive shaft is typically mounted to the front chassis portion and includes drive sprockets for powering a belt. A chain case, belt drive case, or gear box is also typically provided to transfer power from an engine or CVT (continuously variable transmission) to the drive shaft. A typical snowmobile may include a drivetrain with a drive shaft and an upper jack shaft that drives the drive sprocket(s) through the chain case, belt drive case, or gear box. CVTs are also utilized for snow bikes, motorcycles, and all-terrain vehicles (ATVs).

SUMMARY

Embodiments of the present disclosure describe a drive pulley for a continuously variable transmission including a stationary sheave with a stationary shaft, a movable sheave axially movable relative to the stationary sheave and in contact with the stationary shaft; a spider in contact with at least the moveable sheave and stationary shaft; a spring member, biasing the movable sheave axially away from the stationary sheave; at least one centrifugal actuator including an arm pivotally connected to one of the movable sheave and the spider, the arm pivoting away from the one of the movable sheave and the spider as a speed of rotation of the drive pulley increases, the arm pushing against another one of the movable sheave and the spider as the arm pivots away from the one of the movable sheave and the spider, thereby moving the movable sheave axially toward the stationary sheave, the at least one centrifugal actuator being disposed radially outward of the stationary sheave shaft; and a torque transfer assembly operatively connected to at least one of the spider and the movable sheave, the torque transfer assembly transferring torque between the spider and the movable sheave, the torque transfer assembly including, a torque bearing assembly and at least one roller assembly, positioned on a helixed torque pin, the torque pin connected to the spider; wherein as the roller assembly wears, the at least one roller assembly tracks along a helixed path of the torque pin in a distal direction from the bearing assembly.

Embodiments also describe a drive pulley for a continuously variable transmission including a stationary sheave

2

with a stationary shaft; a movable sheave axially movable relative to the stationary sheave and in contact with the stationary shaft; a spider in contact with at least the moveable sheave and stationary shaft; a spring member, biasing the movable sheave axially away from the stationary sheave; at least one centrifugal actuator including an arm pivotally connected to one of the movable sheave and the spider, the arm pivoting away from the one of the movable sheave and the spider as a speed of rotation of the drive pulley increases, the arm pushing against another one of the movable sheave and the spider as the arm pivots away from the one of the movable sheave and the spider, thereby moving the movable sheave axially toward the stationary sheave, the at least one centrifugal actuator being disposed radially outward of the stationary sheave shaft; and a torque transfer assembly operatively connected to at least one of the spider and the movable sheave, the torque transfer assembly transferring torque between the spider and the movable sheave, the torque transfer assembly including, a torque bearing assembly and at least one slider block assembly, positioned on a helixed torque pin, the torque pin connected to the spider; wherein as the slider block assembly wears, the at least one slider block assembly tracks along a helixed path of the torque pin in a distal direction from the bearing assembly.

Embodiments further include a drive pulley for a continuously variable transmission including a stationary sheave, with a stationary shaft; a movable sheave axially movable relative to the stationary sheave and in contact with the stationary shaft;

a spider in contact with at least the moveable sheave and stationary shaft; a spring member, biasing the movable sheave axially away from the stationary sheave; at least one centrifugal actuator including an arm pivotally connected to one of the movable sheave and the spider, the arm pivoting away from the one of the movable sheave and the spider as a speed of rotation of the drive pulley increases, the arm pushing against another one of the movable sheave and the spider as the arm pivots away from the one of the movable sheave and the spider, thereby moving the movable sheave axially toward the stationary sheave, the at least one centrifugal actuator being disposed radially outward of the stationary sheave shaft; and a torque transfer assembly operatively connected to at least one of the spider and the movable sheave, the torque transfer assembly transferring torque between the spider and the movable sheave, the torque transfer assembly including, a button slider block assembly, positioned on a torque pin, the torque pin connected to the spider; wherein the button slider block assembly is removable.

BRIEF DESCRIPTION OF DRAWINGS

This written disclosure describes illustrative embodiments that are non-limiting and non-exhaustive. Reference is made to illustrative embodiments that are depicted in the figures, in which:

FIG. 1 illustrates a perspective view **100** of a snowmobile, according to some embodiments.

FIGS. 2A-B illustrate perspective views **200** of a snowmobile without a shroud and seat, according to some embodiments.

FIGS. 3A-D illustrate perspective views **300** of snowmobile engine and drive train components, according to some embodiments.

FIGS. 4A-J illustrate perspective and cross-sectional views of CVT spider with roller-roller torque transfer assembly in a wear configuration, according to some embodiments.

FIGS. 5A-J illustrate perspective and cross-sectional views of CVT spider with roller-roller torque transfer assembly in a no wear configuration, according to some embodiments.

FIGS. 6A-H illustrate perspective and cross-sectional views of CVT drive clutch with roller-roller torque transfer assembly in a no wear and full shift configuration, according to some embodiments.

FIGS. 7A-H illustrate perspective and cross-sectional views of CVT drive clutch with roller-roller torque transfer assembly in a wear and full shift configuration, according to some embodiments.

FIGS. 8A-I illustrate exploded, perspective and cross-sectional views of CVT drive clutch with roller-roller torque transfer assembly in a wear and no shift configuration, according to some embodiments.

FIGS. 9A-I illustrate exploded, perspective and cross-sectional views of CVT electric start drive clutch with roller-roller torque transfer assembly in a wear and no shift configuration, according to some embodiments.

FIGS. 10A-J illustrate exploded, perspective and cross-sectional views of CVT drive clutch with roller-roller torque transfer assembly in a no wear and no shift configuration, according to some embodiments.

FIG. 11 illustrates an exploded view of CVT electric start drive clutch with button torque transfer assembly in a full shift configuration with shift stop, according to some embodiments.

FIGS. 12A-I illustrate perspective and cross-sectional views of a cam arm, according to some embodiments.

FIGS. 13A-K illustrate exploded, perspective and cross-sectional views of CVT drive clutch with slider-roller torque transfer assembly in a wear and full shift configuration, according to some embodiments.

FIGS. 14A-J illustrate perspective and cross-sectional views of CVT drive clutch with slider-roller torque transfer assembly in a wear and no shift configuration, according to some embodiments.

FIGS. 15A-K illustrate perspective and cross-sectional views of CVT spider with roller-slider torque transfer assembly in a wear configuration, according to some embodiments.

FIGS. 16A-I illustrate exploded, perspective and cross-sectional views of CVT drive clutch calibrated for use in a two-stroke engine, according to some embodiments.

FIGS. 17A-J illustrate perspective and cross-sectional views of CVT spider with button block torque transfer assembly for use in a two-stroke engine, according to some embodiments.

FIGS. 18A-E illustrate exploded, perspective and cross-sectional views of an uncalibrated CVT drive clutch with button block torque transfer assembly for use in a two-stroke engine in a no shift, no shift stop configuration, according to some embodiments.

FIGS. 19A-D illustrate perspective and cross-sectional views of an uncalibrated CVT drive clutch with button block torque transfer assembly for use in a two-stroke engine in a full shift, no shift stop configuration, according to some embodiments.

FIGS. 20A-E illustrate exploded, perspective and cross-sectional views of an uncalibrated electric start CVT drive

clutch with button block torque transfer assembly for use in a two-stroke engine in a no shift configuration, according to some embodiments.

FIGS. 21A-F illustrate exploded, perspective and cross-sectional views of an uncalibrated CVT drive clutch with damper ring for use in a two-stroke engine in a full shift configuration, according to some embodiments.

FIGS. 22A-E illustrate perspective and cross-sectional views of an uncalibrated CVT drive clutch with damper ring for use in a two-stroke engine in a no shift configuration, according to some embodiments.

FIGS. 23A-I illustrate exploded, perspective and cross-sectional views of an ATV, side by side (SXS), snowbike, or motorcycle CVT drive clutch with windage plate for use in a two-stroke or four-stroke engine in a full shift, no shift stop, configuration, according to some embodiments.

FIGS. 24A-I illustrate exploded, perspective and cross-sectional views of an ATV, side by side (SXS), snowbike, or motorcycle CVT drive clutch with windage plate for use in a two-stroke or four-stroke engine in a no shift, no shift stop configuration, according to some embodiments.

FIG. 25 illustrates a perspective view of an ATV or motorcycle CVT spider with button block assembly for use in a four-stroke engine, according to some embodiments.

FIGS. 26A-I illustrate perspective and cross-sectional views of an ATV or motorcycle CVT spider with button block assembly for use in a four-stroke engine, according to some embodiments.

FIGS. 27A-E illustrate perspective and cross-sectional views of a CVT cover assembly, according to some embodiments.

FIGS. 28A-K illustrate perspective and cross-sectional views of a CVT moveable sheave assembly, according to some embodiments.

FIGS. 29A-B illustrate perspective and cross-sectional views of a CVT stationary sheave assembly, according to some embodiments.

FIGS. 30A-E illustrate perspective and cross-sectional views of a CVT spider hub according to some embodiments.

FIGS. 31A-G illustrate perspective and cross-sectional views of a CVT eccentric cam assembly, according to some embodiments.

FIGS. 32A-E illustrate perspective and cross-sectional views of a CVT eccentric cam slider block assembly, according to some embodiments.

FIGS. 33A-H illustrate perspective and cross-sectional views of a CVT torque pin, according to some embodiments.

FIGS. 34A-J illustrate perspective and cross-sectional views of a CVT torque pin with helix, according to some embodiments.

FIGS. 35A-G illustrate perspective and cross-sectional views of a CVT wear-sleeved bearing assembly, according to some embodiments.

FIGS. 36A-E illustrate perspective and cross-sectional views of a CVT button block assembly, according to some embodiments.

FIGS. 37A-E illustrate perspective and cross-sectional views of a CVT roller assembly, according to some embodiments.

FIGS. 38A-H illustrate perspective and cross-sectional views of a CVT button block assembly with dampers, according to some embodiments.

#### DETAILED DESCRIPTION

Conventional snowmobile powertrains incorporate a continuously variable transmission (CVT) having a drive pulley

that is operatively coupled to the engine crankshaft and a driven pulley coupled to a driven shaft. The drive pulley transfers torque to the driven pulley via a drive belt looped around both pulleys. Typically, the driven shaft is a transverse jackshaft which drives the input member of a chain and sprocket reduction drive. The output of the reduction drive is coupled to one end of an axle on which are located one or more drive track drive sprockets.

The drive pulley includes centrifugal actuators through which the drive ratio of the drive pulley is varied progressively as a function of the engine speed and load. The centrifugal actuators are connected to a movable sheave of the drive pulley. The drive pulley also includes a fixed sheave which is axially fixed. The fixed sheave and the movable sheave are rotatable together. The movable sheave is movable axially toward the fixed sheave by the action of the centrifugal actuators and away from the fixed sheave by a biasing spring. The centrifugal actuators generally include centrifugal weights in the form of adjusting arms. Each of the arms is connected to the movable sheave of the drive pulley by a pin, and pivots outwards about its corresponding pin. As they pivot, the arms are in contact with corresponding rollers disposed on a spider fixed relative to the fixed sheave. When the adjusting arms pivot outwards as a result of centrifugal force, they slide against their corresponding roller and the axially movable sheave is pushed towards the fixed sheave.

Due to manufacturing tolerances and the type of connection used, it is possible that the spider and movable sheave can rotate slightly relative to one another during acceleration and deceleration of the drive pulley. As a result, the adjusting arms move slightly in a direction generally parallel to an axis of rotation or their corresponding rollers. This is sometimes referred to as backlash. This slight movement causes rubbing of the adjustable arms against their respective rollers and can result in portions of the arms, the rollers or both to wear.

Embodiments of the present disclosure provide wear adjusting torque transfer devices, such as roller, slider, and button (solid or damped) block assemblies. In some embodiments, the wear adjusting feature is optional or removeable. In one embodiment, a spider in a primary drive clutch of a CVT system uses rollers to transfer torque. Two rollers can be utilized, one for primary forward torque and one for reverse and engine braking torque. In addition to reverse engine braking, the secondary roller (or button or slider, in other embodiments) can be engaged when slowing down. The secondary roller can become the primary forward torque roller during engine reverse operation. The primary torque roller can be on the centerline axis of its locating pin. The secondary torque roller can be located on an eccentric cam on the centerline axis of the locating pin. The eccentric cam has a one-way clutch to allow adjustment of slack from component wear, but not the return to a slack condition. To aide the wear adjustment, a method of providing rotatory force to the cam, such as with a torsional spring, can be utilized.

In another embodiment, a method for adjustment relies on a mass for the reverse torque roller. This mass would be a part of the eccentric cam feature. The centrifugal force acting on the mass would move the cam mass outward, and by having this cam in contact and guided by a helixed spline or helixed track, causes the cam to rotate as the mass moves outward radially to adjust for wear in the primary and secondary rollers.

By separating the torque transfer device and the cam actuation portion of the drive clutch to different locations

(such as a 60 degree offset), a roller to transfer torque can be utilized, as compared to a sliding button, in one embodiment. The torque transfer system can be utilized in a forward and reverse torque transfer roller system. The forward or primary torque transfer roller can be on the axial centerline of the locating/torque transfer pin. The reverse or secondary torque transfer roller can be located on an eccentric cam. This eccentric cam is free to rotate about the axial centerline of the torque transfer pin, but with the addition of a one-way bearing/clutch it can only rotate in one direction to take up the slack/wear of the rollers. The eccentric cam can be coaxially located on the torque transfer pin with a bushing. The eccentric cam can be aided in wear slack take-up by a member that provides torque to the cam, such as a torsion spring. The rollers can transfer torque between the spider (fixed to the post or stationary shaft of the drive clutch) and the moveable sheave. The moveable sheave travels axially up and down the stationary shaft post to change the ratio of the CVT system. The rollers can be cylindrical in the radial direction to the centerline of the clutch along the axis of the torque transfer pin. The spider design can allow for slight movement radially from the centerline of the drive clutch to ease in assembly, but not in a manner to take up the slack in the fit of the spider to moveable sheave.

Such example embodiments provide a quieter, narrower drive clutch, with fewer parts, allowing for narrower body shrouding on the vehicle. The CVT drive clutch can be reduced in width or thickness by 25-30 mm for example. The embodiments described herein also provide for easier servicing or replacement of worn parts, while maintaining performance and durability of the CVT system.

Referring to FIG. 1, a perspective view **100** of a snowmobile is shown, according to some embodiments. A chassis **104** or frame supports an engine (see FIG. 2A), drive or power train (see FIG. 2A), a drive track **106**, handlebars **102** and skis **112**. A shroud **110** or fairing in contact with the chassis covers and protects various components of the vehicle. A seat **108** is positioned rearward of the handlebars **102**. With the shroud **110** and seat **108** removed (see FIGS. 2A-B), the engine **202** is shown in contact with a drive train **204**. The drive train **204** includes a continuously variable transmission (CVT), for transferring power from the engine **202** to the drive track **106**.

Referring to FIGS. 3A-D, perspective views **300** of snowmobile engine and drive train **204** components are shown, according to some embodiments. An engine **202** converts chemical energy to mechanical energy via a rotating input shaft in contact with a transmission or drive train **204**, such as a CVT. The CVT includes a rotatable drive (or primary) clutch **302** connected to the input shaft. The CVT also includes a rotatable driven (or secondary) clutch **304** connected to an output shaft or jack shaft **314**, the driven clutch **302** having a laterally stationary sheave and a laterally movable sheave that is normally biased toward the stationary sheave. An endless flexible drive belt **306** is disposed about the drive **302** and driven clutches **304**. Typically, the CVT transmission is connected to the output shaft of the vehicle's engine, the transmission providing continuously variable gear reduction from the relatively higher rotation speed of the engine to the relatively lower rotation speed of the vehicle drive axle. A CVT may be used in conjunction with an additional gear box/transmission **312**, if desired. For example, it may be desirable to provide a gear box **312** to permit the driver to shift between forward and reverse gears. In such cases, a neutral position may also be provided, along with, e.g., an optional low gear for extra power at low speeds. Typically, such a gear box **312** is connected to the

jack shaft **314** of the CVT, the gear box **312** in turn having a drive shaft **308** connected by suitable linkages (sprockets **310**, for example) to the drive track **106**.

The endless, flexible, generally V-shaped drive belt **306** is disposed about the clutches **302**, **304**. Each of the clutches has a pair of complementary sheaves, one of the sheaves being laterally movable with respect to the other. The effective gear ratio of the transmission is determined by the positions of the movable sheaves in each of the clutches. The secondary driven clutch **304** has its sheaves normally biased together (e.g., by a compression spring working in combination with a helix-type cam, as described below), so that when the engine is at idle speeds the drive belt rides near the outer perimeter of the driven clutch sheaves.

The spacing of the sheaves in the primary drive clutch **302** usually is controlled by centrifugal flyweights (such as a cam arm). As the drive clutch **302** rotates faster (in response to increased engine rpm) the flyweights urge the movable sheave toward the stationary sheave. This pinches the drive belt **306**, causing the belt **306** to begin rotating with the drive clutch **302**, the belt in turn causing the driven clutch **304** to begin to rotate. Further movement of the drive clutch's **302** movable sheave toward the stationary sheave forces the belt **306** to climb outwardly on the drive clutch sheaves, increasing the effective diameter of the drive belt path around the drive clutch **302**. Thus, the spacing of the sheaves in the drive clutch **302** changes based on engine rpm. The clutch therefore can be said to be speed sensitive.

As the sheaves of the drive clutch **302** pinch the drive belt **306** and force the belt **306** to climb outwardly on the drive clutch sheaves, the belt **306** (not being stretchable) is pulled inwardly between the sheaves of the driven clutch **304**, decreasing the effective diameter of the drive belt path around the driven clutch **304**. This movement of the belt **306** inwardly and outwardly on the drive **302** and driven clutches **304** smoothly changes the effective gear ratio of the transmission in infinitely variable increments.

FIGS. 4A-J illustrate perspective and cross-sectional views of CVT snow spider with roller-roller torque transfer assembly in a wear configuration, according to some embodiments. Spider body **402** includes torque transfer device assemblies **412** and actuator assemblies **410**. Each torque transfer device assembly **412** and actuator assembly **410** are offset about 60 degrees from the adjacent assembly or about 120 degrees from an adjacent similar assembly. Actuator rollers **404** can be secured to the spider body **402** by a cam roller pin **406** and cam roller cap or fastener **408**. In this embodiment, the torque transfer device assembly **412** includes a torque bearing assembly **416**, an eccentric roller assembly **418** and torque pin **420**. The torque pin **420** fastens to the spider body **402** and can be further secured by securing pin **422** through securing pin aperture **426**. The torque pin **420** can be positioned in torque pin aperture **424**. A hub **427** can be secured to the spider body **402** with fasteners **428**, and an interference fit. The hub **427** includes a shaft aperture **431**, in line with aperture **430** for integration with a stationary sheave post or shaft (such as by threading). The optional interference fit can be facilitated by conical shaped points (i.e., the taper of the parts fit together like two cones stacking) of contact at the hub **427** and spider body **402**. Load can then be further transferred through the hub **427** and less through the fasteners **428**. The walls surrounding hub aperture **431**, walls surrounding spider aperture **430**, or both can be tapered. The walls of apertures, **431**, **430** can be tapered about 0.5% to 2%, or about 1% to about 1.5%, for example. A wear configuration describes a CVT configuration after substantial wear of the indicated parts. A no wear

configuration describes new or nearly new parts before any substantial wear has occurred. Wear can include about a 0.1% to about a 10% reduction by mass or surface area of a part. Wear can include 0.5% to about 5%, about 1% to about 7%, or about 2% to about 8% reduction in mass or surface area.

The spider body **402** can be manufactured of aluminum or be substantially manufactured of aluminum, for example. The hub **427** may be manufactured of steel to provide additional strength to the spider body **402** and reduce the overall width or thickness of the assembly. Optionally, the hub **427** can be integrated as part of the spider body **402**, if made of the same material. The aluminum spider body **402** and steel hub **427** can be secured together with fasteners **428**, but torque is transmitted through a combination of the fastener bolted joint, as well as the interference fit between the aluminum and steel components, such as with a press fit. The interference fit and bolt clamp load help transfer torque.

The unique shape of having the actuator assembly **410** 60 degrees offset to the torque transfer device **412** (slider or roller) allows for a more compact design and width of the drive clutch by tucking the torque transfer mechanism into the casting profile, and profiling the cam arm roller support structure of the actuator assembly **410** to the moveable sheave casting profile. Torque transfer device **412** is positioned further centrally than on traditional spiders and provides additional reduction in diameter and overall weight.

The eccentric roller assembly **418** separates from the torque bearing assembly **416** as the roller follows the helixed path of the torque pin **420** as wear occurs. The eccentric path provides alternating contact between the torque bearing assembly **416** and eccentric roller assembly **418**, extending the life of the system while allowing easier access for service and replacement. As the primary assembly **418** wears from travel up and down the tower or post, the secondary assembly **416** moves up the one-way helixed path, forcing a closer fit against a tower face in a forward moving configuration or against an opposite tower face in a reverse (or slowing down) configuration, or both. Line **432** of FIG. **41** shows the offset contact of the rollers with a tower or post. Rollers **404** can be easily removed and replaced as wear occurs by contact with a cam arm.

FIGS. 5A-J illustrate perspective and cross-sectional views of CVT snow spider with roller-roller torque transfer assembly in a no wear configuration, according to some embodiments. In the no wear configuration, the positioning of the torque bearing assembly **416** and eccentric roller assembly **418** are immediately adjacent, as the eccentric roller assembly **418** has not started climbing the helixed path of the torque pin **420**. Line **432** of FIG. **51** shows the offset, but with new or nearly new parts showing no substantial wear.

FIGS. 6A-H illustrate perspective and cross-sectional views of CVT drive clutch with roller-roller torque transfer assembly in a no wear and full shift configuration, according to some embodiments. In all fully shifted configurations, stationary sheave **600** and moveable sheave **602** are in close proximity or in contact near an axial line. As the drive clutch **302** shifts, the cam arms **608** push away from and on rollers **404**, moving the sheaves **600**, **602** together. The moveable sheave **602** rides along stationary post or shaft **604**. The spider **402** is in contact with a plurality of towers **610** of the moveable sheave **602**. The towers **610** are shorter and positioned further inward than traditional moveable sheaves **602**. The torque transfer device assembly **412** is in contact with the towers **610**, which can incur wear as the CVT is

engaged. The enhanced cross-sectional view in FIG. 6H shows the offset gap **614** between eccentric roller assembly **418** and tower **610**. FIGS. 7A-H illustrate perspective and cross-sectional views of CVT drive clutch with roller-roller torque transfer assembly in a wear and full shift configuration, according to some embodiments.

FIGS. 8A-I illustrate exploded, perspective and cross-sectional views of CVT drive clutch with roller-roller torque transfer assembly in a wear and no shift configuration, according to some embodiments. A stationary post or shaft **604** of a stationary sheave **600** can be in contact with one or more thrust washers **800**, idler bearing **802**, and collar **804** before assembly with moveable sheave **602**. The collar **804** can act as an extension of the stationary shaft, concentric to the idler bearing allowing the moveable sheave to transition from collar to idler bearing **802** as the sheave travels axially. The collar **804** can be optionally integrated into the shaft **604**. One of more of thrust washers **800** can be integrated with collar **804** or idler bearing **802**. Alternatively, spider body **402** or hub **427** can integrate collar **804** and one or more thrust washers **800** or spacers/washers **816,818**. In one embodiment, the hub can be machined to include spacers/washers **816, 818**. An inner belt rides on the bearing **802** prior to clutch engagement. This configuration also allows for more consistent belt tensions and lessens or eliminates the need for a user to manually adjust driven clutch sheave spacing, affecting belt deflection and drive ratio. The idler bearing **802** can be a two-way or multi-directional roller bearing positioned on an input shaft (either directly or indirectly) and in contact with an interior surface of the belt. The positioning of bearing **802** allows for the input shaft to rotate while in idle without engaging the belt. The belt can maintain tension, even in idle, and a user does not have to periodically monitor and manually adjust belt tension. Further, the belt can now engage the sheaves at a lower position (closer to the input shaft) and in a lower powerband, accessing higher torque, lower speed applications.

Because the belt **306** is maintained at a higher tension (i.e., tighter) in idle, the neutral gap (gap between two sheaves when at idle state without belt) is larger and the sheaves move less to engage the belt **306**. The belt gap (distance between the belt and each sheave) is also tighter, which contributes to more consistent belt **306** tension, better engagement out of idle and less movement needed by the sheaves to engage.

One or more cam arms **608** can be fastened to the moveable sheave with a cam arm pin **806** and cam arm pin fastener **808**. Further, a spider body **402** engages the post **604** and sheave **602** at towers **610** and with calibration shim **816** and neutral gap washer **818**. The calibration shim **816** affects the angle and range of cam arm **608** movement and pathing.

A cover **606** secures spring **612** (or other biasing member) while retaining ring **812** and optional shift stop **810** are installed onto the stationary shaft **604** prior to cover **606** and spring **612** installation. The spider **402** design allows for a greater recess to position spring **612**. The retaining ring **812** provides an additional safety measure of securing the spider **402** in case of it loosening over time. The retaining ring **812** can be a snap ring for example. The ring **812** fits inside the diameter of the spring **612** and replaces the use of a traditional jam nut. In one embodiment, the retaining ring **812** can be positioned within a groove or recess (not shown) of the spider body **402** or shaft **604**. Additionally, collar **804** can be positioned over the ring **812**. The ring **812** can prevent full separation from stationary shaft **604**. The shift stop **810** limits travel and prevents the sheaves **600, 602**

from touching, preventing wear. The shift stop **810** can create a gap between sheaves **600, 602** of 0.1 mm to about 3.5 mm, about 0.5 mm to about 2.5 mm, or about 1 mm to about 2 mm, for example. The shift stop **810** can be in contact with a sheave shoulder **605**, the shoulder configured in various thickness to speed or ratio requirements across different vehicle designs. Fasteners **814** secure the cover **606** to the spider body **402**. A no shift configuration, the spring **612** provides tension to keep sheaves **600** and **602** apart until shifting is engaged. In a wear configuration, gap **614** shows the space between eccentric roller **418** and tower **610** and gap **616** shows the distance traveled up the helix of the torque pin **420**.

FIGS. 9A-I illustrate exploded, perspective and cross-sectional views of CVT electric start drive clutch with roller-roller torque transfer assembly in a wear and no shift configuration, according to some embodiments. An electric start ring **900**, secured to the stationary sheave **600** by fasteners **902** is shown. FIGS. 10A-J illustrate exploded, perspective and cross-sectional views of CVT drive clutch with roller-roller torque transfer assembly in a no wear and no shift configuration, according to some embodiments. FIG. 11A illustrates an exploded view of CVT electric start drive clutch with button torque transfer assembly in a full shift configuration with shift stop, according to some embodiments. The torque transfer device assembly **412** includes a button block assembly **1102**.

Referring to FIGS. 12A-I, perspective and cross-sectional views of a cam arm **608** is shown, according to some embodiments. Cam arm **608** includes upper contact area **1202**, cam arm pin sleeve **1204**, and upper contact area lip **1206**. A traditional cam arm or flyweight **608** has a rectangular profile in a front view, such as in FIG. 12E. In this embodiment, the upper contact area **1202** that engages the spider body **402** to move the moveable sheave **602** has a T-shape, increasing surface area contacted. The lip **1206** can be symmetric to form a T-shape, or in one embodiment can be asymmetric or only present on one side to form an L-shape. The surface area of the upper contact area **1202** can be increased about 5%, about 10%, about 15%, about 20%, about 30%, or about 35% more over a rectangular (non-T shaped) profiled cam arm **608**. By increasing the surface area of the upper contact area **1202**, less stress is placed on the cam arm **608** over time and the overall weight of the cam arm **608** can be reduced.

By changing the shape and profile of the upper contact area **1202**, the center of mass of cam arm **608** can be changed. Cam arm **608** mass varies based on uncalibrated clutch positioning of the roller on the spider and the cam arm pin **806**. The mass also varies based on the shape of the upper contact area **1202**. The cam arm pin sleeve **1204** (e.g., bushing) receives cam arm pin **806** for securing to the moveable sheave **602**. Cam arm **608** can be manufactured of powdered metal (e.g., iron with binder), steel, composite materials, etc. The cam arm **608** material can be chosen based on cost, density, and durability.

In a T-shaped configuration, each lip **1206** can be about 5% of the total width of the upper contact area. The width of each lip can be about 10%, about 15%, or about 20% of the total width of the upper contact area **1202** width, for example.

FIGS. 13A-K illustrate exploded, perspective and cross-sectional views of CVT drive clutch with slider-roller torque transfer assembly in a wear and full shift configuration with shift stop, according to some embodiments. In this embodiment, the torque transfer device assembly **412** includes a slider block assembly **1300**. FIGS. 14A-J illustrate perspec-

tive and cross-sectional views of CVT drive clutch with slider-roller torque transfer assembly in a wear and no shift configuration with shift stop, according to some embodiments. FIGS. 15A-J illustrate perspective and cross-sectional views of CVT spider with roller-slider torque transfer assembly in a wear configuration, according to some 5 embodiments. The slider block assembly 1300 includes eccentric slider block 1302 and eccentric slider cam 1304. Unlike a roller, the slider block assembly 1300 slides up and down the tower 610 as opposed to rolling. Using the helixed path of torque pin 420, the torque transfer device 412 can reduce wear and extend the life of the assembly. FIGS. 16A-I illustrate exploded, perspective and cross-sectional views of CVT drive clutch calibrated with button block assembly for use in a two-stroke engine, according to some 10 embodiments. A calibrated system fully includes cam arms 608 and spring 612. Calibration can also refer to the position of the spider body 402 in relation to the moveable sheave 602.

FIGS. 17A-J illustrate perspective and cross-sectional views of CVT spider with button block assembly for use in a two-stroke engine, according to some embodiments. The torque transfer device assembly 412 includes button block assembly 1102. The assembly 1102 includes button block body 1702 and securing pin 1704 through securing pin 25 apertures 1706. Securing pin 1704 can provide orientation of the button block body 1702 by securing pin apertures 1706 relative to the spider 412. The spider 412 can be equipped with or without securing pin 1704 depending on the application.

FIGS. 18A-E illustrate exploded, perspective and cross-sectional views of an uncalibrated CVT drive clutch with button block torque transfer assembly for use in a two-stroke engine in a no shift, no shift stop configuration, according to some embodiments. FIGS. 19A-D illustrate perspective and cross-sectional views of an uncalibrated CVT drive clutch with button block torque transfer assembly for use in a two-stroke engine in a full shift, no shift stop configuration, according to some embodiments. FIGS. 20A-E illustrate 35 exploded, perspective and cross-sectional views of an uncalibrated electric start CVT drive clutch with button block torque transfer assembly for use in a two-stroke engine in a no shift configuration, according to some embodiments.

FIGS. 21A-F illustrate exploded, perspective and cross-sectional views of an uncalibrated CVT drive clutch with damper ring for use in a two-stroke engine in a full shift configuration with shift stop, according to some embodiments. A damper ring 2100 can be secured to sheave 602 with fasteners 2102. The damper ring 2100 can provide additional inertia to the engine, especially in cases where an electric start is absent. FIGS. 22A-E illustrate perspective and cross-sectional views of an uncalibrated CVT drive clutch with damper ring for use in a two-stroke engine in a no shift configuration with shift stop, according to some 50 embodiments. FIGS. 23A-I illustrate exploded, perspective and cross-sectional views of an ATV, side by side (SXS), snowbike, or motorcycle CVT drive clutch with damped button block torque transfer assembly and windage plate for use in a two-stroke or four-stroke engine in a full shift configuration, according to some embodiments. Additionally, a fan 2300 can be integrated with stationary sheave 600 for dirt applications. Dirt, or non-snow, applications tend to operate in higher ambient temperature environments and the CVT is often encased in an enclosed shroud (i.e., box) to protect from debris. These factors lead increased air flow considerations. FIGS. 24A-I illustrate exploded, perspective 65

and cross-sectional views of an ATV, side by side (SXS), snowbike, or motorcycle CVT drive clutch with damped button block torque transfer assembly and windage plate for use in a two-stroke or four-stroke engine in a no shift, no shift stop configuration, according to some embodiments.

FIGS. 25 and 26A-I illustrate perspective and cross-sectional views of an ATV or motorcycle CVT spider with button block assembly for use in a two- or four-stroke engine, according to some embodiments. Hub 2500 includes additional thickness and structural features as an option for a four-stroke engine application that can function as neutral gap and calibration shims as previously seen.

FIGS. 27A-E illustrate perspective and cross-sectional views of a CVT cover assembly, according to some embodiments. Cover 606 can be secured to moveable sheave 602 with fasteners and stationary post 604 with bearing 2700, for example. Cover 606 supports towers 610 and further secures the towers 610 from moving or flexing outward. FIGS. 28A-K illustrate perspective and cross-sectional views of a CVT moveable sheave assembly, according to some 20 embodiments. Moveable sheave 602 can be secured using bearing 2802 and retaining ring 2804, for example. Structural ribbing 2800 or features can be included to provide additional strength to the moveable sheave 602 and drive clutch 302 assembly. The ribbing 2800 can reduce movement or stress on the towers and allows for placement of towers 610 on the moveable sheave 602, as opposed to positioning on the spider body 402. The structural ribbing 2800 can be fabricated or attached between towers 610 and an inner surface of the sheave or between features in contact with the inner surface of the sheaves. The ribbing 2800 can include 2 or more, 5 or more, 20 or more, or 30 or more features. The surface area covered by the ribbing 2800 on an inner surface of the sheave 602 can include 3% or more, 10% or more, 40% or more or 70% or more of the total surface area. The ribbing 2800 further secures the towers 610 from deflection and wear. The ribbing 2800 can include major and minor ribbing features.

FIGS. 29A-B illustrate perspective and cross-sectional views of a CVT stationary sheave assembly, according to some embodiments. The sheave 600 can be in contact with a crankshaft from an engine. Four-stroke engines in recreational vehicles often utilize 30 mm taper. In a two-stroke application and four-stroke dirt bike/ATV application, the crankshaft taper is often 33 mm FIGS. 30A-E illustrate perspective and cross-sectional views of a CVT hub, according to some embodiments. As discussed above, the hub 427 can include a taper or conical shape to interface with corresponding spider body 402.

FIGS. 31A-G illustrate perspective and cross-sectional views of a CVT eccentric cam assembly, according to some embodiments. An eccentric roller assembly 418 can include roller insert or bearing 3100, pathing features 3104 or one-way clutch, and eccentric roller 3102. The insert 3100 can be optionally integrated into the roller 3102. The pathing 3104 mates or contacts with helix on torque pin 420 to create an eccentric path up the pin 420 as wear occurs.

FIGS. 32A-E illustrate perspective and cross-sectional views of a CVT eccentric cam slider block assembly, according to some embodiments. An eccentric slider block assembly 1300 can include bearing 3200, eccentric slider cam 1304, retaining ring (or thrust washer) 3202, and slider block 1302.

FIGS. 33A-H illustrate perspective and cross-sectional views of a CVT torque pin, according to some embodiments. In some embodiments, a torque pin 420 can include aperture 1706 for receiving a first securing pin and U-channel 3300

for receiving a second securing pin. The U-channel securing mechanism provides additional safety by preventing the torque pin **420** from dislodging during use, in addition to providing additional alignment. FIGS. **34A-J** illustrate perspective and cross-sectional views of a CVT torque pin with helix, according to some embodiments. A helix or helixed section **3400** can be utilized to guide an eccentric cam roller or slider, for example.

FIGS. **35A-G** illustrate perspective and cross-sectional views of a CVT wear-sleeved bearing assembly, according to some embodiments. A wear-sleeved bearing assembly **416** can include bearing outer shell **3500** and bearing **3502**. In addition to a roller bearing, the bearing **3502** can include needle bearing, plastic or metallic bushing, for example.

FIGS. **36A-E** illustrate perspective and cross-sectional views of a CVT button block assembly, according to some embodiments. A button block assembly **1102** can include body **1702**, securing pin aperture **1706** and buttons **3604**. The body **1702** can be manufactured of aluminum, for example. The buttons **3604** can be made of engineered plastic, such as VESPEL that provides durability and low friction. A torque pin aperture **3608** runs transversely to aperture **1706** for securing the torque pin **420**.

FIGS. **37A-E** illustrate perspective and cross-sectional views of a CVT roller assembly, according to some embodiments. The roller assembly **404** can include flanged or cylindrical bearing caps **3704**.

FIGS. **38A-H** illustrate perspective and cross-sectional views of a CVT button block assembly with dampers, according to some embodiments. In some embodiments, the button block assembly **1102** further includes dampers **3800**. In some applications the dampers **3800** can be utilized to reduce vibrational noise from an output shaft. The dampers **3800** can be positioned within caps **3604**, such as by pressing. The dampers **3800** can be replaced and can be manufactured of an engineered plastic. The material can also include a controlled dampening coefficient.

Other embodiments of the present disclosure are possible. Although the description above contains much specificity, these should not be construed as limiting the scope of the disclosure, but as merely providing illustrations of some of the presently preferred embodiments of this disclosure. It is also contemplated that various combinations or sub-combinations of the specific features and aspects of the embodiments may be made and still fall within the scope of this disclosure. It should be understood that various features and aspects of the disclosed embodiments can be combined with or substituted for one another in order to form various embodiments. Thus, it is intended that the scope of at least some of the present disclosure should not be limited by the particular disclosed embodiments described above.

Thus the scope of this disclosure should be determined by the appended claims and their legal equivalents. Therefore, it will be appreciated that the scope of the present disclosure fully encompasses other embodiments which may become obvious to those skilled in the art, and that the scope of the present disclosure is accordingly to be limited by nothing other than the appended claims, in which reference to an element in the singular is not intended to mean "one and only one" unless explicitly so stated, but rather "one or more." All structural, chemical, and functional equivalents to the elements of the above-described preferred embodiment that are known to those of ordinary skill in the art are expressly incorporated herein by reference and are intended to be encompassed by the present claims. Moreover, it is not necessary for a device or method to address each and every problem sought to be solved by the present disclosure, for it

to be encompassed by the present claims. Furthermore, no element, component, or method step in the present disclosure is intended to be dedicated to the public regardless of whether the element, component, or method step is explicitly recited in the claims.

The foregoing description of various preferred embodiments of the disclosure have been presented for purposes of illustration and description. It is not intended to be exhaustive or to limit the disclosure to the precise embodiments, and obviously many modifications and variations are possible in light of the above teaching. The example embodiments, as described above, were chosen and described in order to best explain the principles of the disclosure and its practical application to thereby enable others skilled in the art to best utilize the disclosure in various embodiments and with various modifications as are suited to the particular use contemplated. It is intended that the scope of the disclosure be defined by the claims appended hereto

Various examples have been described. These and other examples are within the scope of the following claims.

What is claimed is:

1. A drive pulley for a continuously variable transmission comprising:

a stationary sheave, including a stationary shaft;  
a movable sheave axially movable relative to the stationary sheave and in contact with the stationary shaft;  
a spider in contact with at least the moveable sheave and stationary shaft;

a spring member, biasing the movable sheave axially away from the stationary sheave;

at least one centrifugal actuator including an arm pivotally connected to one of the movable sheave and the spider, the arm pivoting away from the one of the movable sheave and the spider as a speed of rotation of the drive pulley increases, the arm pushing against another one of the movable sheave and the spider as the arm pivots away from the one of the movable sheave and the spider, thereby moving the movable sheave axially toward the stationary sheave, the at least one centrifugal actuator being disposed radially outward of the stationary sheave shaft; and

a torque transfer assembly operatively connected to at least one of the spider and the movable sheave, the torque transfer assembly transferring torque between the spider and the movable sheave, the torque transfer assembly including,

a button slider block assembly, positioned on a torque pin, the torque pin connected to the spider, wherein the torque pin defines a longitudinal axis pointing at the stationary shaft;

wherein the button slider block assembly is removeable.

2. The drive pulley of claim 1, wherein the at least one centrifugal actuator is positioned about 60 degrees offset from at least one torque transfer assembly.

3. The drive pulley of claim 1, wherein the button slider block assembly comprises a button block body and two buttons.

4. The drive pulley of claim 3, wherein the two buttons are made of engineered plastic and are replaceable.

5. The drive pulley of claim 3, further comprising one or more dampers.

6. The drive pulley of claim 5, wherein the one or more dampers are manufactured of a material including a controlled dampening coefficient.

7. The drive pulley of claim 5, wherein the one or more dampers are replaceable.

8. The drive pulley of claim 3, wherein the button block body includes a torque pin aperture along the longitudinal axis defined by the torque pin, the button block body configured to receive the torque pin therein.

9. The drive pulley of claim 8, wherein the button body includes a second aperture running transverse to the torque pin aperture, the second aperture configured to receive a securing pin.

10. The drive pulley of claim 1, wherein the torque pin includes a U-channel configured to receive a securing pin.

11. The drive pulley of claim 1, wherein the torque pin includes a securing pin aperture configured to receive a securing pin.

12. The drive pulley of claim 1, wherein the torque pin is removable from the spider.

\* \* \* \* \*