



(12) **DEMANDE DE BREVET CANADIEN
CANADIAN PATENT APPLICATION**

(13) **A1**

(86) Date de dépôt PCT/PCT Filing Date: 2018/08/20
(87) Date publication PCT/PCT Publication Date: 2019/02/28
(85) Entrée phase nationale/National Entry: 2020/02/06
(86) N° demande PCT/PCT Application No.: GB 2018/052354
(87) N° publication PCT/PCT Publication No.: 2019/038525
(30) Priorité/Priority: 2017/08/21 (GB1713375.2)

(51) Cl.Int./Int.Cl. *E21B 23/06* (2006.01),
E21B 17/00 (2006.01), *E21B 33/12* (2006.01),
E21B 33/124 (2006.01), *E21B 33/127* (2006.01),
E21B 33/128 (2006.01), *F16J 15/08* (2006.01)
(71) Demandeur/Applicant:
MORHPACKERS LIMITED, GB
(72) Inventeur/Inventor:
RADTKE, CAMERON HILL, GB
(74) Agent: RIDOUT & MAYBEE LLP

(54) Titre : BARRIERE D'ISOLATION AMELIOREE
(54) Title: IMPROVED ISOLATION BARRIER

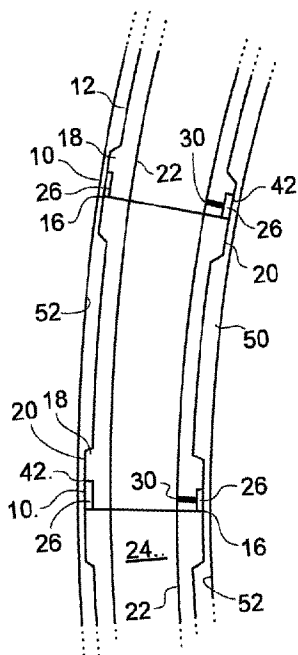

Fig. 3

(57) **Abrégé/Abstract:**

A method and apparatus for well intervention in which an expandable element is provided on a tubular. Using reclaimed drill pipe (12), a recess (26) is formed at an open end of the box section (16) and an annular sleeve (34) is slid over the pipe end into the recess (26). The sleeve (34) is affixed at either end by welding or suitable adhesive to provide a pressure tight chamber. A port (30) drilled through the pipe to access the chamber from the pipe bore is used to expand the sleeve (34) when the drill pipe is run in at tight tolerance in a wellbore.

(12) INTERNATIONAL APPLICATION PUBLISHED UNDER THE PATENT COOPERATION TREATY (PCT)

(19) World Intellectual Property
Organization
International Bureau



(10) International Publication Number
WO 2019/038525 A1

(43) International Publication Date
28 February 2019 (28.02.2019)

(51) International Patent Classification:

E21B 23/06 (2006.01) *E21B 33/128* (2006.01)
E21B 33/12 (2006.01) *E21B 17/00* (2006.01)
E21B 33/124 (2006.01) *F16J 15/08* (2006.01)
E21B 33/127 (2006.01)

(21) International Application Number:

PCT/GB2018/052354

(22) International Filing Date:

20 August 2018 (20.08.2018)

(25) Filing Language:

English

(26) Publication Language:

English

(30) Priority Data:

1713375.2 21 August 2017 (21.08.2017) GB

(71) Applicant: MORHPACKERS LIMITED [GB/GB];
Silvertrees Drive, Westhill, Aberdeen AB32 6BH (GB).

(72) Inventor: **RADTKE, Cameron Hill**; c/o MorphPackers Limited, Silvertrees Drive, Westhill, Aberdeen AB32 6BH (GB).

(74) Agent: **IPENTUS LIMITED**; The Old Manse, Wilsontown, By Forth, Lanark Strathclyde ML11 8EP (GB).

(81) Designated States (*unless otherwise indicated, for every kind of national protection available*): AE, AG, AL, AM, AO, AT, AU, AZ, BA, BB, BG, BH, BN, BR, BW, BY, BZ, CA, CH, CL, CN, CO, CR, CU, CZ, DE, DJ, DK, DM, DO, DZ, EC, EE, EG, ES, FI, GB, GD, GE, GH, GM, GT, HN, HR, HU, ID, IL, IN, IR, IS, JO, JP, KE, KG, KH, KN, KP, KR, KW, KZ, LA, LC, LK, LR, LS, LU, LY, MA, MD, ME, MG, MK, MN, MW, MX, MY, MZ, NA, NG, NI, NO, NZ, OM, PA, PE, PG, PH, PL, PT, QA, RO, RS, RU, RW, SA, SC, SD, SE, SG, SK, SL, SM, ST, SV, SY, TH, TJ, TM, TN, TR, TT, TZ, UA, UG, US, UZ, VC, VN, ZA, ZM, ZW.

(84) Designated States (*unless otherwise indicated, for every kind of regional protection available*): ARIPO (BW, GH, GM, KE, LR, LS, MW, MZ, NA, RW, SD, SL, ST, SZ, TZ,

(54) Title: IMPROVED ISOLATION BARRIER

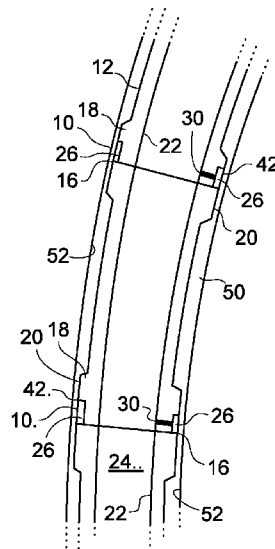

Fig. 3

(57) Abstract: A method and apparatus for well intervention in which an expandable element is provided on a tubular. Using reclaimed drill pipe (12), a recess (26) is formed at an open end of the box section (16) and an annular sleeve (34) is slid over the pipe end into the recess (26). The sleeve (34) is affixed at either end by welding or suitable adhesive to provide a pressure tight chamber. A port (30) drilled through the pipe to access the chamber from the pipe bore is used to expand the sleeve (34) when the drill pipe is run in at tight tolerance in a wellbore.

[Continued on next page]



WO 2019/038525 A1

WO 2019/038525 A1 

UG, ZM, ZW), Eurasian (AM, AZ, BY, KG, KZ, RU, TJ, TM), European (AL, AT, BE, BG, CH, CY, CZ, DE, DK, EE, ES, FI, FR, GB, GR, HR, HU, IE, IS, IT, LT, LU, LV, MC, MK, MT, NL, NO, PL, PT, RO, RS, SE, SI, SK, SM, TR), OAPI (BF, BJ, CF, CG, CI, CM, GA, GN, GQ, GW, KM, ML, MR, NE, SN, TD, TG).

Published:

— *with international search report (Art. 21(3))*

IMPROVED ISOLATION BARRIER

The present invention relates to an apparatus and method for
5 creating an isolation barrier in a well. In particular, though not
exclusively, the invention relates to drill pipe having an expandable
sleeve which is morphed to secure it to a well bore wall and create a
seal between the sleeve and well bore wall to form an isolation
barrier.

10

In the exploration and production of oil and gas wells, packers are
typically used to isolate one section of a downhole annulus from
another section of the downhole annulus. The annulus may be
between tubular members, such as a liner, mandrel, production
15 tubing and casing or between a tubular member, typically casing,
and the wall of an open borehole. These packers are carried into the
well on tubing and at the desired location, elastomeric seals are
urged radially outwards or elastomeric bladders are inflated to cross
the annulus and create a seal with the outer generally cylindrical
20 structure i.e. another tubular member or the borehole wall. These
elastomers have disadvantages, particularly when chemical injection
techniques are used.

As a result, metal seals have been developed, where a tubular
25 metal member is run in the well and at the desired location, an
expander tool is run through the member. The expander tool
typically has a forward cone with a body whose diameter is sized to
the generally cylindrical structure so that the metal member is
expanded to contact and seal against the cylindrical structure.
30 These so-called expanded sleeves have an internal surface which,
when expanded, is cylindrical and matches the profile of the
expander tool. These sleeves work well in creating an annular seal

between tubular members but can have problems in sealing against the irregular surface of an open borehole.

The present applicants have developed a technology where a metal sleeve is forced radially outwardly by the use of fluid pressure acting directly on the sleeve. Sufficient hydraulic fluid pressure is applied to move the sleeve radially outwards and cause the sleeve to morph itself onto the generally cylindrical structure. The sleeve undergoes plastic deformation and, if morphed to a generally cylindrical metal structure, the metal structure will undergo elastic deformation to expand by a small percentage as contact is made. When the pressure is released the metal structure returns to its original dimensions and will create a seal against the plastically deformed sleeve. During the morphing process, both the inner and outer surfaces of the sleeve will take up the shape of the surface of the wall of the cylindrical structure. This morphed isolation barrier is therefore ideally suited for creating a seal against an irregular borehole wall.

Such a morphed isolation barrier is disclosed in US 7,306,033, which is incorporated herein by reference. An application of the morphed isolation barrier for FRAC operations is disclosed in US2012/0125619, which is incorporated herein by reference. Typically, the sleeve is mounted around a supporting tubular body, being sealed at each end of the sleeve to create a chamber between the inner surface of the sleeve and the outer surface of the body. A port is arranged through the body so that fluid can be pumped into the chamber from the throughbore of the body.

Such morphed isolation barriers are expensive to manufacture as the supporting tubular body must handle the pressure required for sleeve expansion.

Additionally, to mount the sleeve upon the supporting tubular body requires a complicated arrangement of fittings. An arrangement is disclosed in US2012/0125619 in which an end nut is secured to the tubular body by suitable means. There is then provided a seal section housing which is screwed fast to the end nut and which surrounds a suitable arrangement of seals. The inner most ends of the respective seal section housings are secured to the respective ends of the sleeve by welding. A weld shroud is then provided coaxially about the outer surface of the weld, the respective end of the sleeve and the inner most end of the sealed section housing. The weld shroud is secured to the inner most end of the sealed section housing via a suitable screw threaded connection by welding. This arrangement is expensive and takes considerable time to assemble.

Yet further, the sleeve and fittings provide an assembly with a large outer diameter for running inside existing casing. This is a particular problem in well intervention such as in re-fracing where a tubular string of isolation barriers i.e. expandable packers are required to be set within the previously installed casing.

It is therefore an object of the present invention to provide a method of well intervention which obviates or mitigates at least some of the disadvantages of the prior art.

It is a further object of the present invention to provide well intervention apparatus for securing a tubular in a wellbore to facilitate isolation of a wellbore which obviates or mitigates at least some of the disadvantages of the prior art.

According to a first aspect of the invention there is provided a method of well intervention, in which a work string is run into a well, comprising the steps:

forming a work string from a plurality of sections of drill pipe;

5 at least one section of drill pipe including an expandable element located thereon;

running the work string into the well and expanding the expandable element to contact a wall of the well.

10 In this way, the method utilises an existing tubular from a wellbore. By using reclaimed drill pipe in the process of manufacturing an expandable packer, material costs and manufacturing material waste can each be minimised.

15 Preferably, the method comprises the steps of:

providing a section of drill pipe having an annular wall with an outer tubular surface and an inner tubular surface defining a bore;

forming a circumferential recess in the outer tubular surface of at least one longitudinal segment of the drill pipe, the recess

20 having at least an outer recess surface;

forming a perforation between the inner tubular surface and the outer recess surface;

25 providing an annular sleeve having a first sleeve end, a second sleeve end, an inner sleeve surface and an outer sleeve surface, wherein the sleeve conforms with the recess; and

30 providing airtight seals securing the annular sleeve to the drill pipe at the first sleeve end and the second sleeve end thus forming a cavity between the inner sleeve surface and outer recess surface wherein the cavity is accessible from the bore of the drill pipe through the perforation to provide the expandable element.

In the manufacture process, by forming a recess on a the drill pipe, providing an annular sleeve which conforms to the recess and securing the annular sleeve at each end by circumferential airtight seals, the perforation formed between the tubular bore and recess
5 provides an inlet to the cavity formed by the annular sleeve thus enabling the arrangement to be used as an expandable packer. The conformance of the sleeve to the recess enables the arrangement to be inserted in to environments where close tolerances are required whilst allowing for maximisation of the bore diameter.

10

Preferably, the method involves the step of forming the recess at an open end of the drill pipe. By forming the recess at an open end of a drill pipe, the annular sleeve may be provided as a single annular unit. Preferably the recess is formed at a box section of the drill
15 pipe. In this way, material removed for the recess is taken from the widest part of the drill pipe and the sleeve is therefore at the location of greatest diameter.

20

Alternatively, the method involves the steps of forming the recess in a centrally positioned longitudinal portion of the drill pipe, providing the annular sleeve as a first sleeve segment and a second sleeve segment which conform longitudinally to form an annular sleeve, arranging the first and second sleeve segment to conform around the tubular recess and securing the first and second sleeve
25 segments longitudinally to create an annular sleeve which conforms with the annular recess. By forming the recess in a position along the longitudinal body of the tubular, the well intervention apparatus may be arranged at any desired point along the tubular.

30

Preferably the steps of securing the annular sleeve involve creating welded joints. Use of welded joints in securing the annular sleeve to the drill pipe, and in the arrangement wherein the annular sleeve

is provided as two segments, enables strong, resilient airtight joints to be created.

Alternatively, the steps of securing the annular sleeve involve application of a suitable adhesive material. Use of a suitable adhesive material in creating the joints provides for airtight, lightweight joints to be created. Conveniently, the application of an adhesive material involves the step of shrink fitting the annular sleeve to the drill pipe.

10

Conveniently, multiple expandable elements may be formed along a length of drill pipe. Alternatively, multiple expandable elements may be formed along a work string, there being an expandable element at each box section of drill pipe.

15

According to a second aspect of the invention there is provided well intervention apparatus comprising:

a section of tubular having an annular wall with an outer tubular surface, an inner tubular surface defining a bore, and a circumferential recess formed in the outer tubular surface of at least one longitudinal segment of the tubular, the recess having an outer recess surface and a perforation between the inner tubular surface and the outer recess surface; and

an annular sleeve having a first sleeve end, a second sleeve end, an inner sleeve surface and an outer sleeve surface, wherein the sleeve conforms with the recess and is secured to the tubular at the first sleeve end and the second sleeve end such that a cavity is defined between the inner sleeve surface and outer recess surface which is accessible from the bore via the perforation to provide an expandable element.

Preferably the tubular is drill pipe. More preferably the tubular is reclaimed drill pipe.

5 The provision of a recess, on an outer surface of a drill pipe, which can receive an annular sleeve enables the drill pipe to be provided with a low profile sleeve arrangement. By securing the annular sleeve at each end by circumferential airtight seals, the perforation formed between the bore and recess provides an inlet to the cavity formed by the annular sleeve thus enabling the arrangement to be
10 used as an expandable packer. The conformance of the sleeve to the recess enables the arrangement to be inserted in to environments where close tolerances are required whilst allowing for maximisation of the bore.

15 In this way, by using pre-used or recycled drill pipe retrieved from a wellbore, the material costs and manufacturing material waste associated with the apparatus may each be minimised. Drill pipe is readily available and can be reclaimed easily.

20 Preferably the annular sleeve is secured to the drill pipe by welded joints. Use of welded joints in securing the annular sleeve to the drill pipe enables strong, resilient airtight joints to be created.

25 Alternatively, the annular sleeve is secured to the drill pipe by a suitable adhesive material. Use of a suitable adhesive material in creating the joints provides for airtight, lightweight joints to be created. Conveniently, the application of an adhesive material involves the step of shrink fitting the annular sleeve and adhesive material arrangement to the drill pipe.

30

Preferably, the recess is formed at an open end of the drill pipe. By forming the recess at an open end of the drill pipe, the annular

sleeve may preferably be provided as a single annular unit. The open end of a drill pipe may be a part of a box or pin joint of the drill string.

- 5 Alternatively, the recess is formed at a centrally positioned longitudinal portion of the drill pipe. By forming the recess in a central portion of the drill pipe, it is possible to provide expandable packer elements at any desired point along the drill pipe.
- 10 Conveniently, the annular sleeve is provided as first sleeve segment and a second sleeve segment which are operable to be secured together longitudinally to form an annular sleeve. By joining the two sleeve segments longitudinally, it is possibly to bring the two segments together and form them around a drill pipe
- 15 circumferentially then connect the segments to form a sleeve. This arrangement is particularly useful if it is not possible to slide a sleeve from an end of the drill pipe to a recess formed more centrally on a drill pipe.
- 20 Preferably the first sleeve segment and second sleeve segment are welded together.

Alternatively, the first sleeve segment and second sleeve segment are secured together by a suitable adhesive material.

25

- In the description that follows, the drawings are not necessarily to scale. Certain features of the invention may be shown exaggerated in scale or in somewhat schematic form, and some details of conventional elements may not be shown in the interest of clarity
- 30 and conciseness. It is to be fully recognized that the different teachings of the embodiments discussed below may be employed

separately or in any suitable combination to produce the desired results.

Accordingly, the drawings and descriptions are to be regarded as
5 illustrative in nature, and not as restrictive. Furthermore, the terminology and phraseology used herein is solely used for descriptive purposes and should not be construed as limiting in scope. Language such as "including," "comprising," "having," "containing," or "involving," and variations thereof, is intended to be
10 broad and encompass the subject matter listed thereafter, equivalents, and additional subject matter not recited, and is not intended to exclude other additives, components, integers or steps. Likewise, the term "comprising" is considered synonymous with the terms "including" or "containing" for applicable legal purposes.

15

All numerical values in this disclosure are understood as being modified by "about". All singular forms of elements, or any other components described herein including (without limitations) components of the apparatus are understood to include plural forms
20 thereof.

Embodiment of the present invention will now be described with reference to the following figures, by way of example only, in which:

25 Figure 1 shows a schematic illustration of method of well intervention using well intervention apparatus according to an embodiment of the present invention;

Figure 2A shows a portion of a well intervention apparatus during a step of a process of manufacturing in accordance with an
30 embodiment of the present invention;

Figure 2B shows a portion of a well intervention apparatus during a step of a process of manufacturing in accordance with an embodiment of the present invention;

5 Figure 2C shows a portion of a well intervention apparatus during a step of a process of manufacturing in accordance with an embodiment of the present invention;

Figure 2D shows a well intervention apparatus during a step of a process of manufacturing in accordance with an embodiment of the present invention;

10 Figure 3 shows a tubular provided with well intervention apparatus in accordance with another embodiment of the present invention;

Figure 4A shows a portion of a well intervention apparatus during a step of a process of manufacturing in accordance with an embodiment of the present invention;

15 Figure 4B shows a portion of a well intervention apparatus during a step of a process of manufacturing in accordance with an embodiment of the present invention;

Figure 4C shows a cross section of an annular sleeve component of a well intervention apparatus in accordance with an embodiment of
20 the present invention, and

Figure 4D shows a well intervention apparatus in accordance with an embodiment of the present invention.

Referring initially to Figure 1 of the drawings there is illustrated a
25 well, generally indicated by reference numeral 60, in which well intervention apparatus 10, formed from sections of drill pipe 12, is run as a work string 62 into casing 104 present wellbore 50, according to an embodiment of the present invention. Expandable elements in the form of annular sleeves 34 are located upon the
30 drill pipe 12 to provide a series of isolation barriers i.e. expandable packers within the casing 64. The well 10 has been drilled and

completed. The intervention may be to re-frac the well as is known in the art.

5 With reference to Figures 2A, 2B, 2C and 2D there is shown the development of a well intervention apparatus 10 during steps in the manufacture process. The apparatus 10 is formed from a section of drill pipe 12. Drill pipe 12 is as known in the art and commonly found and utilised for the drilling and completion of wells. It is recognised by its specially threaded ends on each section of drill
10 pipe.

In Figure 2A, there is shown a first end 14, of drill pipe 12, the first end 14 being an open end terminating in a box section 16 of a conventional box and pin joint coupling as is known in the art. In
15 this case the drill pipe 12 is pre-used drill pipe. The drill pipe 12 has an annular wall 18 defined by an outer tubular surface 20 and an inner tubular surface 22 which define a bore 24 through the drill pipe 12.

20 As is shown in Figure 2B, the manufacturing process subsequently involves a recess 26 being milled, or machined, into the annular wall 18 from outer tubular surface 20 at the first end 14. The recess 26 is formed circumferentially around the tubular end 14 and is defined by outer recess surface 28 and end recess surface 29.

25 With reference to Figure 2C, the method of manufacture subsequently involves the forming of a perforation 30 between the inner tubular surface 22 and the outer recess surface 28. The perforation 30 is, in this case, formed by drilling a hole using drill
30 unit 32.

In Figure 2D, one piece metal annular sleeve 34 is slipped over the end of the pipe 12 and onto the recess 26 formed at open end 14 of tubular. The annular sleeve 34 has a first sleeve end 36 which abuts against end recess surface 29, a second sleeve end 38 which terminates at the end face of open end 14 such that box joint 16 projects longitudinally therefrom. The annular sleeve 34 is further provided with inner sleeve surface 40 which lies adjacent outer recess surface 28, and outer sleeve surface 42 which has a surface level corresponding with outer tubular surface 20.

10

The manufacturing process further involves providing airtight seals 44, 46 which secure the annular sleeve 34 to the drill pipe 12 such that cavity 48 is defined between the inner sleeve surface 40 and outer recess surface 28. Seal 44 is formed by joining the first sleeve end 36 to end recess surface 29, in this case seal 44 is a welded joint. Seal 46 is formed by joining the second sleeve end 38 to the outer recess surface 28 at open end 14 of drill pipe 12; in this case seal 46 is also a welded joint. The cavity 48 is accessible from the bore 24 through hole 30. It will be appreciated that other connection or sealing techniques could be used including, but not limited to, a suitable adhesive and, for example, a suitable adhesive which may be shrink-fitted securing the sleeve into position.

15

The manufacturing process thus results in the provision of well intervention apparatus 10 as is shown in Figure 2D. As the arrangement of the annular sleeve 34 in recess 26 means that the sleeve 34 conforms with the diameter of the box joint of drill pipe 12, the mechanism 10 can easily be inserted in to environments where close tolerances are required whilst allowing for maximisation of drill pipe bore 24. This facilitates higher volumes of injected fluids or hydrocarbon extraction.

20

25

30

Insertion of a work string of drill pipe 12, provided with two well intervention apparatus 10, into a wellbore 50 is shown in Figure 3. As can be seen, box sections 16 the on drill string, upon which the annular sleeves 34 are mounted in recesses 20, pass through the wellbore 50 with only a small amount of tolerance between the outer surfaces 20, 42 and the inner surface 52 of wellbore 50. It will be appreciated that, although two well intervention apparatus 10 as two expandable packers are shown on the work string, any number of well intervention apparatus can be provided on a string. Additionally other tool may be present on the work string and the work string may be referred to as a drill string.

The use of a re-cycled drill pipe 12 in the manufacture of the well intervention apparatus 10 can help reduce the material costs associated with the manufacturing process associated with the well intervention apparatus 10. In addition, by reusing material on the field, material waste involved in the process of recovering hydrocarbons can be reduced. Typically, recycled drill pipe is no longer perfectly circular in circumference with some distortion likely to have occurred during previous use. The machining process to form the recess 20 will, however, result in a milled recess which is substantially circular in circumference allowing for an annular sleeve to be used effectively.

It will also be appreciated that the well intervention apparatus 10 may be formed on newly manufactured drill pipe. In addition, any suitable tubular, such as a casing, liner, tubing or pipe may be used in the manufacture of the well intervention apparatus although it will be appreciated that not all tubular products are provided with box section arrangements at the open end. Instead, some tubular products such as casing are simply provided with annular open ends. It will be understood that the milling process and application

of the sleeve could be achieved with any open end tubular regardless of whether a box section connection is provided or not.

With reference to Figures 4A, 4B, 4C and 4D there is shown the development of another embodiment of a well intervention apparatus 110 during steps in the manufacture process. As with apparatus 10, the apparatus 110 requires provision of a tubular member, in this case a drill pipe 112. In Figure 4A, there is shown a central portion 114, of drill pipe 112. The drill pipe 112 is pre-used drill pipe. The drill string 112 has an annular wall 118 defined by an outer tubular surface 120 and an inner tubular surface 122 which defines a bore 124.

As is shown in Figure 4A, the method of manufacture involves the step of machining a recess 126 into a central portion 114 of the annular wall 118 from outer tubular surface 120. The recess 126 is formed circumferentially around the tubular body 14 and is defined by outer recess surface 128 and end recess surfaces 129A, 129B.

In Figure 4B it can be seen that the method of manufacture subsequently involves the forming of a perforation 130 between the inner tubular surface 122 and the outer recess surface 128. It will be appreciated that this embodiment shows the formed recess 120 arranged in a central position along the longitudinal body of the drill pipe 112, the recess 120 and thus the expandable element may be arranged at any desired point along the drill pipe section 112.

In Figure 4C, there is shown a cross section of two corresponding annular sleeve segments 134A, 134B which can be provided to cooperate together around drill pipe 112 at recess 120 so as when secured together the segments 134A,B form annular sleeve 134.

The segments 134A, B are secured together once in situ around recess 120 by means of longitudinal welded joints 135A,B such that, as is shown in Figure 4D, the segments 134A,B form sleeve 134 having an inner sleeve surface 140 which lies adjacent outer recess surface 128. The formed annular sleeve 134 also has an outer sleeve surface 142 which has a surface level corresponding with outer tubular surface 120. The manufacturing process further involves providing airtight seals 144, 146 which secure the opposing ends 136A, 136B of annular sleeve 134 to the outer recess surface 128 of drill pipe 112 such that a cavity 148 is defined between the inner sleeve surface 140 and outer recess surface 128. Seals 144, 146 are formed by joining the first sleeve end 136A and second sleeve end 136B to outer recess surface 128. In this case, seals 144, 146 are welded joints. Alternatively, sleeve 134 may extend to fill the recess 120 along its length and be affixed at the side walls of the recess 120. The cavity 148 is accessible from the bore 124 through hole 130.

The apparatus 110 can be activated to expand once the drill pipe 112 is in position within a wellbore (as shown in Figure 1) so as to secure the tubular in place and create a sealed area of wellbore. Expansion is by injecting fluid through the port 130 which can be done using a tool or more preferably by pressurising up the drill string from surface having closed off the lower end.

Apparatus 10,110 formed of drill pipe 12, 112 respectively can access wellbore areas with close tolerance distances, the well intervention apparatus 10, 110 does not need such extensive expansion to secure the tubular firmly within the wellbore. As less expansion is needed to deploy the apparatus 10, 110 effectively, there is likely to be a more complete seal between the apparatus 10, 110 and the wellbore wall 152 thus minimising the ongoing risk

of fluid leaking between the sealed wellbore area and the other surrounding wellbore. The wellbore wall 152 may be previously installed tubular such as casing or be formation in an open borehole.

5

The principle advantage of the invention is that it provides a method of well intervention which utilises drill pipe to create isolation barriers in a well.

10 A further advantage of the invention is that it provides well intervention apparatus in which by positioning the annular sleeve in a milled recess such that the outer surface of the annular sleeve is at the same level as the outer surface of the tubular, the apparatus can be run into a well having small clearance tolerances.

15

A further advantage of the invention is that by retrofitting a sleeve to a pre-used tubular such as drill pipe significant savings in costs and materials can be incurred.

20 It will be appreciated to those skilled in the art that various modifications may be made to the invention herein described without departing from the scope thereof. For example, Figures 1A-D illustrate a well intervention apparatus being formed at a tubular end which is provided with a box section of a box and pin
25 connection. However, it will be appreciated that the well intervention apparatus could similarly be formed at a tubular end having a pin connection. In addition, the methods of manufacture detailed above discuss the provision of a perforation after a recess has been milled into the tubular; however, it will be appreciated
30 that the perforation may be drilled prior to the recess being machined. Additionally, reference has been made to shallower and deeper, together with upper and lower positions in the well bore. It

will be recognised that these are relative terms though a vertical well bore is illustrated the method and apparatus apply equally to deviated and horizontal well bores.

CLAIMS

- 5 1. A method of well intervention, in which a work string is run into a well, comprising the steps:
forming a work string from a plurality of sections of drill pipe;
at least one section of drill pipe including an expandable
element located thereon;
10 running the work string into the well and expanding the expandable element to contact a wall of the well.
2. A method according to claim 1 wherein the at least one
section of drill pipe including an expandable element located
15 thereon is manufactured by a process comprising the steps of:
providing the drill pipe having an annular wall with an
outer tubular surface and an inner tubular surface defining a
bore;
forming a circumferential recess in the outer tubular
20 surface of at least one longitudinal segment of the drill pipe,
the recess having at least an outer recess surface;
forming a perforation between the inner tubular surface
and the outer recess surface;
providing an annular sleeve having a first sleeve end, a
25 second sleeve end, an inner sleeve surface and an outer
sleeve surface, wherein the sleeve conforms with the recess;
and
providing airtight seals securing the annular sleeve to
the tubular at the first sleeve end and the second sleeve end
30 thus forming a cavity between the inner sleeve surface and
outer recess surface wherein the cavity is accessible from the

tubular through the perforation to provide the expandable element.

3. A method according to claim 2 wherein the method involves
5 the step of forming the recess at a box section at an open end of the drill pipe.
4. A method according to claim 2 or claim 3 wherein the method
10 includes the steps of forming the recess in a centrally positioned longitudinal portion of the drill pipe, providing the annular sleeve as a first sleeve segment and a second sleeve segment which conform longitudinally to form an annular sleeve, arranging the first and second sleeve segment to conform around the tubular recess and securing the first and
15 second sleeve segments longitudinally to create an annular sleeve which conforms with the annular recess.
5. A method according to any one of claims 2 to 4 wherein the
20 step of securing the annular sleeve involves creating welded joints.
6. A method according to any one of claims 2 to 5 wherein the
25 step of securing the annular sleeve involves application of a suitable adhesive material.
7. An well intervention apparatus comprising:
a tubular having an annular wall with an outer tubular
surface, an inner tubular surface defining a bore, and a
circumferential recess formed in the outer tubular surface of
30 at least one longitudinal segment of the tubular, the recess having an outer recess surface and a perforation between the inner tubular surface and the outer recess surface; and

- an annular sleeve having a first sleeve end, a second sleeve end, an inner sleeve surface and an outer sleeve surface, wherein the sleeve conforms with the recess and is secured to the tubular at the first sleeve end and the second sleeve end such that a cavity is defined between the inner sleeve surface and outer recess surface which is accessible from the bore via the perforation.
- 5
8. A well intervention apparatus according to claim 7 wherein the tubular is drill pipe.
- 10
9. A well intervention apparatus according to claim 7 or claim 8 wherein the tubular is recycled tubular.
- 15
10. A well intervention apparatus according to any one of claims 7 to 9 wherein the annular sleeve is secured to the tubular by welded joints.
11. A well intervention apparatus according to any one of claims 7 to 9 wherein the annular sleeve is secured to the tubular by a suitable adhesive material.
- 20
12. A well intervention apparatus according to any one of claims 7 to 11 wherein the recess is formed at an open end of the tubular.
- 25
13. A well intervention apparatus according to claim 12 wherein the open end is a box section of a box and pin connection.
- 30
14. A well intervention apparatus according to any one of claims 7 to 11 wherein the recess is formed at a centrally positioned longitudinal portion of the tubular.

15. A well intervention apparatus according to claim 14 wherein the annular sleeve is provided as first sleeve segment and a second sleeve segment which are operable to be secured together longitudinally to form an annular sleeve.
- 5 16. A well intervention apparatus according to claim 15 wherein the first sleeve segment and second sleeve segment are welded together to form an annular sleeve.
- 10 17. A well intervention apparatus according to claim 16 wherein the first sleeve segment and second sleeve segment are secured together by a suitable adhesive material to form an annular sleeve.

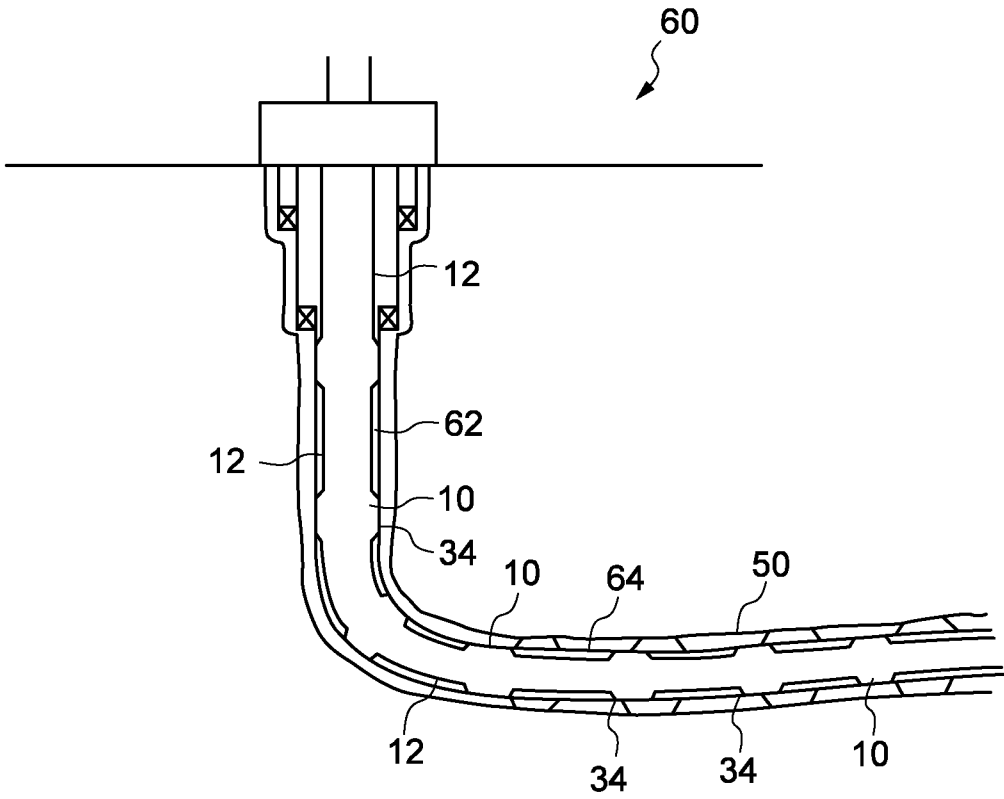

Fig. 1

2/6

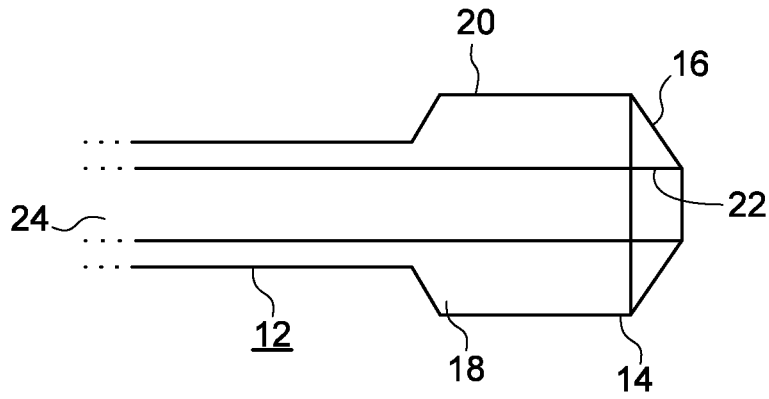

Fig. 2A

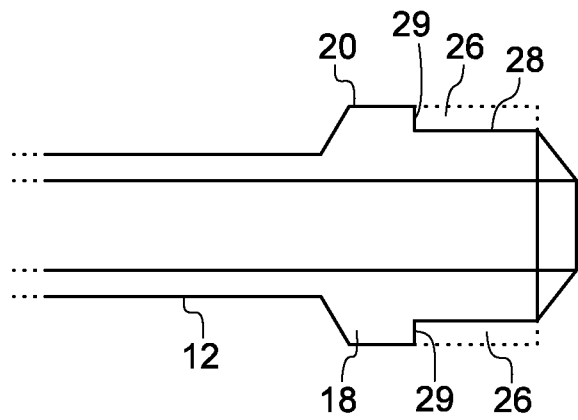

Fig. 2B

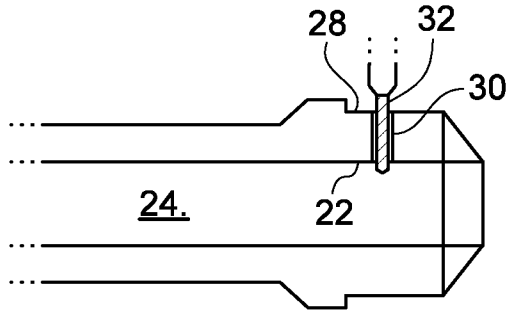

Fig. 2C

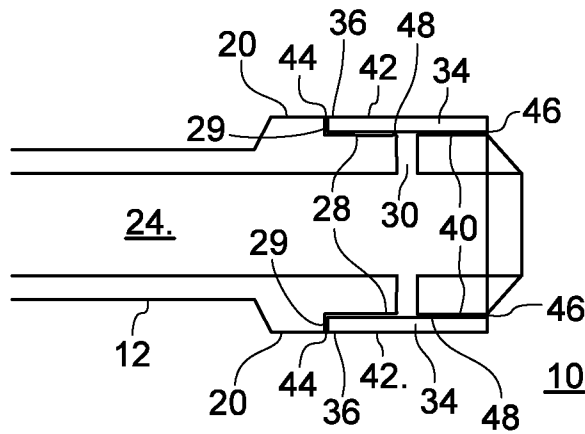

Fig. 2D

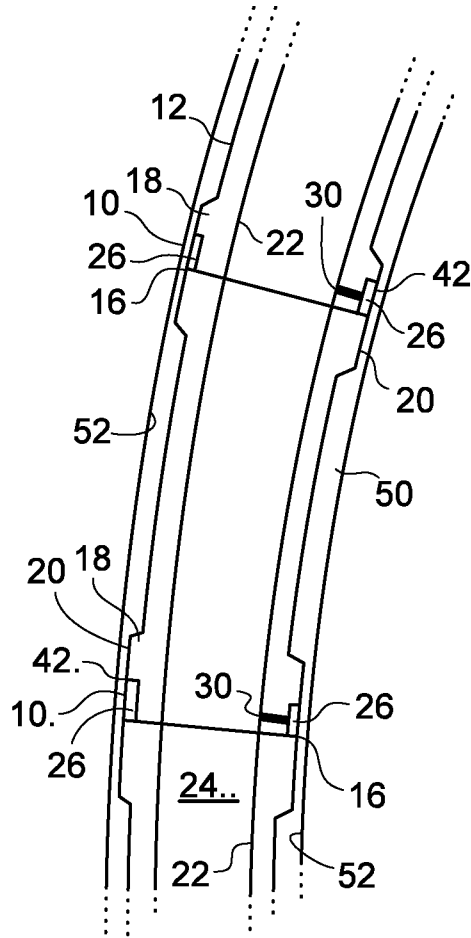

Fig. 3

5/6

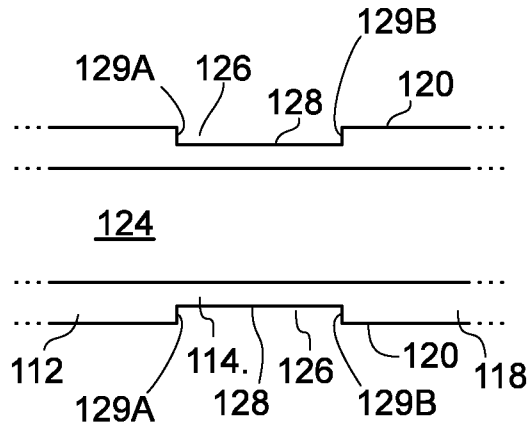

Fig. 4A

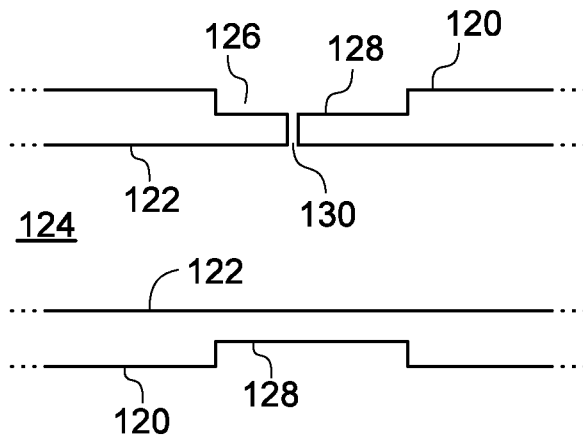

Fig. 4B

6/6

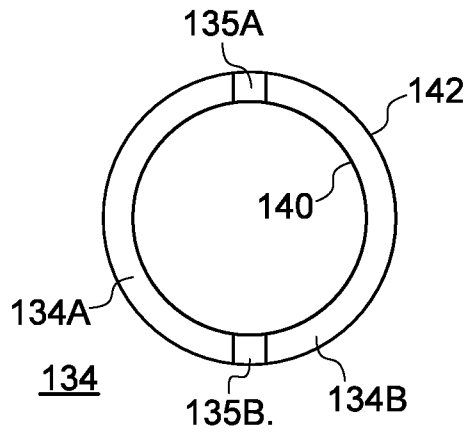

Fig. 4C

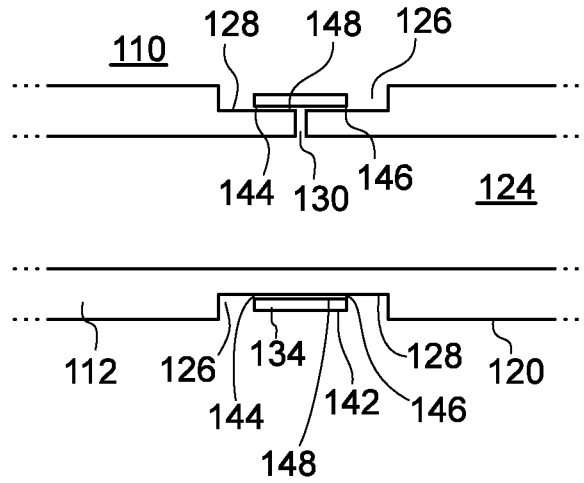

Fig. 4D

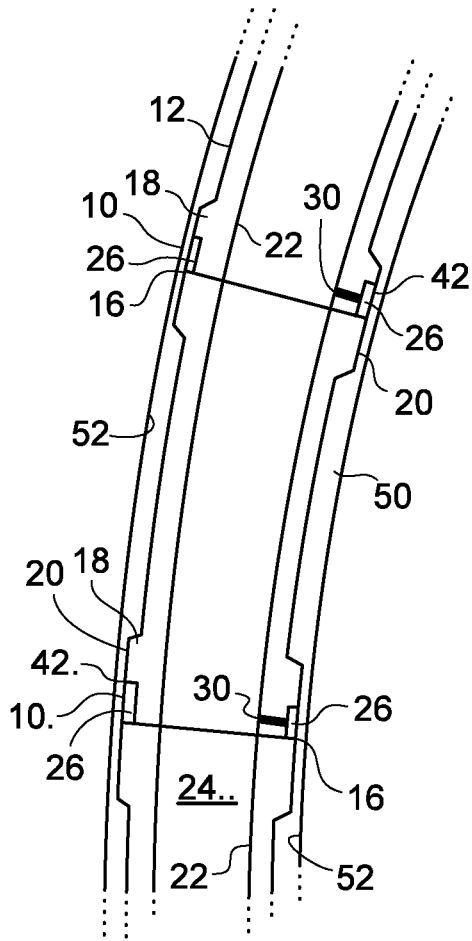

Fig. 3