

Nov. 13, 1951

T. E. McDOWELL ET AL
EXPLOSION-PROOF LIGHTING FIXTURE
HAVING ISOLATED COMPARTMENT
Filed Jan. 13, 1949

2,574,882

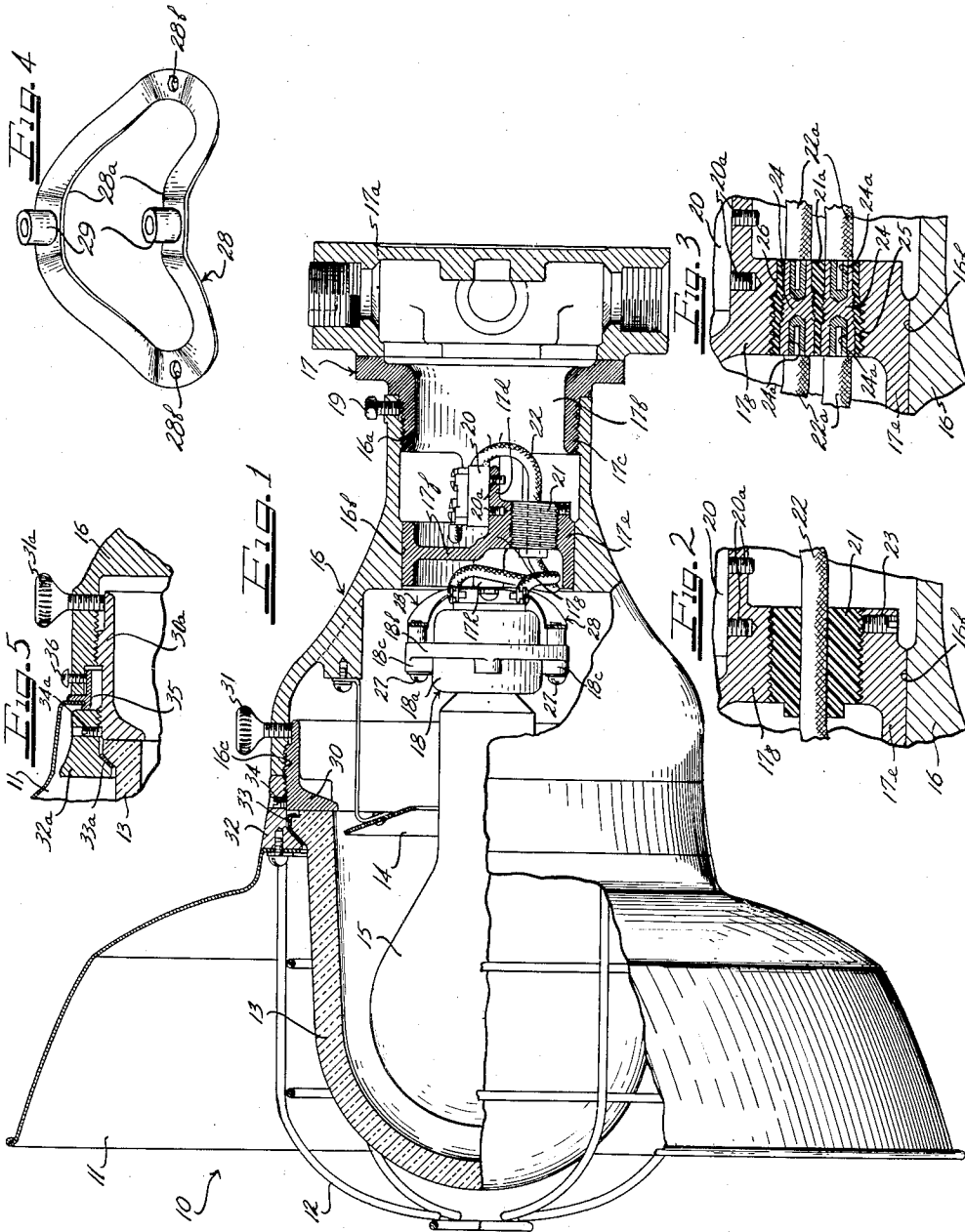

Inventors
THOMAS E. McDOWELL
PHILIP S. ROCKWELL

The Firm of Charles McKillop Attys.

UNITED STATES PATENT OFFICE

2,574,882

EXPLOSION-PROOF LIGHTING FIXTURE HAVING ISOLATED COMPARTMENTS

Thomas E. McDowell and Philip S. Rockwell, Chicago, Ill., assignors to The Pyle-National Company, Chicago, Ill., a corporation of Illinois

Application January 13, 1949, Serial No. 70,624

6 Claims. (Cl. 240—11.2)

1

This invention relates to an illumination apparatus and more particularly to a structure for housing an electric light for use in areas where explosive concentrations of gas vapors are likely to be present.

It is well known that many industries today face a problem of providing adequate illumination in areas having a high concentration of gaseous vapors or in areas containing explosive mixtures of dust-laden air. To that end, so-called explosion-proof lighting fixtures have been provided heretofore which are adapted to provide an incandescent source of light suitably encased so as to reduce the hazards due to the inadvertent transmittal of a flame or spark capable of igniting the explosive mixtures surrounding such a lighting fixture.

The problems confronted by manufacturers of explosion-proof lighting fixtures are manifold inasmuch as it is necessary to conform to a high standard of perfection established by the Underwriters' Laboratories in the face of increased costs of production.

It is an object of this invention to provide an explosion-proof lighting fixture with improved serviceability characteristics and which is completely reliable for its intended purpose.

It is an object of this invention to provide an explosion-proof lighting fixture having a removable wiring canopy which has an especially designed explosion-proof slip joint on one end cooperatively engageable with the lamp housing.

It is a further object of this invention to provide an explosion-proof lighting fixture having a simplified construction whereby replacement of a lamp bulb may be accomplished without necessitating the removal of the lamp reflector.

Another object of this invention is to provide an explosion-proof lighting fixture which may be conveniently serviced in the field.

A further object of this invention is to provide a wiring canopy for an explosion-proof lighting fixture having novel means of accommodating a conductor wire to be connected to a terminal block mounted in the wiring canopy and connected to a lamp accessory.

Another object of the invention is to provide an improved enclosure unit as well as improved mounting means therefor whereby the enclosure unit may be removably mounted on a fixture housing.

Yet another object of this invention is to provide a specially designed wiring canopy capable of receiving in resilient assembly therewith a shock-absorbing mount for a lamp receptacle.

2

Other advantages and objects of the present invention will be manifested to those skilled in the art through reference to the following description and the accompanying drawings which describe and illustrate an explosion-proof lighting fixture embodying the principles of this invention.

On the drawings:

Figure 1 is an elevational view partly broken away and partly in section of an explosion-proof lighting fixture embodying the principles of our invention;

Figure 2 is a sectionalized fragmentary view of a portion of the wiring canopy embodied in the present structure magnified to illustrate the details of construction of the same;

Figure 3 is a fragmentary magnified sectionalized view of a portion of the wiring canopy shown in Figure 2 illustrating one modification of the present invention;

Figure 4 is a perspective view of an especially designed resilient mount embodied in the present structure; and

Figure 5 is an enlarged fragmentary sectionalized view showing an alternative modification of a portion of the structure.

As shown on the drawings:

Referring to Figure 1, an explosion-proof lighting fixture is indicated generally at 10 and comprises an enclosure unit which may include an outer reflector 11, a guard 12 and a globe 13; an inner reflector 14, a bulb 15, a housing 16 and a wiring canopy 17.

As may be seen on the drawing, the housing 16 comprises a hollow substantially bell-shaped member which defines on its large end a chamber for receiving a bulb receptacle 18. The small end of the housing 16 defines a substantially cylindrical bore which is internally threaded as at 16a and which may be machined to form a smooth cylindrical bore, as at 16b, for reasons which will hereinafter be set forth.

The wiring canopy 17 is herein shown as an integral casting having formed on one end thereof a substantially cylindrical portion which may be received generally by the bore effected by the internal bore of the housing 16. The other end of the wiring canopy herein shown defines an enlarged cap portion 17a.

The enlarged cap portion 17a of the wiring canopy 17 is provided with suitable entry apertures for receiving electric conduits in assembly therewith and may also be provided with suitable connecting means for mounting upon a wall or ceiling surface. It will be understood,

of course, that the constructional features of the wiring canopy at the enlarged cap portion 17a may be varied, as for example, by providing a simple cover structure with a central aperture whereby the explosion-proof lighting fixture may be adapted for use as a pendent unit.

As shown in Figure 1, the wiring canopy 17 is provided with an intermediate cylindrical portion 17b which is externally threaded as at 17c. Thus, when the wiring canopy 17 is inserted into the internal bore of the housing 16, the housing and the canopy may be joined in threaded assembly. A set screw 19 is provided to lock the wiring canopy in firm assembly with the housing.

Interiorly of the cylindrical portion of the canopy 17b of the canopy 17 is a flattened portion 17d. A conventional terminal block 20 made of non-conducting material is mounted upon the flattened portion 17d and is held in firm assembly therewith by means of a plurality of screws 20a.

Using the plane of reference on the drawing, the left-hand portion of the wiring canopy 17 is shown as comprising an explosion-proof slip joint 17e, the outside surface of the slip joint being machined in the form of a smooth cylinder so as to be snugly received by the cylindrical bore portion 16b of the housing 16. The longitudinal dimension of the slip joint 17e and the amount of tolerance between the housing 16 and the wiring canopy 17 at the point 16b are critical dimensions which must be maintained in accordance with the specifications prescribed by the Underwriters' Laboratories. Thus, it will be evident that any flame passing through the explosion-proof slip joint 17e will be cooled sufficiently by the time it reaches the other side so as to preclude the possibility of igniting any gaseous vapors or explosive air mixtures.

As may be seen on the drawings, the end of the wiring canopy 17 is partially closed as at 17f. The closure portion 17f is provided with an enlargement as at 17g, the details of which will now be described.

Referring specifically to Figures 2 and 3, the enlargement 17g may be adapted to receive in flame-tight relation therewith a conductor-carrying plug 21. As shown on Figure 2, a conductor conduit 22 is molded integrally with the plug 21 which is made of a moldable material such as "Bakelite" or the like, and the longitudinal dimension of the internal bore defined by the conductor conduit 22 within the plug 21 is maintained in accordance with the specifications of the Underwriters' Laboratories. The plug 21 may be assembled with the wiring canopy 17 in various ways. However, as shown herein, the enlargement 17g is drilled and tapped and the plug 21 is threaded upon its outer periphery so as to permit firm threaded assembly of the two members. The plug 21 may be locked in place by means of a set screw 23. It will be understood, of course, that the plug 21, if non-threaded, could be assembled in other manners, as for example, by cementing.

Referring specifically to Figure 3, a modified conductor plug 21a is shown having bushings 24 made of conducting material molded integrally therewith. The bushings may be suitably formed to define recesses as at 24a for receiving in soldered connection therewith the terminal end of the conductors indicated by the reference numeral 22a. It will be understood, of course, that the bushings 24 may also be threaded into the plug 21a, and further that the plug 21a may be assembled with the wiring canopy 17 either in

threaded relationship as is indicated at 25, or by sealing the plug 21a with "Glyptal" or some other suitable cement as at 26.

It may be noted that the plugs 21, 21a may be formed of any suitable plastic insulating material, for example "Bakelite," and comprise individual articles of manufacture which can be quickly replaced in a lamp structure if need be, for example, when the conductor wires are damaged and need to be replaced.

Referring again to Figure 1, the lamp receptacle 18 is shown as comprising a body portion 18a having the usual terminal connectors and is surrounded by an integral annular ring 18b which is provided with suitable bosses as at 18c. The bosses 18c may be suitably formed to define openings for receiving mounting screws 27. The lamp receptacle is assembled within the light structure by turning the screws 27 into the threaded receptacle of an especially designed resilient mounting member 28.

The construction of the mounting member 28 may be seen in greater detail in Figure 4. The member 28 takes the shape of a ring of springy, resilient metal and is bent to form two upstanding portions indicated at 28a. A pair of receptacle mounts 29 are secured to the upstanding portions 28a of the mounting 28 and are adapted to receive the screws 27 in threaded relationship therewith. The receptacle mount 28 is further provided with a pair of apertures 28b through which suitable fastening means may be passed to secure the resilient mount 28 to the wiring canopy 17 as at 17h.

Thus, it will be evident that the bulb 15 and the bulb receptacle 18 may be subjected to strong shock without damage because of the shock absorbing characteristics afforded by the resilient inter-relation of the lamp, the bulb receptacle 18, and the wiring canopy 17.

Referring now to the left-hand portion of Figure 1, the large end of the bell-shaped housing 16 is shown as providing an internally threaded bore 16c. An annular clamping ring 30 is threadedly received by the threaded bore 16c of the housing 16 and may be locked in firm assembly therewith by means of a knurled screw 31. The clamping ring 30 is provided with a flat shoulder portion which is adapted to receive in abutting assembly therewith the globe 13. The glass-to-metal contact provided between the globe 13 and the clamping ring 30 should preferably be within the dimensional tolerances established by the specifications of the Underwriters' Laboratories.

The clamping ring 30 receives in threaded assembly therewith a globe retaining ring 32 which is also annular in form and has an internally threaded bore. The globe retaining ring 32 cooperatively engages a corresponding shoulder portion of the globe 13, thereby restraining the globe against longitudinal displacement and urging it into snug flame-tight assembly with the clamping ring 30. A cushion ring 33 is interposed between the globe retaining ring 32 and the globe 13 and preferably takes the form of an annular ring of metal.

Because the joint defined between the globe 13 and the clamping ring 30 must of necessity be explosion-proof, it is highly desirable that this joint be established in semi-permanent form in the factory so as to preclude disassembly by unauthorized persons in the field. To that end, the globe retaining ring 32 is suitably drilled and tapped to receive one or more set screws 34 which

may be tightened upon the clamping ring 30. By recessing the set screws 34 into the globe retaining ring 32, "Glyptal," or some other suitable cement, may be placed over the set screws 34 so as to lock the seal and conceal the screw from the view of a casual observer. This construction safeguards against any inadvertent disassembly of the explosion-proof joint inasmuch as anyone desiring to re-lamp the structure may conveniently remove the entire reflector, guard, globe and ring assembly from the housing 16 by loosening the knurled screw 31 and disengaging the clamping ring 30 from the housing 16.

Some explosion-proof lighting fixtures are manufactured to assume proportions of cumbersome size and are somewhat unwieldy due to the large diameter of the outer reflector 14. Thus, when expediting the re-lamping procedure in larger size lighting fixtures, the aforesaid assembly of the enclosure unit has certain servicing disadvantages. In order to overcome these difficulties, the present invention may be modified to provide a semi-permanently assembled outer reflector as shown in Figure 5.

Referring specifically to Figure 5, a modified clamping ring 30a is shown which has two threaded portions in spaced relation upon an outer peripheral surface. The clamping ring 30a is threadedly received by the internally threaded bore of the housing 16 and may be locked in place by a knurled screw 31a. The clamping ring 30a is also provided with a flat shoulder portion for receiving the globe 13 in explosion-proof assembly therewith. The globe 13 is retained against the clamping ring 30a by means of a globe retaining ring 32a which is internally threaded for engagement with the clamping ring 30a. A cushion ring 33a is interposed between the globe retaining ring and the globe, and the globe retaining ring may be locked in position upon the clamping ring by means of a plurality of set screws 34a in the same manner as previously described. An additional reflector ring 35 is shouldered against the housing 16.

As may be seen on Figure 5, the reflector ring 35 is annular in shape and is provided with a flange which may lie in abutting relationship between the inturred edge of the outer reflector 11 and the outer shoulder of the housing 16. The reflector ring 35 is further provided with a shallow annular groove suitable for receiving the inturred edge of the outer reflector 11. The ring 35 may be locked in firm assembly with the housing 16 by means of one or more screws 36.

It will be evident that this construction permits re-lamping without necessitating the removal of the outer reflector 11 since the knurled screw 31a may be released and the entire enclosure structure comprising the guard 12, the globe 13, the globe retaining ring 32a and the clamping ring 30a may be removed by disengaging the clamping ring 30a from the threaded bore of the housing 16.

It will be evident that we have described an improved explosion-proof lighting fixture having novel features which facilitate serviceability characteristics and which may be produced with greatly reduced expenditure of manufacturing effort. Although we have resorted to details in the description of our invention for the sake of clarity, it will of course, be understood that the present embodiment is shown way of example only and, therefore, it should be understood that we desire to be limited only by the scope of the appended claims and prior art.

We claim as our invention:

1. In an explosion-proof lighting fixture, the improvement comprising, a housing having a bore formed with an annular reduced diameter portion of predetermined width therein, a wiring canopy in said bore having a smooth cylindrical sleeve portion the same width as said annular portion slidably received by said annular portion and forming together therewith an explosion-proof joint to isolate opposite ends of said housing, and an externally threaded conductor plug having conductor means integrally imbedded therein and extending from end to end thereof, said cylindrical sleeve portion of said wiring canopy having an axially extending threaded aperture receiving said conductor plug in flame-proof assembly and establishing electrical communication between opposite ends of said housing.

2. In an explosion-proof lighting fixture, the improvement comprising, an open-ended housing having a reduced diameter annular portion of predetermined width formed therein and having threaded portions adjacent opposite open ends thereof, a wiring canopy having a threaded cap portion and a smooth cylindrical slip joint portion axially spaced apart from one another, said slip joint portion being of substantially the same width as said annular portion, said canopy having said threaded cap portion threadedly engageable in one end of said housing and forming thereby a flame-proof joint, said slip joint portion axially spaced apart from one another, said canopy having an axially extending threaded therewith a flame-tight joint, a closure means threadedly engaged in the other end of said housing to form a flame-tight joint and thereby to complete the isolation of the opposite ends of said housing, and an externally threaded conductor plug having conductor means integrally imbedded therein and extending from end to end thereof, said slip joint portion of said wiring canopy having an axially extending threaded aperture therein receiving said conductor plug in flame-tight assembly to establish electrical communication between opposite ends of said housing.

3. In an explosion-proof lighting fixture, a housing having a bore open at one end formed therein and a threaded portion adjacent the open end of said bore, an externally threaded clamping ring having a portion thereof threaded into said threaded portion of said bore and having a radially inwardly extending shoulder on the end thereof, a globe having an annular portion adapted to abut said shoulder in flame-tight assembly, and an internally threaded globe retaining ring threaded on said clamping ring to retain said globe in assembly with said clamping ring, said threaded-together portions of said housing, said clamping ring, and said globe retaining ring further constituting a flame-proof joint to complete the isolation of said bore of said housing, said clamping ring together with said globe and said globe retaining ring being removable from said housing as an integral sub-assembly.

4. In an explosion-proof lighting fixture, a housing having a bore open at one end formed therein and a threaded portion adjacent the open end of said bore, an externally threaded clamping ring having a portion thereof threaded into said threaded portion of said bore and having a radially inwardly extending shoulder on the end thereof, a globe having an annular portion adapted to abut said shoulder in flame-proof assembly, and an internally threaded globe-retaining ring

7

threaded on said clamping ring to retain said globe in assembly with said clamping ring, and to abut against the end of said housing in flush assembly therewith, said threaded-together portions of said housing, said clamping ring and said globe retaining ring further constituting a flame-proof joint to complete the isolation of said bore of said housing, said clamping ring together with said globe and said globe retaining ring being removable from said housing as an integral sub-assembly.

5. In an explosion-proof lighting fixture, a housing having a bore open at one end formed therein and a threaded portion adjacent the open end of said bore, an externally threaded clamping ring having a portion thereof threaded into said threaded portion of said bore, and having a radially inwardly extending shoulder on the end thereof, a globe having an annular portion adapted to abut said shoulder in flame-proof assembly, an internally threaded globe retaining ring threaded on said clamping ring to retain said globe in assembly with said clamping ring and to abut against the end of said housing in flush assembly therewith, said threaded-together portions of said housing, said clamping ring and said globe retaining ring further constituting a flame-proof joint to complete the isolation of said bore of said housing, a reflector and a globe guard mounted on said globe retaining ring, said clamping ring together with said globe retaining ring, said globe, said reflector and said globe guard being removable from said housing as an integral sub-assembly.

6. An explosion-proof lighting fixture comprising an open ended housing having a reduced diameter annular rib formed therein and having threaded portions adjacent the opposite ends thereof, said annular rib being of a predetermined width, a wiring canopy having a threaded cap portion and a smooth cylindrical slip joint portion axially spaced apart from one another, said canopy having said threaded cap portion threadedly engaged in one end of said housing to form

8

a flame-tight joint and having said slip joint portion slidably received by said rib to form together therewith a second flame-tight joint, to isolate opposite ends of said housing, an externally threaded conductor plug having conductor means extending from end-to-end thereof and being integrally imbedded therein, said slip joint portion of said wiring canopy having an axially extending aperture receiving said conductor plug in flame-proof assembly to establish electrical communication between opposite ends of said housing, an externally threaded clamping ring having a portion thereof threaded into the other end of said bore, said clamping ring having a radially extending shoulder on the end thereof, a globe having an annular portion adapted to abut said shoulder in flame-proof assembly and an internally threaded globe retaining ring threaded on said clamping ring to retain said globe in assembly with said clamping ring, said threaded-together portions of said other end of said housing, said clamping ring and said globe retaining ring constituting a flame-proof joint to complete the explosion-proofing of said housing, said clamping ring together with said globe and said globe retaining ring being removable from said housing as an integral sub-assembly.

THOMAS E. McDOWELL.
PHILIP S. ROCKWELL.

REFERENCES CITED

The following references are of record in the file of this patent:

UNITED STATES PATENTS

Number	Name	Date
1,730,836	Wyman	Oct. 8, 1929
1,821,406	Sawin	Sept. 1, 1931
2,094,394	Bissell	Sept. 28, 1937
2,278,974	Christensen	Apr. 7, 1942
2,316,835	Blood	Apr. 20, 1943
2,339,670	Benson	Jan. 18, 1944
2,422,379	Westman	June 17, 1947

Certificate of Correction

Patent No. 2,574,882

November 13, 1951

THOMAS E. McDOWELL ET AL.

It is hereby certified that error appears in the printed specification of the above numbered patent requiring correction as follows:

Column 5, line 38, for "in interposed" read *is interposed*; column 6, line 24, for "canpoy" read *canopy*; lines 26 and 43, for "axilally" read *axially*; lines 32 and 33, for "axially spaced apart from one another, said capony having an axially extending threaded" read *being concurrently received by said annular portion in slidable relation to form together*;

and that the said Letters Patent should be read as corrected above, so that the same may conform to the record of the case in the Patent Office.

Signed and sealed this 4th day of March, A. D. 1952.

[SEAL]

THOMAS F. MURPHY,
Assistant Commissioner of Patents.