

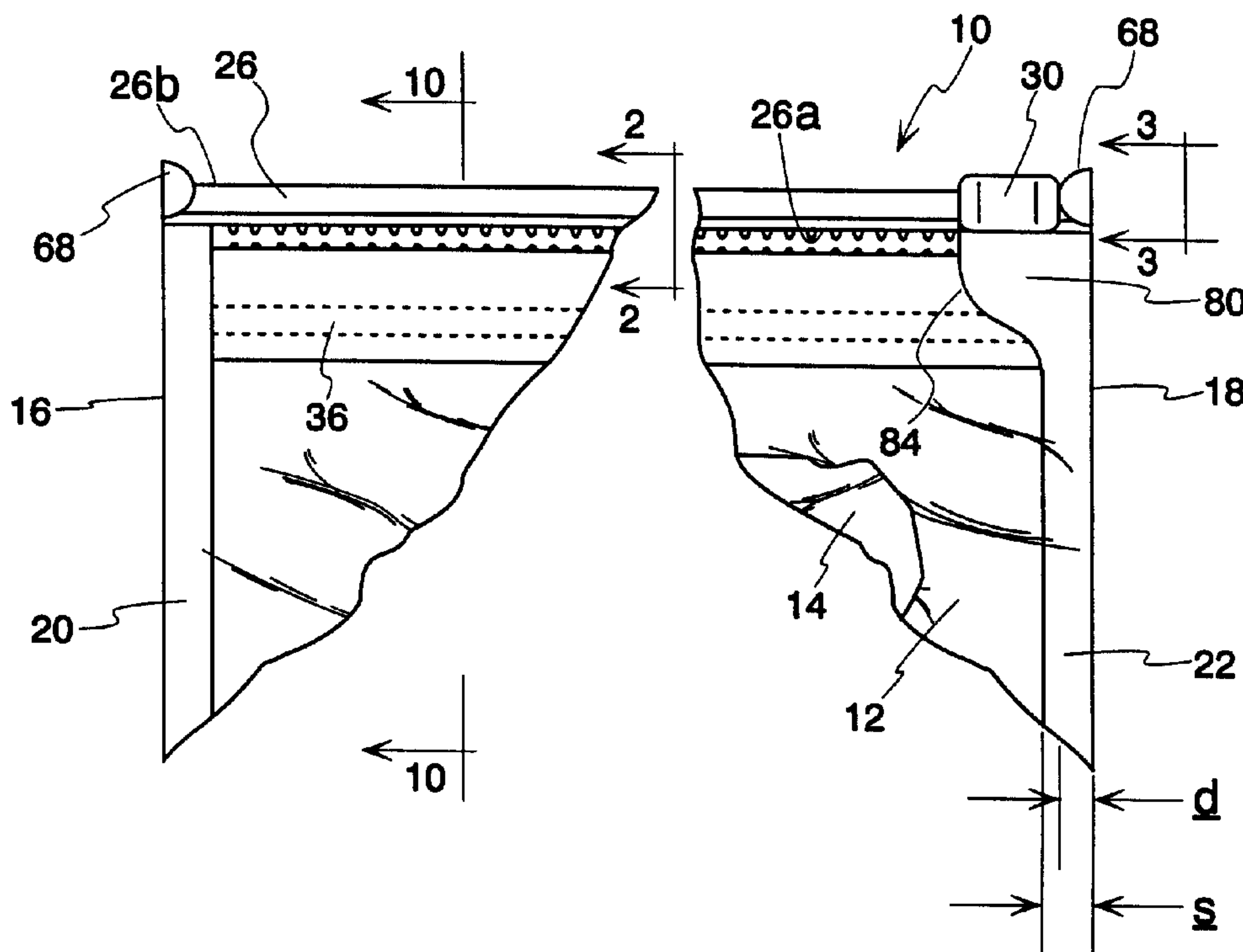

(22) Date de dépôt/Filing Date: 2001/09/20
(41) Mise à la disp. pub./Open to Public Insp.: 2002/03/22
(30) Priorité/Priority: 2000/09/22 (09/668,070) US

(51) Cl.Int.⁷/Int.Cl.⁷ B65D 33/25
(71) Demandeur/Applicant:
KRAFT FOODS HOLDINGS, INC., US
(72) Inventeurs/Inventors:
LEE, STEVEN C., US;
KINIGAKIS, PANAGIOTIS, US
(74) Agent: MCFADDEN, FINCHAM

(54) Titre : FERMOIR COULISSANT POUR EMBALLAGE SOUPLE
(54) Title: FASTENER CLOSURE ARRANGEMENT FOR FLEXIBLE PACKAGES



(57) Abrégé/Abstract:

A flexible package is provided with a slider fastener closure. A side seal forming the package is enlarged at its upper end to provide a smooth transition of product dispensed from the package, and to shield the slider during dispensing. The enlarged side seal portion is spaced from the fastener tracks. The fastener tracks are deformed to provide a stop, spaced from the side seals, to limit slider movement. A stop of reduced area, enlarging the package opening, is made possible.

FASTENER CLOSURE ARRANGEMENT FOR FLEXIBLE PACKAGES**Abstract Of The Disclosure**

A flexible package is provided with a slider fastener closure. A side seal forming the package is enlarged at its upper end to provide a smooth transition of product dispensed from the package, and to shield the slider during dispensing. The enlarged side seal portion is spaced from the fastener tracks. The fastener tracks are deformed to provide a stop, spaced from the side seals, to limit slider movement. A stop of reduced area, enlarging the package opening, is made possible.

FASTENER CLOSURE ARRANGEMENT FOR FLEXIBLE PACKAGES**BACKGROUND OF THE INVENTION****1. Field of the Invention**

The present invention pertains to the closure
5 of flexible packages, such as plastic bags, and in
particular to fastener closures employing sliders.

2. Description Of The Related Art

With the recent emphasis in providing consumers
with bulk quantities of various commodities, such as food
10 products, reclosable packages have become increasingly
popular. One of the most popular means of providing
reclosability is to employ zippers of various types,
particularly zippers which are compatible with flexible
packages of plastic film construction. Manufacturers of
15 food products and other commodities are concerned with
filling the contents of a flexible package as quickly and
economically as possible. It is important that the
opening provided by the fastener be made as large as
practically possible. Consumers or other end users also
20 prefer large sized openings for easy extraction of
products from the package interior. Even with large
openings, however, products within the package may
interfere with fastener operation when product poured or
otherwise dispensed from the package becomes entrained in
25 the fastener components.

Other improvements to flexible reclosable
packages are being sought. For example, when handling
products comprised of numerous small pieces, such as
shredded cheese or cereal, for example, it is generally
30 desirable to have the package formed into a pouch which
is open at one end, or along one side, so as to allow
product to be poured or shaken through the reclosable
opening. It is desirable that the product be allowed to
freely flow past the reclosable opening. Preferably, the
35 path taken by the product within the package should be
made as smooth as possible.

-2-

Although improvements have been made in the art of plastic welding and joining, manufacturers of consumer products employing high speed production techniques are continually seeking improved package forming methods and equipment. Concern has been focused on the formation of stop members which limit the travel of a sliding closure traveling along fastener tracks. Any reduction in the time needed to form these and other package features can result in substantial cost savings.

10

SUMMARY OF THE INVENTION

It is an object of the present invention to provide an improved fastener closure for flexible packages.

Another object of the present invention is to provide reclosable packages having fastener sliders which are protected as the package contents are poured out or otherwise extracted.

A further object of the present invention is to provide a reclosable package having improved arrangements for hanging display.

Yet another object of the present invention is to provide a reclosable plastic package having a slider fastener with improved containment of the slider in a manner which also optimizes the size of the bag opening.

A further object of the present invention is to provide a plastic bag having a slider fastener with an improved end or "crush" seal of the fastener tracks.

These and other objects of the present invention are attained in a reclosable flexible package comprising:

opposed front and rear panels having sides and joined together to form an interior and a package opening communicating with said interior;

first and second interlockable fastener tracks configurable in an interlocked, closed position and an unlocked open position;

-3-

a slider movable along said fastener tracks to configure said tracks in said interlocked position so as to close said opening and to configure said fastener tracks in said unlocked position so as to allow access
5 through said opening to said package interior;

said fastener tracks having opposed ends located adjacent said opposed sides of said front and said rear panels;

stops adjacent said ends of said fastener
10 tracks to interfere with and prevent travel of said slider beyond said fastener tracks;

a side seal of pre-selected width joining together one side of said front and said rear panels, said side seal having an enlarged end portion of enlarged
15 width adjacent said fastener tracks, with at least a part of said enlarged end portion disposed below said fastener tracks; and

wherein said enlarged end portion is disposed beneath the substantial entirety of said slider and
20 shields said slider, deflecting product being discharged from said package interior, around said slider.

It has been determined that, in a practical commercial environment, it is difficult to employ conduction heat sealing techniques to form the slider
25 stop. It is preferred that the stop be formed using ultrasonic sealing techniques, as these afford greater control over dimension and shape. This is important when the maximum number of advantages accorded the present invention are being sought, since the mass, and
30 particularly the frontal surface area of the stop is reduced to the greatest extent possible.

BRIEF DESCRIPTION OF THE DRAWINGS

FIG. 1 is a fragmentary front elevational view of a flexible package according to principles of the
35 present invention;

FIG. 2 is a fragmentary cross-sectional view taken along the line 2-2 of FIG. 1;

-4-

FIG. 3 is a fragmentary end view indicated by line 3-3 of FIG. 1;

FIG. 4 is fragmentary front elevational view showing construction of the flexible package;

5 FIG. 5 is a top plan view of the slider member;

FIG. 6 is a front elevational view thereof;

FIG. 7 is an elevational view from one end thereof;

10 FIG. 8 is an elevational view from the other end thereof;

FIG. 9 is an end view of a fastener track sub-assembly;

15 FIG. 10 is a cross-sectional view, in schematic form, taken along the line 10-10 of FIG. 1 with the slider moved to the left;

FIG. 10a is a fragmentary view, of FIG. 10 shown on an enlarged scale;

FIGS. 10b and 10c show alternative seal constructions;

20 FIG. 11 is a fragmentary front elevational view showing contents being poured from the flexible package;

FIG. 12 is a fragmentary front elevational view showing contents of a prior art package;

25 FIG. 13 is a fragmentary front elevational view showing a flexible package according to principles of the present invention; and

FIG. 14 is a front elevational view of an alternative embodiment of a flexible package according to principles of the present invention.

30 **DETAILED DESCRIPTION OF THE PREFERRED EMBODIMENT**

Referring now to the drawings and initially to FIGS. 1-8, a flexible package illustrating principles of the present invention is generally indicated at 10. Flexible package 10 preferably comprises a plastic bag 35 having front and back panels 12, 14 joined together at the left end by a side seal 20 and at the right end by a side seal 22. Side seal 20 is preferably of conventional

-5-

conduction heat-sealed construction, having a generally constant width throughout. Panels 12, 14 are further joined together at their bottom ends by a bottom seal 24 (see Fig. 10) extending between side seals 20, 22, as is known in the art. Alternatively, the bottom seal can be replaced by a fold line with panels 12, 14 being formed from a continuous sheet of plastic material.

The upper end of flexible package 10 features a reclosable opening including a slide fastener arrangement with fastener tracks 26, 28 and a slider 30, all preferably of polyolefin material. The slider 30 is slidable along the fastener tracks, causing the fastener tracks to interlock or mate (as shown in Fig. 2) for closure of the flexible package and to unmate or separate to open the flexible package for access to contents in the package interior. As will be seen herein, features associated with the fastener slider arrangement allow an unprecedented enlarged opening of the flexible package. The enlarged package opening made possible by the present invention benefits manufacturers filling the package, as well as consumers dispensing product from the interior of the flexible package. In the preferred embodiment shown, the fastener tracks are also referred to as "zipper" tracks.

The flexible package according to principles of the present invention has found immediate commercial acceptance for use with food products, including perishable food products, such as cheese. Accordingly, it is generally preferred that the flexible package includes an hermetic seal 36 in the form of a peelable seal as taught in commonly assigned United States Patent Nos. 5,014,856; 5,107,658 and 5,050,736, the disclosures of which are incorporated by reference as if fully set forth herein.

As mentioned above, flexible package 10 preferably comprises a bag having panels 12,14 formed from plastic sheet material. The sheet material can be of a single material type, such as polyolefin materials

-6-

including polyethylene and polypropylene, but preferably comprises a laminate assembly of several different material types, as is known in the art to provide a barrier to moisture as well as certain gases, such as oxygen or inert fillers of the types used with food products. Other types of laminate films, such as those known in the art to preserve food freshness, may be employed. Where the contents of the flexible package are not perishable or where other considerations may dictate, the panels 12, 14 can be constructed without regard to gas or vapor barrier properties. FIGS. 2 and 3 indicate that it is generally preferred that the fastener tracks be joined to web-like flanges which, in turn, are joined to panels 12, 14 as will be described below with reference to Fig. 10.

Referring now to FIGS. 5-8, fastener slider 30 has a top wall 44, a shorter side wall 46 and a longer side wall 48, cooperating to define an internal cavity 50 for receiving the fastener tracks 26, 28. As can be seen by comparing the end views of FIGS. 7 and 8, a first end 54 of the slider defines a cavity which is generally rectangular. The opposed end 56 (shown in Fig. 8) defines a cavity which is generally arrowhead or A-shaped, as indicated by reference numeral 50b, conforming to the outline of the interlocked fastener tracks shown in Fig. 2. When the slider 30 of Fig. 1 is moved to the right, end 56 is at the leading end of the slider and the fastener tracks 26, 28 are unlocked, thus opening the flexible package 10. Conversely, as slider 30 of Fig. 1 is moved to the left, end 54 (shown in Fig. 7) is made the leading end, and fastener tracks 26, 28 are interlocked in the manner indicated in Fig. 2, to close the flexible package.

Referring again to FIGS. 2, 7 and 8, a number of features cooperate to maintain slider 30 captive on fastener tracks 26, 28. As can be seen for example in FIG. 8, a pair of upwardly facing stepped portions 62 are formed on either side of the slider cavity. Inwardly

-7-

extending protrusions 64 are located at the other end of the slider. Protrusions 64 and stepped portions 62 engage the bottoms 26a and 28a (see FIG. 2) of fastener tracks 26, 28, as can be seen for example in FIG. 10.

5 The engagement of the stepped portions 62 and the protrusions 64 with the bottoms of the fastener tracks prevents the slider from being upwardly dislocated from the fastener tracks.

Referring to FIGS. 1, 3 and 13, the ends of the
10 of the fastener tracks are deformed or "crushed" to form stops 68. Preferably, stops 68 are formed by the application of ultrasonically generated heat and pressure to the ends of fastener tracks 26, 28. It has been found that the use of present day conduction heat sealing
15 techniques does not provide the control needed to attain the intricate, close tolerance design of stop members according to principles of the present invention. Further, it has been found that the use of present day conduction heat sealing techniques immediately adjacent
20 previously formed stop members tends to distort the stop members, oftentimes to an extent rendering the stop members unacceptable from a quality control standpoint. As will be seen herein, stops 68 are configured for maximum efficiency, having the smallest front elevational
25 surface area (i.e., the surface area visible in FIGS. 1 and 13, for example) which is adequate for containing slider 30 on the fastener tracks.

Referring to FIG. 3, the sides of the fastener tracks are softened and compressed at stop faces or sides
30 72 so as to impart a pre-selected width w and an upwelling displacement u above the upper surfaces 26b, 28b of fastener tracks 26, 28 (see FIG. 2). The material displaced above the upper surface of the fastener tracks interferes with the top wall 44 and ends of slider 30 to
35 limit its sideways travel.

With reference to FIG. 3, the slider stop 68 (that is, the deformed portion of fastener tracks 26, 28) is carefully configured so as to avoid deformation of the

-8-

bottom surfaces 26a, 28a of the fastener tracks. With reference to FIG. 1, the lower ends of the fastener tracks extend undeformed, substantially to the side edges 16, 18 of the flexible package 10. FIG. 1 shows slider 5 30 "parked" at a fully opened position, with end 56 contacting the stop 68 located at the right hand end 22 of the flexible package. Stop members 68 and the undisturbed bottom surfaces 26a, 28a of the fastener tracks in the area of stop members 68 cooperate to 10 captivate slider 30 on the fastener tracks, preventing its unintentional removal from flexible package 10.

It is preferred that the bottom edges 26a, 28a remain undeformed also for that portion extending beyond slider 30, and underneath at least a portion of the right 15 hand stop 68. With reference to FIG.3, a gap g is formed between the bottom edges of the fastener tracks and the top portion 81 of side seal 22. As can be clearly seen in FIG. 3, the stop 68, formed by ultrasonic techniques, is separated by a substantial distance from the side 20 seal, which is typically formed using conduction heat seal techniques found to be incompatible with the precise, high resolution ultrasonic techniques used to form stop 68. A second stop 68 formed at the left hand end 16 of flexible package 19 is constructed in a similar 25 fashion and extends beyond the end 54 of slider 30 when the slider is moved fully to the left, closing the upper end of the flexible package. As will be explained in greater detail herein, separation of the "crush" operation performed on the fastener tracks to form stops 30 68 from the conduction heat sealing operation to form the enlarged side seals, allows stops 68 to take on a reduced size, effectively extending the size of the package opening, without sacrificing ability of the stops to effectively retain slider 30 on the fastener tracks.

35 Referring to FIGS. 1 and 4, side seal 22 includes an upper enlarged or tapered portion 80 having a width substantially greater than the lower end of side seal 22, sufficient to underlie the substantial entirety

-9-

of slider 30 when the slider is fully moved to the "parked" position as shown in FIG. 1. The width of the enlarged, tapered portion 80 ranges between 200% and 400% (or more for very narrow side seals, e.g., 2 mm or less) of the width s of side seal 22 and most preferably ranges between 250% and 300% of the side seal width s.

The enlarged, tapered end 80 of side seal 22 has an S-shaped or double re-entrant bend contour 84 which partly defines the package interior. With reference to FIG. 11, the curved edge 84 of the enlarged side seal portion 80 provides a smooth transition at the corner of the package opening, preventing product entrapment within the flexible package. As those skilled in the art will appreciate, the smooth transition at the opening corner is especially beneficial for flexible packages, where shaking techniques otherwise suitable for rigid packages, are rendered largely ineffective by flexible panels 12, 14 and especially panels of very thin, unsupported material which are likely to collapse in use.

The smooth transition provided by curved edge 84 also deflects or guides product 86 away from slider 30 as product is poured or otherwise removed from flexible package 10. This prevents contamination of mating surfaces of the slider and the fastener tracks, which would otherwise deteriorate the ability of slider 30 to move freely, performing interlocking and unlocking of the fastener tracks. As indicated in FIG. 12, in prior art arrangements product 86 is allowed to freely contact the bottom end of slider 30, a condition which is avoided by flexible packages according to principles of the present invention.

Preferably, fastener tracks 26, 28 are "crushed" to form stop member 68, using conventional ultrasonic heating equipment which allows for a highly accurate shaping of the stop member as well as withdrawal of the deformation area away from the bottom surfaces 26a, 28a as shown, for example, in FIG. 3. As can be

-10-

seen for example in FIG. 1, the width of stop member 68 is considerably less than the enlarged tapered portion 80 of side seal 22, and preferably is of a smaller width than that of the narrower major portion of side seal 22.

5 With reference to FIG. 1, the width d of stop member 68 is less than the width s of side seal 22. Preferably, stop member width d ranges between 50% and 200% of the width s of side seal 22. Preferably, the width w of the stop member 68 (i.e., the "crush" dimension) ranges

10 between 25% and 80% of the width z of the fastener tracks, as illustrated in FIG. 3. The amount of upward displacement or upwelling u is approximately at least as great as the thickness of upper wall 44. It should be kept in mind that the total mass of the stop must be

15 sufficient to hold the slider captive.

The stop member 68, in addition to having a reduced width d in front elevational view and a small width w in end view (see FIG. 3), has a sufficiently smaller mass and frontal surface area than stops employed

20 in the prior art. This construction allows the slider 30 to be moved to an extreme position immediately adjacent the edge 22 of flexible package 10, thus maximizing the package opening, allowing for easier removal of the package contents. This reduced size of stop 68 also

25 contributes to the precision of the ultrasonic heating and formation of the stop member, needed to attain required precise dimensions. Further, from a manufacturing standpoint, the dwell time to melt and shape the stop 68 is substantially reduced, contributing

30 to the overall efficiency for the package manufacturer.

In contrast to the present invention, prior art stop members have been formed by "crushing" the entire fastener profile, including the bottom surfaces 26a, 28a. In addition, even if ultrasonic techniques are employed

35 for the stop member, prior art side seals (formed using conduction heat seal techniques and much larger, oftentimes three to four times larger than side seals according to the present invention) were typically

-11-

overlaid with the stop, contributing to a substantial distortion of the stop structure. Even if the prior art side seals were made to stop short of the fastener tracks, the relatively high level of conduction heating in the immediate proximity of the stop have been found to cause a distortion of the stop, degrading control over its size and shape. These disadvantages are avoided with practice of the present invention, where the small, compact size of the stop is employed, and the gap g is formed between undeformed fastener bottom surfaces 26a, 28a and the enlarged seal portion 80.

Turning now to FIGS. 4, 9 and 10, and initially to FIG. 9, the fastener tracks are preferably formed from a sub-assembly generally indicated at 70 in which the fastener tracks 26, 28 are provided with corresponding fastener flanges 72, 74. The fastener flanges 72, 74 are co-extensive with the fastener tracks 26, 28 and take the form of a plastic web to be heat sealed to the panels 12, 14. As can be seen in FIG. 9, fastener flange 74 is shorter in height than fastener flange 72, so as to accommodate the preferred hermetic seal arrangement shown in FIG. 10. The fastener flanges 72, 74 are heat sealed to panels 12, 14. With reference to FIGS. 4 and 10, fastener flange 72 is welded or otherwise mechanically sealed to panel 12 at weld band 78. As shown at the upper portion of FIG. 10, the upper ends of panels 12, 14 are joined to the outer outwardly facing surfaces of fastener flanges 72, 74 at points intermediate the fastener tracks and peelable seal 36. Band 36 preferably comprises an hermetic peelable seal formed by the joinder of panel 14 to the inside face 72a of fastener flange 72 (see FIGS. 10 and 10a). Panel 12 is sealed to the opposite outside face of the fastener flange as schematically indicated in FIG. 10. In FIG. 10a the components of the peelable seal 36 are shown, with film 12, which plays no part in the preferred peelable seal, being shown in phantom. Variations of the peelable seal are also contemplated by the present invention. For

-12-

example, in FIG. 10b, the flanges 72, 74 of the fastener arrangement are joined with a peelable seal. The upper ends of these flanges are heat sealed to panels 12, 14 as shown. In FIG. 10c a further alternative is shown with
5 the peelable seal 36 being formed at the joinder of lower portions of panels 12,14. the upper portions of panels 12, 14 are heat sealed to fastener flanges 72, 74.

As will now be appreciated, the enlarged, tapered end portions 80 of side seal 22 cooperate with
10 other features of flexible package 10 to provide a number of important advantages. More specifically, the enlarged tapered end portions 80 provide a smooth transition of the interior of flexible package 10 preventing product entrapment in the slider and fastener track surfaces when
15 product is poured or otherwise dispensed. In addition, the enlarged tapered portion 80 helps to secure slider 30 about tracks 26, 28 by maintaining a clearance from bottom surfaces 26a, 28a of the fastener tracks.

Further, the enlarged tapered portions 80 of side seals
20 22 strengthen and rigidify edge portions of panels 12, 14 in the immediate area of the parked position of slide 30.

Often, the greatest amount of force applied by the user to slider 30 occurs at the closing of the slider, when the fastener tracks are unlocked or
25 separated from one another. When the slider 30 is in the middle of its travel along the fastener tracks, the user is provided with a sensation of the proper direction of slider movement. However, when the slider 30 is in the parked position, and especially in the "parked open"
30 position shown in FIG. 1, the user's initial application of force may be misdirected. The enlarged tapered portion 80 provides added stiffness and rigidity to the flexible package at the initial point where pressure is applied to the slider, thus further contributing to the
35 assurance that secure engagement will be maintained between slider 30 and the tracks 26, 28.

With reference to FIG. 4, a consumer desiring to close the flexible package will grasp the enlarged

-13-

side seal portion 80, pulling in the direction of arrow 81 while pulling or pushing slider 30 in the direction of arrow 31. The added stiffness and rigidity offered by enlarged side seal portion 80 is provided at a point of optimal effectiveness to react in an appropriate manner to forces applied to slider 30 and to overcome any resistance of the tracks 24, 26 to resume a mating, interlocked condition as the fastener tracks are interlocked. Those skilled in the art will appreciate that the "rolling resistance" or dynamic resistance to movement of slider 30 is oftentimes lower than the initial static resistance, opposing movement of the slider away from the fully opened parked position shown, for example, in FIG. 4.

The added stiffness and rigidity imparted to the flexible package 10 and especially panels 12, 14 by enlarged side seal portion 80 results in other advantages when lightweight panels 12, 14 are employed. For example, panels of the single polyolefin type where no laminate film (such as PET or NYLON) is used to stiffen and support the support panel, have oftentimes excluded the use of sliding zippers, since minimum stiffness and rigidity needed to operate a fastener slider was not available. However, with enlarged side seal portions according to principles of the present invention, adequate stiffness is provided, even for lightweight, so-called "single" films.

As indicated in FIG. 10, flanges 72, 74 are joined to respective panels 12, 14, preferably at their lower ends, so as to prevent product from entering between flange 72 and panel 12, as well as between flange 74 and panel 14. In certain applications this may not be a critical requirement. In FIG. 10, the upper portion of panel 12 is shown for illustrative purposes as spaced from the lower end of flange 72. In practice, it is generally preferred that this spacing be eliminated, with panel 12 being in intimate contact with flange 72. Similarly, any gap between panel 14 and the lower end of

-14-

fastener flange 74 is preferably eliminated. Although it is most preferred that the peelable seal be formed by joining panel 14 to fastener flange 72, the peelable seal, preferably an hermetic seal, can be formed between the fastener flanges 72, 74 or directly between the panels 12, 14, although these alternative constructions are less preferred than the arrangement shown in FIG. 10.

Turning now to FIG. 13, flexible package 10 is shown constructed with the panels 12, 14, side seal 22, upper enlarged side seal portion 80 and fastener tracks 26, 28, as described above. The fastener tracks 26, 28 are preferably joined to flanges 72, 74 (not visible in FIG. 13). FIG. 13 schematically illustrates commercial fabrication of flexible package 10. As will be appreciated by those skilled in the art, practical commercial assembly requires recognition of tolerances of the equipment and materials used to construct a viable commercial product. For example, tracks 26, 28 are ultimately mechanically coupled to panels 12, 14 using conduction heat seal tooling. A gap 110 shown in FIG. 13 represents the tolerance range or margin of error for tool alignment used to secure the fastener tracks 26, 28. As mentioned, it is preferred that the upper end of enlarged side seal portion 80 be spaced below the lower ends of the fastener tracks, such as the lower end 26a of fastener track 26 visible in FIG. 13. Further, it is preferred that the gap g continue beyond the end 56 of slider 30.

A gap 116 represents a tolerance range or margin of error for the desired positioning of the upper end of enlarged side seal portion 80, to provide clearance for the bottom edge of slider 30. As illustrated in FIG. 13, the upper end of enlarged side seal portion 80 falls at an outermost limit of its tolerance range. Preferably, the upper end of enlarged side seal portion 80 is within the gap 116, rather than to one end thereof. The gap 116 also accounts for any cant or angular mis-positioning or mis-alignment where

-15-

the upper end of side seal 80 may be angled slightly from a position parallel to the fastener tracks, as may be encountered in a practical commercial environment.

A band 120 shown in FIG. 13 represents a
5 conduction heat seal of the fastener flange to the panels 12 or 14. This conduction heat seal 120 provides the principal mechanical attachment of the fastener track assembly to the package panels. Band 36 is the peelable seal, preferably an hermetic seal, between panel 14 and
10 fastener flange 72. A gap 124 represents the desired production spacing between production seal 120 and peelable seal 36. The remaining band 128 represents the production tolerance range or margin of error for positioning of peelable seal 36 with respect to the
15 package panels.

In one commercial embodiment, flexible package
10 comprises a plastic bag having a width of approximately 6.5 inches from side edge to side edge and a total overall height of approximately 10.75 inches. The
20 fastener tracks 26, 28 have a height of approximately 4 millimeters, with gaps 110, 116 each having a height of 2 millimeters. As shown in the upper right hand corner of FIG. 13, stop 68 projects a distance u above the top edge of the fastener tracks. In FIG. 13, only the top edge
25 26b is visible. With reference to FIG. 10, the upper ends of panels 12, 14 are preferably spaced a distance p from the bottom edges of the fastener tracks, ranging between 2 and 3 millimeters. The conduction heat seal 120 and the peelable seal 36 each have a height of 6
30 millimeters, and gap 124 located between the two, has a height of 2 millimeters. The desired spacing between conduction heat seal 120 and peelable seal 36 has a maximum value of 2 millimeters and a minimum value required to prevent overlap of the conduction heat seal
35 and peelable seal. The side seal 22 has a width ranging between 3 and 8 millimeters and the stop 68 has a width (see reference character d in FIG. 1) ranging between 2.0 and 8.0 mm. As can be seen with reference to FIG. 13,

-16-

the upper end of side seal 22 is spaced a substantial distance below the upper edge of the flexible package. This spacing ranges between a minimum value equal to the combined height of the fastener tracks and gap 110, and a maximum value equal to the combined height of the fastener tracks, gap 110 and gap 116.

Referring to FIG. 14, several alternative features are shown with reference to a flexible package 130. The right hand portion of flexible package 130 is identical to flexible package 10, described above, except for the addition of a peg hole 132 formed in the enlarged side seal portion 80. Flexible package 130 has a left side seal 20 as described above with respect to FIG. 1. However, in the flexible package 130, the upper end of side seal 20 is enlarged at 138 in a manner similar to that of enlarged side seal portion 80. An optional peg hole 140 is formed in the enlarged side seal portion 138. Although the peg holes 132, 140 are shown having a circular shape, virtually any shape (e.g., oval) can be used, as well. Peg holes 132, 140 can be formed by punching before or after the side seals are fully formed, it being preferred that the upper ends of the side seals provide a complete sealing of the panels and other components of the flexible package. It will be appreciated by those skilled in the art that the holes add heat relief to the enlarged side seal portion. This helps preserve the uniformity of the tapered area and of the dimensioning of gap g , as well as the uniformity of shrinkage which helps control manufacture on a production basis. If desired, the heat sealing die can be made hollow in the region of the peg holes, even in the absence of peg hole features to attain further heat relief advantages. It may also be preferable in some instances to form the peg holes 132, 140 as part of the formation of the side seals using, in effect, a thermal cutting or thermal punching technique. With the inclusion of two peg holes 132, 140, flexible package 130

-17-

can provide an improved presentation of art work or other indicia carried on the panels of the flexible package.

It is generally preferred that textual and graphic information be oriented generally perpendicular to the side edges of the flexible package. If only one peg hole is provided, the package will tend to hang rotated in a vertical plane, according to the distribution of product within the flexible package. With support given to two peg holes 132, 140, the flexible package is oriented in an upright position, making it easier to read the text and graphical information carried on the package. If desired, the text and graphical information printed on the rear panel can be inverted so that a consumer can "flip" the package to inspect the rear panel, without having to remove the package from the support pegs passing through peg holds 132, 140.

Although the package opening, fastener tracks and related features are shown at the upper end of the flexible package, the present invention is intended to cover arrangements in which the opening and related structure is provided on the side or bottom of the flexible package.

The drawings and the foregoing descriptions are not intended to represent the only forms of the invention in regard to the details of its construction and manner of operation. Changes in form and in the proportion of parts, as well as the substitution of equivalents, are contemplated as circumstances may suggest or render expedient; and although specific terms have been employed, they are intended in a generic and descriptive sense only and not for the purposes of limitation, the scope of the invention being delineated by the following claims.

-18-

WHAT IS CLAIMED IS:

1. A reclosable flexible package comprising:
opposed front and rear panels having sides and
joined together to form an interior and a package opening
5 communicating with said interior;

first and second interlockable fastener tracks
configurable in an interlocked, closed position and an
unlocked open position;

a slider movable along said fastener tracks to
10 configure said tracks in said interlocked position so as
to close said opening and to configure said fastener
tracks in said unlocked position so as to allow access
through said opening to said package interior;

said fastener tracks having opposed ends
15 located adjacent said opposed sides of said front and
said rear panels;

stops adjacent said ends of said fastener
tracks to interfere with and prevent travel of said
slider beyond said fastener tracks;

20 a side seal of pre-selected width joining
together one side of said front and said rear panels,
said side seal having an enlarged end portion of enlarged
width adjacent said fastener tracks, with at least a part
of said enlarged end portion disposed below said fastener
25 tracks; and

wherein said enlarged end portion is disposed
beneath the substantial entirety of said slider and
shields said slider, deflecting product being discharged
from said package interior, around said slider.

30 2. The reclosable flexible package of claim 1
further comprising a peelable seal preventing
communication of said opening with said package interior.

3. The reclosable flexible package of claim 2
wherein said peelable seal comprises an hermetic seal.

-19-

4. The reclosable flexible package of claim 1 wherein said enlarged end portion includes a double reverse curvature cooperating to define said package interior

5 5. The reclosable flexible package of claim 1 wherein said stops comprise deformed end portions of said fastener track.

6. The reclosable flexible package of claim 5 wherein said fastener track end portions are softened
10 with application of ultrasonically generated heat and deformed.

7. The reclosable flexible package of claim 6 wherein the bottoms of said fastener tracks are preserved undeformed.

15 8. The reclosable flexible package of claim 5 wherein said fastener tracks are deformed by flattening to form surfaces extending generally parallel to said front and said rear panels.

9. The reclosable flexible package of claim 1
20 further comprising flanges extending from said fastener tracks and joined to said front and said rear panels.

10. The reclosable flexible package of claim 9 further comprising a sealing band between said fastener tracks and said peelable seal joining said flanges to
25 said front and said rear panels.

11. The reclosable flexible package of claim 1 wherein said fastener tracks have a bottom portion engaging said slider so as to prevent disengagement of said slider from said fastener tracks.

-20-

12. The reclosable flexible package of claim 11 wherein said bottom portions of said fastener tracks are spaced from said side seal

13. The reclosable flexible package of claim 1 wherein said enlarged end portion defines a hole for hanging support of said reclosable flexible package.

14. The reclosable flexible package of claim 1 wherein both of said side seals have a pre-selected width and an enlarged end portion of enlarged width adjacent said fastener tracks, with at least a part of said enlarged end portion disposed below and spaced from said fastener tracks.

15. A reclosable flexible package comprising:
a slider of predetermined width;
opposed front and rear panels having sides and joined together with side seals of preselected width less than the predetermined width of said slider, to form an interior and a package opening communicating with said interior;

first and second interlockable fastener tracks configurable in an interlocked closed position and an unlocked open position;

said slider movable along said fastener tracks to configure said tracks in said interlocked position so as to close said opening and to configure said fastener tracks in said unlocked position so as to allow access through said opening to said package interior;

said fastener tracks having opposed ends located adjacent said opposed sides of said front and said rear panels;

stops adjacent said ends of said fastener tracks to interfere with and prevent travel of said slider beyond said fastener tracks; and

-21-

at least one said stop having a width less than the preselected width of said side seals and an upper portion projecting beyond said fastener tracks.

16. The reclosable flexible package of claim 5 15 wherein said fastener tracks have a bottom portion engaging said slider so as to prevent disengagement of said slider from said fastener tracks.

17. The reclosable flexible package of claim 16 wherein said bottom portions of said fastener tracks 10 are spaced from said side seal

18. The reclosable flexible package of claim 15 wherein one of said side seals has a pre-selected width and an enlarged end portion of enlarged width adjacent said fastener tracks, with at least a part of 15 said enlarged end portion disposed below and spaced from said fastener tracks;

19. The reclosable flexible package of claim 18 wherein said enlarged end portion is disposed beneath the substantial entirety of said slider and shields said 20 slider, deflecting product being discharged from said package interior, around said slider.

20. The reclosable flexible package of claim 18 wherein said enlarged end portion defines a hole for hanging support of said reclosable flexible package.

25 21. The reclosable flexible package of claim 15 further comprising a peelable seal preventing communication of said opening with said package interior.

22. The reclosable flexible package of claim 21 wherein said peelable seal comprises an hermetic seal.

-22-

23. The reclosable flexible package of claim 18 wherein said enlarged end portion includes a double reverse curvature cooperating to define said package interior.

5 24. The reclosable flexible package of claim 15 wherein both of said side seals have a pre-selected width and an enlarged end portion of enlarged width adjacent said fastener tracks, with at least a part of said enlarged end portion disposed below and spaced from
10 said fastener tracks.

 25. A reclosable flexible package comprising:
 opposed front and rear panels having sides and joined together with side seals to form an interior and a package opening communicating with said interior;

15 at least one said side seal having a preselected width and an enlarged end portion of enlarged width adjacent said fastener tracks, with at least a part of said enlarged end portion disposed below said fastener tracks;

20 first and second interlockable fastener tracks having opposed ends and configurable in interlocked closed position and an unlocked open position;

 a slider movable along said fastener tracks to configure said tracks in said interlocked position so as
25 to close said opening and to configure said fastener tracks in said unlocked position so as to allow access through said opening to said package interior;

 stops adjacent said ends of said fastener tracks to interfere with and prevent travel of said
30 slider beyond said fastener tracks;

 flanges extending from said fastener tracks;

 a sealing band coextensive with and spaced from said fastener tracks, joining said front and said rear panels to respective ones of said flanges; and

-23-

a peelable seal coextensive with and spaced from said sealing band, preventing communication of said opening with said package interior.

26. The reclosable flexible package of claim 5 25 wherein said peelable seal comprises an hermetic seal.

27. The reclosable flexible package of claim 25 wherein said fastener tracks have a bottom portion engaging said slider so as to prevent disengagement of said slider from said fastener tracks.

10 28. The reclosable flexible package of claim 27 wherein said bottom portions of said fastener tracks are spaced from said side seal

15 29. The reclosable flexible package of claim 25 wherein said enlarged end portion is disposed beneath the substantial entirety of said slider and shields said slider, deflecting product being discharged from said package interior, around said slider.

20 30. The reclosable flexible package of claim 25 wherein said enlarged end portion defines a hole for hanging support of said reclosable flexible package.

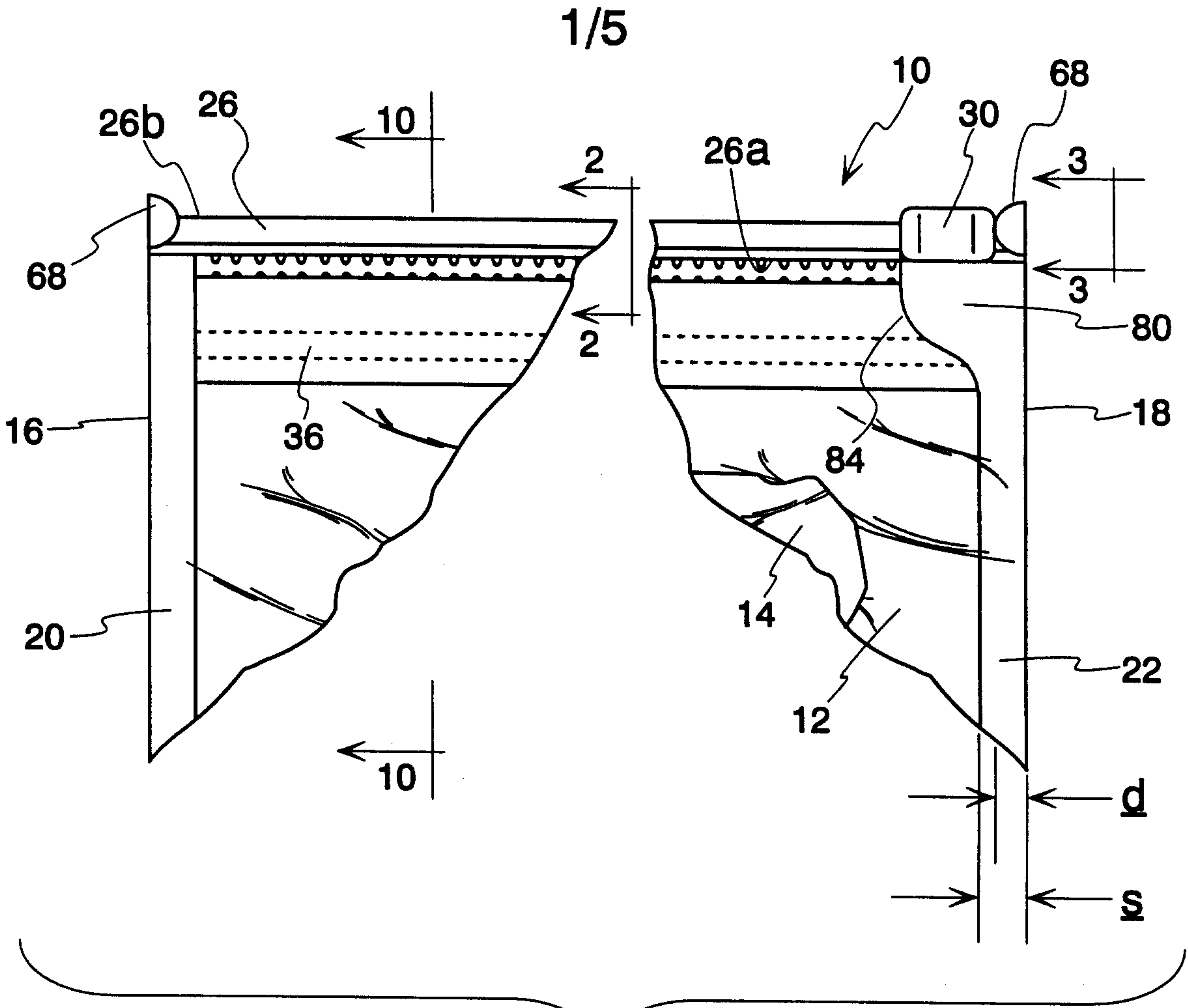

Fig. 1

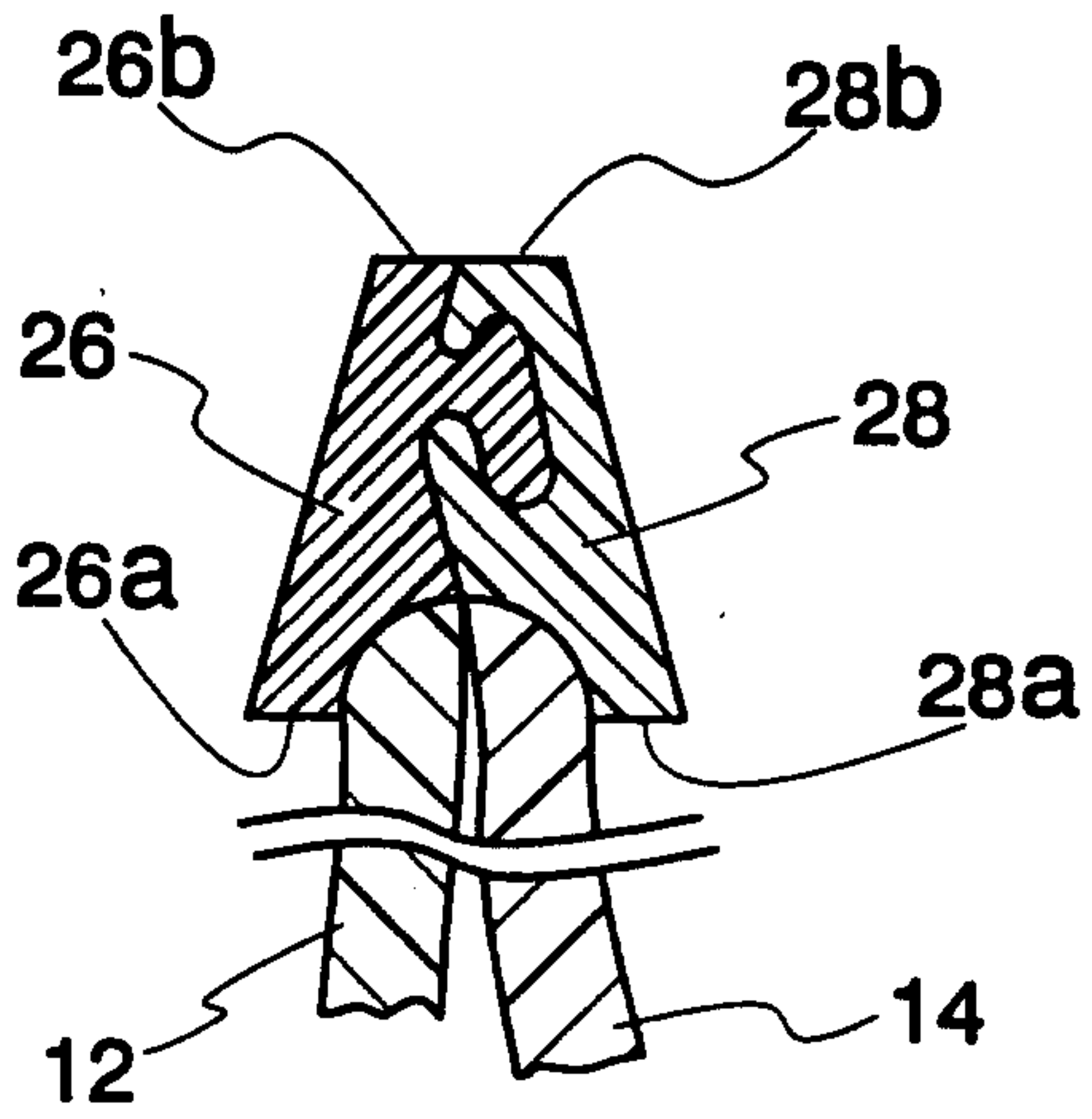

Fig. 2

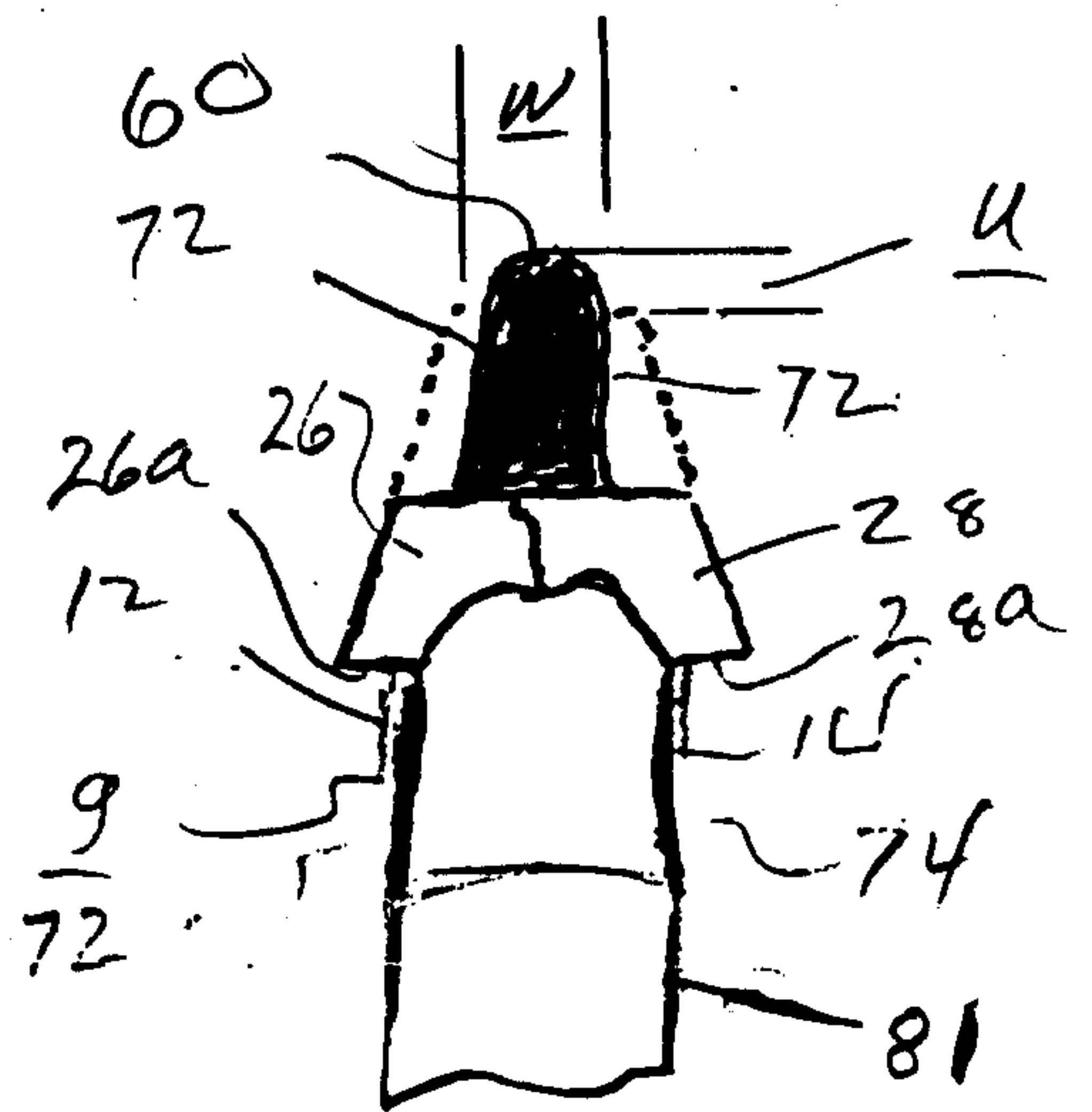

Fig. 3

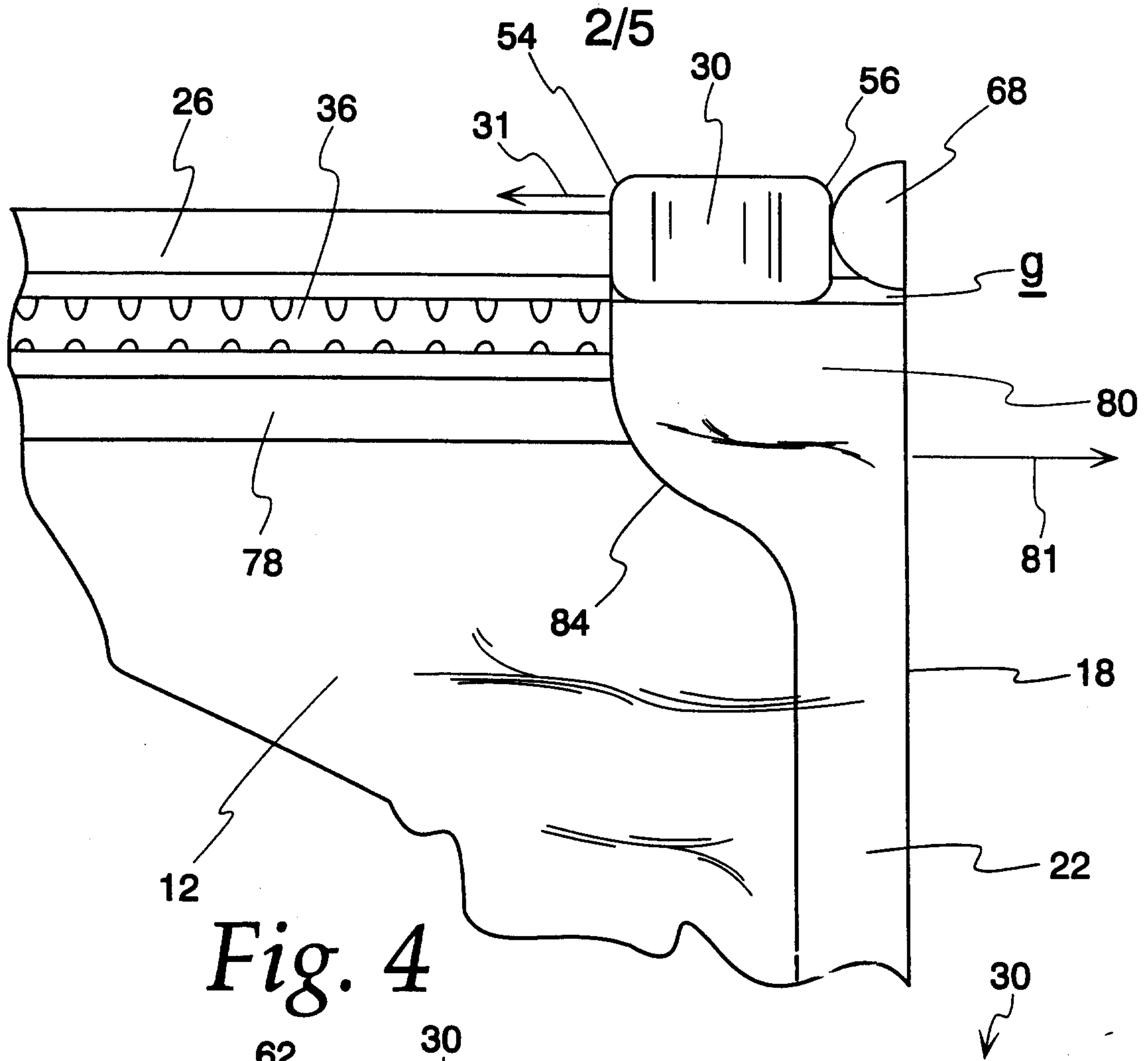

Fig. 4

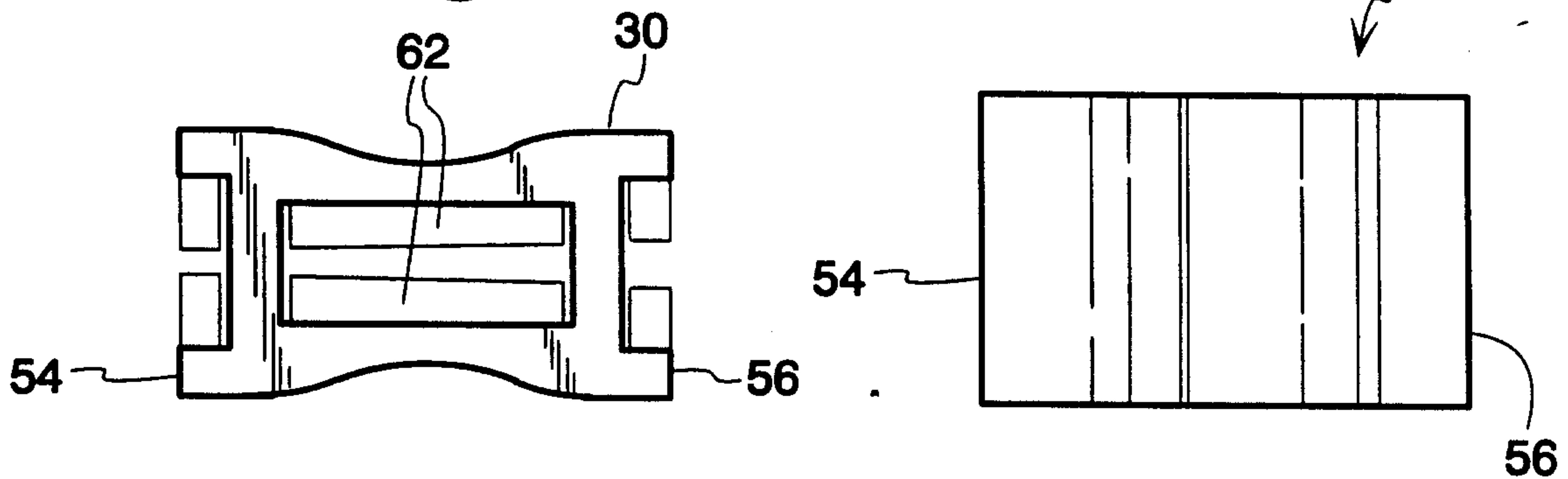

Fig. 5

Fig. 6

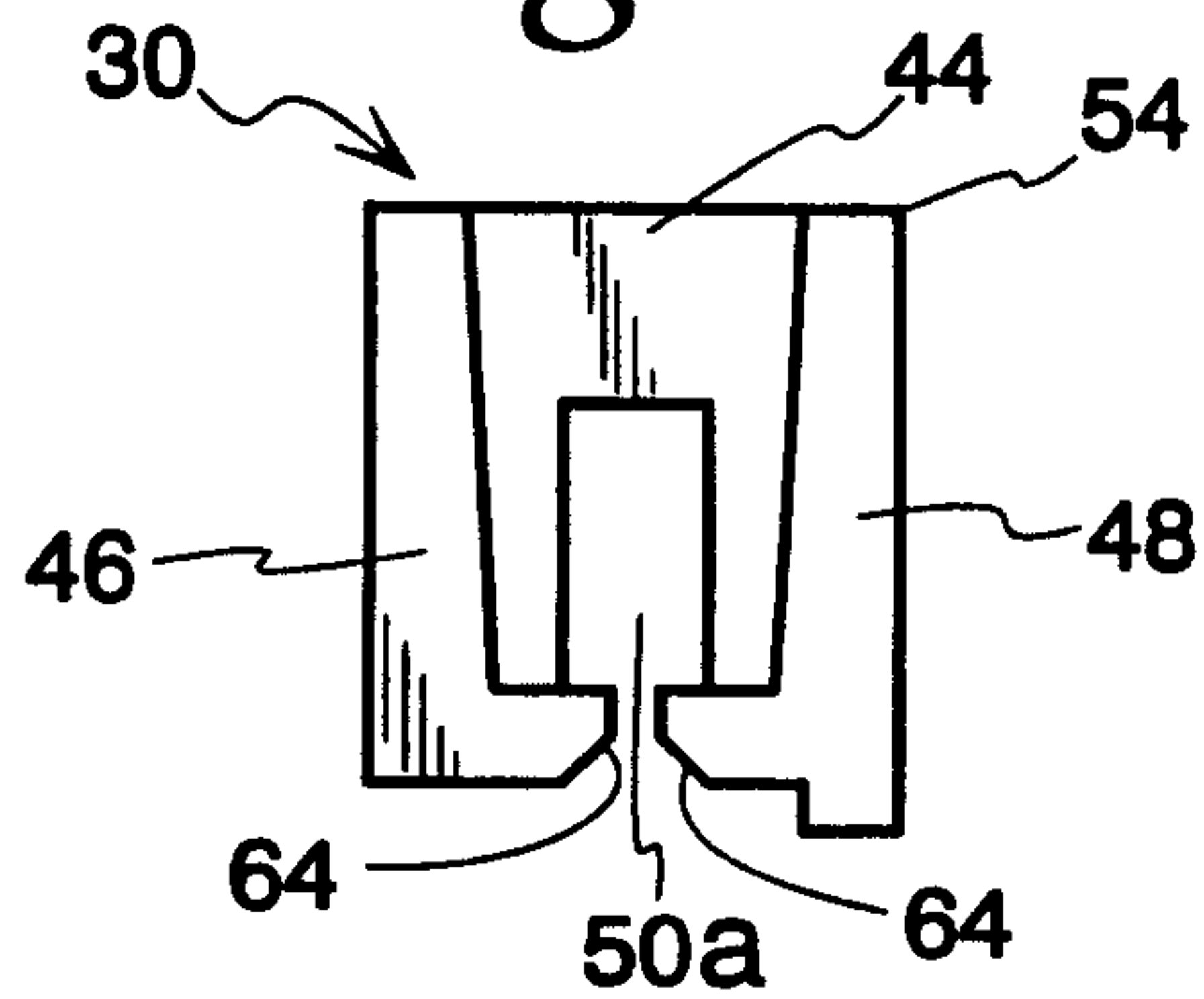

Fig. 7

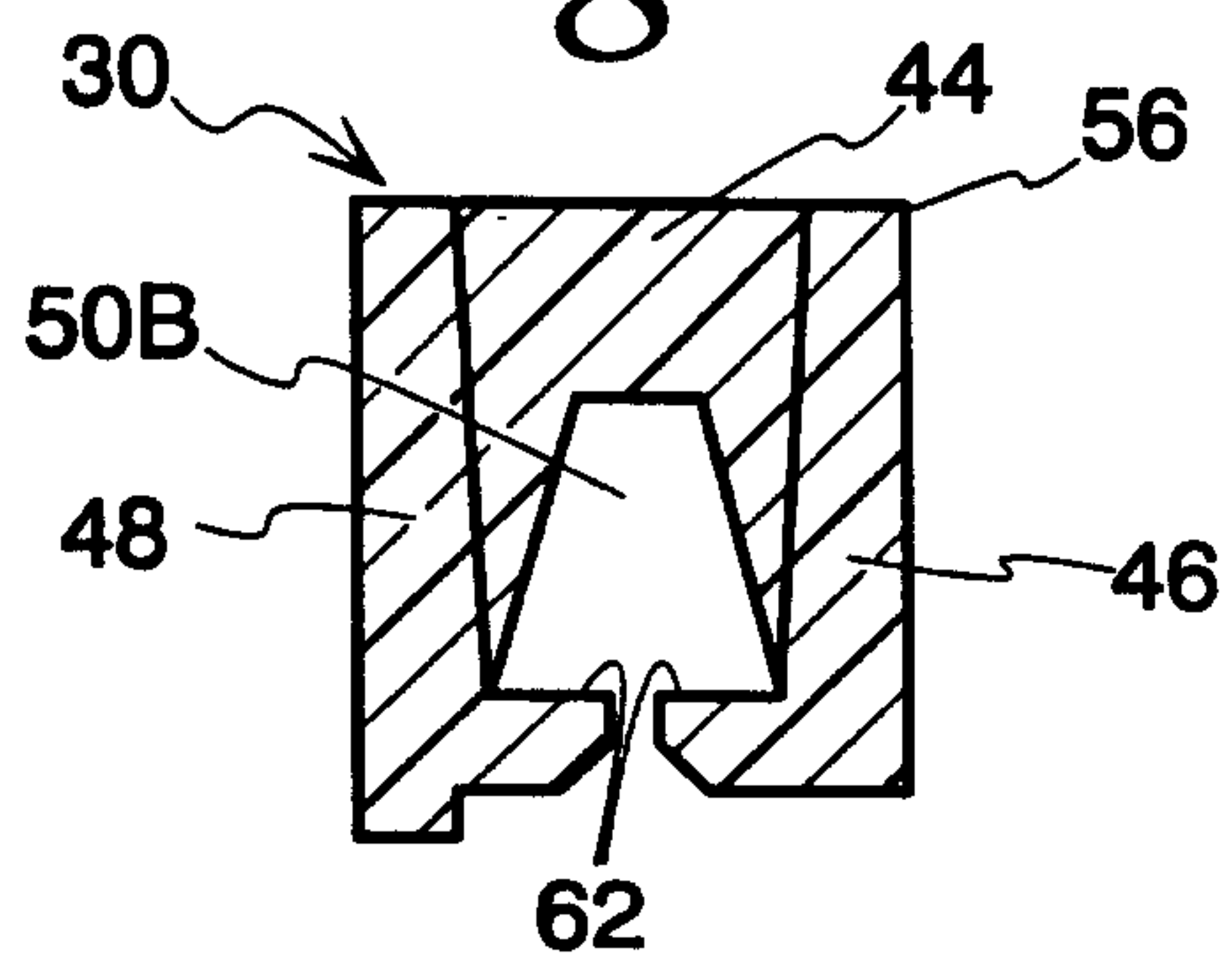

Fig. 8

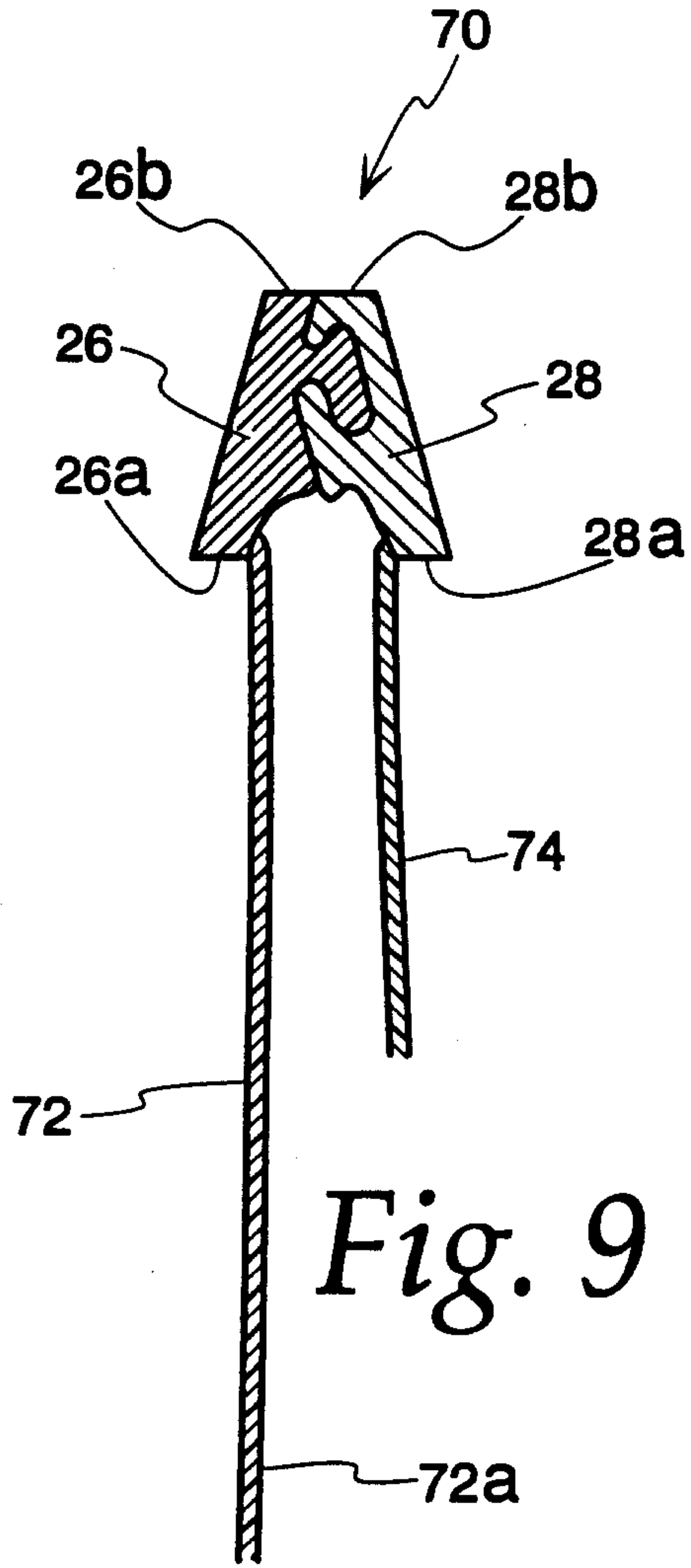

Fig. 9

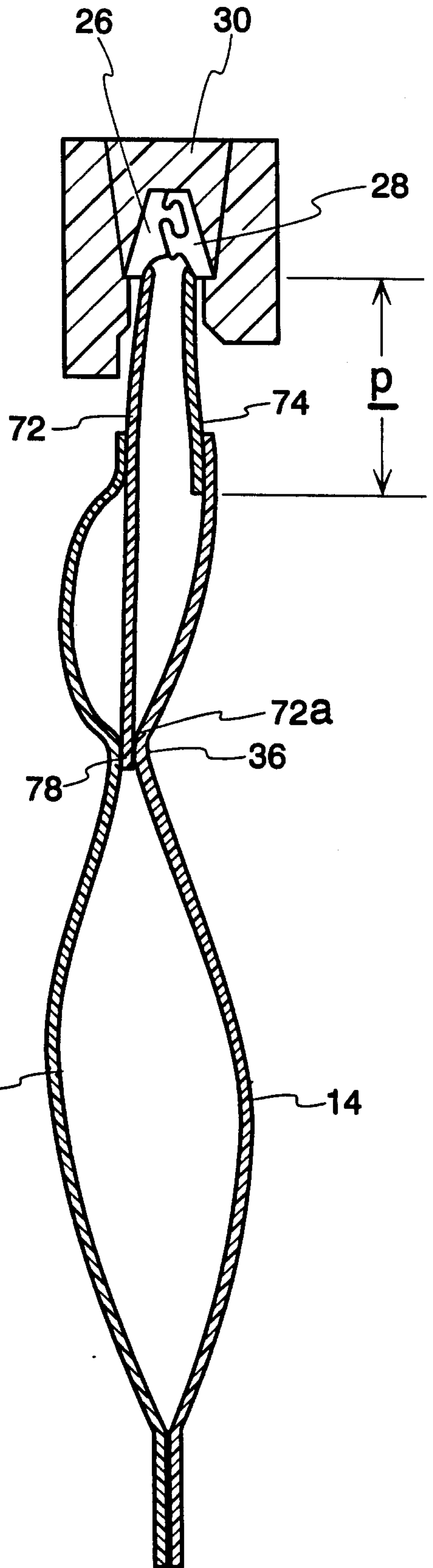

Fig. 10

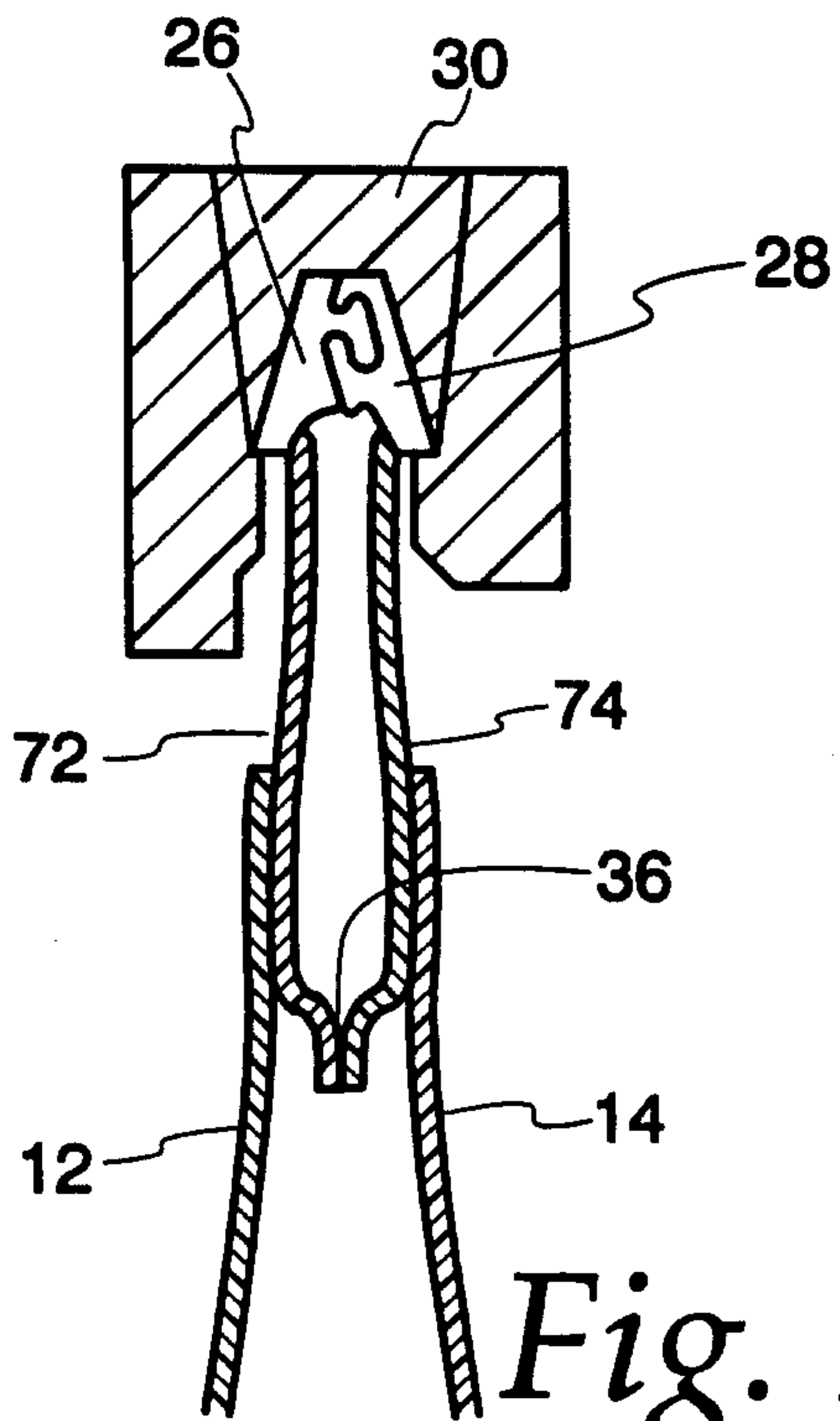

Fig. 10b

4/5

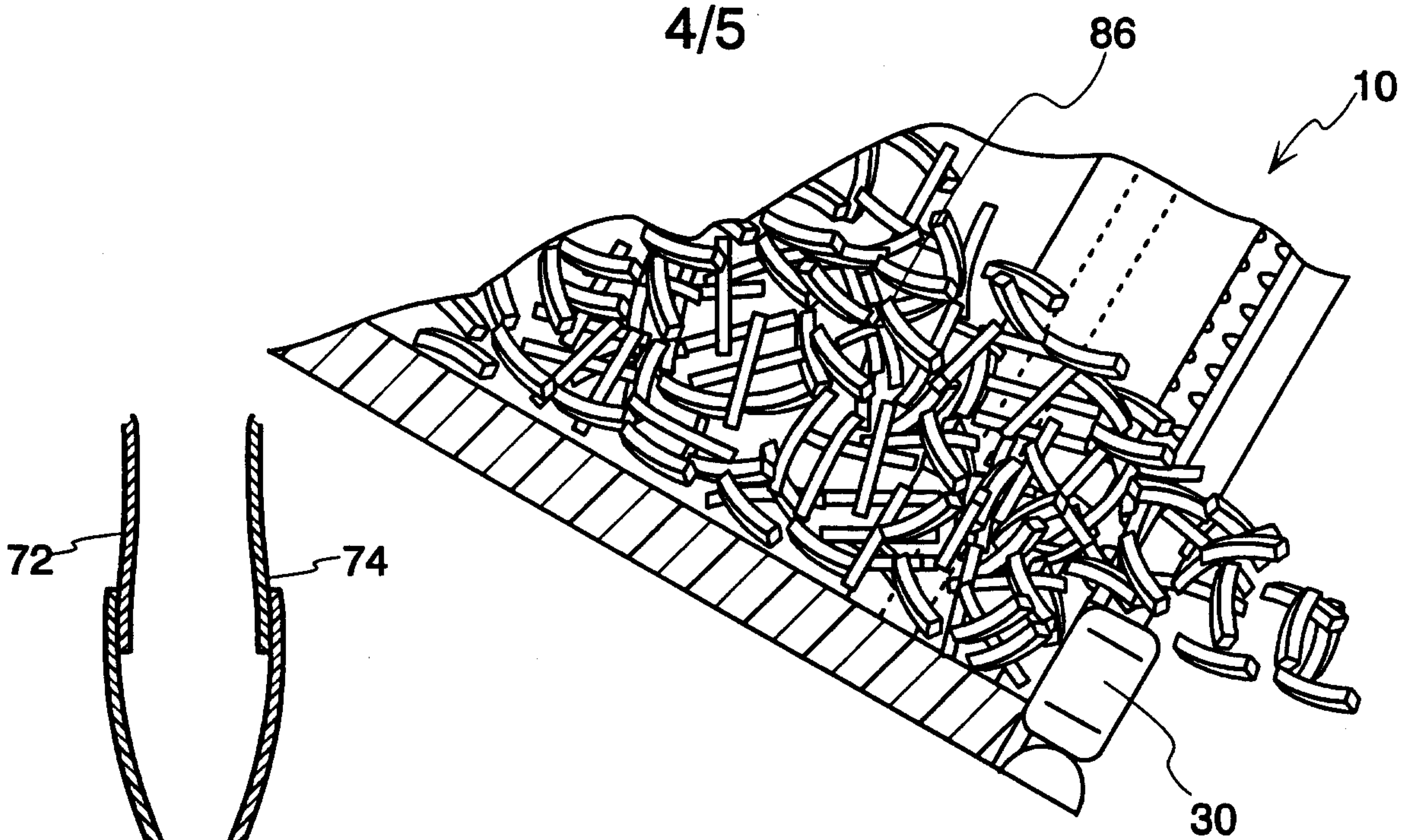

Fig. 10c

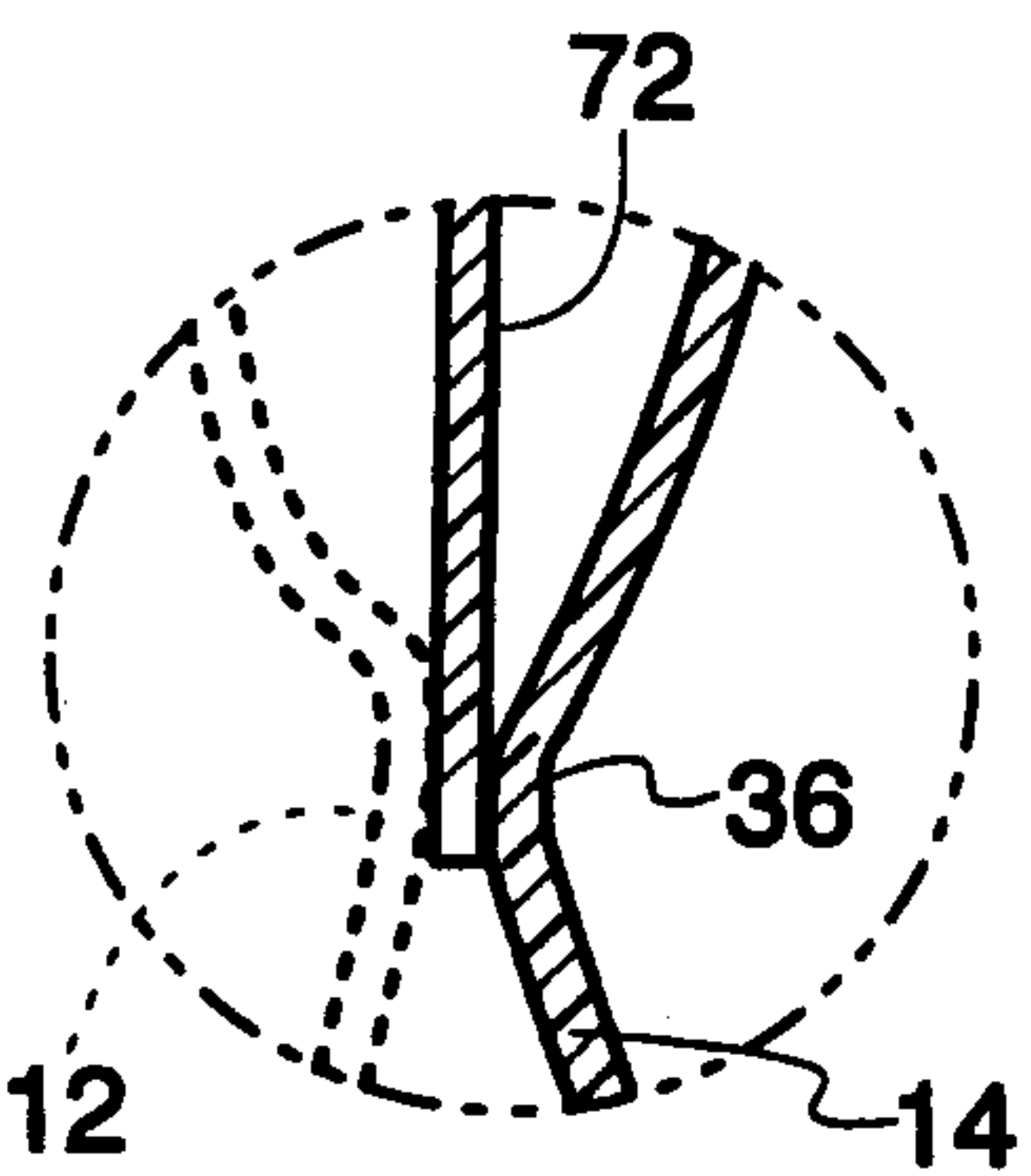

Fig. 10a

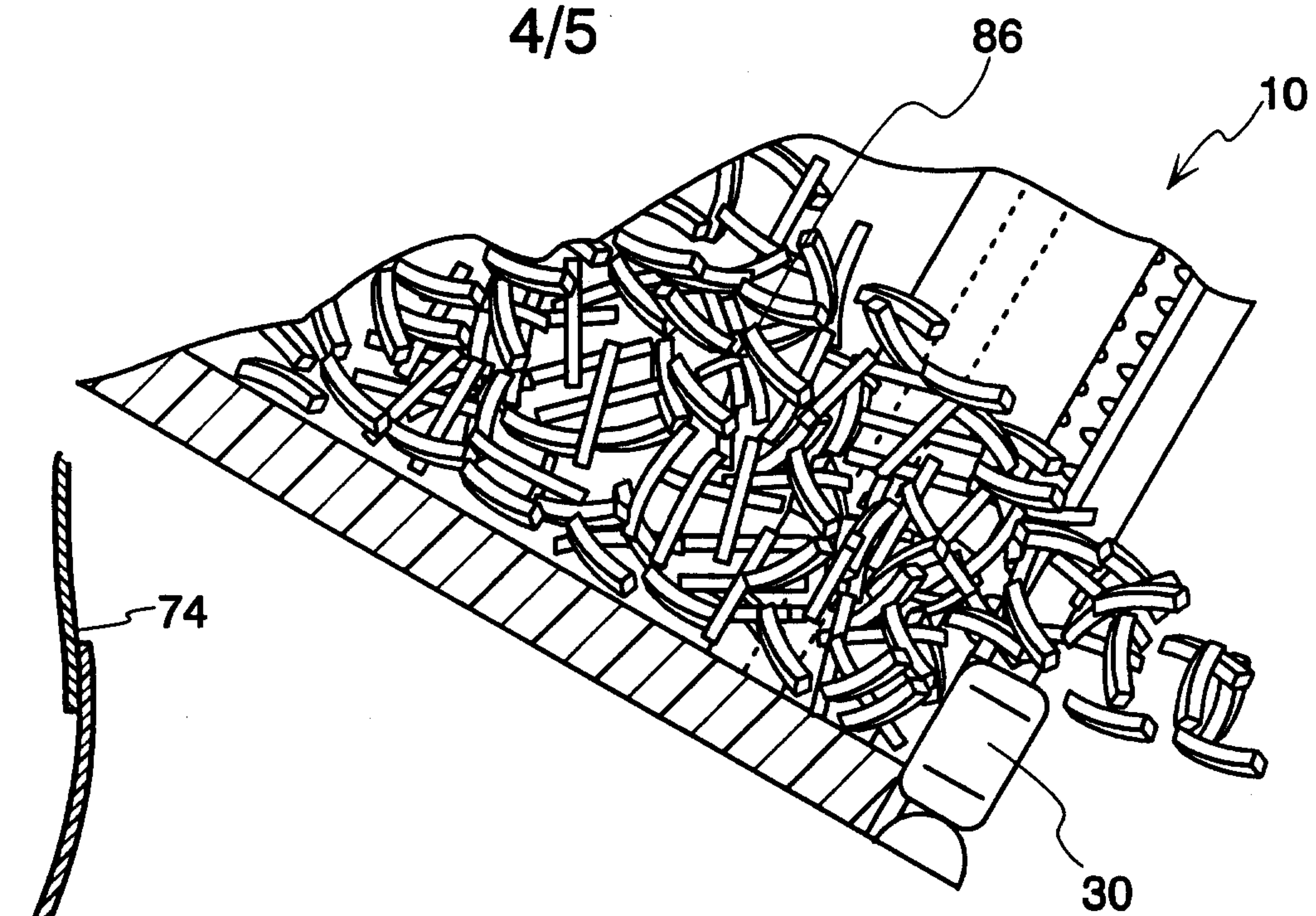
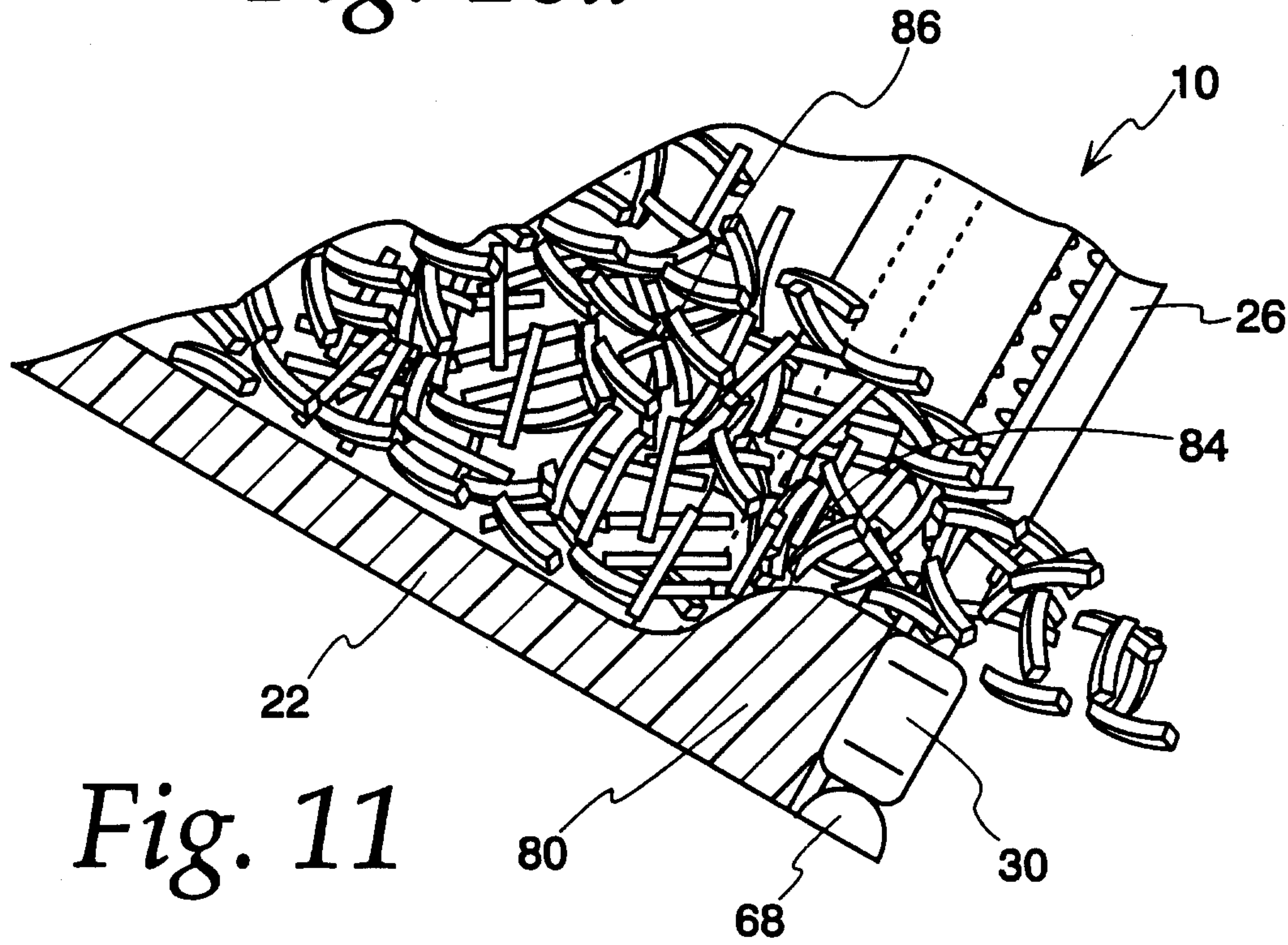

Fig. 11

Fig. 12
Prior Art



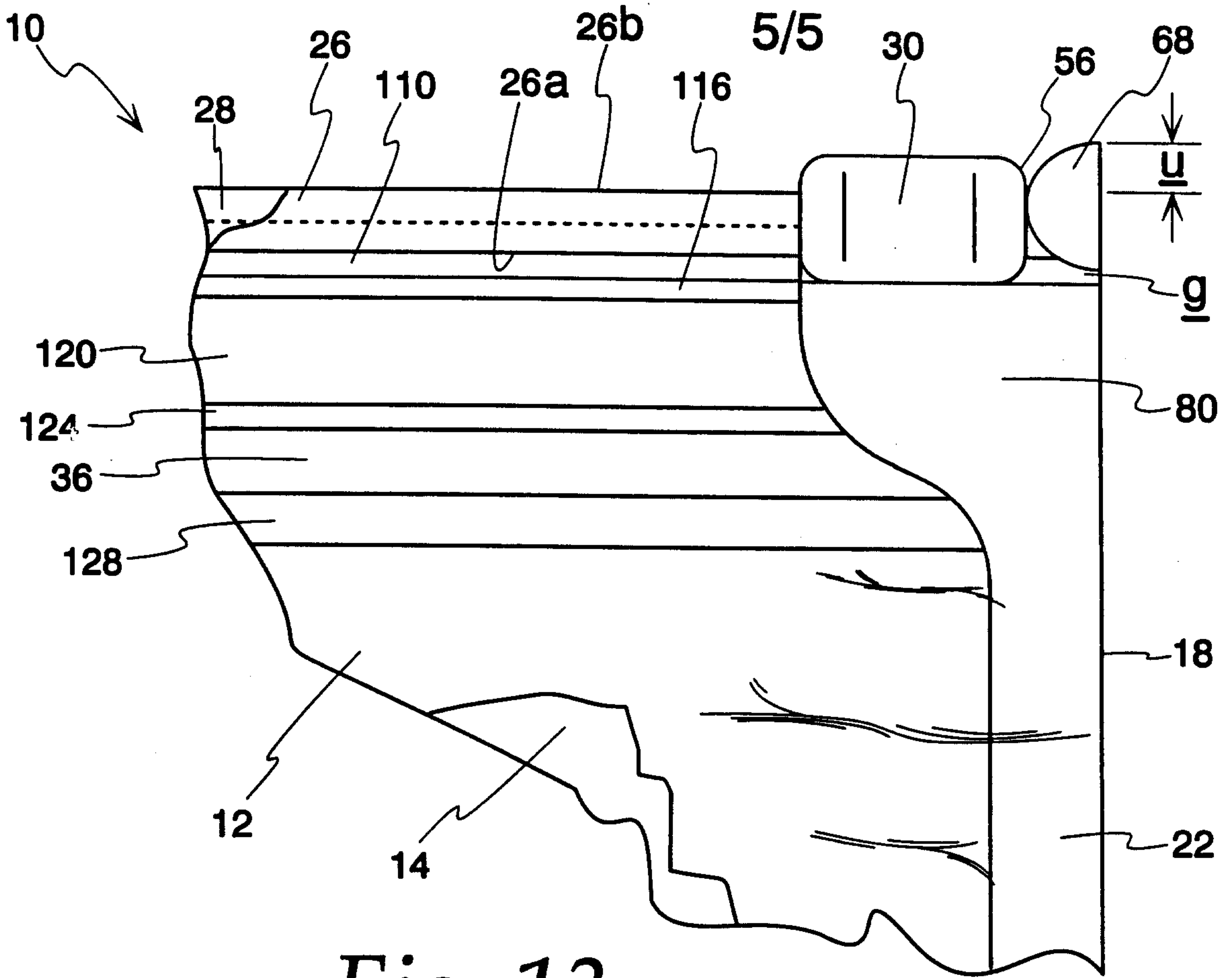

Fig. 13

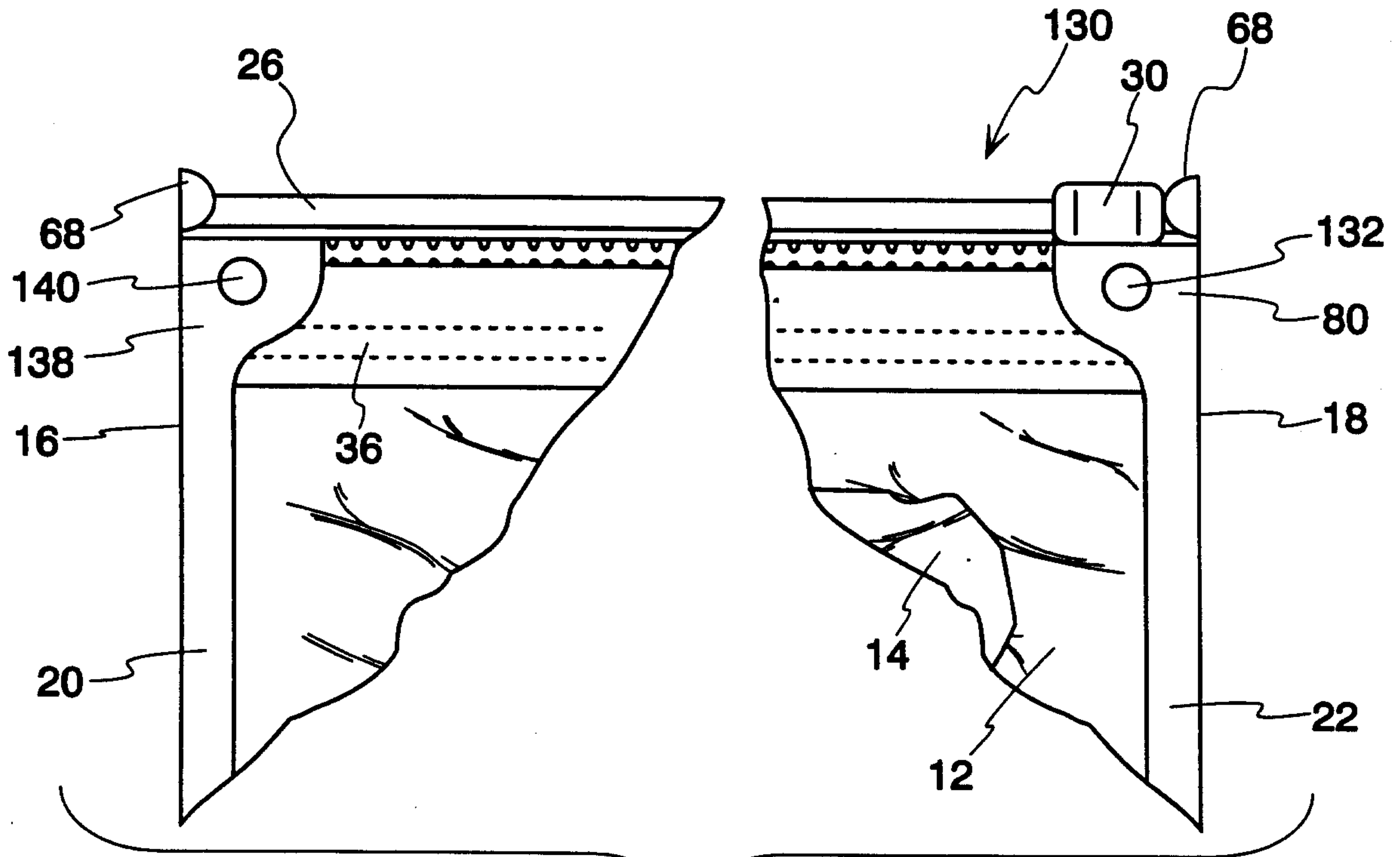

Fig. 14

