



(43) International Publication Date  
15 November 2012 (15.11.2012)

- (51) International Patent Classification:  
*E04B 1/24* (2006.01)      *E04B 2/56* (2006.01)  
*E04B 1/28* (2006.01)      *E04B 2/62* (2006.01)
- (21) International Application Number: PCT/SE2012/050467
- (22) International Filing Date: 4 May 2012 (04.05.2012)
- (25) Filing Language: English
- (26) Publication Language: English
- (30) Priority Data: 1150401-6      6 May 2011 (06.05.2011)      SE
- (71) Applicant (*for all designated States except US*): **MAKAHPER AB** [SE/SE]; Storgatan 23, S-272 31 Simrishamn (SE).
- (72) Inventors; and  
(75) Inventors/Applicants (*for US only*): **KALNINS, Aida** [SE/SE]; Replagaregatan 4 C, S-211 21 Malmö (SE).  
**Mårtensson, Håkan** [SE/SE]; Hamngatan 21, S-272 31 Simrishamn (SE).
- (74) Agent: **STRÖM & GULLIKSSON AB**; P.O. Box 4188, S-203 13 Malmö (SE).
- (81) Designated States (*unless otherwise indicated, for every kind of national protection available*): AE, AG, AL, AM, AO, AT, AU, AZ, BA, BB, BG, BH, BR, BW, BY, BZ, CA, CH, CL, CN, CO, CR, CU, CZ, DE, DK, DM, DO, DZ, EC, EE, EG, ES, FI, GB, GD, GE, GH, GM, GT, HN,

[Continued on next page]

(54) Title: SYSTEM OF ELEMENTS WITH COLUMNS, CROSS BEAMS AND COLUMN FITTINGS WITH CLIPS

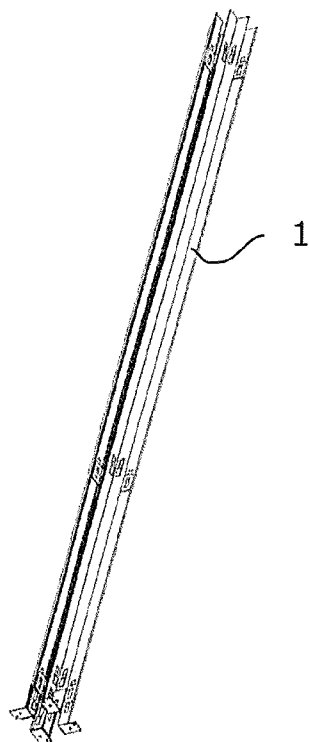

Fig. 1

(57) Abstract: The present invention concerns a system of building elements to form different erect constructions. The system comprises columns and cross beams (24). The columns are formed of two or four elongated L-plates (1). Each L-plate (1) has two elongated parts arranged mutually perpendicular. The L-plates (1) of each column are connected to each other by means of column fittings (3, 7, 11).





HR, HU, ID, IL, IN, IS, JP, KE, KG, KM, KN, KP, KR, KZ, LA, LC, LK, LR, LS, LT, LU, LY, MA, MD, ME, MG, MK, MN, MW, MX, MY, MZ, NA, NG, NI, NO, NZ, OM, PE, PG, PH, PL, PT, QA, RO, RS, RU, RW, SC, SD, SE, SG, SK, SL, SM, ST, SV, SY, TH, TJ, TM, TN, TR, TT, TZ, UA, UG, US, UZ, VC, VN, ZA, ZM, ZW.

UG, ZM, ZW), Eurasian (AM, AZ, BY, KG, KZ, RU, TJ, TM), European (AL, AT, BE, BG, CH, CY, CZ, DE, DK, EE, ES, FI, FR, GB, GR, HR, HU, IE, IS, IT, LT, LU, LV, MC, MK, MT, NL, NO, PL, PT, RO, RS, SE, SI, SK, SM, TR), OAPI (BF, BJ, CF, CG, CI, CM, GA, GN, GQ, GW, ML, MR, NE, SN, TD, TG).

**(84) Designated States** (unless otherwise indicated, for every kind of regional protection available): ARIPO (BW, GH, GM, KE, LR, LS, MW, MZ, NA, RW, SD, SL, SZ, TZ,

**Published:**

— with international search report (Art. 21(3))

System of elements with columns, cross beams and column fittings with clips.

5

#### Technical Field

The present invention concerns a system of building elements to form different erect constructions. The erect constructions may be fences, pergolas, tents, summerhouses, greenhouses etc. for use outdoors, or may be bookshelves, shop fittings etc for use indoors.

10

#### Prior Art

It is previously known to use columns, crossbeams, fittings etc. to form different erect constructions. With the expression "erect constructions" as used in the present description is meant fences, pergolas, tents, summerhouses, greenhouses, bookshelves, shop fittings etc.

15

The columns of previously known constructions often have major wooden parts, which wooden parts are subject to dimension changes due to varying humidity. Such dimension changes may lead to that formed constructions will become skewed or that the parts will be difficult to connect to each other in a proper way.

20

Some known systems for forming erect constructions have pre-fabricated wall sections or the like. Such pre-fabricated sections will take space both in storing and transportation.

25

#### Summary

In view of the above there is a need for a system for forming erect constructions, in which the risk of skewed constructions is reduced.

It is also beneficial if the constructions may be formed and erected manually without the need of any special tools. A further object is that it should be possible to form many different types of constructions using only a limited number of different elements.

30

Furthermore the space needed for storing and transportation should be kept at a minimum.

The above is achieved by means of a system of elements to form different erect constructions. The system comprises columns and cross beams, which columns are

35

formed of two or four elongated L-plates. The L-plates have each two elongated parts arranged mutually perpendicular.

The L-plates of the column are held together by means of column fittings. The column fittings have clips received in openings of the L-plate.

5 According to one aspect the L-plates are made of metal or plastic. In some embodiments the columns are provided with espalier rails to receive a large number of espalier beams.

Further objects and advantages of the present invention will be obvious to a person skilled in the art reading the detailed description below of different embodi-  
10 ments.

#### Brief Description of the Drawings

The present invention will be described further below by way of example and with reference to the enclosed drawings. In the drawings:

15 Fig. 1 is a perspective view of a column according to the present invention;

Fig. 2 is a side view of one part of the column of Fig. 1;

Fig. 3 is a side view of the column of Fig. 1;

Fig. 4 is a perspective view of a first column fitting, being part of the column of Figs. 1 and 3;

20 Fig. 5 is a perspective view of a second column fitting, being part of the column of Figs. 1 and 3,

Fig. 6 is a perspective view of a node formed of the fittings of Figs. 4 and 5;

Fig. 7 is a perspective view of an alternative embodiment of the second column fitting of Fig. 5;

25 Fig. 8 is a perspective view of a footing that may be used with the column of Figs. 1 and 3;

Fig. 9 is a side view of a column according to Figs. 1 and 3 fitted with an additional espalier rail;

Fig. 10 is a perspective view of an upper part of an espalier rail;

30 Fig. 11a is a perspective view of an espalier beam that may be used with the column of Fig. 9;

Fig. 11b is a perspective view of a cross beam that may be used with the column of Figs. 1, 3 or 9;

35 Fig. 11c is a perspective view of a cover beam that may be used with the column of Figs. 1, 3 or 9; and

Figs. 12-15 are side views of different constructions formed with parts of the present invention.

#### Detailed Description of Embodiments

5 As used in this description the expressions "vertical", "horizontal" and similar expressions are in view of the drawings referred to and at normal use of the different parts of the invention.

The column shown in Fig. 1 is formed of four elongated L-plates 1. The L-plates 1 are normally made of a suitable metallic or plastic material. As seen in cross  
10 section each L-plate 1 has two elongated parts arranged at right angles to each other. Between the two elongated parts of each L-plate 1 an elongated apex is formed. In a column formed of four elongated L-plates 1, the apex of each L-plate is directed towards the centre of the formed column. Each elongated part of each L-plate 1 has normally four openings 2. One opening 2 of each part of each L-plate 1 is placed at an up-  
15 per end of the L-plate 1. Two openings 2 are placed above each other at a lower end of the L-plate 1. The fourth opening 2 is placed somewhere between the upper and lower openings 2, normally closer to the lower end than the upper end of the column.

To form the column the four L-plates 1 are held together by means of column fittings 3, 7. There are two slightly different types of column fittings 3, 7 used to hold-  
20 ing the L-plates 1 together. A first type of column fitting 3 has a generally rectangular plate form. Two grooves 4 are arranged going from one edge of the column fitting 3, perpendicular to the edge. Each groove 4 ends about in the middle of the column fitting 3. Two clips 5 are arranged on one side of the column fitting 3, which clips 5 are placed outside the grooves 4. About in the middle of each column fitting 3 a through slit 6 is  
25 arranged, which slit 6 is arranged perpendicular to the grooves 4. The slit 6 is placed in the area between the grooves 4. In use the first type of column fitting 3 is to be placed with the grooves 4 open upwards. To accomplish this, the clips 5 are open downwards, as will explained further below. The second type of column fitting 7 only differs from the first type of column fitting 3, in the orientation of the grooves 8. Thus, the second  
30 type of column fitting 7 has two grooves 8 and a through slit 9. The grooves 8 go from one edge of the column fitting 7 to about the middle of the column fitting 7. The slit 9 is placed in the area between the grooves 8 and the grooves 8 and the slit 9 are arranged perpendicularly to each other. The second type of column fitting 7 has a generally rectangular plate form. In use the second type of column fitting 7 is to be placed with the

grooves 8 open downwards. Therefore, the clips 10 of the second type of column fitting 7 open downwards.

In an alternative embodiment the second type of column fittings described above is replaced by a third type of column fitting 11. The main difference to the earlier  
5 described column fittings is that the third type of column fitting 11 has no clips. The third type of column fitting 11 has a generally rectangular plate form. It has two grooves 12 and a through slit 13. The grooves 12 and slit 13 of the third type of column fitting 11 have the same mutual placement and orientation as for the grooves 8 and slit 9 of the second type of column fitting 7 described above.

10 In use and as shown in Fig. 6 two column fittings 3 of the first type and two column fittings 7 of the second type co-operate to form a node. As indicated in Fig. 6 the two column fittings 3 of the first type are placed parallel to each other and at a distance from each other. In the same way the two column fittings 7 of the second type are placed parallel to each other and at a distance from each other. The column fittings 3 of  
15 the first type are placed with the openings of the grooves 4 facing upwards. The mutual placement of the column fittings 3, 7 is established in that the grooves 8 of each column fitting 7 of the second type are received in one groove 4 of each column fitting 3 of the first type in a node.

Each clip 5 of the first type of column fitting 3 and each clip 10 of the second  
20 type of column fitting 7 is to be received in one of the openings 2 of the L-plates 1. For each node, such as the one indicated in Fig. 6, each L-plate 1 is attached with one elongated part to one clip 5 of the first type column fittings 3 and with the other elongated part to one clip 10 of the second type of column fitting 7. For each column there are normally three nodes formed. Of the three nodes one is placed at the upper openings 2  
25 of the L-plates 1, one is placed at the upper openings 2 of the two lower openings 2 and one node is placed at the openings 2 of the L-plate 1 placed between the upper and lower openings 2.

If the third type of column fittings 11 replaces the second type of column fittings 7, each L-plate 1 will only be connected to one column fitting 3 of the first type at  
30 each node. The connection being that one clip 5 of each column fitting 3 of the first type is received in one opening 2 of the L-plate 1.

In some embodiments columns formed of only two L-plates 1 are used. To form columns using only two L-plates 1, only column fittings 3 of the first type are normally used.

A footing 14 is placed at the bottom of each L-plate 1. Each footing 14 has a vertical part 15 and a horizontal part 16, which vertical part 15 and horizontal part 16 are mutually perpendicular. A clip 17 is arranged on the vertical part 15, which clip 17 is to be received in the lowermost opening of each L-plate 1. In use the horizontal part  
5 16 of the footing 14 will be placed on the ground, the floor or a possible support. To fasten the footing 14 to the ground, the floor or a support the horizontal part 16 has through openings 18 to receive fastening means, such as screws, bolts or nails.

In some embodiments the columns are provided with an espalier rail 19 each. The term espalier rail 19 is used, as the espalier rail 19 has been developed for use when  
10 forming espaliers, but it may of course be used for other types of constructions as well. Each espalier rail 19 has a number of openings 20 placed in line with one another and at a distance from each other. At an upper end of each espalier rail 19 there is a horizontal part 21 being perpendicular to the rest of the espalier rail 19. The horizontal part 21 is to be received in the slit 6, 9, 13 in one of the column fittings 3, 7, 11 of either type,  
15 whereby the espalier rail 19 is connected to the column. The espalier rail 19 will be placed in the area between two L-plates 1 of the formed column. The number of openings 21 of the espalier rails 19 and there mutual distance may be varied depending on intended use. In the openings 21 of the espalier rails 19 espalier beams 22 forming the espalier are normally to be received. The espalier beams 22 have a beam clip 23 at each  
20 end, which beam clips 23 are to be received in the openings 21 of the espalier rails 19.

To form different erect constructions, cross beams 24 are placed between two columns formed of the L-plates 1. The cross beams 24 have a beam clip 23 at each end, which beams clips 23 are to be received on the column fittings 3, 7, 11. The end of each cross beam 24 is placed between two L-plates 1 of a respective column.

25 In some cases a cover beam 25 is used. The cover beam 25 is to be placed on top of an espalier beam 22 or a cross beam 24. The cover beam 25 has a protruding end 26 at each end. The protruding ends 26 are narrower than the rest of the cover beam 25 and the narrower protruding ends 26 are to be received in the area between two L-plates 1 in a column formed.

30 By the use of the system of the present invention many different types of erect constructions may be formed. In Figs. 12-15 some examples of such constructions are indicated. The part of Fig. 12 may be used as a part of a pergola or a fence. To stabilize the part of Fig. 12 two diagonally placed struts are used. In Figs. 13 and 14 examples of espaliers are shown, in which espalier rails 19 are used. In Fig. 15 one example of a

wall of a small building is shown. For a building such as the one indicated in Fig. 15 the parts described above may be supplemented with boards, doors, windows etc.

## CLAIMS

1. A system of elements to form different erect constructions, comprising columns and cross beams (24), wherein the columns are formed of two or four elongated L-plates (1), each having two elongated parts arranged mutually perpendicular and  
5 wherein the L-plates (1) of each column are connected to each other by means of column fittings (3, 7, 11), **characterized** in that the column fittings (3, 7) have clips (5, 10), each to be received in an opening (2) of the L-plates (1).
2. The system of claim 1, wherein the column fittings (3, 7, 11) have a generally rectangular plate form and wherein each column fitting (3, 7, 11) has two  
10 parallel grooves (4, 8, 12), which grooves (4, 8, 12) extend from one edge of the column fitting (3, 7, 11), perpendicular to said edge, and which to about the middle of each column fitting (3, 7, 11).
3. The system of claim 2, wherein each elongated part of the L-plates (1) have one opening (2) at an upper end, two openings (2) at a lower end and one opening (2)  
15 somewhere between the openings (2) at the upper end and lower end.
4. The system of any of the previous claims, wherein the columns are formed of two L-plates (1).
5. The system of any of the claims 1-3, wherein the columns are formed of four L-plates (1).
- 20 6. The system of claim 5, wherein each column is held together by means of three nodes, wherein each node is formed of four column fittings (3, 7, 11), wherein two mutually identical column fittings (3, 7, 11) are placed parallel to each other and at a distance from each other, wherein two further mutually identical column fittings (3, 7, 11) are placed at a distance from each other and perpendicular to the other two column  
25 fittings (3, 7, 11) and wherein the column fittings (3, 7, 11) of the node are connected to each other by means of the grooves (4, 8, 12) of respective column fitting (3, 7, 11).
7. The system of claim 6, wherein a first type of column fitting (3) is placed in each node with the grooves (4) open upwards and a second or third type of column fitting (7, 11) is placed in the node with the grooves (8, 12) open downwards.
- 30 8. The system of any of the previous claims, further comprising cross beams (24) placed on one or more of the column fittings (3, 7, 11) by means of a beam clips (23) and wherein a beam clip (23) is arranged at each end of each cross beam (24).
9. The system of any of the previous claims, further comprising at least one elongated espalier rail (19) arranged in the area between two adjacent L-plates (1) of a  
35 formed column.

10. The system of claim 9, wherein the espalier rail (19) has a number of openings (20) placed along the length of the espalier rail (19) and wherein the espalier rail (19) has a horizontal part (21) at an upper end, which horizontal part is to be received in a slit (6, 9, 13) of one column fitting (3, 7, 11)

5           11. The system of claim 10, further comprising espalier beams (22) having a beam clip (23) at each end, and wherein the beam clips (23) of the espalier beams (22) are received in the openings (20) of the espalier rails (19).

12. The system of any of the claims 8-11, further comprising a cover beam (25) placed on top of a cross beam (24) or an espalier beam (22) and wherein the cover beam  
10 (25) has narrow protruding ends (26) each to be placed between two adjacent L-plates (1) in a formed column.

13. The system of any of the claims 3-12, further comprising a footing (14), having a vertical part (15) and a horizontal part (16) arranged mutually perpendicular, and which footing (14) is placed at an L-plate (1) of a formed column by means of a clip  
15 (17), arranged on the vertical part of the footing (14) and received in the lowermost opening (2) of one of the elongated parts of the L-plate (1).

14. The system of any of the previous claims, wherein the L-plates (1) are made of metal.

15. The system of any of the claims 1-13, wherein the L-plates are made of  
20 plastic.

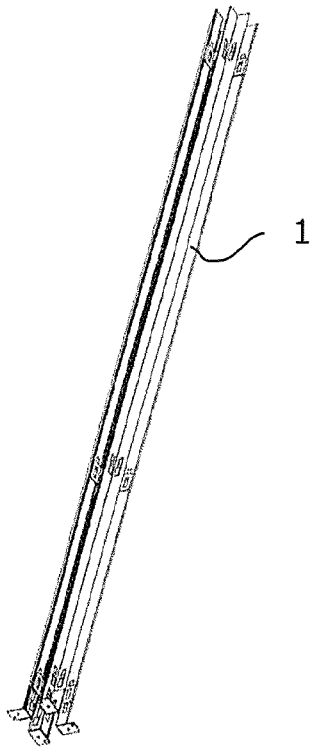

Fig. 1

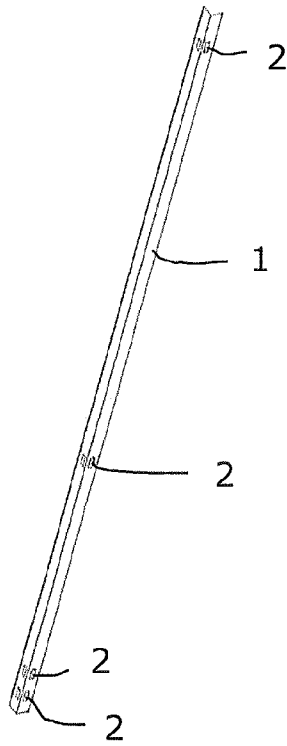

Fig. 2

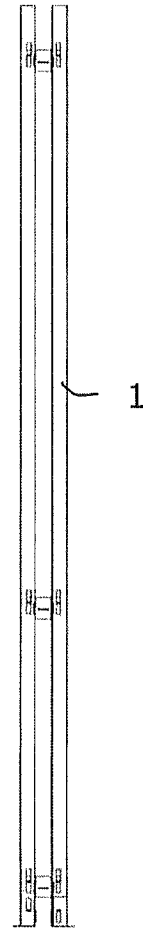

Fig. 3

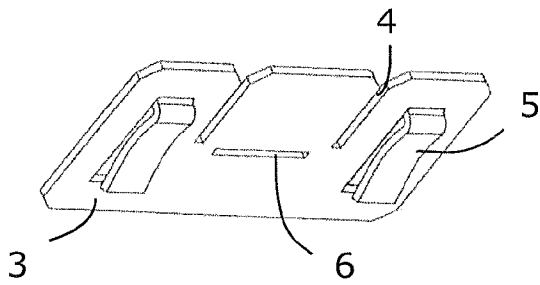

Fig. 4

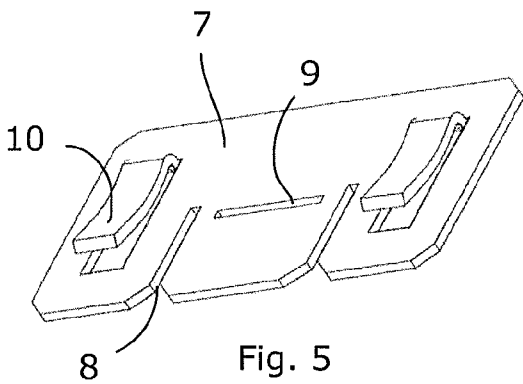

Fig. 5

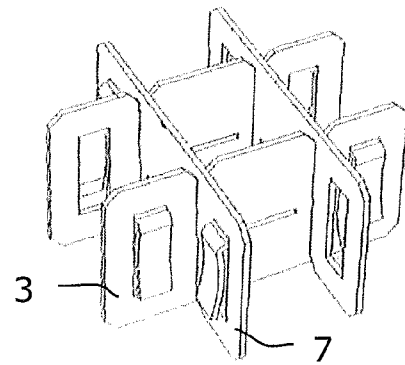

Fig. 6

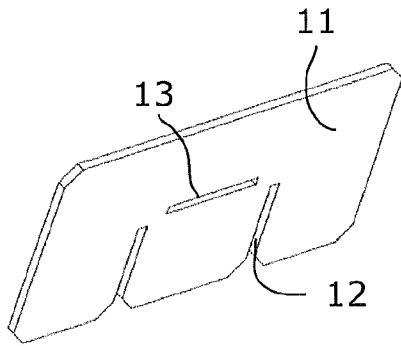

Fig. 7

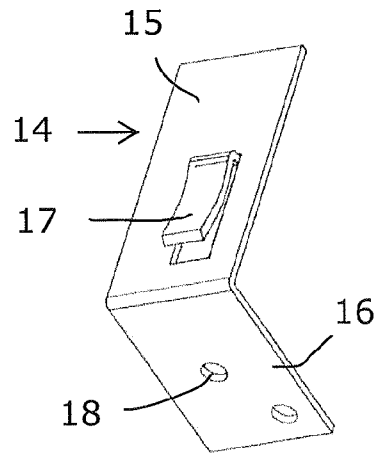

Fig. 8

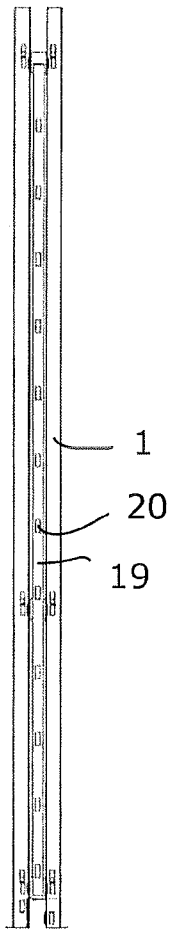

Fig. 9

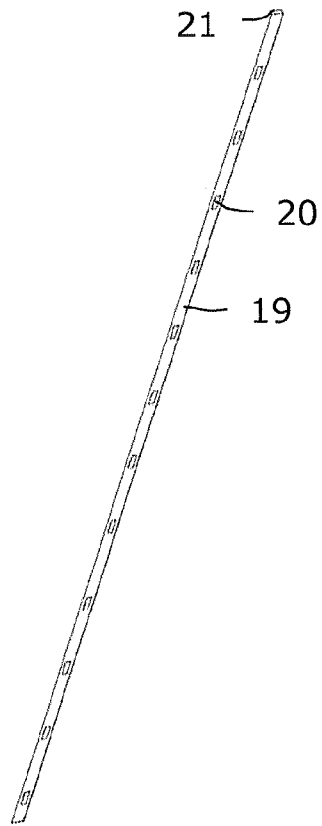

Fig. 10

3/3

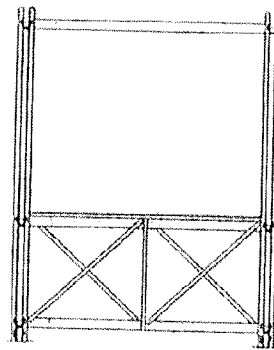
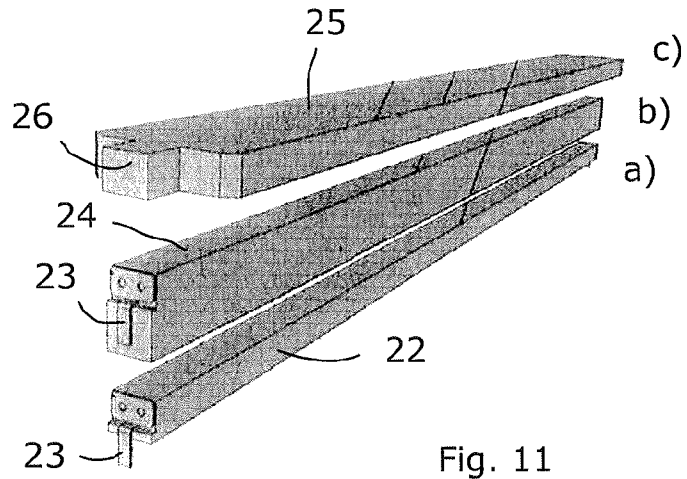

Fig. 12

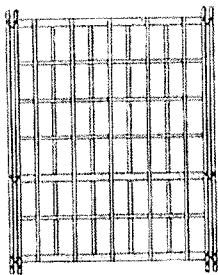

Fig. 13

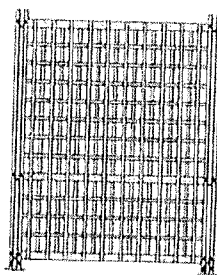

Fig. 14

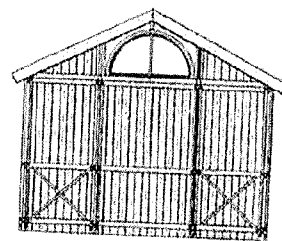

Fig. 15

## INTERNATIONAL SEARCH REPORT

International application No.  
PCT/SE2012/050467

A. CLASSIFICATION OF SUBJECT MATTER		
IPC: see extra sheet		
According to International Patent Classification (IPC) or to both national classification and IPC		
B. FIELDS SEARCHED		
Minimum documentation searched (classification system followed by classification symbols)		
IPC: E04B		
Documentation searched other than minimum documentation to the extent that such documents are included in the fields searched		
SE, DK, FI, NO classes as above		
Electronic data base consulted during the international search (name of data base and, where practicable, search terms used)		
EPO-Internal, PAJ, WPI data		
C. DOCUMENTS CONSIDERED TO BE RELEVANT		
Category*	Citation of document, with indication, where appropriate, of the relevant passages	Relevant to claim No.
A	EP 1485542 B1 (SIMMONS ROBERT J), 15 December 2004 (2004-12-15); paragraphs [0001], [0013], [0019]-[0027], [0032]-[0033], [0041], [0057]; figures 1-15; claim 1 --	1-15
A	US 20040194405 A1 (PEACEY IAN ET AL), 7 October 2004 (2004-10-07); abstract; paragraphs [0074]-[0082]; figures 1,4,9,9a --	1-15
A	GB 806242 A (LEIGHTON MURRAY AUSTIN), 23 December 1958 (1958-12-23); page 1, line 1 - line 48; page 2, line 51 - line 70; figures 1,3,9 --	1-15
<input checked="" type="checkbox"/> Further documents are listed in the continuation of Box C. <input checked="" type="checkbox"/> See patent family annex.		
* Special categories of cited documents: "A" document defining the general state of the art which is not considered to be of particular relevance "E" earlier application or patent but published on or after the international filing date "L" document which may throw doubts on priority claim(s) or which is cited to establish the publication date of another citation or other special reason (as specified) "O" document referring to an oral disclosure, use, exhibition or other means "P" document published prior to the international filing date but later than the priority date claimed "T" later document published after the international filing date or priority date and not in conflict with the application but cited to understand the principle or theory underlying the invention "X" document of particular relevance; the claimed invention cannot be considered novel or cannot be considered to involve an inventive step when the document is taken alone "Y" document of particular relevance; the claimed invention cannot be considered to involve an inventive step when the document is combined with one or more other such documents, such combination being obvious to a person skilled in the art "&" document member of the same patent family		
Date of the actual completion of the international search 29-06-2012		Date of mailing of the international search report 05-07-2012
Name and mailing address of the ISA/SE Patent- och registreringsverket Box 5055 S-102 42 STOCKHOLM Facsimile No. + 46 8 666 02 86		Authorized officer Lena Nord Telephone No. + 46 8 782 25 00

## INTERNATIONAL SEARCH REPORT

International application No.  
PCT/SE2012/050467

C (Continuation). DOCUMENTS CONSIDERED TO BE RELEVANT		
Category*	Citation of document, with indication, where appropriate, of the relevant passages	Relevant to claim No.
A	SE 389527 B (PROFILES & TUBES DE L EST ET AL), 8 November 1976 (1976-11-08); page 1, paragraph [0001] - paragraph [0002]; page 4, paragraph [0003] - paragraph [0005]; figures 3,5,14-16 --	1-15
A	CA 1009013 A1 (WENDT ALAN C), 26 April 1977 (1977-04-26); page 1, line 1 - line 24; figures; claims 1-3 --	1-15
A	JP 11256686 A (SANKEN HOME KK), 21 September 1999 (1999-09-21); (abstract) Retrieved from: PAJ database; Original document: figures --	1-15
A	US 2720291 A (LARKIN JOHN A), 11 October 1955 (1955-10-11); whole document -- -----	1-15

**Continuation of:** second sheet

**International Patent Classification (IPC)**

**E04B 1/24** (2006.01)

**E04B 1/28** (2006.01)

**E04B 2/56** (2006.01)

**E04B 2/62** (2006.01)

**Download your patent documents at [www.prv.se](http://www.prv.se)**

The cited patent documents can be downloaded:

- From "Cited documents" found under our online services at [www.prv.se](http://www.prv.se)  
(English version)
- From "Anförda dokument" found under "e-tjänster" at [www.prv.se](http://www.prv.se)  
(Swedish version)

Use the application number as username. The password is **WOZCSEIUXS**.

Paper copies can be ordered at a cost of 50 SEK per copy from PRV InterPat (telephone number 08-782 28 85).

Cited literature, if any, will be enclosed in paper form.

## INTERNATIONAL SEARCH REPORT

Information on patent family members

International application No.

PCT/SE2012/050467

EP	1485542 B1	15/12/2004	AU	2002244318 A1	08/10/2003
			BR	0209851 A	15/06/2004
			CA	2479217 C	04/10/2011
			CN	101302777 A	12/11/2008
			CN	1623023 A	01/06/2005
			DE	60217552 D1	22/02/2007
			JP	2005520960 A	14/07/2005
			MX	PA04008991 A	01/07/2005
			WO	03080951 A1	02/10/2003
US	20040194405 A1	07/10/2004	NONE		
GB	806242 A	23/12/1958	NONE		
SE	389527 B	08/11/1976	NONE		
CA	1009013 A1	26/04/1977	NONE		
JP	11256686 A	21/09/1999	JP	2962471 B2	12/10/1999
US	2720291 A	11/10/1955	NONE		