

(No Model.)

5 Sheets—Sheet 1.

J. A. LACÔTE.

MACHINE FOR DECORTICATING CHINA GRASS, &c.

No. 524,829.

Patented Aug. 21, 1894.

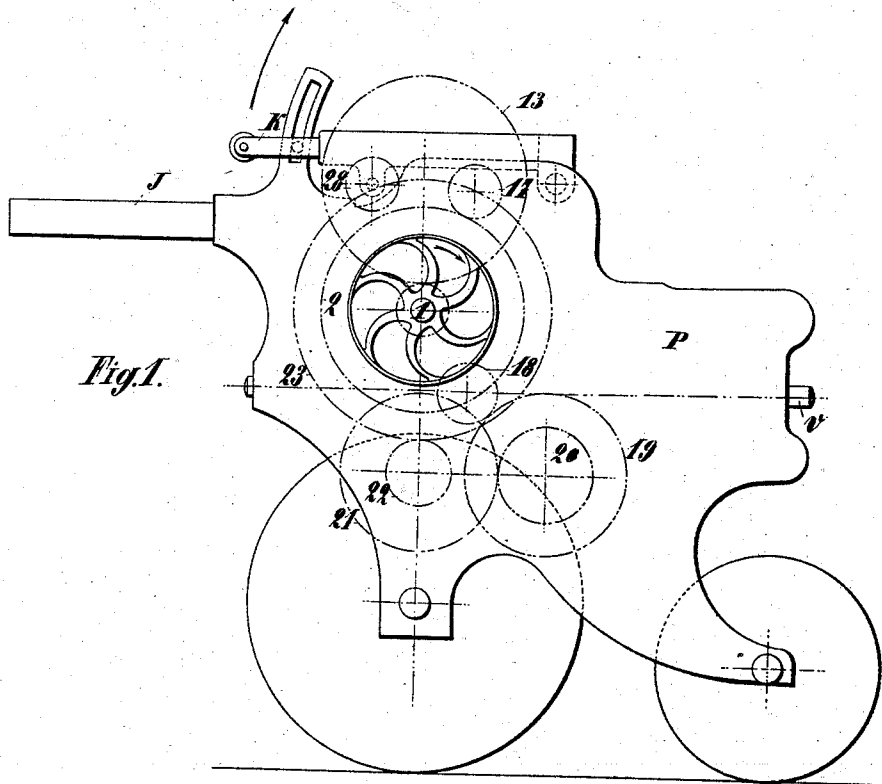

WITNESSES:
H. R. Brennan
S. E. Smith

INVENTOR
J. A. Lacôte
by *Georgel Requier*
ATTORNEYS

(No Model.)

5 Sheets—Sheet 2.

J. A. LACÔTE.

MACHINE FOR DECORTICATING CHINA GRASS, &c.

No. 524,829.

Patented Aug. 21, 1894.

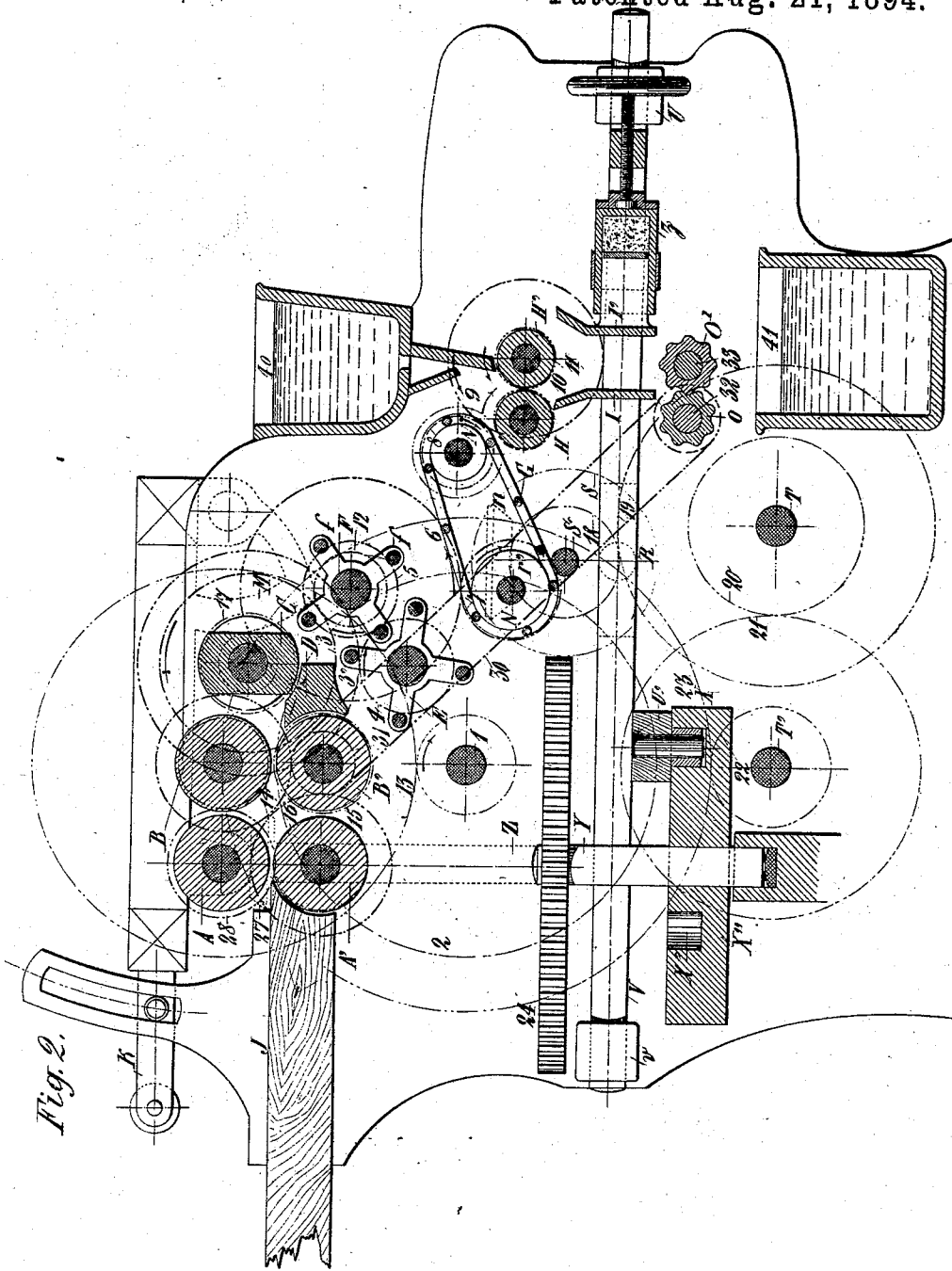

Fig. 2.

WITNESSES:
K. K. Breiman
S. E. Smith

INVENTOR
J. A. Lacôte
by Gospel Paeymer
ATTORNEYS.

J. A. LACÔTE.

MACHINE FOR DECORTICATING CHINA GRASS, &c.

No. 524,829.

Patented Aug. 21, 1894.

Fig. 5.

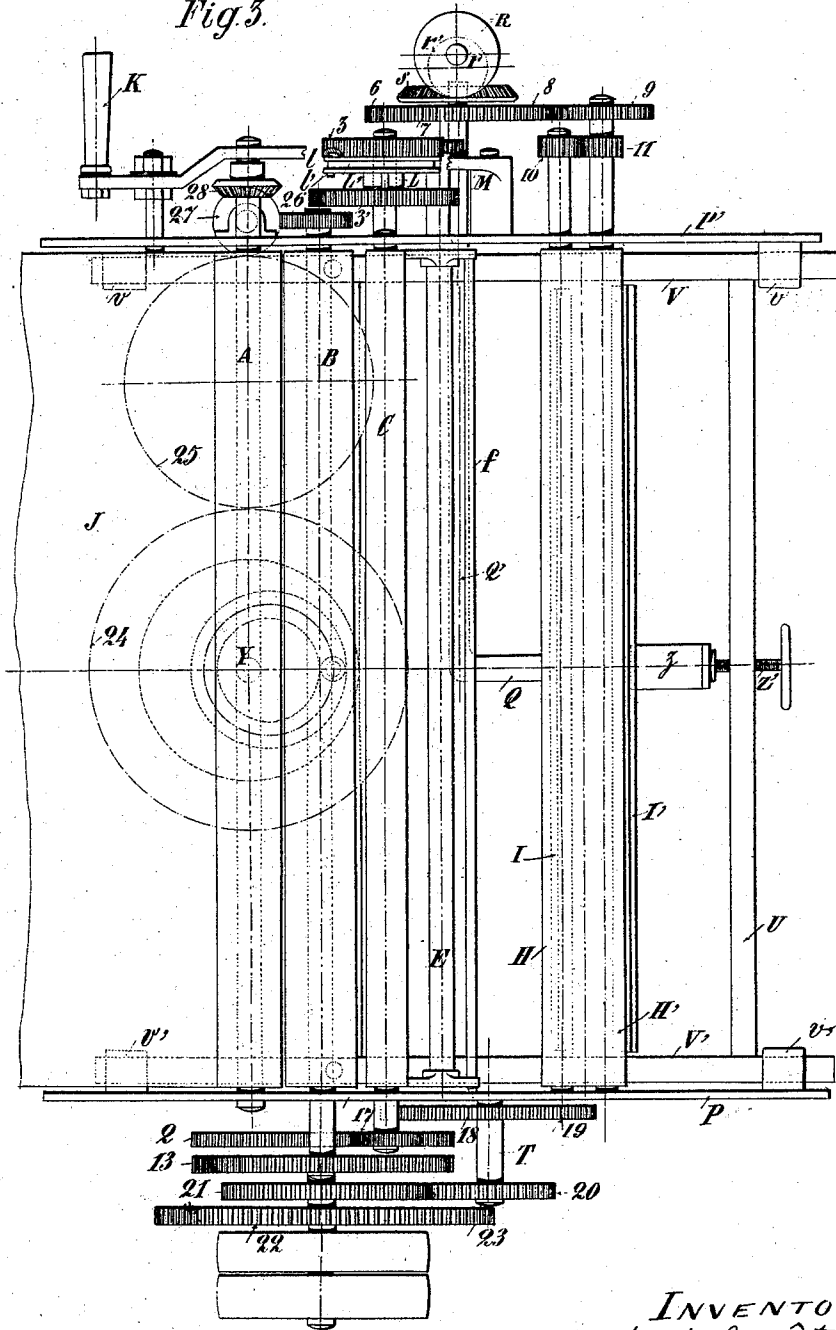

WITNESSES:
H. P. Brennan
S. E. Smith

INVENTOR
J. A. Lacôte
 by *Joseph Raymond*
 ATTORNEYS.

(No Model.)

5 Sheets—Sheet 4.

J. A. LACÔTE.

MACHINE FOR DECORTICATING CHINA GRASS, &c.

No. 524,829.

Patented Aug. 21, 1894.

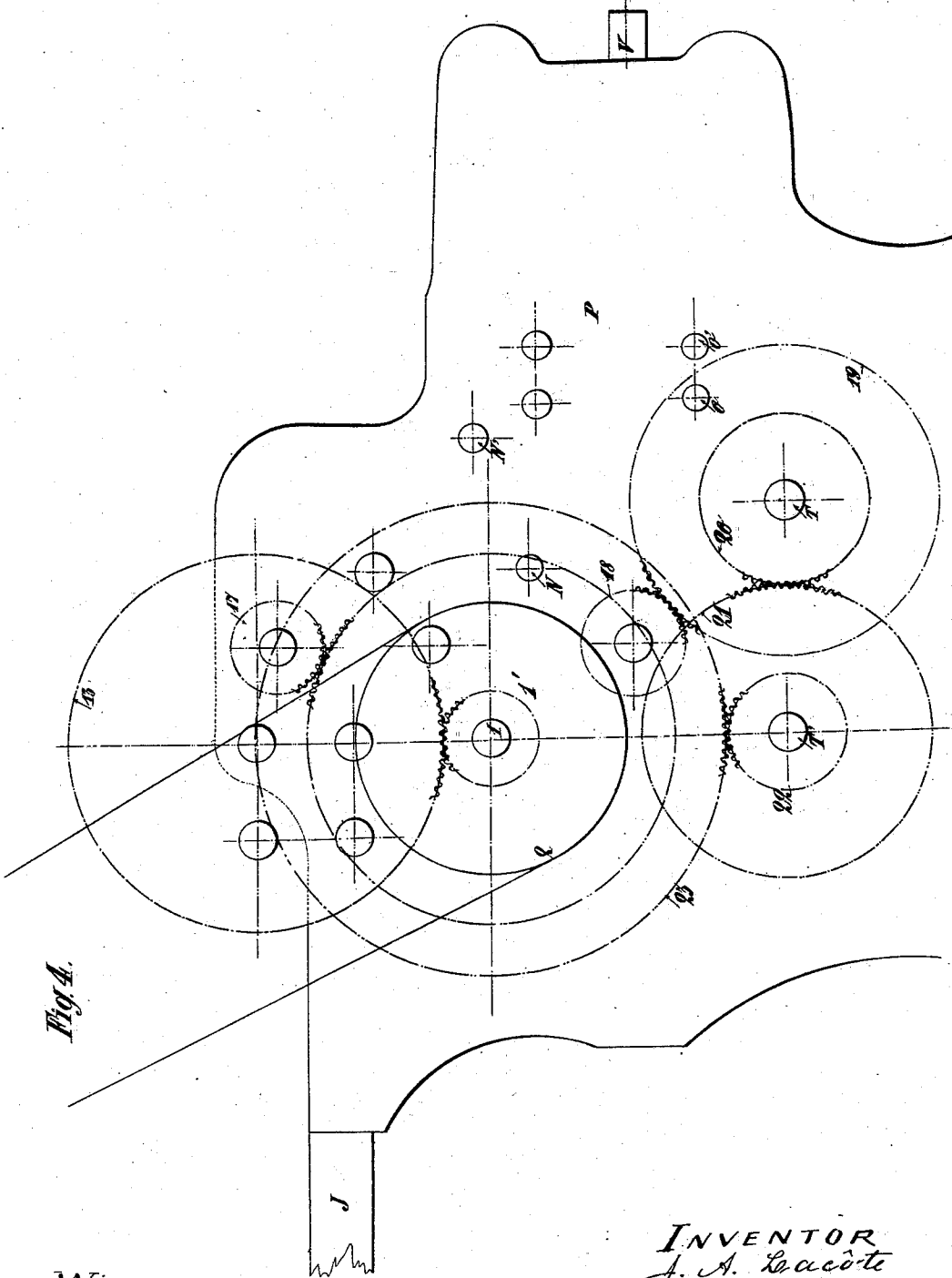

Fig. 4.

WITNESSES:
H. R. Brennan
S. C. Smith

INVENTOR
J. A. Lacôte
by *Guiseppi Rayner*
ATTORNEYS.

(No Model.)

5 Sheets—Sheet 5.

J. A. LACÔTE.

MACHINE FOR DECORTICATING CHINA GRASS, &c.

No. 524,829.

Patented Aug. 21, 1894.

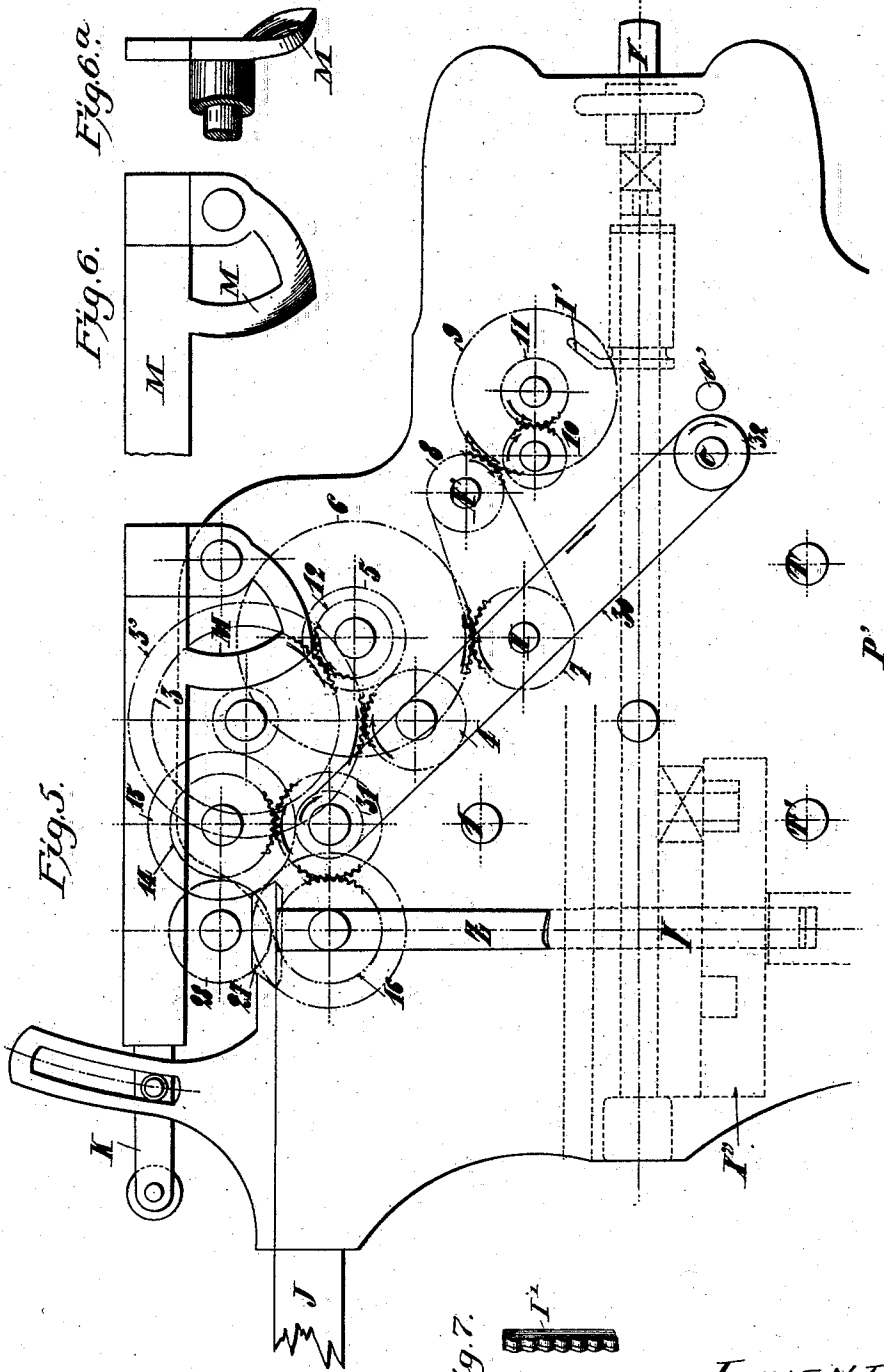

Fig. 5.

Fig. 6.

Fig. 6.^a

Fig. 7.

WITNESSES:
H. R. Breman
S. C. Smith

INVENTOR
J. A. Lacôte
 by *Geipel & Riquin*
 ATTORNEYS

UNITED STATES PATENT OFFICE.

JEAN ALEXANDRE LACÔTE, OF PARIS, FRANCE.

MACHINE FOR DECORTICATING CHINA-GRASS, &c.

SPECIFICATION forming part of Letters Patent No. 524,829, dated August 21, 1894.

Application filed December 5, 1893. Serial No. 492,823. (No model.)

To all whom it may concern:

Be it known that I, JEAN ALEXANDRE LACÔTE, a citizen of the Republic of France, residing at Paris, France, have invented certain new and useful Improvements in Machines for Decorticating China-Grass or Ramie and Like Plants, of which the following is a specification.

This invention relates to certain new and useful improvements in machines for decorticating ramie and like plants.

The object of my invention is to provide a machine of this kind which produces a fine fiber, possessing the inherent resistance and tenacity of the plant, by which machine the leaves or stalks are decorticated throughout their entire length, without the use of chemicals and which machine works very economically and decorticates the plants in the green state and without requiring a previous drying.

The invention consists in the combination with a suitable frame, of feed-rollers, a rotary breaker for breaking the epidermis of the plants resting on a table below the breaker, a pair of beaters adjacent to the table, which beaters detach the broken epidermis from the fiber, movable rods upon which the fibers pass from the beaters and which remove the remaining particles of the epidermis from the fiber, a pair of presser-rollers to which the fiber is conducted and presser-plates, of which one reciprocates readily in the direction of its length.

The invention also consists in the construction and combination of parts and details as will be fully described hereinafter and finally pointed out in the claims.

In the accompanying drawings, Figure 1 is an elevation of one end of my improved decorticating machine. Fig. 2 is a vertical transverse sectional view of the same drawn to a larger scale. Fig. 3 is a plan view of the same. Figs. 4 and 5 are elevations of the two end-plates and the gearing on the same. Figs. 6 and 6^a are respectively detail side and end elevations of the cam-portion of the operating lever, and Fig. 7 is a broken detail top-view showing the corrugations or ribs which are located on the inner faces of the movable plates.

Similar letters and figures of reference indicate corresponding parts.

The ramie stalks or leaves are treated in the machine in the following manner: First. The stalks or leaves are drawn into the machine by means of the plain surfaced feed-rollers A A', B B'. Second. The rotary wooden breaker C acts on the stalks passing between the same and the fixed table D, by which operation the epidermis is broken and cut into small pieces without injuring the exterior fiber. Third. The ramie then passes between the beaters E and F for the purpose of disengaging from the fiber the small pieces of epidermis produced by the preceding operation. Fourth. The ramie passes upon the movable rods G which serve to complete the separating of the pieces of epidermis from the fiber, so that said pieces do not drop down between the rollers H and H' between which the ramie passes after leaving the rods G. Fifth. The ramie passes between two grooved plates I and I' of which one moves slowly to and fro transversely to its length, and the other has a rapid longitudinal reciprocating motion, and by which plates the fiber is converted into filaments that can be subjected to a spinning process. The fibers are drawn downward by the rollers O and O'.

The heat produced by the action of the plates I and I' on the ramie permits of dispensing entirely with the use of chemicals in treating the fiber as has been necessary heretofore. The above are the essential steps of the process and will now be described in detail with the several parts of the machine.

As stated the ramie stalks are arranged on the table J and their forward ends are inserted between the wooden feed-rollers A A', B B'. While the stalks or leaves are being arranged on the table J, the roller A is not in contact with the roller A', so to avoid the stalks or leaves being drawn into the machine before they are properly placed and arranged. The roller A is raised by means of the lever K whereby, as will appear later on, some of the parts of the machine are reversed, so that stalks are not permitted to feed between rollers A A', and the operator is permitted to utilize the interval of rest to prepare fresh stalks on table J. After the stalks have been properly arranged on the table J the roller A is lowered and the two rollers A A' rotated so as to draw in the

stalks which then pass in between the rollers B B', which are rotated at a uniform speed with the rollers A and A'. After leaving the rollers B B' the stalks pass between the fixed table D and the rotating wooden breaker C and while thus passing over the table D the epidermis is broken into small pieces which are disengaged and separated from the exterior fiber by the rotating beaters E and F. The rods G, upon which the fibers now pass disengage the pieces of the epidermis or woody material still adhering to the fiber as the said rods agitate or strike the fibers more or less while conveying it so that when the fiber arrives at the rubber covered rollers H H' it is entirely devoid of any particles of epidermis or woody substance.

If the apparatus works constantly in the same direction, that is to say, if the beaters E, F, the rods G and the rollers H, H' always rotate in the same direction, then, when the rear ends of the ramie or other stalks being treated, reach the beaters E, F, they are no longer held stretched between the rollers H, H', and the breaker C and table D, and the stalks would therefore wind around the said beaters for the reason that the same do not act as a sufficient grip for the stalks and an interruption in the constant working of the apparatus is thereby caused. It is in view of remedying this inconvenience, that I have devised the following arrangement, by which I obtain the reversal in the movements of the beaters E, F, rods G and rollers H, H', at the moment when the rear ends of the stalks arrive at the beaters.

The shaft, on which the wooden breaker C, which breaks and bruises the stalks on the table D is mounted, receives its rotary motion from the main-driving or power shaft 1, by means of the cog-wheels 2 and 17. On the opposite end of the shaft of the beater C, two cog-wheels 3 3' are mounted loosely, and between them a sleeve L is fixed on the shaft and provided with a spline. On this sleeve the sliding circumferentially grooved clutch-pulley L' is mounted, which can be moved against either of the wheels 3 or 3' so as to engage either one or the other by means of the lugs L' on said pulley which lugs enter notches in the sides of the wheels 3 3' so that either the wheel 3 or the wheel 3' can be rotated by said pulley.

As has been stated the lever K is raised when the stalks are to be arranged on the table J, in such a manner that their ends rest on the roller A', at which time the rear ends of the stalks previously fed into the machine arrive at the table D and breaker C and at which time the beaters E and F, the rods G and the rollers H H' must be reversed. This change of direction is made the instant the lever K is raised, as said lever has a beveled arm M which passes into the circumferential groove of the pulley L' and moves the latter in the direction of the length of the sleeve by acting on the sides of the groove in such a

manner that one cog-wheel 3 or 3' is disengaged from the pulley and the other engaged therewith.

Forward movement.—The cog-wheel 2 rotates in the direction of its arrow Fig. 2 and the pinion 17 engaged by the cog-wheel 2 is rotated in the direction of the arrow. The clutch pulley L' is engaged with the cog-wheel 3' which is rotated and as it engages the cog-wheel 4 on the shaft of the beater E, the latter is rotated in the direction of its arrow Fig. 2. The beater F is in turn rotated from the beater E by the engaged cog-wheels 4 and 5. By means of the cog-wheel 6 engaging the cog-wheel 7 on the shaft N, the latter is rotated in the direction of its arrow and from the shaft N motion is transmitted to the shaft N' by the two chains n which are connected by the rods G. By means of the cog-wheels 8 and 9 motion is transmitted to the roller H' from which motion is transmitted by means of the cog-wheels 10 and 11 to the roller H which rollers are rotated in the directions indicated by the arrows in Fig. 2. The beaters, the rods G and the rollers H and H' are operated in such a manner and direction as to move the ramie toward the rollers O and O' by which the fibers are drawn downward.

Backward movement.—The lever K is raised and the curved arm M moves the pulley L' in such a manner as to disengage it from the cog-wheel 3' and engage it with the wheel 3 which is now rotated, the wheel 3' running idle, as it, as well as the wheel 3, is loose on the beater shaft. The beaters are now rotated inversely by the cog-wheel 3 which engages the cog-wheel 12 on the shaft of the beater F, and the beater E is also rotated inversely by means of the cog-wheels 4 and 5. For the forward movement the beater F rotates the beater E and for the backward movement the beater E rotates the beater F. The movements of the other parts take place in the manner described but in inverse direction, the cog-wheel 6 on the shaft of the beater F turning in the inverse direction. The beaters and the rods G moving in inverse direction do not have less effect on the ramie since the same is held between the plates I I', so that the action of the plates on the ramie is uniform.

So that the construction and operation of the machine will be fully understood I will now describe the several parts in detail:

First. On one end of the power shaft 1 the pinion 1' is mounted which engages the cog-wheel 13 on the end of the shaft of the roller B which is thus rotated. On the opposite end of said shaft is mounted the cog-wheel 14 which by means of the cog-wheels 15 and 16 rotates the rollers A' and B'. The roller A which is sometimes raised and sometimes lowered, is rotated when lowered by friction from the roller A'.

Second. The breaker C which serves to break the epidermis of the ramie as the same passes over the table D is operated as fol-

lows:—The power shaft 1 carries a cog-wheel 2 which engages and rotates the pinion 17 on the shaft of said breaker C.

Third. The gearing for operating the beaters, the rods G and the rollers H H' has been described heretofore and the detailed construction of said parts is as follows: The beaters are composed of star-shaped end plates mounted on the beater shafts adjacent to the side-walls of the machine frame, the ends of the arms of the star-shaped end-plates on the same shaft being connected by the rods f. The shafts of the beaters are so arranged that the arms of the beaters cross and can bend the ramie passing between them. The rods G which serve, as previously stated, for disengaging the pieces of epidermis from the fiber, are fastened at their ends to endless chains n arranged adjacent to the side walls of the frame, which chains pass over suitable pulleys on the shafts N N' carrying the cog-wheels 7 and 8 previously mentioned. The rollers H H', the driving-gear of which has been described, are covered with rubber so as not to injure the fiber which is much more delicate than the stalks that pass through the parts in advance of the said rollers.

Fourth. The plates I I' and the mechanism for operating the same: These two plates are made of bronze and are grooved vertically and whereas the plate I' is relatively stationary the plate I has a very rapid reciprocating motion in the direction of its length. If the said two plates would at all times remain in contact, the fiber between the same would not be moved forward, and in order to avoid this difficulty the plate I' is so mounted and arranged that at times it moves from the plate I. By moving the plate I' from the plate I the heat which is generated very rapidly between the plates is permitted to escape. The plate I, is as stated above, reciprocated with great rapidity and for the purpose of being thus operated it is connected by the rod Q' having a bend at Q with the eccentric R, fixed on the vertical shaft r, driven from the shaft S' by means of the bevel cog-wheels r' and S. The shaft S' is rotated at high speed by means of the cog-wheel 18 which engages the cog-wheel 19 on the shaft T, which in turn is rotated by the cog-wheels 20 and 21 from the shaft T' and said shaft T' is rotated by means of the cog-wheels 22 and 23 from the power shaft 1. It is apparent that the above-described gearing rotates the shaft S' at a speed that is very much greater than that of the shaft 1. The plate I' as stated, from time to time moves from the plate I to permit the fiber to descend. The said plate I' is connected with a transverse bar U attached at its ends to the bars V V' mounted to slide on the guides v and v'. These two bars are connected by a second transverse bar U', provided with a pin X that projects into an eccentric groove X' in the disk X² on the vertical shaft Y. The shaft Y carries the cog-wheel 24, which is rotated from the shaft Z

by means of the cog-wheels 25 and 26 the latter being fixed on the shaft Z. On the upper end of the shaft Z which is outside of the side-wall P' of the machine frame the bevel cog-wheel 27 is fixed, which is engaged by the bevel cog-wheel 28 on the shaft of the roller A. When the roller A is lowered, that is, when it is being rotated, its motion is transmitted to the shaft Y, and its disk X² by means of the cog-wheels 26, 25 and 24. The grooved disk actuates the pin X and by means of the transverse bar U' and the bars V V', which move parallel to the side-walls P P' of the machine-frame, the bar N and the plate I' are moved to and from the plate I.

To permit of regulating the pressure that the plate I exerts on the plate I', the latter is not rigidly connected with the bar U, but is connected by means of a screw Z' which permits of adjusting the relative positions of the plates I and I'. A cushion z of compressible material is placed between the screw and the plate I' for the purpose of avoiding severe shocks being produced by the plates when they come in contact under the action of the eccentric groove X' on the pin X. The grooved rollers O O' are also covered with rubber the same as the rollers H H'. The roller O receives its motion by means of a chain which passes over a sprocket-wheel 31 on the shaft of the roller B'. Motion is transmitted from the roller O to the roller O' by means of the cog-wheels 32 and 33 Fig. 2.

In case green ramie stalks are to be treated, water is permitted to flow upon the plates I and I' from a tank, the water collecting in a tank 41 from which it is again elevated to the trough 40.

To sum up, the action of the machine is as follows:—The stalks are fed into the machine, being held and moved along by the feed-rollers A A' and B B', are crushed between the breaker C and plate D, are then beaten or scutched between the beaters E and F and delivered by the traveling rods G to the rubber covered rollers H H', which serve to draw the fibers along and feed them between the plates I I', the parts all moving in the directions indicated by the arrows. After passing between the plates I I', the decorticated ramie or other stalks which are now reduced to fibers, are caught by the grooved feed-rollers O and O'. The action of these rollers on the ramie is more powerful than the action of the rubber covered rollers H and H' and as a matter of fact, it could be said that it is the rollers O and O' which draw the ramie through the machine. When the rear ends of the stalks pass from the feed-rollers D D', the motion of the breaker C, beaters E and F and of rollers H and H' is reversed. Rollers H and H' are reversed as well as are the breaker C and beaters E and F. The reverse rotation of the rollers H and H' whose action on the ramie is not so strong as the action of rollers O and O' only serves to cause the rollers H and H' to act as a sort of brake, and to hold

the ramie during its passage between the plates I and I'.

Having thus described my invention, I claim as new and desire to secure by Letters Patent—

1. In a machine for decorticating ramie and like plants, the combination with a rotary breaker, of a table located below the breaker, over which table the plants under treatment pass and upon which they are subjected to the action of the rotary breaker, feed-rollers for conducting the plants to the breaker, rotary beaters for beating the plants after they have passed the breaker, a set of movable rods upon which the plants pass after leaving the beaters which rods are located below the beaters, a pair of yielding presser-rollers to which the plants are conducted and two vertical plates arranged below the rollers and having their lengths parallel with the axes of the rollers, one of said plates being mounted to reciprocate in the direction of its length, substantially as set forth.

2. In a machine for decorticating ramie and like plants, the combination with feed-rollers, of a rotating breaker beyond the feed-rollers, a table below the breaker over which table the plants pass, two rotating beaters adjacent to the table, each beater being formed of star-shaped end-plates united by rods, two endless chains mounted below the beaters and pulleys over which said chains pass, rods uniting the endless chains, rollers below the chains and rods, a set of pressing plates below the rollers, which pressing plates have their lengths parallel with the axes of the rollers and means for reciprocating one of said plates in the direction of its length, substantially as set forth.

3. In a machine for decorticating ramie and like plants, the combination with means for breaking the epidermis of the plants, means for detaching the broken epidermis from the fiber, two parallel plates between which the fiber is conducted after the epidermis has been removed, said plates being arranged parallel with the axes of the rollers means for reciprocating one of said plates in its longitudinal direction and means for moving the other plate slowly toward and from the longitudinally reciprocating plate transversely to the length of the plate, substantially as set forth.

4. In a machine for decorticating ramie and like plants, the combination with feed-rollers, of means for raising one of the feed-rollers, a breaker for breaking the epidermis of the plants, beaters for removing the broken epidermis from the fibers and means for operating them, a pair of presser plates to which the fibers are conducted, means for reversing the operation of the beaters when the above

mentioned feed-roller is raised and means for drawing the stalks through the machine, substantially as set forth.

5. In a machine for decorticating ramie and like plants, the combination with feed-rollers, of a lever for raising one of said rollers, a curved arm or cam-portion on said lever, a clutch-pulley having a peripheral groove into which said curved arm extends, two sets of gearing, either set being adapted to be engaged by said clutch-pulley and to drive parts of the machine in inverse direction, a shaft carrying the clutch-pulley and the gearing which is engaged thereby, a breaker on said shaft, devices for separating the fibers from the epidermis of the plants after they have passed the breaker, means operated by the above-mentioned gearing for actuating the separating devices, a pair of presser-plates between which the fibers are delivered, and means for drawing the stalks through the machine, substantially as set forth.

6. In a machine for decorticating ramie and like plants, the combination with feed-rollers and mechanism for breaking the epidermis of the plants, of means for removing the broken epidermis from the fibers, a pair of rubber covered rollers, a pair of presser-plates I, I', below the roller, their length being parallel to the axes of the rollers, mechanism for longitudinally reciprocating the plate I, a cross-bar, a screw passing therethrough and connected with the plate I', a cushion between said cross-bar and the screw, means for moving said cross-bar and plate toward said longitudinally reciprocating plate in a direction at right angles to the length of said plate, substantially as set forth.

7. In a machine for decorticating ramie and like plants, the combination with feed-rollers, of a table and a rotary breaker for breaking the epidermis of the plants, means for removing the broken epidermis from the fiber and moving the fiber, a pair of presser rollers, a pair of presser-plates below the presser rollers, which have their lengths parallel with the axes of the rollers, means for reciprocating one of the presser-plates longitudinally, a cross-bar connected with the other plate, sliding side-bars connected with the cross-bar, an additional cross-bar connected with the sliding side-bars, a pin projecting from said two cross-bars and a pulley having a central groove into which said pin passes, substantially as set forth.

In testimony whereof I have signed this specification in the presence of two subscribing witnesses.

JEAN ALEXANDRE LACÔTE.

Witnesses:

CLYDE SHROPSHIRE,
JOSEPH CACERT.