

S. C. DAVIDSON.
 APPARATUS FOR DRYING TEA, GRAIN, OR OTHER SUBSTANCES.
 APPLICATION FILED APR. 13, 1908.

940,237.

Patented Nov. 16, 1909.

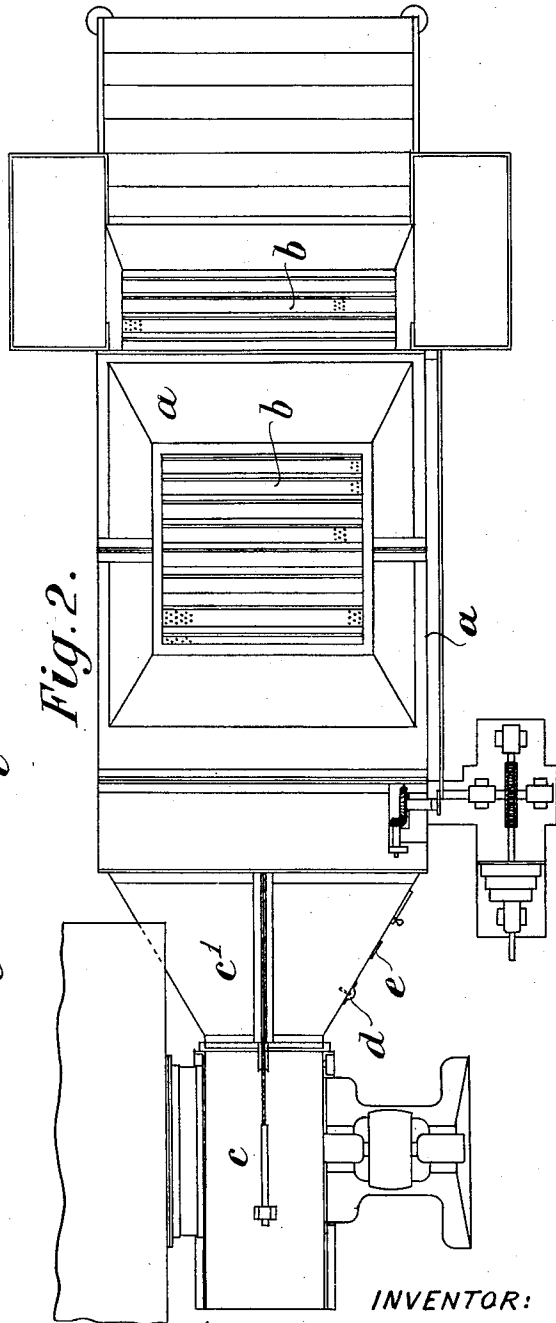
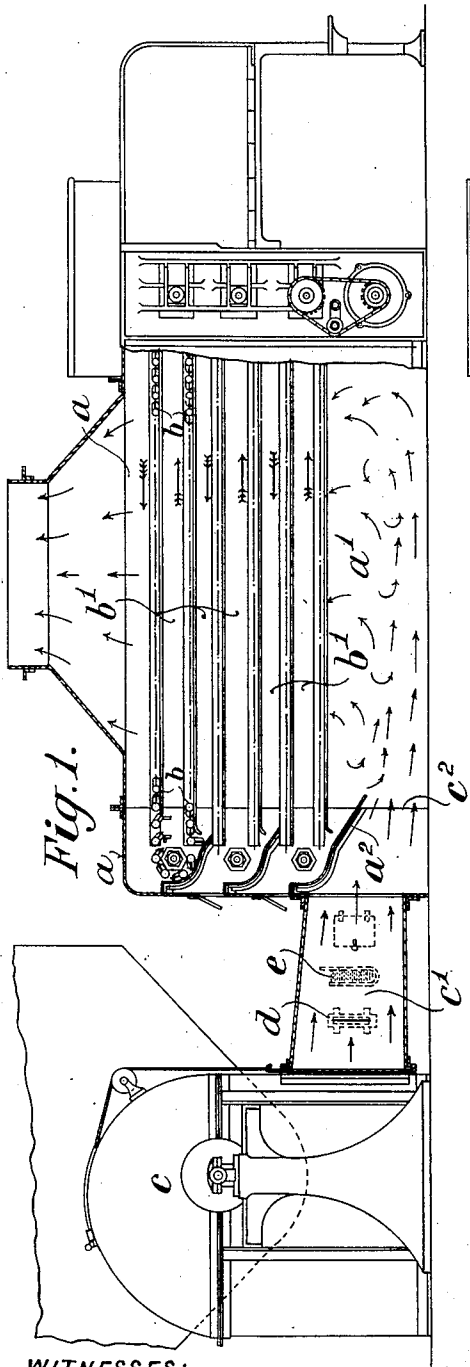

WITNESSES:

Ired White
Rene' Mine

INVENTOR:

Samuel Coldland Davidson,

By Attorneys,

Arthur C. Kaiser & Co.

UNITED STATES PATENT OFFICE.

SAMUEL CLELAND DAVIDSON, OF BELFAST, IRELAND.

APPARATUS FOR DRYING TEA, GRAIN, OR OTHER SUBSTANCES.

940,237.

Specification of Letters Patent.

Patented Nov. 16, 1909.

Application filed April 13, 1908. Serial No. 426,870.

To all whom it may concern:

Be it known that I, SAMUEL CLELAND DAVIDSON, of Sirocco Engineering Works, Belfast, Ireland, merchant, have invented certain new and useful Improvements in or Relating to Apparatus for Drying Tea, Grain, or other Substances, of which the following is a specification.

My improvements relate to the type of drying apparatus wherein layers of the material to be dried are so exposed to the action of heated or desiccated air upon a superimposed series of endless belts of foraminous material or trays (hereinafter called the trays) that said air permeates through the material upon the trays and where the material to be dried passes down from one belt to the next below.

Such apparatus as hitherto made operates with a suction fan mounted on the top of the drying chamber, which draws the air through same, and the material therein, but when so acting the partial vacuum thereby set up within the drying chamber sucks in cold or undesiccated air through any openings or crevices in the sides of the drying chamber, which reduces the drying capacity of the air coming direct from the air heating or desiccating apparatus, and less evaporation is obtained from this air than if same were forced into and through the drying chamber, and a pressure or plenum maintained therein against which no external air can enter through crevices, and the heated or desiccated air consequently operates with its full effect upon the material, and a higher drying efficiency is obtained from a given volume than when the air current is produced by suction.

When the volume of heated or desiccated air, which has to be forced under pressure through the drying chamber is large relatively to the size of the apparatus which forms the subject of the present invention, and then discharged into the atmosphere; it has hitherto been found difficult in practice to get same introduced direct from a fan or other air propelling device into the drying chamber without disturbing or blowing about the material on the trays against which it first impinges or comes in contact and without its drying the material unevenly in patches and hence notwithstanding that the suction system of drawing the air through the drying chamber is usually less efficient as regards evaporation for the

volume of air employed the suction system has hitherto been more generally used by reason of its producing a more even flow of air through the material without disturbing same on any of the trays.

Now the objects of my invention are to obviate the above described defects of the pressure system in that type of drying apparatus where a relatively large volume of air is to be driven through the drying chamber and discharged into the atmosphere without being recirculated and to render attainable in practice the higher efficiencies which pertain to the employment of such system.

According to this invention I employ in the base of the drying chamber beneath the lowermost belt of trays an air pressure chamber or inclosed space of a greater depth than the inlet opening through which a relatively large volume of heated or desiccated air is forced into said space said inlet opening being situated at one end of said pressure chamber and of a width approximately equal to the width of the belts of trays whereby the air entering therefrom shall flow in a direction parallel with the to and fro movement of the said belt as a layer of air along the floor of said pressure chamber and of approximately the full width of said belts the result being that practically uniform pressure is maintained in the upper part of the said space or pressure chamber over the full area of the trays.

The accompanying drawings illustrate the invention as applied to an apparatus wherein the material to be dried is carried upon a series of trays arranged as endless belts.

Figure 1 is a part sectional side elevation of the apparatus. Fig. 2 is a plan of same.

Referring to the drawings I employ within the drying chamber *a*, endless belts of superimposed trays *b* the general arrangement and operation of which are as shown and described in the specification of a patent granted to me and J. S. Davidson in Great Britain under No. 15325 dated 5th. July 1906.

In constructing the apparatus means are provided as shown for opposing as far as possible the direct flow of air around the ends of the trays. Such means are shown as aprons or shields *a'* arranged at the ends of the device.

Into one end of the large space *a'* beneath the lowest row of trays *b* I force heated or desiccated air by a fan *c* or other suitable

air propelling device, through a duct c' which as shown in Fig. 2 is widened out to the full width of the inlet opening c^2 which extends for the full width of the drying chamber or the belts therein, the height of the inlet opening is made much less than the height of the pressure chamber. In this construction as herein illustrated the restriction of the height of the inlet opening is obtained by extending the lower inclined apron or shield plate a^2 downward as shown. The heated or desiccated air is forced through the restricted opening c^2 in such volume and at such velocity as will cause the entering air to flow as a layer along and to the farther end of the floor of the pressure chamber in a direction parallel with the to and fro movement of the trays, the effective result of which is that the equal distribution of said air and at practically a uniform pressure is set up over the full area of the trays, the operative effect of which is to force the air up through the layer of material on the line of trays b immediately over it into the space b' between same and the layer of material on the next line of trays above it, which layer acts as a resistance and sets up an effective back pressure within said space b' down against the upper surface of the material on the lower or first line of trays and thereby causes a positive contact of the air therewith and an effective drying action. The pressure in this space b' then acts on the layer of material on the next line of trays above it in the same manner as the pressure in the bottom chamber a' acts on the material on the first or lower line of trays and sets up a positive pressure in the space between the second and third layers and so on to the top layer with a gradually diminishing pressure in each succeeding space but there being substantially free escape for the air from the top layer of trays there is little or no back pressure on the upper surface of the material thereon if the exit from the hood or cover is of sufficient area but the said exit may be reduced to such area as will give a certain amount of back pressure on the upper layer or belt if required. The moist material to be dried is spread on the top line of trays and becomes gradually drier as it descends through the drying chamber a to the lowest line of trays from which it is discharged in the required condition of dryness.

If desired a thermometer d and pressure gage e may be introduced into the apparatus at the points indicated in the drawings, namely, in the duct c' or in other suitable places.

The fan c or like mechanical means is usually disposed between the air heater (not shown) and the drying apparatus, and the air heater may be of any ordinary type but I preferably employ the type described in

my prior United States Letters Patent No. 867,72 dated 8th. October 1907.

What I claim and desire to secure by Letters Patent is:—

1. In drying apparatus the combination with a drying chamber, a series of endless belts of trays therein, means for opposing the flow of air around the ends of said trays, an air pressure chamber in the base of said drying chamber, the lower end of said belts of trays forming the upper wall of said pressure chamber, and an inlet duct relatively narrow in comparison with the depth of the pressure chamber and disposed next the floor thereof whereby the air forced in through said inlet opening passes as a layer along the floor of the pressure chamber before being distributed therein substantially as set forth.

2. In drying apparatus, the combination of a drying chamber a superimposed series of endless belts of trays in said drying chamber, means for opposing the flow of air around the ends of said trays, an air inlet opening into the base of the drying chamber next the floor thereof and extending across the full width of the drying chamber, means for forcing a relatively large volume of air into the drying chamber through said air inlet, and an air pressure chamber formed by an inclosed space in the base of the drying chamber and into which the said air inlet opens, said air pressure chamber being of a greater depth than the said inlet opening, whereby the air forced in through said inlet opening flows in a direction parallel with the to and fro movement of the belt of traveling trays and as a layer along the floor of said pressure chamber and of approximately the full width of said belt of trays, substantially as and for the purposes set forth.

3. In drying apparatus wherein the material to be dried is carried on belts of trays, the combination with means for opposing the flow of air around the ends of said trays, and a pressure chamber comprised by an inclosed space in the base of the drying chamber of means for forcing a relatively large volume of air into one end of said pressure chamber as a layer of air along the floor thereof and of the full width of the pressure chamber and parallel with the to and fro movement of the trays, substantially as and for the purpose set forth.

4. In drying apparatus wherein the material to be dried is carried upon endless belts of trays, the combination with means for opposing the flow of air around the ends of said trays, and a pressure chamber comprised by an inclosed space in the base of the drying chamber of an air inlet opening into one end of said pressure chamber and a deflecting plate extending from a position adjacent to the lowermost belt of trays downward over said air inlet so as to restrict the height thereof in relation to the height of

the pressure chamber substantially as and for the purpose set forth.

5 5. In drying apparatus wherein the material to be dried is carried upon endless belts of trays, the combination with means for opposing the flow of air around the ends of said trays, and a pressure chamber comprised by an inclosed space in the base of the drying chamber, of an air inlet opening into one end of said pressure chamber, an inclined deflecting plate extending downward over the inlet opening so as to form a gradually restricted air duct leading into said pressure chamber and whereby the entering air is caused to flow along the floor in a wide flat stream of less height than the pressure chamber and of substantially the full width of the drying chamber, substantially as and for the purposes set forth.

20 6. In drying apparatus the combination with a drying chamber, a series of endless belts of trays therein, means for opposing the flow of air around the ends of said trays, an air pressure chamber in the base of said drying chamber, an inlet duct relatively narrow in comparison with the depth of the pressure chamber and disposed next the floor thereof whereby the air forced in through said inlet opening passes as a layer along the floor of the pressure chamber before being distributed therein, and means for discharging the air from the top of said drying chamber into the atmosphere.

35 7. In drying apparatus wherein the material to be dried is carried upon endless belts of trays, the combination with means

for opposing the flow of air around the ends of said trays, and a pressure chamber comprised by an inclosed space in the base of the drying chamber, of an air inlet opening into one end of said pressure chamber, a deflecting plate extending from a position adjacent to the lowermost belt of trays downward over said air inlet so as to restrict the height thereof in relation to the height of the pressure chamber, and means for discharging the air from the top of said drying chamber into the atmosphere.

8. In drying apparatus, means for supporting the material in a series of separated layers, means for opposing the flow of air around the ends of said separated layers, a pressure chamber arranged in the base of the apparatus, and means for forcing a relatively large volume of air into said pressure chamber in a direction parallel to the supporting means, the lowest of said supporting means forming the upper wall of said pressure chamber and said chamber being relatively deep and the inlet for air relatively shallow, to effectually distribute the entering air and cause it to ascend uniformly through the layers of material, substantially as and for the purposes set forth.

In witness whereof, I have hereunto signed my name in the presence of two subscribing witnesses.

SAMUEL CLELAND DAVIDSON.

Witnesses:

GEORGE GOULD WARD,
SAMUEL CRAIG NELSON CARR.