

Feb. 18, 1930.

G. I. HOHL ET AL

1,747,367

CIRCULAR FEEDING AND FOLDING MECHANISM

Filed Dec. 29, 1928

3 Sheets-Sheet 1

Fig. 1

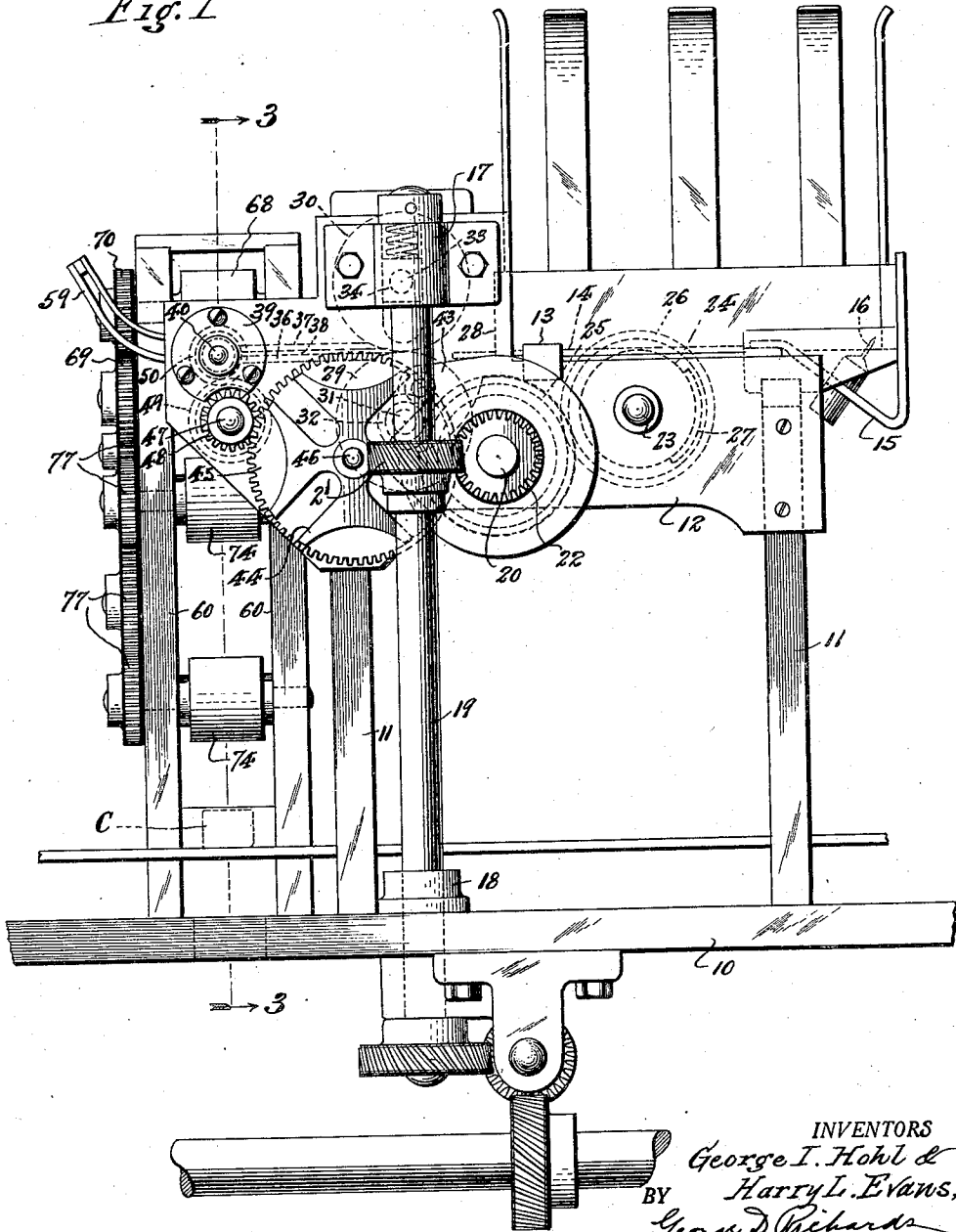

INVENTORS  
George I. Hohl &  
Harry L. Evans,  
BY  
George D. Richards  
ATTORNEY.

Feb. 18, 1930.

G. I. HOHL ET AL

1,747,367

CIRCULAR FEEDING AND FOLDING MECHANISM

Filed Dec. 29, 1928

3 Sheets-Sheet 2

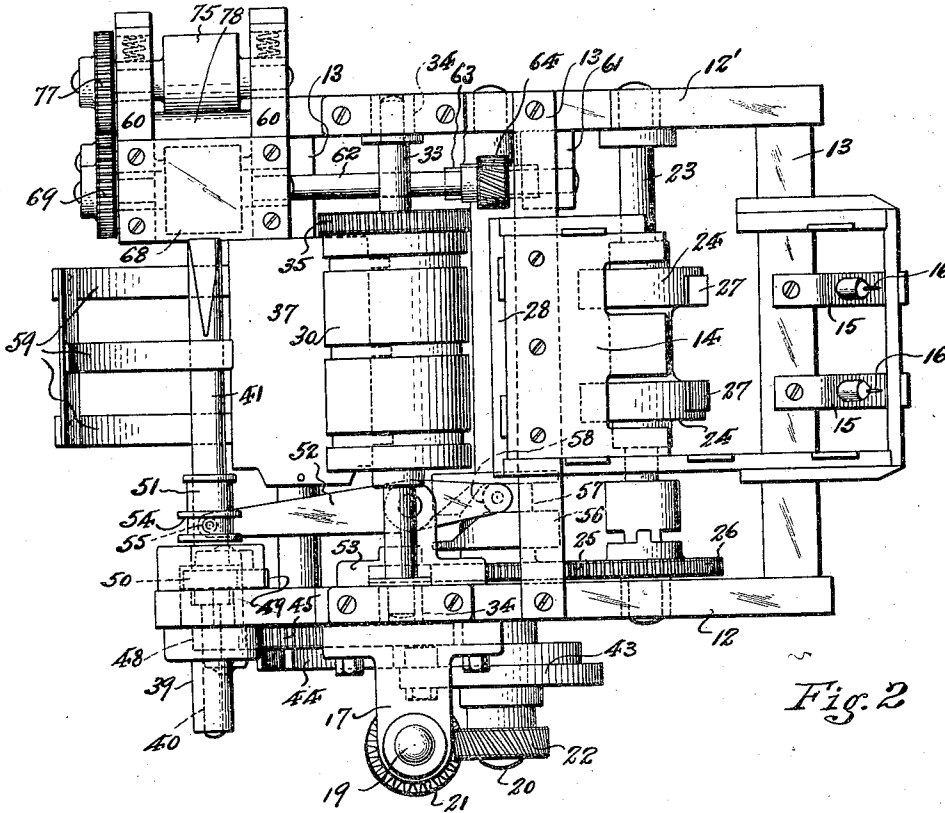

Fig. 2

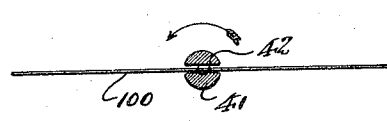

Fig. 5

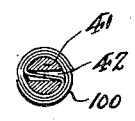

Fig. 6

INVENTORS  
George I. Hohl &  
BY Harry L. Evans,  
George D. Richards  
ATTORNEY.



# UNITED STATES PATENT OFFICE

GEORGE I. HOHL AND HARRY L. EVANS, OF NEWPORT, RHODE ISLAND, ASSIGNORS  
TO CARTONING MACHINERY CORPORATION, OF NEWPORT, RHODE ISLAND, A  
CORPORATION OF NEW JERSEY

## CIRCULAR FEEDING AND FOLDING MECHANISM

Application filed December 29, 1928. Serial No. 329,176.

This invention has reference, generally, to improvements in circular feeding and folding mechanism; and the invention relates, more particularly, to a circular feeding and folding mechanism which is capable of independent use or as an incorporated part of article wrapping and cartoning machinery.

The invention has for its principal object to provide a novel automatic mechanism adapted to feed flat circulars and similar matter from a supply, and then fold the same upon themselves into a formation of reduced size suitable for insertion in a container or package.

The invention has for a further object to provide a novel rotary folding mechanism adapted to first roll a circular or the like upon itself into a tubular formation, in combination with means to receive said tubular formation and flatten the same into the desired folded body ready for insertion in a container or package.

Other objects of this invention, not at this time more particularly enumerated, will be clearly understood from the following detailed description of the same.

The invention is clearly illustrated in the accompanying drawings, in which:—

Figure 1 is a front side elevation of one embodiment of the novel circular feeding and folding mechanism, made according to the principles of this invention; Figure 2 is a top or plan view of the same; Figure 3 is a transverse vertical section through the same, taken on line 3—3 in Figure 1; Figure 4 is a fragmentary sectional view similar to that of Figure 3 but showing the functioning of means for transferring the circular from the rolling spindle to the flattening rolls of the mechanism; Figure 5 is a fragmentary cross section through the rolling spindle, showing the relation of a circular thereto preparatory to the rolling operation; Figure 6 is a view similar to that of Figure 5 but showing the completion of the circular rolling operation; and Figure 7 is a perspective view of the finished folded circular.

Similar characters of reference are employed in all of the hereinabove described views, to indicate corresponding parts.

Referring now to said drawings, the reference character 10 indicates a suitable base upon which the circular feeding and folding mechanism is mounted. Supported above said base by suitable standards 11 are a pair of laterally spaced apart side plates 12 and 12' which are retained in such relation by interconnecting cross bars 13. Supported in connection with the rearward pair of said cross bars 13 is a magazine structure or frame of any suitable form adapted to provide a holding means for a stack or pile of circulars or similar matter. Said magazine structure or frame includes, at the bottom of its forward end portion, a bottom plate 14, and further includes, at the bottom of its rearward end portion, one or more brackets 15 to which are affixed upwardly and rearwardly inclined and directed retaining spurs 16, preferably in the form of sharp needle-like points. As will be apparent from an inspection of Figure 2 of the drawings, an open space across the bottom of the magazine is provided between said bottom plate 14 and said retaining spurs 16. When a stack or pile of circulars or the like are deposited in the magazine, the front end thereof will be supported on the bottom plate 14 and the rear end upon the sharp spurs 16, the latter piercing a few of the lowermost circulars close to the rearward edge of the same for purposes to be hereinafter more particularly explained.

One of said side plates, as 12, is provided on its external face with a bearing 17 vertically aligned with a bearing 18 on the base 10. Journalled in said bearings 17—18 is a vertical drive shaft 19, which may be driven in any suitable manner and by any suitable means from a power source. Journalled in and between said side plates 12 and 12' is a transverse shaft 20, which is driven from said drive shaft 19 through intermeshing screw gears 21 and 22. Also journalled in and between said side plates 12 and 12', to extend beneath the circular magazine, is a shaft 23 upon which are fixed a pair of circular feed rollers 24. Said shaft 23 is driven from said transverse shaft 20 through intermeshing spur gears 25 and 26. Said feed rollers 24 are provided along a portion of their peripheries

with circumferentially off-set frictional gripper sections 27, preferably made of soft rubber, which at properly timed moments during the rotation of said feed rollers 24 will be carried into engagement with the bottom-most circular of the stack or pile thereof contained in the magazine, and by the frictional contact induced will feed said bottom-most circular forwardly and outwardly from the magazine. Under the impulsion of the feed rollers 24 the bottom-most circular will be torn away from the spurs 16, while the latter nevertheless continue to restrain the outward movement of the circulars immediately above said bottom-most circular, thereby assuring the outward feeding from the magazine of but a single circular at a time. The outwardly moved bottom circular will pass over the bottom plate 14 and beneath the lower edge of a front plate 28 which is spaced sufficiently away from said bottom plate to permit of the outward movement of the fed circulars.

Arranged forwardly of the circular magazine are a pair of mutually impinging circular advancing rolls 29 and 30. The shaft 31 of the lower advancing roll 29 is journaled in fixed bearings to extend between the side plates 12 and 12', and this shaft 31 and its roll 29 are driven through a spur gear 32 which meshes with the spur gear 25 on the transverse shaft 20. The shaft 33 of the upper advancing roll 30 is journaled in spring tensioned bearings 34, whereby the said advancing rolls are pressed together so as to nip and advance circulars delivered thereto. Said advancing rolls 29 and 30 are inter-gearred by gearing 35 so that the upper roll is positively driven by the lower roll. Forwardly of the advancing rolls 29 and 30 are a pair of spaced guide plates 36-37 to form an intermediate guideway 38 through which the circulars are fed by the action of said advancing rolls.

Journaled in a bearing 39, suitably fixed to one of said side plates, as 12, is a journal portion 40 of a rotatable folder spindle 41. Said spindle 41 is disposed transversely between the side plates 12 and parallel to the discharge end or mouth of the guideway 38. Said spindle 41 is provided with a transversely open slot 42 extending longitudinally inward from the free end thereof. Timed rotative impulses or intermittent actuation is imparted to the spindle 41 by suitable power transmission mechanism, such e. g. as the following described or similar or equivalent transmission means. Fixed on said transverse shaft 20 is the driving member 43 of a Geneva gearing which cooperates with the driven member 44 of said Geneva gearing to produce timed intermittent rotation of a transmission gear 45 which is in fixed relation to said driven member 44 so as to rotate therewith. Said driven member 44 of the Geneva gearing and the transmission gear

45 actuated thereby, is rotatably mounted on a stub shaft 46 projecting from the side plate 12. Journaled in the side plate 12, adjacent to the spindle journal portion 40, is a shaft 47, on the outer end of which is fixed a spur gear 48 which meshes with and is driven by the transmission gear 45. Fixed on the inner end of said shaft 47 is a spur gear 49 which meshes with and drives a gear 50 which is affixed to and which in turn imparts motion to the spindle 41.

Slidably mounted upon the rearward end of said folder spindle 41 is an ejector sleeve 51. The said ejector sleeve is capable of reciprocating motion toward and from the free end of said spindle. Timed means is provided for effecting the reciprocatory movement of said ejector sleeve after the spindle has completed the primary folding operations upon the circular in the manner to be hereinafter more particularly set forth. This means for reciprocating the ejector sleeve 51, comprises a lever 52 pivotally supported on a fulcrum bracket 53, which is in turn supported on the inner side of said plate 12. The ejector sleeve 51 is provided at its rearward end with an enlarged annularly channeled shoulder 54, and the free end of said lever 52 is provided with a stud roller 55 which is entered in the channel of said shoulder. Fixed on said transverse shaft 20 is a cam member 56 having a circumferential cam race 57 which operatively receives a stud roller 58 carried by the rearward end of said lever 52. This construction will be best understood from an inspection of Figure 2 of the drawings, and it will be obvious that the cam member 56 will function to oscillate the lever 52 at proper times to in turn effect the desired reciprocation of the ejector sleeve 51.

Suitably supported in straddling relation to the folder spindle 41 is a circular support or cradle 59.

Mounted in connection with the base 10 so as to be opposed to the free end of the folder spindle 41, is a supporting frame work in which is mounted an arrangement of folding rolls and creasing or compression rolls adapted to receive and operate upon circulars discharged from the folder spindle 41, and further adapted to deliver the folded circulars in position to be inserted with accompanying goods or articles into a carton or other container adapted for the reception of said goods or articles. This frame-work may consist in a pair of spaced apart standards 60 of suitable design. Journaled in said standard 60 at one end, and in a suitable bearing 61 mounted on the side plate 12' at the other end, is a transmission shaft 62 which is driven from the transmission shaft 20 through intermeshing screw gears 63 and 64. Fixed on said shaft 62, so as to be disposed between the standard 60, is one of a pair of folding rolls, viz, the roll 65 and the roll 68.

Said roll 68 is mounted on a shaft 67 journaled in spring pressed bearings 66 supported by the standard 60. The shafts 62 and 67 are intergeared together by gears 69 and 70, so that the said folding rolls 65 and 68 are rotated respectively in opposite directions. It will be noted that the spring-pressed bearings 66 urge the roll 68 toward the roll 65 so that said rolls will nip circulars transferred thereto from the folder spindle 41. The nip of the rolls 65 and 68 is aligned with the slot of the folder spindle 41 and is disposed adjacent to the free end of the latter. Each folding roll 65 and 68 is provided, in transverse disposition across its circumference, with a cut-away portion or channel 71. At certain moments in the rotation of said folding rolls said cut-away portions 71 will be brought in opposition to each other, as shown in Figure 3, thus providing a receiving mouth 72 intermediate the rolls and into which the end of a circular ejected from the folder spindle may pass prior to nipping of such circular by the initial nipping margins 73 of the roll surfaces.

Mounted in the standard 60, below the folding rolls 65 and 68, are one or more pairs of combined creasing and feed rollers 74—75, the roller or rollers 74 are mounted on shafts 76 and are positively driven through gearing 77 from the gear 69 of the shaft 62. The roller or rollers 75 may be mounted to yieldably bear against the roller or rollers 74 and will be also driven by the gearing 77. Arranged intermediate the folding rolls 65 and 68 and the adjacent creasing and feed rollers 74—75, as well as between and beyond the rollers 74—75 are spaced plates 78 disposed to provide an intermediate guide-way 79.

When the circular folding mechanism is incorporated as a part of a cartoning or other form of packaging or wrapping machine the guide-way 79 may be disposed so as to deliver the folded circulars in front of a box or carton C suitably supported and disposed in a run-way R, through which the said boxes or cartons are supplied. Suitable means, such as a conveyor A may be employed to carry articles, such as paste tubes T, to be deposited in the boxes or cartons C, and so that the articles are brought into alignment with the latter and in front of the folded circulars. A properly timed plunger P may be utilized to push an article T toward and into the box or carton C, such movement of the article T being utilized to engage a circular 100 and propel the same with the article into the box or carton C. In such case the end 80 of the guideway and the edge of a supporting plate 81 may be utilized to fold back the free ends of the circular 100 over the sides of the article T so that the circular will wrap lengthwise around the article and enter the carton or box therewith. This latter arrangement

will be best understood from an inspection of Figure 3 of the drawings.

In the use and operation of the novel circular folding mechanism of this invention, the magazine is supplied with a stack of circulars desired to be folded. When the stack of circulars is deposited in the magazine, the forward end of the stack rests upon the bottom plate 14, and the rearward end thereof rests upon the spurs 16. Said spurs 16 pierce the lowermost circulars. The weight of the stack of circulars presses the bottom-most circular toward the feed rollers 24.

When power is transmitted to the mechanism through the shaft 19, the feed rollers 24 are caused to rotate. During each complete revolution of the feed rollers 24, the frictional gripper sections 27 will be timed to move into engagement with the bottom-most circular, so as to frictionally grip the same and propel it forwardly and outwardly from the bottom of the magazine. The forward thrusting pressure exerted by the gripper sections 27 of the rollers 24 tends to tear away the bottom-most circular from the spurs 16, while said spurs nevertheless tend to hold back the circulars immediately above said bottom-most circular. The forward movement thus imparted to the bottom-most circular carries its leading end to and between the advancing rollers 29 and 30, the rotation of which causes the same to nip and feed forward the ejected circular through the guide space 38 between the guide plates 36 and 37. Since the guide space 38 is aligned opposite the slot 42 of the folder spindle 41 (which slot 42 is disposed in transverse horizontal plane when the spindle is at rest), the circular will be moved forwardly through said slot 42 with its leading end supported by the cradle 59. The circular will thus be disposed in extension through the folder spindle 41, so as to project laterally from opposite sides thereof in the manner indicated in Figure 5 of the drawings.

By the time the circular has thus been delivered to the folder spindle 41, the Geneva gearing 43—44 functions to transmit motion to the folder spindle 41 by means of the intermediate transmission mechanism which has already been above described. The folder spindle 41 is thus caused to rotate, and in so doing tends to roll upon itself the oppositely projecting portions of the circular, whereby the latter is caused to take a substantially tubular formation, as indicated in Figure 6 of the drawings.

The circular having thus been wound around and upon the folder spindle 41, owing to the intermittent operation of the Geneva gearing, the said spindle comes to rest in normal initial position. After having thus come to rest the transmission mechanism, including the cam member 56, is timed to actuate the lever 52, whereby the ejector sleeve 51

is caused to slide forwardly on the folder spindle 41 and against the rear end of the circular wound thereupon. This action of the ejector sleeve 51 slides outwardly and off of the free end of the folder spindle 41 the outer end portion of the wound circular, so that said end portion is entered within the receiving mouth 72 formed by the cut-away portions 71 of the folding rolls 65 and 68. The folding rolls 65-68 are disposed in a normal initial stopped position with their cut-away portions 71 opposed to the end of the folder spindle 41, so that the receiving mouth 72 formed thereby stands initially open, as shown in Figure 3 of the drawings. The transmission mechanism for actuating the folding rolls 65 and 68 is so arranged that it functions to effect operation of these rolls subsequent to the delivery of the wound circular into the receiving mouth formed in connection therewith. It follows, therefore, that, upon rotation of said folding rolls 65 and 68, the nipping margins 73 thereof will first move toward each other and finally meet and grip the inserted end of the wound circular, whereupon the continued rotation of said folding rolls will flatten out the wound circular into the folded form shown in Figure 7. As the circular is moved onward by the operation of the folding rolls, so as to leave the same in flattened folded condition, it is guided downwardly through the guideway 79, and is thereupon engaged or nipped by the feed rollers 74 and 75, so as to be carried downwardly intermediate the tube T and carton C, so that, as the tube T is thrust forwardly into the carton C, the circular is folded lengthwise around the same to pass into the carton therewith, all as has already been adverted to.

From this brief description of the operation by which the circulars are fed from the magazine rolled and then flattened into folded form, it will be understood that a very efficient and rapid handling of the circulars may be obtained in an automatic and successive manner. The circular feeding and folding mechanism may be easily timed to cause its operation to synchronize with the operation of article cartoning mechanism, and consequently said circular folding mechanism may be satisfactorily incorporated with and as a part of a cartoning machine. It will be understood, however, that the circular folding mechanism per se may also be operated as an independent unit, when the operation of circular folding is alone desired.

While we have shown in the drawings and have above described one embodiment of the circular folding mechanism with an arrangement of feed rollers adapted to deliver circulars vertically, it will nevertheless be understood that the circulars may be delivered in other positions by any desired arrange-

ment of delivery means disposed beyond the folding rolls 65 and 68; and in fact where circular folding is alone desired, the delivery rolls 74 and 75 and the cooperating guideway 78 may be eliminated.

It will also be understood that forms and designs of circular feeding means adapted to successively deliver circulars to the folder spindle 41 other than that shown and described may be provided, and that in its broader aspects this invention, as hereinafter claimed, is not to be considered as limited to the specific circular delivery means herein described and illustrated in the drawings.

We have shown and described one specific embodiment of the circular folding mechanism, but it will be obvious that many changes could be made in the described construction and many apparently widely different embodiments of this invention could be made without departing from the scope thereof; it is intended, therefore, that all matter contained in the above description or shown in the accompanying drawings shall be interpreted as illustrative and not in a limiting sense.

We claim:—

1. A circular folding mechanism, comprising a rotatable folder spindle having a transverse slot open at the free end thereof, said slot being adapted to receive a circular in flat-wise extension therethrough, means to rotate said spindle to wind the circular thereupon, an ejector means to move the wound circular endwise from said spindle, and means operative to flatten the wound circular into a folded form adapted to receive and engage the latter when it is moved from said spindle.

2. A circular folding mechanism, comprising an intermittently rotatable folder spindle having a transverse slot open at the free end thereof, means to successively deliver circulars from a supply thereof to said spindle in flatwise extension through the slot of the latter and while the spindle is stationary whereby on rotation of said spindle a circular is wound thereupon, an ejector means to move a wound circular endwise from said spindle, and means operative to flatten a wound circular into a folded form adapted to receive and engage the latter when it is moved from said spindle.

3. A circular folding mechanism, comprising a rotatable folder spindle having a transverse slot open at the free end thereof, said slot being adapted to receive a circular in flat-wise extension therethrough, means to rotate said spindle to wind the circular thereupon, an ejector means to move the wound circular endwise from said spindle, and a pair of folding rolls opposed to the free end of said spindle to receive and flatten into folded form a wound circular moved into engagement therewith from said spindle.

4. A circular folding mechanism, compris-

means operative to flatten the wound circular into a folded form adapted to receive and  
 ing a rotatable folder spindle having a transverse slot open at the free end thereof, said  
 5 slot being adapted to receive a circular in flatwise extension therethrough, means to rotate said spindle to wind the circular thereupon, an ejector means to move the wound circular endwise from said spindle, a pair of  
 10 folding rolls opposed to the free end of said spindle, said folding rolls having transverse cutaway portions in their circumferential faces adapted to cooperate to form a receiving mouth into which an end of a wound  
 15 circular may be entered when moved from said spindle, and means to rotate said rolls to pass an entered circular therebetween and thus flatten the same into a folded form.

5. A circular folding mechanism, comprising an intermittently rotatable folder spindle having a transverse slot open at the free end thereof, means to successively deliver circulars from a supply thereof to said spindle in flatwise extension through the slot of the  
 25 latter and while the spindle is stationary whereby on rotation of said spindle a circular is wound thereupon, an ejector means to move a wound circular endwise from said spindle, and a pair of folding rolls opposed to the free  
 30 end of said spindle to receive and flatten into folded form a wound circular moved into engagement therewith from said spindle.

6. A circular folding mechanism, comprising an intermittently rotatable folder spindle having a transverse slot open at the free end thereof, means to successively deliver circulars from a supply thereof to said spindle in flatwise extension through the slot of the  
 40 latter and while the spindle is stationary whereby on rotation of said spindle a circular is wound thereupon, an ejector means to move a wound circular endwise from said spindle, and a pair of folding rolls having transverse cutaway portions in their circumferential  
 45 faces adapted to cooperate to form a receiving mouth into which an end of a wound circular may be entered when moved from said spindle, and means to rotate said rolls to pass an entered circular therebetween and thus  
 50 flatten the same into a folded form.

7. A circular folding mechanism, comprising a rotatable folder spindle having a transverse slot open at the free end thereof, said slot being adapted to receive a circular in flatwise extension therethrough, means to intermittently rotate said spindle, timed means to deliver a circular from a supply thereof to said spindle in flatwise extension through the slot of the latter and while the spindle is stationary whereby on rotation of said spindle  
 60 said circular is wound thereupon, an ejector sleeve slidable on said spindle, means for reciprocating said ejector, timed means for actuating said reciprocating means whereby  
 65 said ejector is operated to move a wound circular

from said spindle after completion of the winding thereof on said spindle, and engage the latter when it is moved from said spindle.

8. A circular folding mechanism, comprising a rotatable folder spindle having a transverse slot open at the free end thereof, said slot being adapted to receive a circular in flatwise extension therethrough, means to intermittently rotate said spindle, timed means to deliver a circular from a supply thereof to said spindle in flatwise extension through the slot of the latter and while the spindle is stationary whereby on rotation of said spindle  
 80 said circular is wound thereupon, an ejector sleeve slidable on said spindle, means for reciprocating said ejector, timed means for actuating said reciprocating means whereby  
 85 said ejector is operated to move a wound circular from said spindle after completion of the winding thereof on said spindle, and a pair of folding rolls opposed to the free end of said spindle to receive and flatten into folded form a wound circular ejected from  
 90 said spindle.

9. A circular folding mechanism, comprising a rotatable folder spindle having a transverse slot open at the free end thereof, said slot being adapted to receive a circular in flatwise extension therethrough, means to intermittently rotate said spindle, timed means to deliver a circular from a supply thereof to said spindle in flatwise extension through the slot of the latter and while the spindle is stationary whereby on rotation of said spindle  
 100 said circular is wound thereupon, an ejector sleeve slidable on said spindle, means for reciprocating said ejector, timed means for actuating said reciprocating means whereby  
 105 said ejector is operated to move a wound circular from said spindle after completion of the winding thereof on said spindle, a pair of folding rolls having transverse cutaway portions in their circumferential faces adapted to cooperate to form a receiving mouth into  
 110 which an end of a wound circular may be entered when ejected from said spindle, and means to rotate said rolls to pass an entered circular therebetween and thus flatten the same into folded form.

In testimony, that we claim the invention set forth above we have hereunto set our hands this 19th day of December, 1928.

GEORGE I. HOHL.

HARRY L. EVANS.

70

75

80

85

90

95

100

105

110

115

120

125

130