

J. A. McKinstry,

Miter Box.

N<sup>o</sup> 59,046.

Patented Oct. 23, 1866.

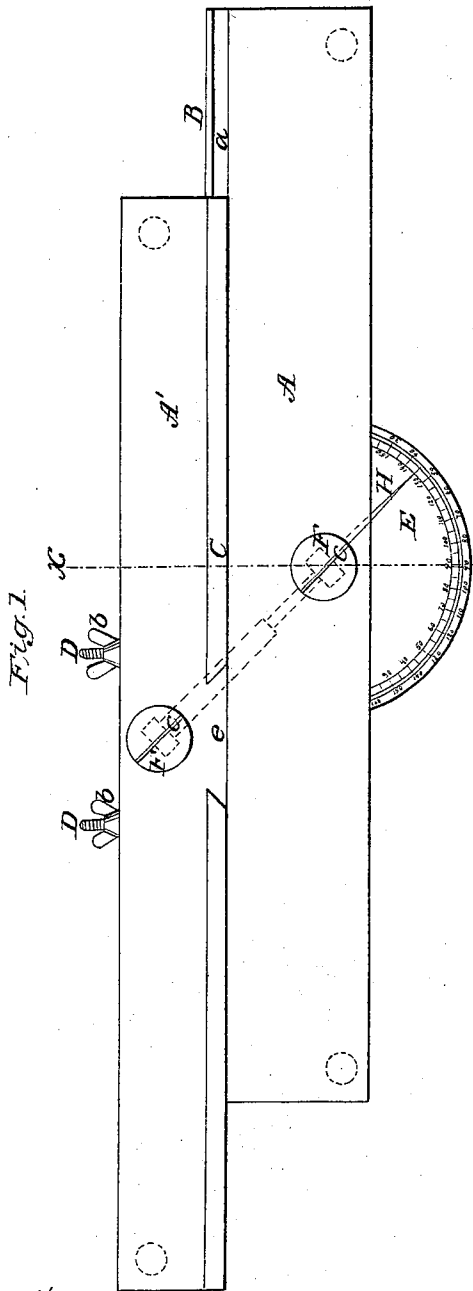

Fig. 1.

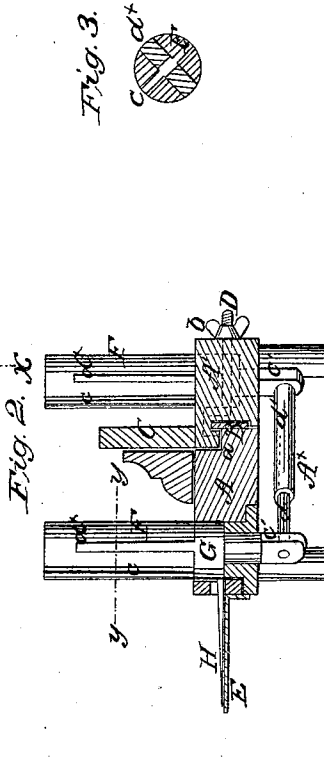

Fig. 2. X

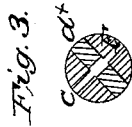

Fig. 3.

Witnesses:  
T. A. Jackson.  
Wm. Erwin.

Inventor:  
J. A. McKinstry  
Per Wm. C. Erwin.

# UNITED STATES PATENT OFFICE.

J. A. MCKINSTRY, OF MONSON, MASSACHUSETTS.

## IMPROVEMENT IN MITER-BOXES.

Specification forming part of Letters Patent No. 59,016, dated October 23, 1836.

*To all whom it may concern:*

Be it known that I, J. A. MCKINSTRY, of Monson, in the county of Hampden and State of Massachusetts, have invented a new and Improved Miter-Box; and I do hereby declare that the following is a full, clear, and exact description thereof, which will enable those skilled in the art to make and use the same, reference being had to the accompanying drawings, forming part of this specification, in which—

Figure 1 is a plan or top view of my invention; Fig. 2, a transverse vertical section of the same, taken in the line *x x*, Fig. 1; Fig. 3, a horizontal section of a portion of the same, taken in the line *y y*, Fig. 2.

Similar letters of reference indicate corresponding parts.

This invention relates to a new and improved miter-box of that class in which the saw-guides are adjustable to admit of the moldings or other articles or stuff to be operated upon being cut or sawed to any desired angle.

The object of the invention is to obtain a miter-box of the class specified which will be simple in construction, capable of having its saw-guides adjusted with facility and great accuracy, and also capable of having said guides renewed without any difficulty when worn by use.

The bed of the device is composed of two parallel parts, A A', connected together in such a manner that they may be moved or adjusted longitudinally. This connection is arranged in this particular instance as follows: The rear or inner edge of the part A of the bed-piece has a metal plate, B, secured to it by screws or otherwise, said plate extending the whole length of A, and the latter having a rabbet, *a*, made in its upper edge, which rabbet extends down a little below the upper edge of plate B to receive the lower part of a guide, C, which is attached to the inner edge of the part A' of the bed-piece, as shown clearly in Fig. 2. This connection, it will be seen, admits of the longitudinal adjustment of the parts A A', and said parts are secured at any desired point within the scope or range of their movement by means of clamps composed of rods D D, which pass transversely through the part A', and are formed with hooks at their inner ends to catch over the top of plate B, the outer

ends of the rods D having screw-threads cut on them to receive nuts *b*, by screwing up which the two parts A A' may be clamped firmly together. (See Fig. 2, in which the clamps are chiefly shown by dotted lines.)

To the outer edge of the part A of the bed-piece there is secured a horizontal semicircular graduated plate, E, and in each part A A' of the bed-piece there is inserted an upright post, F, which have saw-kerfs *c* made vertically in them to receive the saw-blade and serve as guides for the same. These posts F are constructed of wood and are fitted on metallic uprights G, the lower portions of which are of cylindrical form and are fitted in the parts A A' of the bed-piece, and have pendent lips or lugs *c'*, which extend down below the parts A A'. The upper parts, *a*<sup>x</sup>, of the uprights G are made flat and are fitted in slots in the posts. (See Figs. 2 and 3.) These flat parts of the uprights are slotted vertically to receive the saw, said slots being sufficiently wide to prevent the saw-teeth coming in contact with them.

By this arrangement it will be seen that the posts E may be readily detached from the metallic uprights and new ones applied when necessary. This frequently is necessary, as the teeth of the saw gradually widen the kerfs *c c* in the posts F, so that they will not serve as proper guides for the saw.

The two posts F F are connected by means of a telescopic or expanding rod, A<sup>x</sup>, composed of two parts, *d d'*, which are attached to the lips or lugs *c'*, the part *d'*, which is attached to the lip or lug of the upright G of one post, being tubular and receiving the rod *d*, which is attached to the lip or lug of the upright of the other post. (See Fig. 2.) This telescopic or extension tube performs an important function, to wit: it connects the two posts F F, and in the adjustment of the parts A A' keeps the the saw-kerfs *c* of the two posts F F in line with each other by causing the uprights G to turn simultaneously and equally in the same direction.

The guide C is notched or divided at its center, so as to leave a space, *e*, in line with the posts F F, for the saw to work through; and the molding or other article to be sawed is placed against the guide C and the parts A A' moved longitudinally, so as to bring the saw-kerfs *c c* of the posts F F at the angle re-

quired for sawing the molding or stuff; and this angle, be it greater or less, is obtained with the greatest facility and exactness by an index, H, projecting from the upright G of the post of the part A of the bed-piece, said index extending over the graduated plate E. (See more particularly Fig. 1.)

When the parts A A' are adjusted as desired, the nuts *b*, which were previously unscrewed or relaxed, are screwed up, and the parts A A' thereby firmly secured in position. The saw is then placed in the kerfs *c c* of the posts F F, and the molding or other article sawed or cut through at the proper or desired angle.

Having thus described my invention, what I claim as new, and desire to secure by Letters Patent, is—

The miter-box the parts of which are composed of the adjustable plates A A', guide C, plate B, hooked rods D, graduated plate E, guide-posts F, uprights G, and expanding rod A<sup>x</sup>, when arranged and operating substantially as described, for the purpose specified.

J. A. MCKINSTRY.

Witnesses:

S. C. CHANDLER,  
AUSTIN FULLER.