



(12) **United States Patent**
Suzuki et al.

(10) **Patent No.:** **US 10,148,140 B2**
(45) **Date of Patent:** **Dec. 4, 2018**

(54) **MOTOR**

(71) Applicant: **ASMO CO., LTD.**, Shizuoka-ken (JP)
(72) Inventors: **Takumi Suzuki**, Toyohashi (JP); **Yuuji Yamashita**, Toyohashi (JP)
(73) Assignee: **DENSO CORPORATION**, Kariya, Aichi-pref. (JP)

(*) Notice: Subject to any disclaimer, the term of this patent is extended or adjusted under 35 U.S.C. 154(b) by 397 days.

(21) Appl. No.: **14/162,548**

(22) Filed: **Jan. 23, 2014**

(65) **Prior Publication Data**
US 2014/0210306 A1 Jul. 31, 2014

(30) **Foreign Application Priority Data**
Jan. 28, 2013 (JP) 2013-013341
Jan. 28, 2013 (JP) 2013-013346

(51) **Int. Cl.**
H02K 1/18 (2006.01)
H02K 5/15 (2006.01)

(52) **U.S. Cl.**
CPC **H02K 1/185** (2013.01); **H02K 5/15** (2013.01)

(58) **Field of Classification Search**
CPC H02K 1/185; H02K 5/15; H02K 1/18; H02K 1/182; H02K 1/187
USPC 310/216.134, 216.049, 216.016, 216.009, 310/216.055, 216.058, 216.129, 216.011, 310/217, 413, 432, 90, 89, 254.1, 310/216.004, 216.015, 216.089
See application file for complete search history.

(56) **References Cited**

U.S. PATENT DOCUMENTS

1,771,475 A * 7/1930 Wright H02K 1/185 310/162
4,886,990 A * 12/1989 Barker D06F 37/304 310/172
5,640,064 A * 6/1997 Boyd, Jr. H02K 1/165 29/598

(Continued)

FOREIGN PATENT DOCUMENTS

CN 101005216 A * 7/2007 H02K 1/1185
CN 102290879 A 12/2011

(Continued)

OTHER PUBLICATIONS

English translation for JP 2002-272025; Takahama et al.; Japan; Sep. 2002.*

(Continued)

Primary Examiner — Bernard Rojas
Assistant Examiner — Ahmed Elnakib
(74) *Attorney, Agent, or Firm* — Christensen, Fonder, Dardi & Herbert PLLC

(57) **ABSTRACT**

A motor includes a stator having a stator core, a first frame and a second frame, which are arranged on two axial sides of the stator core, a coupling member, which couples the first and second frames at a radially outer side of the stator while applying a holding load to the first and second frames in the axial direction, and a rotor, which is arranged at a radially inner side of the stator. The stator core includes a held portion that projects toward a radially outer side from a main circumferential portion of the stator core. The first and second frames hold, in between, at least the held portion of the stator core in the axial direction.

15 Claims, 8 Drawing Sheets

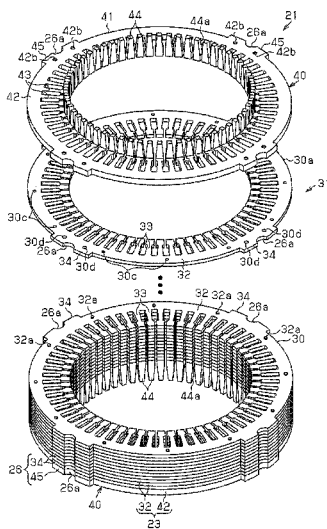

(56)

References Cited

U.S. PATENT DOCUMENTS

6,242,836 B1 * 6/2001 Ishida H02K 3/345
 29/596
 6,337,530 B1 * 1/2002 Nakamura H02K 5/15
 310/216.044
 6,348,753 B1 * 2/2002 Sakai H02K 5/15
 310/191
 2001/0036414 A1 * 11/2001 Makino H02K 1/185
 417/312
 2006/0066172 A1 * 3/2006 Takeuchi H02K 21/222
 310/52
 2006/0181173 A1 * 8/2006 Takahashi H02K 1/16
 310/216.011
 2006/0197402 A1 9/2006 Gomyo et al.
 2008/0061653 A1 * 3/2008 Sagara H02K 1/148
 310/254.1
 2008/0106167 A1 * 5/2008 Gomyo H02K 1/146
 310/216.016
 2009/0200887 A1 * 8/2009 Okamoto H02K 1/185
 310/195
 2011/0006620 A1 * 1/2011 Kawasaki H02K 1/148
 310/48
 2012/0153768 A1 * 6/2012 Sanji H02K 15/024
 310/216.009

2012/0326554 A1 * 12/2012 Kinpara H02K 1/16
 310/216.004
 2013/0002086 A1 * 1/2013 Kaiser H02K 1/16
 310/216.009

FOREIGN PATENT DOCUMENTS

CN 202260679 U 5/2012
 EP 0793332 * 9/1997
 JP H07-284257 A 10/1995
 JP 2002-272025 A 9/2002
 JP 2011-239533 A 11/2011
 WO WO 2005/022718 * 3/2005
 WO 2008/012880 A1 1/2008

OTHER PUBLICATIONS

English translation of JP 2002-272025; Takahara et al. Japan. Sep. 2002.*
 English translation of JP 2002-272025; Takahara et al. Sep. 2002.*
 English translation of JP 2002272025; Sep. 2002.*
 English translation of JP 2011004457; Jan. 2011.*
 Japanese Office Action of JP 2013-013346 dated May 31, 2016.

* cited by examiner

Fig. 5

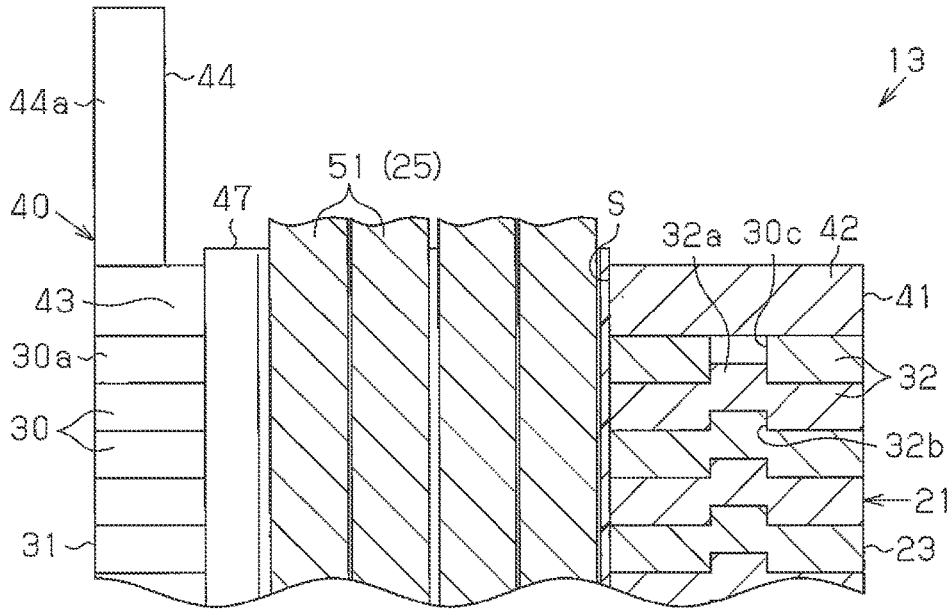

Fig. 6

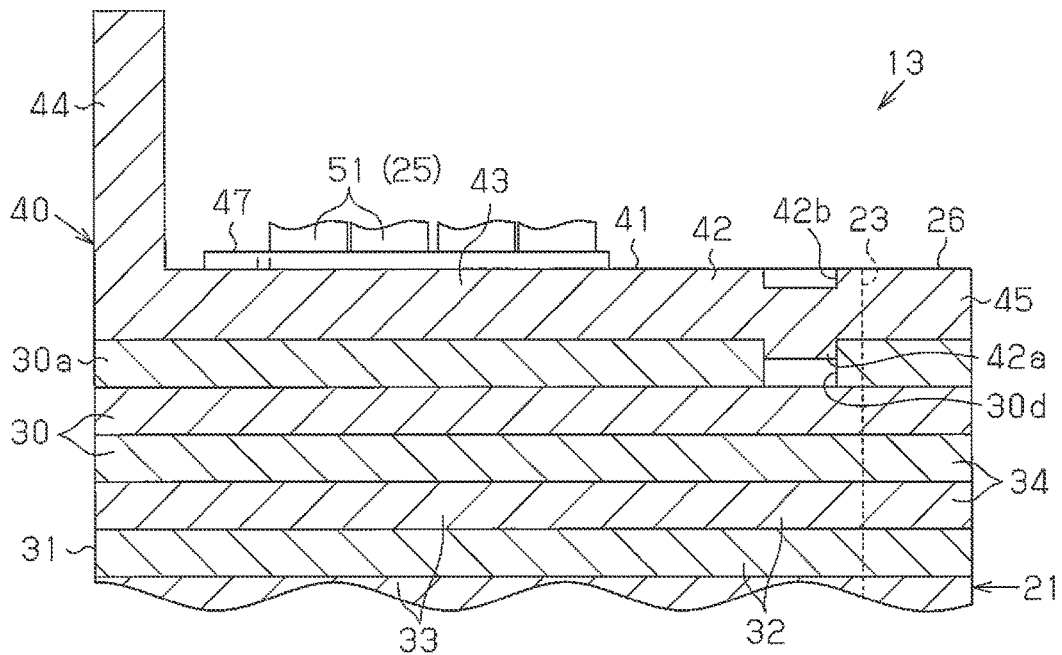

Fig.7

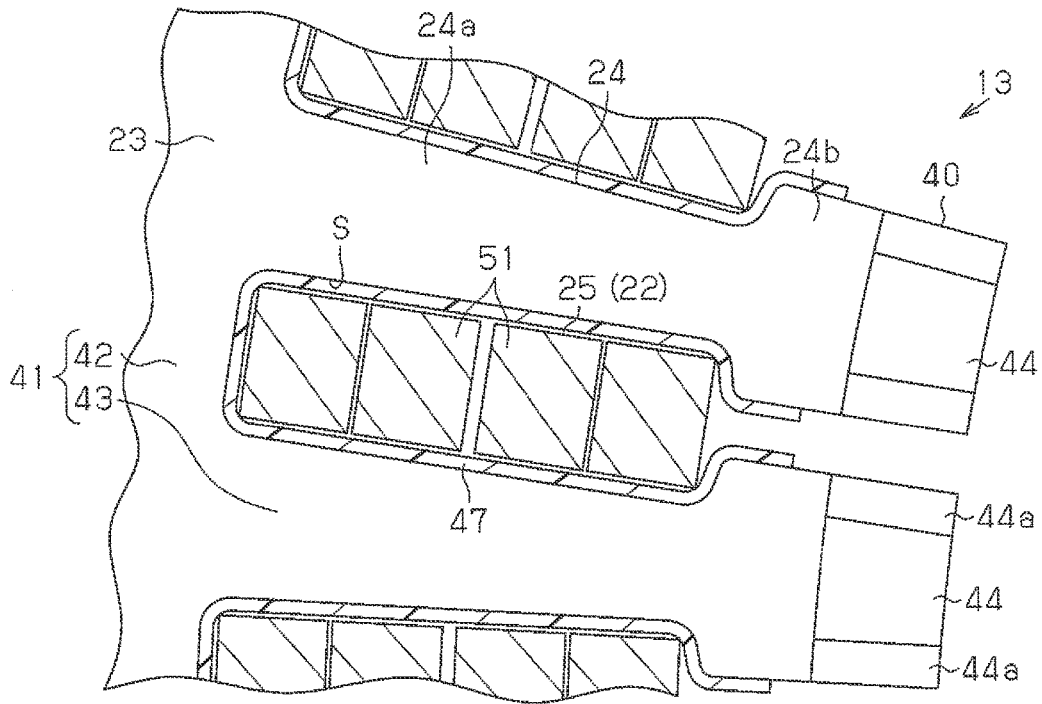

Fig.8

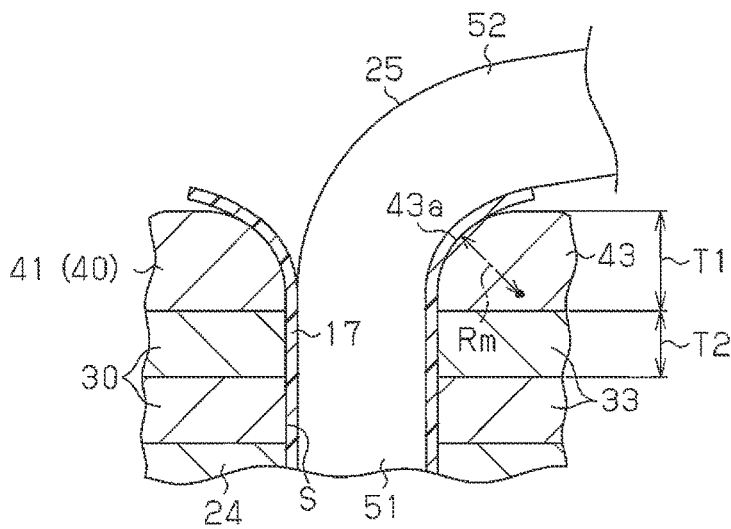

Fig.10

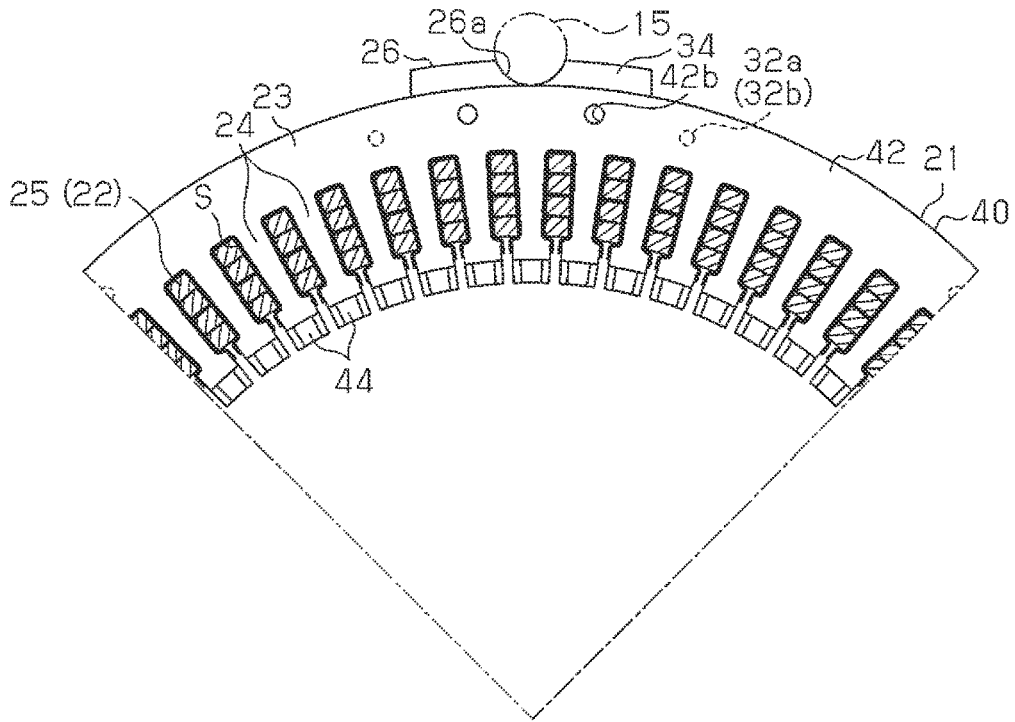

Fig.11

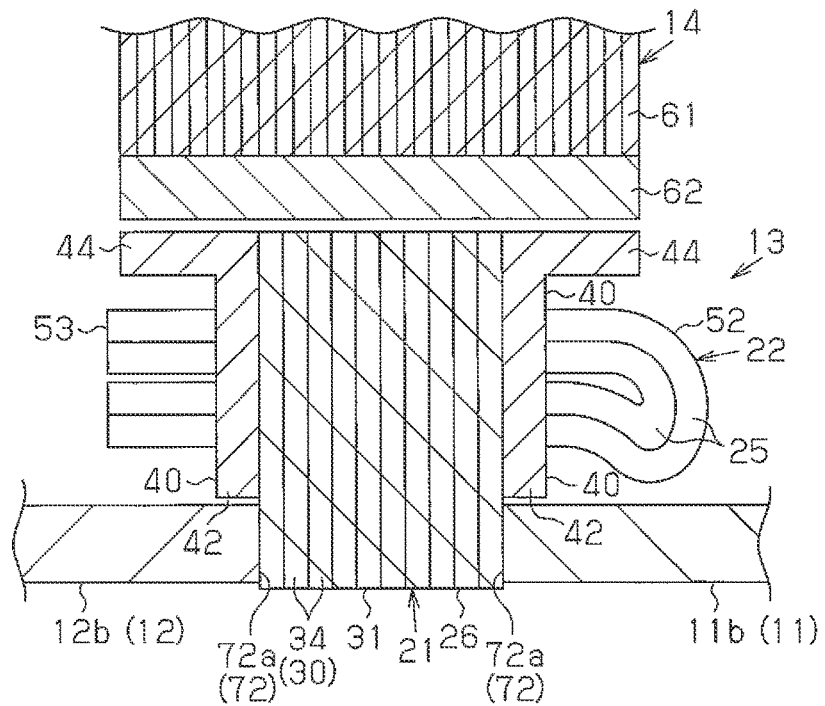
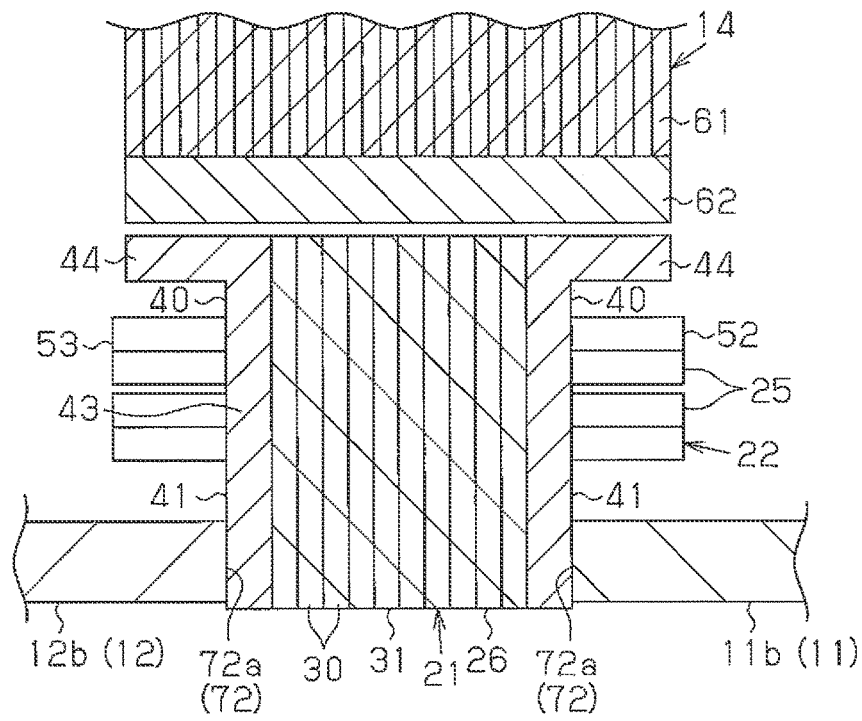

Fig. 12



1

MOTOR

BACKGROUND OF THE INVENTION

The present invention relates to a motor.

Japanese Laid-Open Patent Publication No. 2011-239533 describes a motor including two frames coupled to two axial sides of a stator to hold the stator in between in the axial direction. The stator includes a stator core, a plurality of teeth extending toward a radially inner side from a main circumferential portion of the stator core, and an armature winding attached to the teeth. The two frames are coupled to each other by coupling members, such as through bolts, while holding the main circumferential portion of the stator core in between in the axial direction. A rotor, which is arranged at the radially inner side of the stator, is rotatably supported by bearings coupled to the two frames. The motor of such a structure allows for the main circumferential portion of the stator core to be exposed to the outside from between the frames so that heat is easily released from the stator.

SUMMARY OF THE INVENTION

In the motor described above, the coupling members coupling the frames are located at the radially outer side of the main circumferential portion of the stator that is held between the frames. Accordingly, a holding load of the coupling members and a reaction force the frame receives from the main circumferential portion of the stator core form a force couple. When the holding load is large, the frame may be deformed.

It is an object of the present invention to provide a motor capable of limiting deformation of the frames that hold the stator core in between.

One aspect of the present invention is a motor including a stator, a first frame, a second frame, a coupling member that couples the first and second frames, and a rotor rotatably supported by the first and second frames and arranged at the radially inner side of the stator. The stator includes a stator core, a plurality of teeth extending toward a radially inner side from a main circumferential portion of the stator core, and an armature winding attached to the teeth. The stator core includes a held portion that projects toward a radially outer side from the main circumferential portion. The first frame and the second frame are respectively arranged on two axial sides of the stator core to hold, in between, at least the held portion of the stator core in the axial direction. The first frame and the second frame are formed so that the main circumferential portion of the stator core is exposed to the exterior from between the first frame and the second frame. The coupling member couples the first and second frames at the radially outer side of the stator while applying a holding load to the first and second frames in the axial direction.

BRIEF DESCRIPTION OF THE DRAWINGS

The invention, together with objects and advantages thereof, may best be understood by reference to the following description of the presently preferred embodiments together with the accompanying drawings in which:

FIG. 1 is a schematic cross-sectional view showing one embodiment of a motor;

FIG. 2 is a plan view of a stator in the motor of FIG. 1;

FIG. 3 is a front view illustrating a rotor opposing portion of a magnetic plate in the motor of FIG. 1;

2

FIG. 4 is an exploded perspective view of a stator core in the motor of FIG. 1;

FIG. 5 is a cross-sectional view taken along line 5-5 in FIG. 2;

FIG. 6 is a cross-sectional view taken along line 6-6 in FIG. 2;

FIG. 7 is an enlarged plan view showing the motor of FIG. 1 in part;

FIG. 8 is a schematic cross-sectional view showing a bent portion of a segment conductor of FIG. 7;

FIG. 9 is a schematic cross-sectional view of a portion of the motor shown in FIG. 1;

FIG. 10 is an enlarged plan view showing a motor of a further example in part;

FIG. 11 is an enlarged schematic cross-sectional view showing, in part, the motor of FIG. 10; and

FIG. 12 is an enlarged schematic cross-sectional view showing a motor of another example.

DETAILED DESCRIPTION OF THE PREFERRED EMBODIMENTS

One embodiment of a motor will now be described.

As shown in FIG. 1, a motor 10 of the present embodiment includes a rear frame 11 and a front frame 12, an annular stator 13, which is held between the rear frame 11 and the front frame 12 in the axial direction of the motor 10, and a rotor 14, which is arranged at the radially inner side of the stator 13. The front frame 12 holds an output side (closer to a joint 63, described later) in the axial direction of the motor 10. The rear frame 11 holds the side of the motor 10 opposite to the output side in the axial direction. Through bolts 15 fasten and fix the frames 11 and 12 at positions located at the radially outer side of the stator 13 so that the frames 11 and 12 are not separated from each other.

Frames

The rear frame 11 and the front frame 12 are made from a metal material such as aluminum, steel, and the like. The rear frame 11 includes a substantially disk-shaped main body portion 11a and a cylindrical stator holding portion 11b, which extends in the axial direction of the motor 10 from the peripheral edge of the main body portion 11a. The front frame 12 also has substantially the same structure and includes a substantially disk-shaped main body portion 12a and a circular ring-shaped stator holding portion 12b, which extends in the axial direction of the motor 10 from the circumferential edge of the main body portion 12a. Coaxially arranged bearings 16 and 17 are held at radially middle sections of the main body portions 11a and 12a in the frames 11 and 12. A rotation shaft 18 of the rotor 14 is axially supported by the bearings 16 and 17.

Fastening portions 11c and 12c are formed in the main body portions 11a and 12a of the frames 11 and 12 extending toward the radially outer side from a plurality of locations (e.g., two locations) in the peripheral edge. In the present embodiment, two fastening portions 11c are arranged at positions facing each other and separated by 180 degrees in the circumferential direction. Further, the two fastening portions 12c are arranged at positions facing each other and separated by 180 degrees in the circumferential direction. Thus, the number of the fastening portions 11c in the rear frame 11 is the same as the number of the fastening portions 12c in the front frame 12, and the fastening portions 11c and 12c are faced to each other in the axial direction of the rotation shaft 18. The through bolts 15 are fastened to paired ones of the fastening portions 11c and 12c so that the frames 11 and 12 are fixed to each other holding the stator 13 in

between. The fastening portions **11c** and **12c** are each located at the axially outer side of the stator holding portions **11b** and **12b**.

Stator

The stator **13** includes an annular stator core **21**, which is held between the stator holding portions **11b** and **12b** of the frames **11** and **12**, and armature windings **22**, which are attached to the stator core **21**.

As shown in FIGS. **2** and **7**, the stator core **21** includes a cylindrical portion **23** (main circumferential portion), which forms a circumferential region, a plurality of (sixty in the present embodiment) teeth **24** extending toward the radially inner side from the cylindrical portion **23**, and an outer circumferential core projection **26** (held portion) projecting toward the radially outer side from the outer circumferential surface of the cylindrical portion **23**.

Four outer circumferential core projections **26** are formed at equal intervals (intervals of 90 degrees) in the circumferential direction of the cylindrical portion **23**. Each outer circumferential core projection **26** is formed to extend in the axial direction of the cylindrical portion **23** from one axial end to the other axial end. An engagement groove **26a** (engagement recess), which is curved inward and extends in the axial direction, is formed in the end face at a circumferentially central part of the outer circumferential core projection **26**.

Two of the outer circumferential core projections **26** that are located at opposite sides and separated from each other by 180 degrees are located at the same positions in the circumferential direction as the two through bolts **15**. Each through bolt **15** is fitted into the engagement groove **26a** formed in one of the outer circumferential core projections **26**. The engagement groove **26a** is engaged with the through bolt **15** in the circumferential direction. This engagement restricts free rotation of the stator core **21**.

Each tooth **24** includes a tapered radial extending portion **24a**, in which the circumferential width decreases toward the radially inner side, and a wide portion **24b**, which is formed at a distal end (radially inner end) of the radial extending portion **24a** and has a greater circumferential width than the radial extending portion **24a**. Two circumferential end faces of the radial extending portion **24a** are flat and extend parallel to the axis of the rotation shaft **18**. Further, an end face of one radial extending portion **24a** is parallel to the end face of an adjacent one of the radial extending portions **24a** in the circumferential direction.

A void between adjacent ones of the teeth **24** forms a slot **S**, which accommodates segment conductors **25** of the armature windings **22**. That is, the slot **S** is formed by circumferential side surfaces of adjacent teeth **24** and the inner circumferential surface of the cylindrical portion **23** between the teeth **24**. In the present embodiment, the teeth **24** are formed so that the circumferential end faces are parallel in adjacent ones of the radial extending portions **24a** in the circumferential direction and so that each slot **S** is formed to be substantially rectangular as viewed shape when seen in the axial direction. Each slot **S** extends through the stator core **21** in the axial direction and opens toward the radially inner side. The number of slots **S** formed in the stator core **21** is the same as the number (sixty in the present embodiment) of teeth **24**.

Stator Core

The stator core **21** having the shape described above is formed by stacking and integrating a plurality of steel plates.

In detail, as shown in FIG. **4**, the stator core **21** includes a main core **31** and magnetic plates **40** (auxiliary cores) fixed to two axial ends of the main core **31**. The main core **31** is

formed by stacking, swaging, and integrating a plurality of core sheets **30**, which are pressed and punched out from steel plates, in the axial direction. In the present embodiment, the magnetic plates **40** having identical shapes are each set on one of the two axial sides of the main core **31**.

The core sheets **30** of the main core **31** have identical shapes and are each set so that the plate surface is orthogonal to the axial direction. Each core sheet **30** includes an annular portion **32**, a plurality of tooth formation portions **33** extending toward the radially inner side from the annular portion **32**, and a plurality of projections **34** projecting toward the radially outer side from the annular portion **32**. The core sheets **30** are stacked so that the tooth formation portions **33** are overlapped in the axial direction and the projections **34** are overlapped in the axial direction.

The magnetic plates **40** are formed by undergoing pressing. As shown in FIGS. **2**, **4**, and **7**, each magnetic plate **40** includes a plate-like stacked portion **41** stacked on the core sheet **30** located at one of the two axial ends of the main core **31**. The stacked portion **41** is stacked so as to be parallel and coaxial to the core sheets **30** of the main core **31**. The magnetic plate **40** has a plate thickness **T1** set to be greater than a plate thickness **T2** of each core sheet **30** of the main core **31** (see FIG. **9**).

The stacked portion **41** includes an annular portion **42** axially overlapped with the annular portions **32** of the core sheets **30**, a plurality of tooth formation portions **43** extending toward the radially inner side from the annular portion **42**, and a plurality of projections **45** projecting toward the radially outer side from the annular portion **42**. The annular portion **42**, the tooth formation portion **43**, and the projection **45** of the stacked portion **41** are respectively shaped identically to the annular portion **32**, the tooth formation portion **33**, and the projection **34** of each core sheet **30** as viewed in the axial direction. The magnetic plate **40** is set so that the annular portion **42**, the tooth formation portion **43**, and the projection **45** of the stacked portion **41** are axially overlapped with the annular portion **32**, the tooth formation portion **33**, and the projection **34** of each core sheet **30**.

The annular portions **32** and **42** of the core sheets **30** and the magnetic plates **40** form the cylindrical portion **23** of the stator core **21**. The tooth formation portions **33** and **43** form the teeth **24** of the stator core **21**. The projections **34** and **45** form the outer circumferential core projections **26**. The annular portions **32** and **42**, the tooth formation portions **33** and **43**, and the projections **34** and **45** as viewed in the axial direction are shaped identically to the cylindrical portion **23**, the teeth **24**, and the outer circumferential core projections **26** and will thus not be described in detail.

The radially inner side end (end closer to the rotor **14**) of each tooth formation portion **43** in each magnetic plate **40** forms a rotor opposing portion **44** extending toward the axially outer side (side opposite to the main core). The rotor opposing portion **44** is formed by bending the radially inner side end of the tooth formation portion **43** at a right angle toward the axially outer side. That is, the magnetic plate **40** is formed so that the plate surface of the rotor opposing portion **44** bent toward the axially outer side faces the radial direction. The inner diameter surface of the rotor opposing portion **44** is curved to have the same diameter as the inner diameter of the main core **31** (core sheet **30**). The axial thickness of the stacked portion **41** and the radial thickness of the rotor opposing portion **44** are equal to each other and determined by the plate thickness **T1** of the magnetic plate **40**. The thickness of a bent portion (corner formed by the tooth formation portion **43** and the rotor opposing portion **44**) between the rotor opposing portion **44** and the tooth

formation portion **43** is formed to be thicker than the plate thickness of the rotor opposing portion **44** (i.e., plate thickness **T1** of the magnetic plate **40**).

As shown in FIG. 3, each of the two circumferential sides of each rotor opposing portion **44** defines a side edge **44a** serving as a circumferential side. The side edge **44a** is inclined in the circumferential direction to the axial direction of the rotation shaft **18**. The side edge **44a** is inclined toward the middle of the rotor opposing portion **44** in the circumferential direction at locations closer to the distal end (separated from the main core). Further, the side edges **44a** are formed to be symmetric relative to a center line in the circumferential direction of the rotor opposing portion **44** when the rotor opposing portion **44** is viewed from the radial direction. Thus, the rotor opposing portion **44** is formed so that the circumferential width of the axial basal end (axially inner side) is equal to the circumferential width of the distal end (wide portion **24b**) of the tooth formation portion **43** and the circumferential width decreases toward the axial distal end (axially outer side). This obtains a trapezoidal shape as viewed in the radial direction. The rotor opposing portions **44** are all identically shaped in the present embodiment.

The annular portions **32** of the core sheets **30** are fixed together by swaging dowels into holes of the annular portions **32** that are adjacent in the axial direction. The annular portion **42** in the stacked portion **41** of each magnetic plate **40** is fixed by swaging a dowel into a hole formed in the annular portion **32** of the core sheet **30** located at one of the two axial ends.

As shown in FIGS. 2, 4, and 5, each core sheet **30**, excluding the core sheet **30a** located at one axial end, includes protrusions **32a** (dowels) that protrude in the plate thickness direction and are formed in by performing a pressing process on the annular portion **32**. Twelve protrusions **32a** are formed at equal intervals (30-degree intervals) in the circumferential direction of the annular portion **32**. When the protrusions **32a** are formed, a recess **32b** is formed in the rear side of each protrusion **32a**. In the present embodiment, the protrusions **32a** and the recesses **32b** are formed at locations separated in the circumferential direction from the projections **34** and located at the radially outer sides of predetermined slots **S** (in detail, every five slots **S** in the circumferential direction). The protrusions **32a** are pressed and fitted (dowel-swaged) into the recesses **32b** of the adjacent core sheet **30** in the axial direction. The core sheet **30a** at one axial end includes a plurality of through holes **30c**, into which the protrusions **32a** of the adjacent core sheet **30** are press-fitted and fixed. Thus, the protrusions **32a** and the recesses **32b** form swaged portions for the core sheets **30**, and the core sheets **30** are integrally fixed by the swaged portions to form the main core **31**.

As shown in FIGS. 2, 4, and 6, the annular portion **42** (stacked portion **41**) of each magnetic plate **40** is pressed to form the protrusions **42a** (dowels) that project toward the main core **31** (toward the core sheet **30**) in the plate thickness direction. When forming the protrusions **42a**, the recesses **42b** are formed in the opposite side of the protrusions **42a**. The protrusions **42a** are formed in the annular portion **42** at the radially inner side of the projections **45** and at the same circumferential positions as the projections **45**. In the present embodiment, a total of eight protrusions **42a**, two for each projection **45**, are formed. At the radially inner side of each projection **45**, a protrusion **42a** is formed at a position separated from each of the two circumferential sides of the engagement groove **26a**. That is, the protrusions **42a** are formed at locations where the formation of the projections **45** increases the radial width. The protrusions

42a limit increases in the magnetic resistance. The distance from the axis of the stator core **21** to the center of each protrusion **42a** is set to be greater than the distance from the axis of the stator core **21** to the center of each protrusion **32a**.

The core sheet **30** (core sheet **30a**) that is adjacent to the stacked portion **41** of the magnetic plate **40** in the axial direction includes through holes **30d** extending in the plate thickness direction that are formed at locations corresponding to the protrusions **42a**. The protrusions **42a** of the magnetic plate **40** are pressed and fitted (dowel-swaged) into each through hole **30d** of the core sheet **30a**. Thus, the annular portion **42** of the magnetic plate **40** is fixed to the annular portion **32** of the core sheet **30a**, and the magnetic plates **40** are formed integrally with the two axial sides of the main core **31**.

In the present embodiment, the through holes **30d** to which the protrusions **42a** of the magnetic plates **40** are swaged is formed only in the core sheets **30** that are adjacent to the magnetic plates **40**. Instead, the through hole **30d** may be formed in a number of (e.g., two to three) the core sheets **30** from the core sheet **30** that is adjacent to each magnetic plate **40**. Alternatively, the through holes **30d** may be formed in all of the core sheets **30**.

The protrusions **32a** and **42a** formed when a pressing process is performed each have an outer diameter (dowel diameter) set to be suitable for the thickness of the steel plate that is processed so that an appropriate protrusion amount may be ensured for the protrusions **32a** and **42a**. More specifically, in the present embodiment, the plate thickness **T1** of the magnetic plate **40** is greater than the plate thickness **T2** of the core sheet **30**. Thus, the dowel diameter of each protrusion **42a** between the magnetic plate **40** and the core sheet **30a** is set to be greater than the dowel diameter of the protrusion **32a** between the core sheets **30**. This provides an appropriate protrusion amount for the protrusions **32a** and **42a**. As a result, the desirable swaging strength is obtained. Further, a larger dowel diameter increases the influence of the protrusions **32a** and **42a** on a magnetic flow (i.e., large magnetic resistance). Thus, it is desirable that the minimum dowel diameter be set to obtain the swaging strength.

When stacking the core sheets **30**, which are punched out from steel plates with the same punching die (not shown), to form the main core **31** of the present embodiment, the core sheets **30** are rotated and shifted from one another in the circumferential direction by a predetermined angle (90 degrees). This offsets and limits deterioration in the cogging torque characteristics caused by the accuracy of each core sheet **30** in the stator core **21** (particularly, the accuracy of the circumferential width for each tooth formation portion **33**). That is, if the core sheets **30** are stacked without being shifted from one another, the cogging torque characteristics may be deteriorated by, in particular, variations in the shape of the tooth formation portions **33** of the core sheets **30**. In this respect, by shifting the cogging torque characteristics of the core sheets **30** in the circumferential direction, most of the amplitude of the cogging torque may be canceled so that satisfactory cogging torque characteristics may be obtained as a whole.

The outer circumferential core projections **26** of the stator core **21** are formed at locations set in accordance with the number of teeth **24** (angle between the teeth **24**) so that each core sheet **30** may be rotated and stacked. That is, in the present embodiment, since there are sixty teeth **24**, the outer circumferential core projections **26** are formed at intervals of ninety degrees, which is the multiple of the six-degree circumferential interval of the teeth **24**.

In the present embodiment, the projections **34** of the core sheets **30** (projections **45** of the magnetic plates **40**) are formed at ninety-degree intervals in the circumferential direction. Thus, by setting the projections **34** (projections **45**) at the corners of the four sides of a square steel plate when punching steel plates to form the core sheets **30** (magnetic plates **40**), smaller steel plates may be used. This improves the yield.

As shown in FIGS. **5** and **7**, each slot **S** of the stator core **21** receives a sheet of an insulating member **47**, which is formed from an insulative resin material. Each insulating member **47** is formed along the wall surface of the slot **S** and bent at the radially outer end of the slot **S**. Each insulating member **47** is axially inserted into the slot **S** and has an axial length that is set to be slightly greater than the axial length of the slot **S**. Thus, the two axial ends of the insulating member **47** project out of the two axial ends of the slot **S**.

Armature Windings

As shown in FIGS. **7** and **9**, the armature windings **22** attached to the stator core **21** described above includes a plurality of segment conductors **25**. The armature windings **22** for three phases (U-phase, V-phase, and W-phase) are in a Y connection that connect predetermined ones of the segment conductors **25**. The segment conductors **25** are formed from wires having the same cross-sectional shape (trapezoidal cross-section).

Each segment conductor **25** includes two straight portions **51** (see FIG. **5**) that are inserted into the slots **S**, a first projection **52** that projects out of a slot **S** in one axial direction (closer to rear frame **11**) and a second projection **53** that projects out of a slot **S** in the other axial direction (closer to the front frame **12**). The segment conductor **25** is bent at a portion of the first projection **52** and substantially U-shaped. The first and second projections **52** and **53** radially face the rotor opposing portion **44** at the two axial sides through a gap.

The two straight portions **51** are formed so that their radial positions are shifted from each other and are each inserted into the slot **S** at different circumferential positions. The straight portions **51** are arranged at the inner side of the insulating member **47** in each slot **S** (refer to FIG. **7**). The insulating member **47** electrically insulates the segment conductors **25** from the stator core **21**.

The segment conductors **25** are arranged so that four straight portions **51** are aligned in the radial direction in each slot **S**. FIG. **9** shows two types of segment conductors **25x** and **25y** used as the segment conductors **25**. In the outer segment conductor **25x** shown in FIG. **9**, the two straight portions **51** are arranged as the first one and the fourth one from the radially inner side. In the segment conductor **25y** shown in FIG. **9**, the two straight portions **51** are arranged as the second one and the third one from the radially inner side. The armature windings **22** are mainly formed from the two types of the segment conductors **25x** and **25y**. However, for example, a different type of segment conductor (e.g., segment conductor including only one straight portion) may be used as the segment conductor forming an end of an armature winding **22** (power supply connecting terminal, neutral point connecting terminal, etc.).

Each straight portion **51** of the segment conductor **25** extends through a slot **S** in the axial direction. The second projection **53** of the segment conductor **25** projecting close to the front frame **12** is bent in the circumferential direction and electrically connected to the second projection **53** of another segment conductor **25** or a special type of segment conductor through welding. Thus, the segment conductors **25** form the armature windings **22**.

The first and second projections **52** and **53** of the segment conductor **25** are bent in the circumferential direction from the straight portion **51** at the two axial ends of the slot **S**. FIG. **8** is an enlarged view showing the periphery of the axial end of the slot **S**. The first projection **52** shown in FIG. **8** is bent in the circumferential direction. As shown in FIG. **8**, a chamfered portion **43a**, which is chamfered to have an arcuate shape, is formed at the corner of each tooth formation portion **43** in the magnetic plate **40** (stacked portion **41**) forming one axial end of the slot **S**. In the same manner, in the magnetic plate **40** closer to the second projection **53**, a chamfered portion **43a** is formed at the corner of each tooth formation portion **43** forming the other axial end of the slot **S**. The chamfered portion **43a** has an arcuate cross-section and curved in the circumferential direction along the bent shape of the first and second projections **52** and **53** to widen the area of contact with the bent portion. This limits local application of force from the corners of the tooth formation portions **43** to the bent portions in the circumferential direction of the first and second projections **52** and **53**. This reduces damages to the bent portions. In the same manner, damages are reduced in the insulating member **47** held between the bent portions of the first and second projections **52** and **53** and the chamfered portions **43a**. In the present embodiment, the plate thickness **T1** of the magnetic plate **40** (plate thickness of the tooth formation portion **43**) is greater than the plate thickness **T2** of the core sheet **30**. This allows the curvature radius **Rm** of the chamfered portion **43a** to be set to be greater than the plate thickness **T2** of the core sheet **30**. Thus, damages to the bent portion of the segment conductor **25** may be reduced in a further preferable manner by the chamfered portion **43a** that have a large curvature radius **Rm**. The chamfered portion **43a** may have a straight cross-section.

As shown in FIG. **9**, the first projection **52** including the bent portion **25a** of the segment conductor **25** is formed to tilt (bulge) toward the radially outer side. The bent portion **25a** is thus located toward the radially outer side of the radially middle section of the slot **S**, and the radially inner side end of the first projection **52** is located at the radially outer side of the radially inner side end of the slot **S**. This widens the gap in the radial direction of the first projection **52** and the rotor opposing portion **44** of the magnetic plate **40**. Thus, interference is limited between the first projection **52** and the rotor opposing portion **44** in a further preferable manner. This not only obtains the insulation of the segment conductor **25** and the rotor opposing portion **44** in a further preferable manner but also limits increases in the cogging torque and the decreases in the output that would occur when the rotor opposing portion **44** is deformed by interference with the first projection **52**.

The second projection **53** of the segment conductor **25** does not include a bent portion, and second projections **53** are welded and joined with each other. This easily obtains the gap between the second projections **53** and the rotor opposing portions **44**. The welding portions of the second projections **53** are formed at the axially outer side from the axial distal end (side opposite to the main core) of the rotor opposing portions **44** closer to the front frame **12**. Thus, the rotor opposing portion **44** is less likely to become hindered by welding of the second projection **53**. This improves the workability and further ensures insulation of the second projections **53** and the rotor opposing portions **44**. The welding portions of the second projections **53** may be set at the axially inner side of the axial distal end (closer to the main core **31**) of the rotor opposing portion **44** closer to the front frame **12**. In this case, the second projections **53** do not

project to the axially outer side from the rotor opposing portions **44**. This contributes to miniaturization of the stator **13** in the axial direction.

Holding Structure of Stator Core

As shown in FIG. **1**, the stator holding portions **11b** and **12b** of the frames **11** and **12** holding the stator **13** having the above structure are cylindrical and extend in the axial direction from the main body portions **11a** and **12a** of the frames **11** and **12**.

As shown in FIGS. **2** and **9**, the stator holding portions **11b** and **12b** each include a fitted portion **71** fitted to an axial end of the stator core **21**. FIG. **9** shows the motor cross-section taken in the radial direction at a location where an outer circumferential core projection **26** of the stator core **21** is not formed. The fitted portion **71** is cylindrical and has an inner diameter that substantially conforms to the outer diameter of the cylindrical portion **23** of the stator core **21**. Four accommodation recesses **72** are formed in the fitted portion **71** to receive the outer circumferential core projections **26** of the stator core **21**. The inner circumferential surface of the fitted portion **71** contacts, in the radial direction, the outer circumferential surface of the cylindrical portion **23** (portion where the outer circumferential core projections **26** are not formed). This aligns the frames **11** and **12** and the stator core **21**, and the stator core **21** is held in the radial direction by the fitted portion **71**.

As shown in FIG. **1**, the outer circumferential core projections **26** of the stator core **21** are fitted into the accommodation recesses **72** formed in the fitted portions **71**, respectively. A bottom surface **72a** of each accommodation recess **72** in the axial direction contacts the axial end of the corresponding outer circumferential core projection **26** in the axial direction (specifically, projection **45** of the magnetic plate **40**). That is, the accommodation recesses **72** of the stator holding portions **11b** and **12b** are formed to hold the outer circumferential core projections **26** in between from two axial sides. Under this condition, the through bolts **15** couple and fasten the frames **11** and **12** to each other. This holds the outer circumferential core projections **26** of the stator core **21** between the accommodation recesses **72** of the stator holding portions **11b** and **12b**. Each accommodation recess **72** is in circumferential engagement with the corresponding outer circumferential core projection **26**. This positions the frames **11** and **12** and the stator core **21** in the circumferential direction. The outer circumferential surface of the cylindrical portion **23** of the stator core **21** is exposed to the exterior through the gap between the stator holding portions **11b** and **12b** in the axial direction.

The four accommodation recesses **72** are arranged at positions corresponding to the outer circumferential core projections **26**, that is, at an interval of 90 degrees in the circumferential direction. Two of the accommodation recesses **72** located at opposing positions and separated by 180 degrees from each other are formed at positions axially overlapping the fastening portions **11c** and **12c** of the frames **11** and **12**. The fastening portions **11c** and **12c** receive the holding load in the axial direction from the through bolts **15**, and the accommodation recesses **72** are formed at positions axially extending from the fastening portions **11c** and **12c**. Accordingly, the bottom surfaces **72a** of the accommodation recesses **72** contacts the outer circumferential core projections **26** along lines on which the holding load of the through bolts **15** act. That is, the reaction force applied to the bottom surfaces **72a** of the accommodation recesses **72** from the outer circumferential core projections **26** and the holding load received by the fastening portions **11c** and **12c** from the through bolts **15** do not form a force couple. This further

limits deformation, particularly, in the stator holding portions **11b** and **12b** and the fastening portions **11c** and **12c** of the frames **11**. As shown in FIG. **9**, the stator holding portions **11b** and **12b** of the frames **11** and **12** contacts the entire circumference of the section closer to the radially outer side of the annular portions **42** (cylindrical portion **23**). In other words, the stator holding portions **11b** and **12b** are formed to hold in between not only the outer circumferential core projections **26** but also the entire circumference of the section closer to the radially outer side of the annular portions **42** from both axial sides. Thus, the holding load received by the frames **11** and **12** from the through bolts **15** may be dispersed in the circumferential direction. This further suppresses deformation of the frames **11** and **12**.

The distance from the axis of the stator core **21** to the center of each protrusion **32a** (recess **32b**) is set to be smaller than the distance from the axis of the stator core **21** to each outer circumferential core projection **26**. That is, the protrusions **32a** (recess **32b**) are formed at the radially inner side of the outer circumferential core projections **26**, which are held between the frames **11** and **12**. When the protrusions **32a** and the recesses **32b** are swaged and fixed to the radially inner side of the annular portions **42** held between the frames **11** and **12**, that is, locations separated from the region held between the frames **11** and **12**, this limits increases in the magnetic resistance that occur when the protrusions **32a** and the recesses **32b** receive the holding load.

Rotor

As shown in FIG. **1**, the rotor **14** includes the rotation shaft **18** axially supported by the bearings **16** and **17**, a cylindrical rotor core **61** fixed to and rotated integrally with the rotation shaft **18**, and a plurality of (ten in the present embodiment) field magnets **62** fixed to the outer circumferential surface of the rotor core **61**. The field magnets **62** are formed by ferrite magnets, and the magnetic poles (N pole and S pole) are arranged to alternately differ in the circumferential direction. The axial length of the rotor core **61** and the field magnet **62** of the rotor **14** is set to be substantially equal to the axial length of the inner circumferential end of the stator core **21** (i.e., length from the distal end of the rotor opposing portion **44** of one magnetic plate **40** to the distal end of the rotor opposing portion **44** of the other magnetic plate **40**). In other words, the field magnets **62** radially faces the inner circumferential surface of the main core **31** of the stator core **21** and the rotor opposing portions **44** of each magnetic plate **40**.

The distal end of the rotation shaft **18** (left end in FIG. **1**) extends through the front frame **12** and projects out of the motor **10**. A joint **63** that rotates integrally with the rotation shaft **18** is arranged at the distal end of the rotation shaft **18**. The joint **63** is coupled to an external device (not shown), and transmits the rotation of the rotation shaft **18** to the external device.

The operation of the present embodiment will now be described.

The magnetic field generated when current is supplied to the armature windings **22** of the stator **13** cooperates with the magnetic field of the field magnet **62** of the rotor **14** through the inner circumferential surface of the main core **31** and the rotor opposing portions **44** of each magnetic plate **40** to rotate the rotor **14**. In the present embodiment, the plate thickness **T1** of each magnetic plate **40** is set to be greater than the plate thickness **T2** of each core sheet **30**. Thus, magnetic saturation does not easily occur in the magnetic plates **40**, and magnetism force may easily be drawn through the magnetic plates **40**.

11

The rotor opposing portions **44** of each magnetic plate **40** are each formed to axially extend from the end closer to the rotor **14** (radially inner end) of each tooth **24** of the stator core **21**. This obtains the axial length of the surface of the stator core **21** facing the rotor **14** (inner circumferential surface of the stator core **21**) and achieves high output. The first and second projections **52** and **53** of the segment conductor **25** projecting from both axial sides of the slots **S** are arranged in voids located at the radially outer side of the rotor opposing portions **44**. The first and second projections **52** and **53** face the rotor opposing portions **44** in the radial direction at the two axial sides. Accordingly, the axial length of the stator **13** (in the present embodiment, length from the axial end of the first projection **52** to the second projection **53**) may be reduced while ensuring the output with the rotor opposing portions **44** of the magnetic plate **40**.

Since the stacking thickness of the main core **31** of the stator core **21** is reduced while ensuring the output with the rotor opposing portions **44**, the variations (tolerance) in the stacking thickness of the main core **31** may be reduced. This reduces variations in the axial distance between the frames **11** and **12** that hold the main core **31** in between. Further, variations are reduced in the axial distance of the entire motor **10**. The magnetic plate **40** has a larger variation (tolerance) as the plate thickness **T1** increases. Variations in the axial size of the entire motor **10** can be further reduced by, for example, forming the frames **11** and **12** to hold only the main core **31** and not contact the magnetic plates **40** in the axial direction, as shown in FIG. **11** that will be described later.

In the present embodiment, the outer circumferential surface of the cylindrical portion **23** of the stator core **21** is exposed to the exterior from the gap between the frames **11** and **12** (stator holding portions **11b** and **12b**) in the axial direction. This obtains superior properties for releasing heat from the stator core **21** toward the radially outer side. The segment conductors **25** of the armature windings **22** in the present embodiment include the straight portions **51** aligned and arranged along the radial direction in each slot **S**. Thus, the occupying rate of the armature windings **22** may be increased while allowing for heat to be easily released in the radial direction. Thus, by using the segment conductors **25** in the structure of the present embodiment having superior properties for releasing heat from the stator core **21** toward the radially outer side, the stator **13** has preferable heat releasing properties. Further, in the present embodiment, the outer circumferential core projections **26** are formed on the outer circumferential surface of the cylindrical portion **23** exposed to the exterior from the gap between the stator holding portions **11b** and **12b** in the axial direction. This increases the heat releasing area (exposed area of the outer circumference) of the stator core **21** and further improves the heat releasing property.

In the structure that uses the segment conductors **25** in the armature windings **22**, a large number of slots **S** (number of teeth **24**) accommodate the segment conductors **25**, and the circumferential width of the tooth **24** tends to decrease. Therefore, in each tooth **24**, to widen the area of the surface (radially inner side end face) opposing the rotor **14** and enhance the output, the structure that axially extends the radially inner side end face of the tooth **24** with the rotor opposing portion **44** as in the present embodiment is suitable. The tooth **24** of the present embodiment has a structure in which magnetic force easily concentrates at the boundary of the radial extending portion **24a**, in which the circumferential width decreases toward the radially inner side, and the wide portion **24b**. In this respect, the stacked portion **41**

12

of the magnetic plate **40** is overlapped with the boundary. This reduces the magnetic concentration.

The present embodiment has the following advantages.

(1) The motor **10** includes the rear frame **11** and the front frame **12** that hold, in between, the stator **13** in the axial direction. The stator core **21** includes the outer circumferential core projections **26** (held portion) that project toward the radially outer side from the cylindrical portion **23** (main circumferential portion) forming the circumferential region. Further, the rear frame **11** and the front frame **12** are formed to hold, in between, the outer circumferential core projections **26** of the stator core **21** in the axial direction. This structure allows the outer circumferential core projections **26** that receive the holding load of the through bolts **15** (coupling member) in the stator core **21** to be located closer to the through bolts **15** in the radial direction. This limits the formation of a force couple at the frames **11** and **12** and, consequently, limits the deformation of the frames **11** and **12**.

The cylindrical portion **23** of the stator core **21** is exposed to the exterior from between the frames **11** and **12**. Thus, heat is released from the stator **13** in a satisfactory manner. The outer circumferential core projections **26** that project toward the radially outer side are formed in the exposed section of the cylindrical portion **23**. This increases the heat releasing area (exposed area of the outer circumference) of the stator core **21** and improves the heat releasing properties.

(2) The armature windings **22** are formed by a plurality of segment conductors **25**. The segment conductors **25** include first and second projections **52** and **53** that are inserted into the slots **S**, which extend in the stator core **21** in the axial direction, and project out of the slots **S** in the axial direction. The stator **13** in which the armature windings **22** are formed by the segment conductor **25** has a high occupying rate of the armature windings **22** but easily generates heat. Thus, the use of the segment conductors **25** in the structure having superior heat releasing properties due to the outer circumferential core projections **26** of the stator core **21** forms a further preferable structure.

(3) The frames **11** and **12** include the fastening portions **11c** and **12c** (coupling portion), which receive the holding load in the axial direction from the through bolts **15**, and contact portions (bottom surfaces **72a** of the accommodation recesses **72**), which are formed at locations axially extending from the fastening portions **11c** and **12c** and contact the outer circumferential core projections **26** of the stator core **21** in the axial direction. The outer circumferential core projection **26** is sandwiched in the axial direction by the bottom surfaces **72a** of the accommodation recesses **72** in each of the frames **11** and **12**. In this structure, the bottom surfaces **72a** of the accommodation recesses **72** contacts the outer circumferential core projections **26** along lines on which the holding load of the through bolts **15** act. Thus, force couple based on the holding load of the frames **11** and **12** is not generated and, consequently, deformation of the frames **11** and **12** is further limited.

(4) The outer circumferential core projections **26** each include the engagement groove **26a** (engagement recess) that engages the through bolt **15** in the circumferential direction. Thus, the outer circumferential core projections **26** of the stator core **21** are engaged, in the circumferential direction, with the through bolts **15**, which couple the frames **11** and **12**. This restricts free rotation of the stator core **21**.

(5) The frames **11** and **12** include the fitted portions **71** fitted to the axial ends of the stator core **21**. Thus, the fitted portions **71** stably hold the stator core **21** (in particular, in the radial direction).

13

(6) The core sheets **30** of the stator core **21** are formed by performing punching with the same punching die. When stacking the core sheets **30** in the axial direction, the same punching locations are shifted from one another in the circumferential direction. That is, the stator core **21** has a structure in which the core sheets **30** are rotated and stacked to limit biases in the dimensional accuracy of each core sheet **30**. This reduces the cogging torque related to the number of slots of the stator **13** and the number of poles of the rotor **14**.

(7) The stator core **21** includes sixty teeth, and four outer circumferential core projections **26** are arranged at a 90-degree interval in the circumferential direction. This allows the core sheets **30** to be rotated and stacked in a preferable manner. When punching out and forming the core sheets **30** and the magnetic plates **40** from square steel plates, the projections **45** are set at the corners of the four sides of the steel plate when performing punching. This allows the core sheets **30** and the magnetic plate **40** to be formed from smaller steel plates and improves yield.

(8) The stator core **21** includes the main core **31** and the magnetic plates **40**, which are located at the axial ends of the main core **31**. The magnetic plates **40** each include the stacked portion **41**, which is stacked on the core sheet **30** (core sheet **30a**) at the axial end of the main core **31**, and the rotor opposing portions **44**, which extend toward the axially outer side from the end of the stacked portion **41** closer to the rotor **14** and radially face the rotor **14**. In this structure, the rotor opposing portions **44** of the magnetic plate **40** extend toward the axially outer side (side opposite to the main core). This allows the axial length of the main core **31** to be limited and further contributes to the miniaturization of the motor **10** in the axial direction without reducing the area opposed to the rotor **14** in the stator core **21**.

The first and second projections **52** and **53** of the segment conductors **25** are formed to radially face the rotor opposing portions **44** of the magnetic plate **40**. This limits enlargement of the stator **13** in the axial direction while obtaining the area opposed to the rotor **14** in the stator core **21** with the rotor opposing portions **44** of the magnetic plate **40** and achieving high output.

(9) The stacked portion **41** of the magnetic plate **40** is caulked and fixed to the core sheet **30** at the axial end of the main core **31**, so that the magnetic plate **40** is easily fixed with respect to the core sheet **30**.

(10) The swaged portions (protrusions **42a** and through holes **30d**) of the magnetic plates **40** and the core sheets **30** are formed at the radially inner side of the outer circumferential core projections **26** and at the same circumferential positions as the outer circumferential core projections **26** in the cylindrical portion **23**. In this structure, the protrusions **42a** and the through holes **30d** are formed in the cylindrical portion **23** at locations where the radial width is increased due to the formation of the outer circumferential core projection **26**. This limits the influence of the protrusions **42a** and the through holes **30d** on the magnetic flow in the cylindrical portion **23**.

(11) The swaged portions (protrusions **42a** and through holes **30d**) of the magnetic plates **40** and the core sheets **30**, and the swaged portions (protrusions **32a** and recesses **32b** (through holes **30c**)) of the core sheets **30** both implement dowel swaging and are set to have different dowel diameters. In this structure, the dowel diameter is set in accordance with the thickness of the core sheets **30** and the thickness of the magnetic plates **40**, the locations where the swaged portions are formed, and the like. When the plate thickness **T1** of the magnetic plate **40** is greater than the plate thickness **T2** of the core sheet **30** like in the present

14

embodiment, the dowel diameter of the swaged portions (protrusions **42a** and through holes **30d**) of the magnetic plates **40** and the core sheets **30** is increased. This limits increase in the magnetic resistance at the swaged portions while obtaining swaging strength.

(12) When the swaged portions (protrusions **32a** and recesses **32b** (through holes **30c**)) of the core sheets **30** are formed at the radially inner side of the locations held between the frames **11** and **12** in the cylindrical portion **23**, the swaged portions between the core sheets **30** are formed at positions separated from the locations held between the frames **11** and **12**. This limits increases in the magnetic resistance that occurs when the swaged portions receive the holding load.

(13) The plate thickness **T1** of the magnetic plate **40** is set to be greater than the plate thickness **T2** of the core sheet **30** so that magnetic force is easily drawn through the magnetic plates **40**. This further increases the output. Since the plate thickness **T1** of the magnetic plate **40** is greater than the plate thickness **T2** of the core sheet **30**, the large chamfered portions **43a** (e.g., chamfered portion having an arcuate cross-section and a curvature radius **Rm** that is greater than the plate thickness **T2** of the core sheet **30**) is easily formed at each corner of the tooth formation portion **43** of the magnetic plate **40**. This limits damages to the bent portions of the segment conductors **25**.

The embodiment described above may be modified as follows.

In the embodiment described above, the frames **11** and **12** hold, in between, the outer circumferential core projections **26** in the stator core **21** and sections of the cylindrical portion **23** located closer to the radially outer side (circumferential region of the cylindrical portion **23**). Instead, for example, the frames **11** and **12** may hold, in between, only the outer circumferential core projections **26**. This structure has the following advantages.

(14) Since the frames **11** and **12** hold, in between, only the outer circumferential core projections **26** in the stator core **21**, the formation of the force couple in the frames **11** and **12** is limited in a further preferable manner.

(15) The stator core **21** includes the core sheets **30** stacked in the axial direction. Each core sheet **30** is relatively thin and is thus easily deformed and magnetically altered by the holding load from the frames **11** and **12**. In this regards, the influence of the holding load on the magnetic flow of the stator core **21** is more effectively limited since the outer circumferential core projections **26**, in which the magnetic flow is small compared to the cylindrical portions **23**, are held between the frames **11** and **12**.

In the embodiment described above, the core sheets **30** and the magnetic plates **40** respectively include the projections **34** and **45** forming the outer circumferential core projections **26**. The bottom surfaces **72a** of the accommodation recesses **72** contact (hold in between) the projections **45** of the magnetic plates **40** in the axial direction. Instead, the structure shown in FIGS. **10** and **11**, for example, may be employed.

In the structure shown in FIGS. **10** and **11**, the projections **45** are omitted from the magnetic plates **40** of the embodiment described above so that the annular portion **42** has a circular rim, and the outer circumferential core projections **26** are formed by only the projections **34** of the core sheets **30**. The bottom surfaces **72a** of the accommodation recesses **72** contact (hold in between) the projections **34** of the core sheet **30** in the axial direction (see FIG. **11**).

This structure further decreases the holding load applied between the magnetic plates **40** and the core sheets **30a** to

15

the swaged portions (protrusions **42a** and through holes **30d**) or the welded portions. Further, since the frames **11** and **12** are formed so as not to contact the magnetic plates **40** in the axial direction, variations (tolerance) may be limited in the axial distance between the frames **11** and **12** holding the main core **31**. This limits variations in the axial dimensions of the entire motor **10**. When increasing the output by increasing the plate thickness **T1** of the magnetic plates **40** to be greater than the plate thickness **T2** of the core sheets **30** like in the embodiment described above, variations increases in the plate thickness of the magnetic plate **40**. Accordingly, since the frames **11** and **12** are formed not to contact the magnetic plates **40** in the axial direction, the effect for limiting variations in the axial dimensions of the entire motor **10** becomes further outstanding.

In the embodiment described above, the segment conductors **25** are each bent at the first projection **52** connecting the two straight portions **51** inserted through each slot **S**. Further, the segment conductors **25** are joined by welding the second projections **53**. Instead, for example, as shown in FIG. **12**, the two straight portions **51** may be formed as discrete bodies that are welded together in the first projection **52** to form the segment conductor **25**. Instead of welding, the segment conductors **25** may be connected by structure using a discrete member such as a bus bar or the like.

In the embodiment described above, twelve protrusions **32a** (recesses **32b**) are formed at equal intervals (30-degree intervals) in the circumferential direction of the annular portion **32**. However, the number and locations of the protrusions **32a** (recesses **32b**) may be changed.

In the embodiment described above, two protrusions **42a** are provided for each projection **45** (eight protrusions **42a** in total). Instead, one protrusion **42a** may be provided for each projection **45** (four protrusions **42a** in total).

The setting of the dowel diameter and the like of the swaged portion (protrusions **32a** and **42a**, recesses **32b** and **42b**, and through hole **30c** and **30d**) in the embodiment described above may be changed in accordance with the structure.

In the embodiment described above, the fitted portion **71** is arranged in each of the frames **11** and **12**. Instead, the fitted portion **71** may be omitted from each of the frames **11** and **12** in the embodiment described above. Further, the stator holding portions **11b** and **12b** of the frames **11** and **12** may include fitted portions positioned and fitted (externally fitted) onto the outer circumferential core projections **26**.

In the embodiment described above, the frames **11** and **12** are made from a metal material such as aluminum, steel, and the like. Instead, each of the frames **11** and **12** may be made from a resin material as long as it has the same strength as the metal material.

In the embodiment described above, the two through bolts **15** couple the frames **11** and **12**. However, three or more through bolts **15** may couple the frames **11** and **12**.

In the embodiment described above, the outer circumferential core projections **26** include the engagement grooves **26a** that engages the through bolt **15** in the circumferential direction. Instead, the engagement grooves **26a** may be omitted from the outer circumferential core projections **26** so that the outer circumferential core projections **26** do not engage the through bolts **15**.

The number of teeth **24** of the stator core **21** does not have to be sixty and may be changed.

In the embodiment described above, four outer circumferential core projections **26** are arranged at an interval of 90 degrees in the circumferential direction. Instead, for

16

example, two outer circumferential core projections **26** may be arranged at an interval of 180 degrees. Alternatively, three outer circumferential core projections **26** may be arranged at an interval of 120 degrees. In these cases, the core sheets **30** punched out from steel plates by the same punching die are shifted, when stacked, by 180 degrees (or 120 degrees) in the circumferential direction to form the main core **31**. When three outer circumferential core projections **26** are arranged at 120-degree intervals, each core sheet **30** is rotated by 120 degrees when stacked to cancel three waves of the cogging torque wave including the cogging torque component unique to the core sheets **30**. As a result, the cogging torque may be reduced.

In the embodiment described above, the rotor opposing portion **44** is trapezoidal when viewed from the radial direction. Instead, the rotor opposing portion **44** only needs to be shaped so that magnetic force may be drawn and may be, for example, tetragonal as viewed in the radial direction.

In the embodiment described above, the stacked portion **41** of the magnetic plate **40** includes the annular portion **42** and the tooth formation portions **43**. Instead, the stacked portion **41** may be formed by only the tooth formation portions **43**.

In the embodiment described above, is swaged and fixed to the main core **31** (core sheets **30**). Instead, the magnetic plate **40** may be, for example, adhered or welded to the main core **31** (core sheets **30**).

In the embodiment described above, the plate thickness **T1** of the magnetic plate **40** is set to be greater than the plate thickness **T2** of the core sheet **30**. Instead, the plate thickness **T1** of the magnetic plate **40** may be set to be less than or equal to the plate thickness **T2** of the core sheet **30**.

In the embodiment described above, the magnetic plate **40** is arranged on two axial sides of the main core **31**. Instead, the magnetic plate **40** may be arranged only on one axial side of the main core **31**. Further, in the embodiment described above, the stator core **21** is formed by the main core **31** including the core sheets **30** and the two magnetic plates **40**. Instead, the stator core **21** may be formed by only the main core **31** (core sheets **30**).

In the embodiment described above, the main core **31** of the stator core **21** has a stacking structure of the core sheets **30**. Instead, the main core **31** may be, for example, an integral molded product that is casted.

In the embodiment described above, the armature windings **22** are formed by the segment conductors **25**. Instead, for example, armature windings may be obtained by winding copper wires around the teeth.

In the embodiment described above, the ferrite magnet is used as the field magnet **62** of the rotor **14**. Instead, for example, neodymium magnet or the like may be used.

In the embodiment described above, the rotor core **61** and the field magnets **62** of the rotor **14** may have axial lengths that differ from the axial length of the inner circumferential end of the stator core **21** (i.e., length from the distal end of the rotor opposing portion **44** of one magnetic plate **40** to the distal end of the rotor opposing portion **44** of the other magnetic plate **40**).

The invention claimed is:

1. A motor comprising:

a stator including a stator core, a plurality of teeth extending toward a radially inner side from a main circumferential portion of the stator core, and an armature winding attached to the teeth, wherein the stator core includes a held portion that projects toward a radially outer side from the main circumferential portion;

a first frame and a second frame respectively arranged on two axial sides of the stator core to hold, in between, at least the held portion of the stator core in the axial direction, wherein the first frame and the second frame are formed so that the main circumferential portion of the stator core is exposed to the exterior from between the first frame and the second frame;

a coupling member that couples the first and second frames at the radially outer side of the stator while applying a holding load to the first and second frames in the axial direction; and

a rotor rotatably supported by the first and second frames and arranged at the radially inner side of the stator, wherein

the stator core includes a main core and a magnetic plate arranged at an axial end of the main core; and

the magnetic plate includes a stacked portion, which is stacked on the axial end of the main core, and a rotor opposing portion, which extends toward the axially outer side from an end of the stacked portion closer to the rotor and which radially faces the rotor, and

the armature winding projects in the axial direction from the axial distal end of the rotor opposing portion,

the armature winding includes a plurality of segment conductors, wherein the plurality of segment conductors are welded and joined with each other, and the welding portion of the segment conductors is formed at an axially outer side from the axial distal end of the rotor opposing portion,

the main core includes a plurality of core sheets stacked in the axial direction, and adjacent ones of the core sheets in the axial direction are swaged and fixed to each other, the plurality of core sheets including a first core sheet adjacent the magnetic plate and including additional core sheets,

the stacked portion of the magnetic plate is stacked on the first core sheet at the axial end of the main core, and swaged and fixed to the first core sheet at the axial end of the main core, and

the magnetic plate and the first core sheet are swaged to form a first swaged portion, the additional core sheets are swaged to form a second swaged portion, the first swaged portion is formed at a location different from the second swaged portion in a circumferential direction, and not overlapped with the second swaged portion in the axial direction.

2. The motor according to claim 1, wherein each segment conductor is inserted into a slot formed between adjacent ones of the teeth in the circumferential direction and includes a projection that projects out of the slot in the axial direction, and the projections of the segment conductors are electrically connected to each other.

3. The motor according to claim 2, wherein the projection includes a first projection that projects out of the slot in one axial direction and a second projection that projects out of the slot in the other axial direction,

the first projection includes a bent portion of the segment conductor and is formed to tilt toward the radially outer side, and

the second projection includes the welding portion.

4. The motor according to claim 1, wherein each of the first and second frames includes a coupling portion, which receives the holding load applied in the axial direction from the coupling member, and a contact portion, which extends from the coupling portion in the axial direction and contacts the held portion of the stator core in the axial direction; and

the held portion is axially held between the contact portions of the first and second frames.

5. The motor according to claim 1, wherein the first and second frames hold, in between, the held portion and a section of the main circumferential portion located at the radially outer side.

6. The motor according to claim 1, wherein the first and second frames hold, in between, only the held portion of the stator core.

7. The motor according to claim 1, wherein the held portion includes an engagement recess that engages the coupling member in a circumferential direction.

8. The motor according to claim 1, wherein each of the first and second frames includes a fitted portion fitted to an axial end of the stator core.

9. The motor according to claim 1, wherein the additional core sheets are punched and formed by the same punching die, and the additional core sheets are stacked in the axial direction so that the same punching locations are shifted from each other in the circumferential direction.

10. The motor according to claim 9, wherein the teeth are sixty in number, and the held portion is one of a plurality of held portions arranged at 90-degree or 180-degree intervals in the circumferential direction.

11. The motor according to claim 9, wherein the teeth are sixty in number, and the held portion is one of three arranged at 120-degree intervals in the circumferential direction.

12. The motor according to claim 1, wherein the first swaged portion is formed at the radially inner side of the held portion at the same circumferential position as the held portion in the main circumferential portion.

13. The motor according to claim 1, wherein the magnetic plate and the core sheet are dowel-swaged to form the first swaged portion, the core sheets are dowel-swaged to form the second swaged portion, the first and the second swaged portions are set to have different dowel diameters, and each of the first and the second swaged portions include protrusions fitting into recesses, each one of the protrusions contacting bottom and side surfaces of one of the recesses.

14. The motor according to claim 13, wherein a plate thickness of the magnetic plate is greater than that of the core sheet, and the dowel diameter of the first swaged portion is greater than that of the second swaged portion.

15. The motor according to claim 1, wherein the second swaged portion is formed on the main circumferential portion at the radially inner side of a location held between the first and second frames.