

B. SCULLY & A. E. RIGBY.  
 BANK RETAINER FOR CULVERTS  
 APPLICATION FILED JULY 8, 1912.

1,069,650.

Patented Aug. 5, 1913.

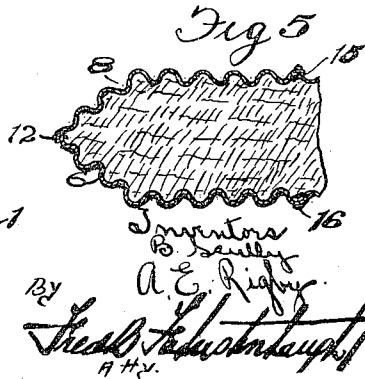
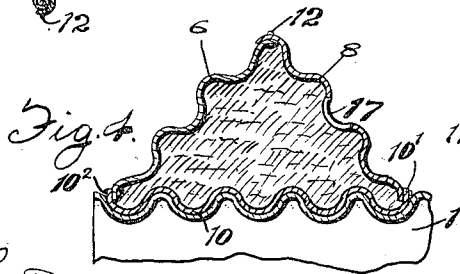
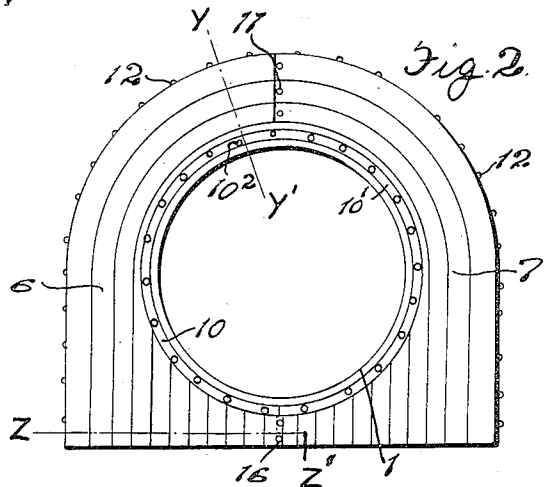
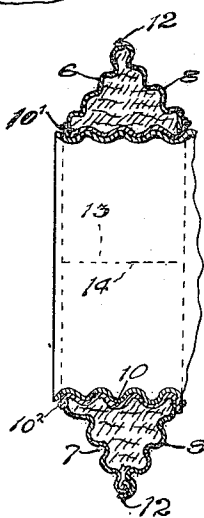
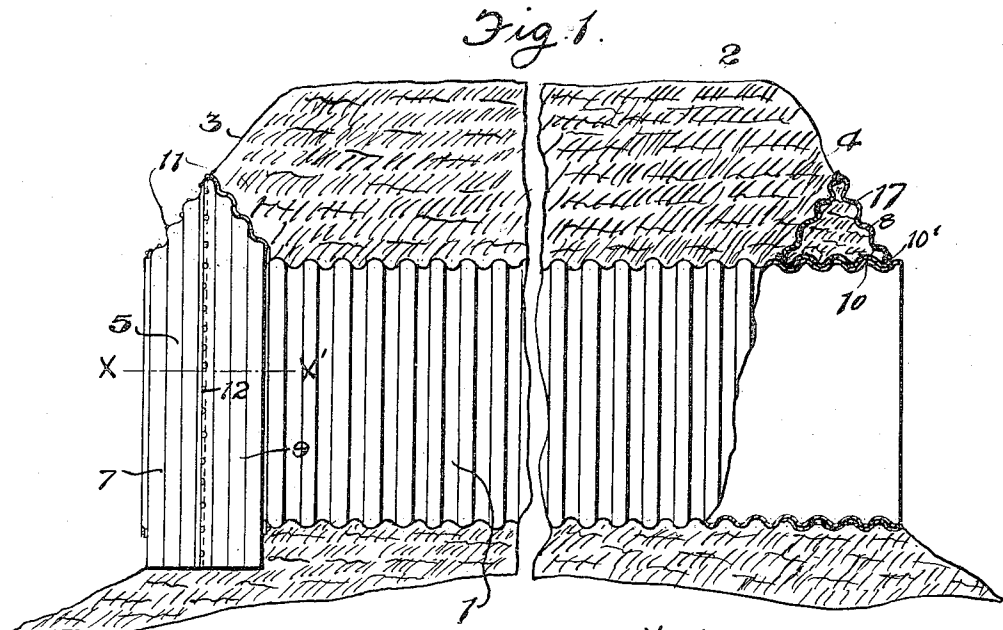

Witnesses  
 Roland Foster  
 J. M. Saylor.

Inventors  
 B. Scully  
 A. E. Rigby  
 BY  
 Sheel & Schmitt  
 ATTYS.

# UNITED STATES PATENT OFFICE.

BARTHOLOMEW SCULLY AND ALFRED ERNEST RIGBY, OF WINNIPEG, MANITOBA,  
CANADA.

BANK-RETAINER FOR CULVERTS.

1,069,650.

Specification of Letters Patent.

Patented Aug. 5, 1913.

Application filed July 8, 1912. Serial No. 708,209.

To all whom it may concern:

Be it known that we, BARTHOLOMEW SCULLY and ALFRED ERNEST RIGBY, both of the city of Winnipeg, in the Province of Manitoba, Canada, have invented certain new and useful Improvements in Bank-Retainers for Culverts, of which the following is the specification.

The device relates to a bank retainer for culverts and the object of the invention is to provide a strong, durable and efficient device of this class which can be manipulated and placed on a culvert at comparatively low cost the particular feature of the device being that it is attached to the culvert and not built around it as is customary.

With the above objects in view the invention consists essentially in the arrangement and construction of parts hereinafter more particularly described and later pointed out in the appended claims.

Figure 1 represents a side elevation of the device as it appears when in use the roadway being shown in section. Fig. 2 represents an end view. Fig. 3 represents a horizontal sectional view through the retainer the section being taken in the plane denoted by the line X—X' Fig. 1. Fig. 4 is an enlarged detailed vertical sectional view through the retainer the section being taken in the plane denoted by the line Y—Y' Fig. 2. Fig. 5 is a horizontal sectional view through a portion of the retainer the section being taken in the plane denoted by the line Z—Z' Fig. 2.

In the drawing like characters of reference indicate corresponding parts in each figure.

1 represents a culvert passing through a roadway 2 in the ordinary manner. In the present instance the culvert is shown as formed from corrugated sheet metal the ends of the culvert extending beyond the banks 3 and 4 of the roadway.

Where no bank protectors are supplied it is found that gravel or earth accumulates at the mouth of the culvert and in time clogs up to a certain extent the end of the culvert. To overcome this difficulty the present practice has been to build a retaining wall from boards, stones, cement or other such material to hold or bank up the earth and prevent it from lodging at the end of the culvert. We have found that this is rather expensive and unsatisfactory and ac-

ordingly have devised a protector more or less in the shape of a collar which can be shipped to the point where it is to be used and immediately applied on the ends of the culvert to form a retaining wall with very little difficulty. The collar indicated in the drawings by reference numeral 5 in the present instance comprises a body portion formed from a number of corrugated sheet metal plates there being two similar front plates 6 and 7, two similar rear plates 8 and 9. A central split portion or thimble 10 connects these plates together, as will be hereinafter described. The plates 6 and 7 and those 8 and 9 are riveted together at the top at 11 to form front and back sections, which sections are afterward fastened together by rivets 12. The plates 6, 7, 8 and 9 are cut away or shaped to receive the culvert which in reality passes through the retainer.

10 is a thimble or central portion in the form of a split pipe having the corrugations thereof constructed so as to fit the corrugations of the culvert on which the thimble is applied. The ends of the thimble are flared outwardly at 10' and securely riveted at 10<sup>2</sup> to the inner edges of the plates. The butted ends 13 and 14 of the thimble are located on the lower side of the culvert to allow the bases of the sections to be split apart sufficiently at 15 to permit the retainer to be placed over the end of the culvert. It is to be noticed that the retainer is more or less triangular in cross section so that a stout structure is presented.

When the device is to be used the bank of the roadway is dug out around the pipe and the base of the retainer is spread apart sufficiently to permit the thimble to be passed over the pipe. The base is then drawn together and fastened by bolts 16 which pass through the adjoining edges of the plates 6 and 7 and those 8 and 9. The corrugations of the thimble then fit snugly the corrugations of the culvert and hold the retainer from lateral displacement on the culvert. An opening 17 is formed in the back or bank-side of the retainer and the interior of the retainer is filled up with sand or gravel as the case may be. Any deposit from the banks of the roadway, which are afterward filled in is effectively prevented by the attached retainer from accumulating around the mouth or outlet of the culvert.

What we claim as our invention is:—

1. The combination with a culvert, of a bank retainer formed from sheet metal releasably secured to the culvert, said retainer comprising a central thimble and a body portion carried by the thimble, as and for the purpose specified.
2. A bank retainer for culverts comprising a central thimble designed to fit around the end of the culvert, and a suitably reinforced body portion secured to the thimble, as and for the purpose specified.
3. A bank retainer for culverts comprising a central split metallic thimble designed to receive the end of the culvert and a reinforced metallic body portion secured to the thimble, as and for the purpose specified.
4. The combination with a corrugated sheet metal culvert, of a corrugated split metal thimble adapted to be applied on and receiving the corrugations of the culvert, and a corrugated sheet metal body portion in the form of a collar carried by the thimble, said body portion being substantially triangular in cross section, as and for the purpose specified.
5. The combination with a corrugated sheet metal culvert, of a corrugated sheet metal thimble adapted to be applied on and receiving the corrugations of the culvert and a corrugated sheet metal body portion in the form of a collar carried by the thimble, said body portion being substantially triangular in cross section, and having an opening formed in the side thereof to admit of filling in the interior of the collar, as and for the purpose specified.
6. The combination with a culvert, of a bank retainer formed from sheet metal fitted on the culvert, said retainer comprising a body portion, a central member carried by the body portion receiving and enveloping the culvert, as and for the purpose specified.
7. The combination with a corrugated culvert, of a bank retainer fitted on the culvert and having the central portion thereof adjacent the culvert receiving the culvert between corrugations and extending laterally over an adjacent corrugation at the point of greatest diameter of said corrugation.
8. The combination with a corrugated culvert, of a bank retainer fitted on the culvert, said retainer comprising a body portion through which the culvert passes and a central portion carried by the body portion enveloping and fitting the corrugations of the culvert as and for the purpose specified.
9. The combination with a corrugated culvert, of a bank retainer fitted on the culvert,

said retainer comprising a body portion through which the culvert passes and a central corrugated member permanently secured to the body portion, said corrugated member having the corrugations thereof fitting the corrugations of the culvert, as and for the purpose specified.

10. A bank retainer for corrugated culverts comprising a suitably reinforced body portion having a central opening therein and a corrugated member secured to the body portion and bordering the opening aforesaid, as and for the purpose specified.

11. A bank retainer for corrugated culverts comprising a suitably reinforced body portion having an opening therein for the reception of the culvert and a corrugated central portion secured to the side of the body portion and bordering the opening therein, as and for the purpose specified.

12. A bank retainer for corrugated culverts comprising a suitably reinforced body portion designed to be applied on the culvert and provided with an opening to receive the culvert when applied and a central corrugated member permanently secured to the body portion and adjoining the opening aforesaid, the corrugations of the central member being designed to receive and fit around the corrugations of the culvert when said body portion is applied thereon, as and for the purpose specified.

13. A hollow bank retainer for culverts having an opening to admit of filling in the interior thereof, as and for the purpose specified.

14. The combination with a culvert, of a hollow bank retainer adapted to fit over the end of the culvert, said retainer having an opening in the side thereof remote from the end of the culvert on which the said retainer is fitted to admit of filling in the interior thereof, as and for the purpose specified.

15. The combination with a culvert of a hollow bank retainer adapted to fit over the end of the culvert and having the side thereof remote from the end of the culvert on which the said retainer is applied inclined and provided with an opening to admit of filling in the interior, as and for the purpose specified.

Signed at Winnipeg this 31 day of May 1912.

BARTHOLOMEW SCULLY.  
ALFRED ERNEST RIGBY.

In the presence of—  
G. S. ROXBURGH,  
R. FOSTER.