

No. 733,170.

PATENTED JULY 7, 1903.

P. DIEHL.  
OVERSEAMING SEWING MACHINE.

APPLICATION FILED JULY 24, 1902.

NO MODEL.

2 SHEETS—SHEET 1.

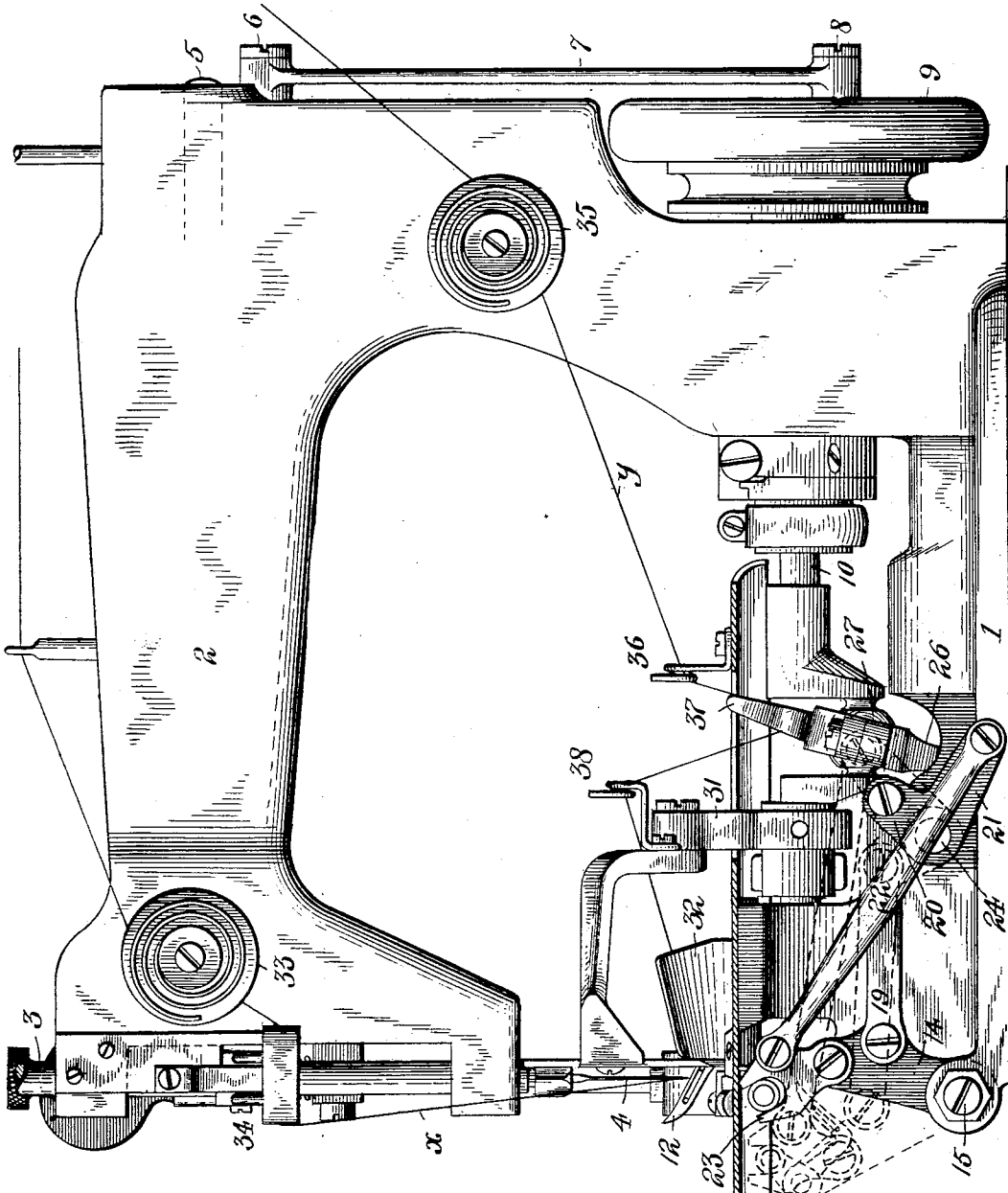

Fig. 1.

Witnesses:-

J. B. McGirr.  
Henry A. Hornemann.

Inventor:-

Philip Diehl  
by Harry J. Miller  
Atty.

P. DIEHL.  
OVERSEAMING SEWING MACHINE.

APPLICATION FILED JULY 24, 1902.

NO MODEL.

2 SHEETS—SHEET 2.

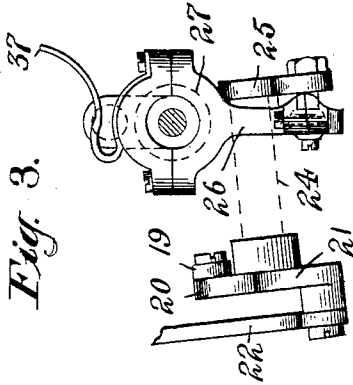

Fig. 3.

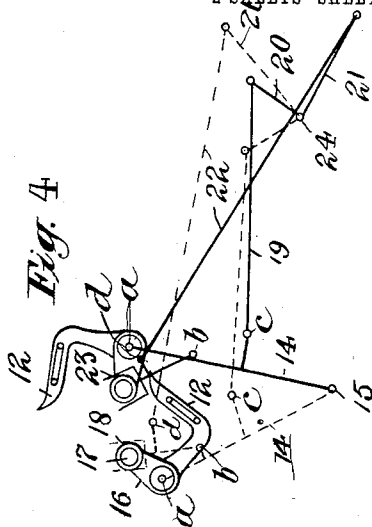

Fig. 4

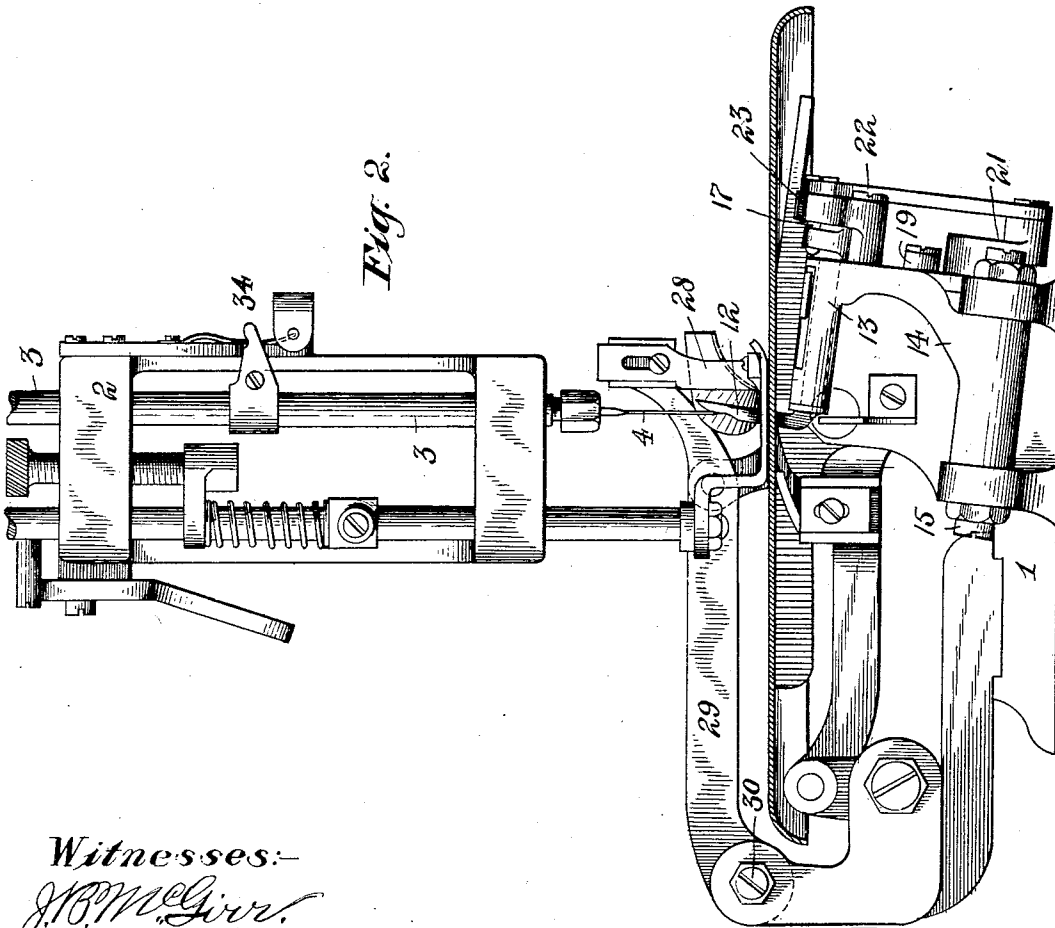

Fig. 2.

Witnesses:-  
*J. B. McGinnis*  
*Henry A. Hornemann*

Inventor:-  
*Philip Diehl*  
*by Harry Miller, Atty*

# UNITED STATES PATENT OFFICE.

PHILIP DIEHL, OF ELIZABETH, NEW JERSEY, ASSIGNOR TO THE SINGER MANUFACTURING COMPANY, A CORPORATION OF NEW JERSEY.

## OVERSEAMING SEWING-MACHINE.

SPECIFICATION forming part of Letters Patent No. 733,170, dated July 7, 1903.

Application filed July 24, 1902. Serial No. 116,773. (No model.)

*To all whom it may concern:*

Be it known that I, PHILIP DIEHL, a citizen of the United States, and a resident of Elizabeth, in the county of Union and State of New Jersey, have invented certain new and useful Improvements in Overseaming Sewing-Machines, of which the following is a specification.

This invention relates to an improvement in that class of so-called "overlock-stitch" sewing-machines effecting the enchainment of a needle and looper-thread and designed more particularly for covering the raw edges of knit goods and for uniting the edges of the latter when overlapped and fed to the stitching devices for the purpose, but subsequently opened out to form a flat seam with the interlooped attaching-threads joining the fabric across the edges upon both the upper and under faces. This class of stitching has been performed heretofore by means of a vertically-reciprocating eye-pointed needle and a "somersault" or "inverting" single-implementation thread-carrying looper having both a rocking and a bodily-reciprocating motion and adapted to seize and enter a loop of needle-thread beneath the fabric and then pass its loop upward and around the edge of the fabric, where it is entered by a succeeding loop of needle-thread above the fabric, after which the looper backs out of the previously-seized needle-thread loop in the return to its initial position beneath the fabric to seize the needle-thread loop previously passed through its own loop above the fabric. The looper mechanisms for performing such operations as previously constructed and arranged have proved ineffective for the high speeds at present required of this class of overedge sewing-machines; and it is therefore the primary object of the present invention to provide actuating mechanism for affording both positive and easy movements to such class of loopers having motions both of translation and oscillation in order to render them not only certain in their coöperation with the needle, but simple in construction and capable of operation at high speeds both quietly and with a minimum wear of parts.

The invention consists, essentially, in a looper mechanism comprising a looper car-

ried by and receiving bodily-reciprocating movements upon a rocking or other reciprocating frame, and means also carried by or movable with and in substantially the direction of movement of said rocking frame connected with the driving-shaft of the machine for oscillating said looper upon its shaft at one end of its bodily-reciprocating movements.

The invention will be understood by reference to the annexed drawings, in which—

Figure 1 is a side view of a machine embodying my invention with the face-plate omitted and the forward portion of the cloth-plate removed to better expose the parts beneath the same, and Fig. 2 is a front elevation of the same. Fig. 3 is an elevation of a portion of the looper-actuating mechanism, showing its connection with the main shaft; and Fig. 4, a diagrammatic view showing the looper in its two extreme positions above and beneath the cloth-plate and indicating the relation of the several members of the actuating mechanism corresponding with such looper positions.

The base 1 of the machine is shown provided with the overhanging arm 2, in the forward portion of which is fitted the vertically-reciprocating needle-bar 3, carrying the needle 4 and actuated by the usual crank-and-pitman connection with the forward end of the rock-shaft 5, having upon its rear end the crank-pin 6, connected by the pitman 7 with a crank-pin 8, carried by the balance-wheel 9, mounted upon the rotary main shaft 10, all as in a well-known type of "Singer" machine.

Coöperating with the needle 4 and mounted to oscillate in a plane oblique to the latter is the eyed thread-carrying looper 12, fixed upon one end of a slightly-inclined rock-shaft 13, disposed substantially parallel with the line of feed and mounted in suitable bearings in a swinging frame or carrier 14, pivoted upon centers 15, so as to reciprocate thereon transversely of the line of the feed, the looper-shaft having upon its opposite end a crank 16, carrying a pin 17, having preferably an antifricition-roller 18. The reciprocating looper-supporting frame or carrier 14 is connected intermediate its pivotal bearings and

the looper rock-shaft mounted thereon by means of a link 19 with the shorter arm 20 of a substantially right-angular bell-crank lever whose other and longer arm 21 is connected by a link 22 with a forked lever 23, pivoted upon the frame or carrier 14 and embracing the crank-pin 17 18 upon the looper rock-shaft. The bell-crank 20 21 is fixed upon the outer end of a short intermediate shaft 24, mounted in suitable transverse bearings in the base of the machine and having upon its inner end a lateral crank-arm 25, deriving a vibrating motion from a pitman 26, connected therewith at one end by a ball-joint and at the opposite end embracing a ball-crank 27 upon the main shaft 10. As indicated in the drawings, the several rock-shafts and pivotal pins of the train of mechanism intermediate the looper-shaft and the pitman 26 are disposed in lines parallel with the looper-shaft.

By reference to Fig. 1 it will be observed that the bell-crank or rocker 20 21 is so disposed upon its supporting rock-shaft 24 that in the lower extreme position of the looper 12 (indicated by dotted lines) both the arms 20 and 21 are substantially above the axis of the rock-shaft and in the motions to and from such position actuate the parts connected with the links 19 and 22 at nearly equal speeds; but as said bell-crank approaches the full-line position indicated in said figure the shorter arm 20 maintains its substantially uniform speed of movement, while the longer arm nearly crosses the center of oscillation, thus producing a differential speed of motion of the reciprocating members 19 and 22, and therefore of the carrier 14 and forked lever 23, the arrested crank-pin 17 18, in conjunction with the more quickly-moving carrier 14 of its shaft 13, serving to turn the looper into inverted position, as indicated in said figure. The mechanism for communicating to the looper and its carrier their respective motions thus comprises the common actuating device, consisting of the bell-crank or rocker 20 21 and the intermediate bodily-reciprocating link members 19 and 22, attached to the latter by direct pivotal connections.

While the present embodiment of the invention exemplifies a practical form of the improvement, it is obvious that the principles involved therein are susceptible of wide variations, the essential feature of the device being the reciprocating carriage upon which the looper is mounted, combined with means permanently connected with the looper and movable therewith for turning the looper once for each reciprocation of its supporting-carrier.

It is obviously immaterial to the present invention in its broader sense by what means the looper is pivotally mounted upon its reciprocating carrier and whether the crank-pin by means of which it is oscillated be located upon a looper rock-shaft or directly

upon the shank of the looper. Nor is it material whether the looper-supporting frame or carrier be given a reciprocating motion in a circular path, as indicated in the annexed drawings, or in a straight line, the position of the looper in any case being controlled positively at all times and its inversion being effected without the shock resulting from the collision of a moving with a stationary part or from a rocking movement communicated thereto for every motion of translation in either direction.

As the connection between the driving-shaft and the reciprocating frame or carrier 14 insures the latter's positive motion, it is obviously unnecessary that the independent connection of the looper supported and reciprocated bodily by such member should be attached to the same source of motion as represented herein nor, in fact, to any moving member, so long as the vibrating member 23, serving to vary the motion of the looper in respect of that of the reciprocating carrying-frame, is arranged to insure the differential motion of the crank or other device carried by or rigidly connected with the looper in order to cause said looper to perform a single rocking movement upon its axis of oscillation corresponding with each motion of translation communicated to it by its reciprocating carrier.

It is further evident that the present improvement is equally adapted for use with machines employing one or two threads in the production of overseams.

The machine is shown provided with the usual feeding devices and with a trimmer, of which the upper member consists of the knife 28, carried by a vibrating bar 29, fixed to a rock-shaft mounted upon the center screws 30 and actuated by a pivotal connection with an eccentric-rod 31, embracing an eccentric upon the main shaft 10, and the lower member of said trimmer consists of a stationary knife secured beneath the cloth-plate in a well-known manner. The cuttings are deflected away from the operative parts of the machine by means of a guard 32, rising above the cloth-plate adjacent to the cutting-knives and slightly in advance of the path of the looper.

In threading the machine for operation the needle-thread  $x$  is led between the upper thread-tension disks 33 and thence through the take-up device 34 to the needle 4, while the looper-thread  $y$  is led between the lower thread-tension disks 35, through the guide-eye 36, under the take-up hook 37, carried by the head of the pitman 26, and through the guide-eye 38, mounted upon and vibrated with the cutter-bar 29, to the looper 12.

The operation of the machine is similar to that of others of the same general class. As the needle starts to rise from its lowest position its loop is seized and entered by the looper, which as it approaches the end of its forward movement turns over on its axis and

projects above the cloth-plate and at the beginning of its return movement offers its loop of thread to the now descending needle, which passes through the same, while the looper in its return to initial position backs out of the previously-seized needle-loop. The upper thread take-up is timed to set the needle-thread as the ascending needle reaches its highest position, while the lower thread take-up similarly acts upon the lower thread as the looper returns to its initial lower position.

Having thus set forth the nature of the invention, what I claim is—

1. In an overseaming sewing-machine, the combination with the main shaft and a needle deriving reciprocating movements therefrom, of a looper adapted to cooperate with said needle both above and below the work-plate in forming overseaming stitches, a reciprocating frame or carrier on which said looper is mounted to oscillate in a single plane of movement, and looper-actuating mechanism comprising two differentially-moving members deriving motion from said main shaft and pivotally connected, respectively, with said looper and its carrier.

2. In an overseaming sewing-machine, the combination with the main shaft and a needle deriving reciprocating movements therefrom, of a looper adapted to cooperate with said needle in forming stitches, a reciprocating frame or carrier on which said looper is mounted to oscillate, a rocking device or rocker connected with and actuated by means of said main shaft, and independent pivotal connections intermediate said rocking device or rocker and the looper and its carrier for communicating a bodily-reciprocating and rocking motion to said looper.

3. In a sewing-machine, the combination with a reciprocating needle, of a looper adapted to cooperate with said needle in forming stitches, a reciprocating frame or carrier on which said looper is mounted to oscillate, a bell-crank or rocker, and means for rocking the same, a connection between said reciprocating frame or carrier and said bell-crank or rocker at a point of the latter eccentric to its axis of motion, and a connection between said looper and said bell-crank or rocker also eccentric to its axis of motion and in angular relation to said first-named eccentric point of connection.

4. In a sewing-machine, the combination with a needle and means for giving the same vertical reciprocations, of a looper adapted to cooperate with said needle in forming stitches, a pivoted frame or carrier on which said looper is mounted to oscillate, a bell-crank or rocker and means for rocking the same, a connection between said pivoted frame or carrier and said bell-crank or rocker at a point of the latter eccentric to its axis of motion, and a connection between said looper and said bell-crank or rocker also eccentric to its axis of motion and in angular relation

to said first-named eccentric point of connection.

5. In a sewing-machine, the combination with a needle and means for reciprocating the same, of a looper adapted to cooperate with said needle in the formation of stitches, and provided with a crank-pin, a reciprocating frame or carrier on which said looper is mounted to oscillate, a bell-crank lever, one arm of which is connected with said frame or carrier and the other arm of which is connected with the crank-pin of said looper, and means for rocking said bell-crank lever.

6. In a sewing-machine, the combination with a needle and means for reciprocating the same, of a looper adapted to cooperate with said needle in the formation of stitches, and provided with a crank-pin, a reciprocating frame or carrier on which said looper is mounted to oscillate, a lever pivotally mounted upon and movable with said frame or carrier and connected with the crank-pin of said looper, a bell-crank lever, one arm of which is connected with said frame or carrier and the other arm of which is connected with said lever, and means for rocking said bell-crank lever.

7. In a sewing-machine, the combination with a needle and means for reciprocating the same, of a frame or carrier pivotally mounted upon the frame of the machine and adapted to swing transversely of the path of reciprocation of said needle, a looper rock-shaft mounted upon said frame or carrier and having upon one end a looper adapted to cooperate with said needle in the formation of stitches and carrying upon the opposite end a crank-pin, a lever pivotally mounted upon and movable with said swinging frame or carrier and connected with the crank-pin of said looper rock-shaft, a bell-crank lever, one arm of which is connected with said frame or carrier and the other arm of which is connected with said lever, and means for rocking said bell-crank lever.

8. In an overseaming sewing-machine, the combination with a needle and means for reciprocating the same, of a looper adapted to cooperate with said needle in forming over-edge stitches, a looper rock-shaft carrying said looper and provided with a crank, a carrier upon which said looper-shaft is mounted to rock, a main shaft disposed beneath the work-plate and provided with a bell-crank, a transverse rock-shaft having a crank-arm connected by a pitman with said crank upon the main shaft, and independent connections from said transverse rock-shaft to the looper-shaft and its carrier, respectively, for imparting to said looper a bodily-reciprocating and rocking motion.

9. In a sewing-machine, the combination with a needle and means for reciprocating the same, of a looper movable in a plane transversely of the line of feed and adapted to cooperate with said needle both above and below the work-plate in the formation of over-

edge stitches, a looper rock-shaft carrying said looper and provided with a crank, a carrier upon which said looper-shaft is mounted to rock, means for reciprocating said carrier 5 transversely of the direction of feed, a lever connected with the crank of said looper-shaft, and means, independent of said carrier-reciprocating means for vibrating said lever.

10. In a sewing-machine, the combination 10 with a needle and means for reciprocating the same, of a looper movable in a plane transversely of the line of feed and adapted to cooperate with said needle both above and below the work-plate in the formation of over- 15 edge stitches, a looper rock-shaft carrying said looper and provided with a crank, a carrier upon which said looper-shaft is mounted to rock, means for reciprocating said carrier transversely of the direction of feed, a forked 20 lever embracing the crank of said looper rock-shaft, and means for vibrating said lever differentially in respect of the reciprocations of said carrier.

11. In a sewing-machine, the combination 25 with a needle and means for reciprocating the same, of a looper movable in a plane transversely of the line of feed and adapted to cooperate with said needle both above and below the work-plate in the formation of over- 30 edge stitches, a looper rock-shaft carrying said looper and provided with a crank, a carrier upon which said looper-shaft is mounted to rock, means for reciprocating said carrier transversely of the direction of feed, a lever 35 having one end connected with the crank upon said looper-shaft and the other end pivoted upon said carrier, and means for imparting to said lever a to-and-fro movement differential in respect of that of said carrier.

40 12. In a sewing-machine the combination with a needle and means for reciprocating the same, of a looper movable in a plane transversely of the line of feed and adapted to cooperate with said needle both above and be-

low the work-plate in the formation of over- 45 edge stitches, a looper rock-shaft carrying said looper and provided with a crank, a carrier upon which said looper-shaft is mounted to rock, a vibrating lever connected with the crank of said rock-shaft, a bell-crank or 50 rocker and means for actuating it, and independent connections from said carrier and said vibrating lever to angularly-disposed pivotal points of said bell-crank or rocker.

13. In an overseaming sewing-machine, 55 the combination with the main shaft and a needle deriving reciprocating movements therefrom, of a looper adapted to cooperate with said needle both above and below the work-plate in forming overseaming stitches, 60 a reciprocating frame or carrier on which said looper is mounted to oscillate, and looper-actuating mechanism comprising two differentially and bodily reciprocating members deriving motion from said main shaft and 65 pivotally connected, respectively, with said looper and its carrier.

14. In an overseaming sewing-machine, the combination with a needle and means for reciprocating it, of a looper adapted to coop- 70 erate with said needle both above and below the work-plate in forming overseaming stitches, a reciprocating frame or carrier on which said looper is mounted to oscillate, and looper-actuating mechanism comprising two 75 differentially-moving members pivotally connected, respectively, with said looper and its carrier and deriving their movement from direct pivotal connections with a common actuating device. 80

Signed at Elizabeth, in the county of Union and State of New Jersey, this 23d day of July, A. D. 1902.

PHILIP DIEHL.

Witnesses:

HENRY J. MILLER,  
HENRY A. KORNE MANN.