

No. 747,487.

PATENTED DEC. 22, 1903.

C. H. ROLLINS.
VALVE MECHANISM FOR SHOWER BATHS.

APPLICATION FILED AUG. 20, 1902.

NO MODEL.

2 SHEETS—SHEET 1.

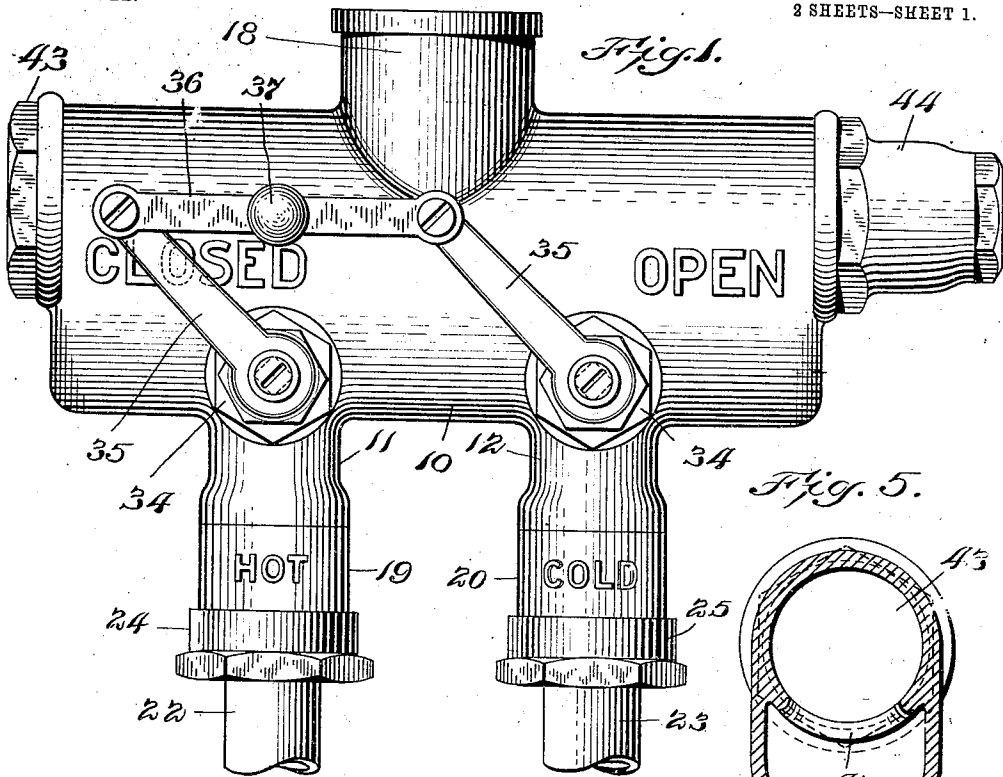
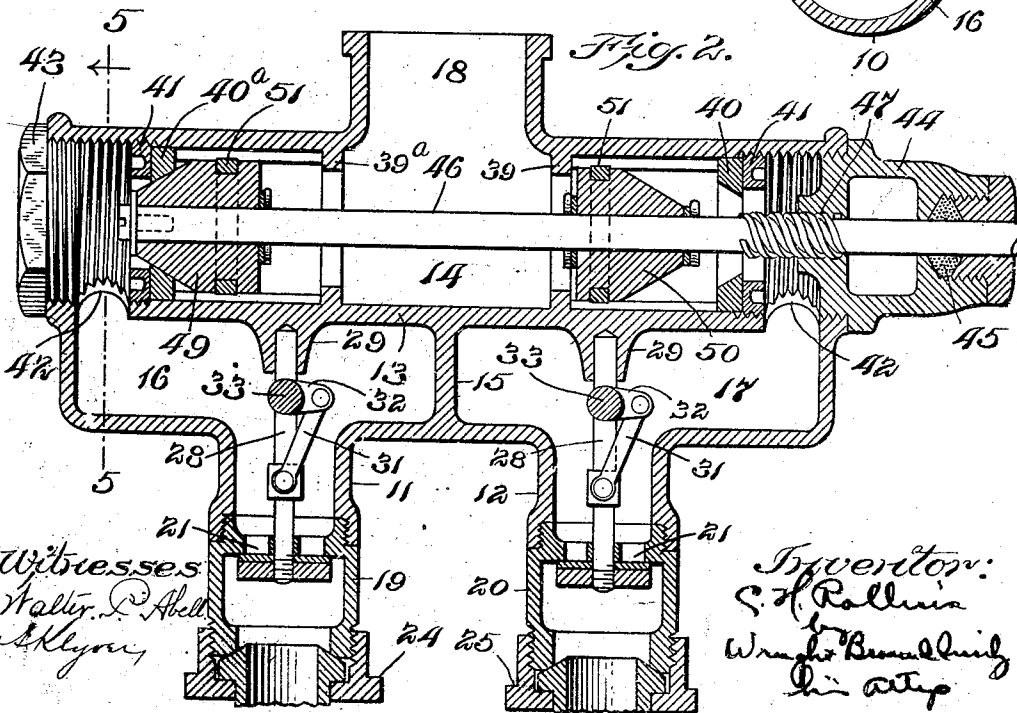
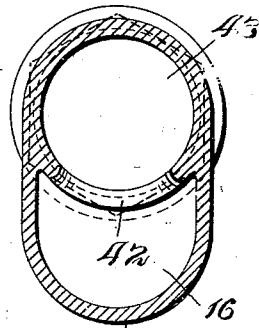

Fig. 5.



Witnesses
Halter & Abel
Attorneys

Inventor:
C. H. Rollins
by
Wm. B. Beardsley
Att'y

C. H. ROLLINS.
VALVE MECHANISM FOR SHOWER BATHS.

APPLICATION FILED AUG. 20, 1902.

NO MODEL.

2 SHEETS—SHEET 2.

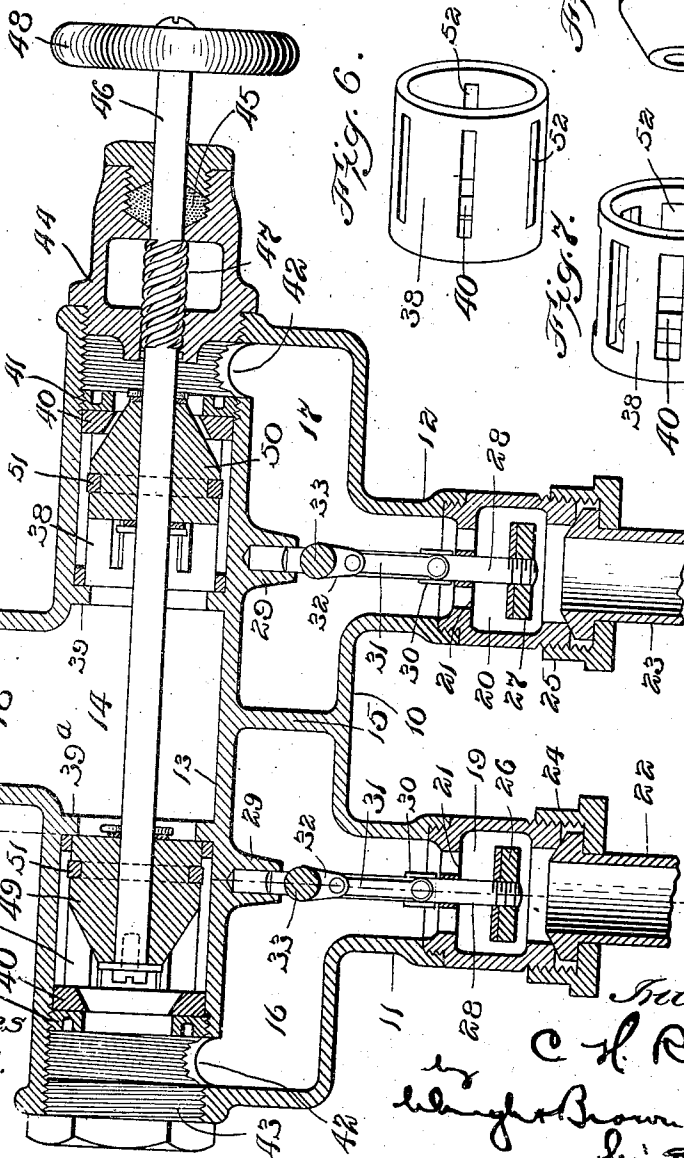
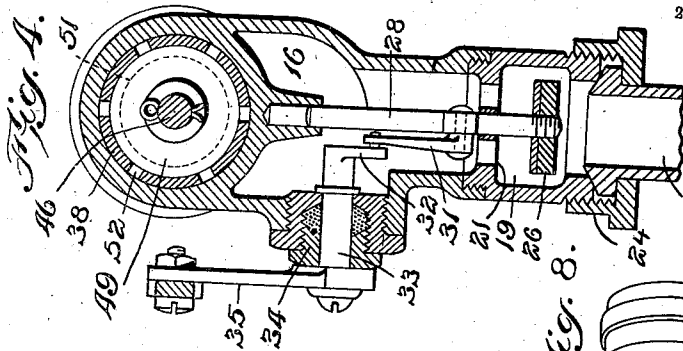

Fig. 6.

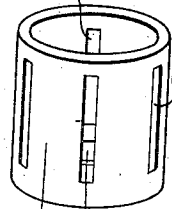

Fig. 8.

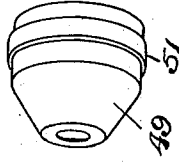
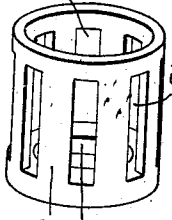

Fig. 3.

Witnesses
 Walter P. Hill.
 A. Klyman

Inventor:
 C. H. Rollins
 by *Wm. H. Brown & Son*
 his atty

UNITED STATES PATENT OFFICE.

CHARLES H. ROLLINS, OF WATERTOWN, MASSACHUSETTS, ASSIGNOR
OF ONE-HALF TO EDGAR W. ANTHONY, OF BROOKLINE, MASSACHUSETTS.

VALVE MECHANISM FOR SHOWER-BATHS.

SPECIFICATION forming part of Letters Patent No. 747,487, dated December 22, 1908.

Application filed August 20, 1902. Serial No. 120,380. (No model.)

To all whom it may concern:

Be it known that I, CHARLES H. ROLLINS, of Watertown, in the county of Middlesex and State of Massachusetts, have invented certain
5 new and useful Improvements in Valve Mechanism for Shower-Baths, of which the following is a specification.

This invention has relation to valve mechanism for shower-baths, and has for its object
10 to provide certain improvements therein by means of which the flow of hot and cold water can be accurately regulated.

In most buildings the cold water is delivered under the service or street pressure, while the
15 pressure of the hot water is considerably less, owing to its being delivered from the overhead tank to the boiler and being no more than the ordinary static pressure due to the height of the column of water leading to the
20 tank from the valve mechanism. As heretofore arranged, it has been difficult to secure a proper mixing of the hot and cold water to reach a desired temperature without danger
25 of the bather being scalded by a surplussage of hot water in his endeavor to regulate the flow of hot and cold water.

Another object of the invention, therefore, is to provide a valve mechanism in which the
30 liability of scalding will be further reduced by providing for the complete cutting off of the hot water when the valve is fully open.

In addition to these objects thus briefly mentioned the invention is designed to accomplish other purposes and to provide other
35 improvements, all of which will be fully explained in the following specification and pointed out in the appended claims.

Referring to the drawings, Figure 1 represents in front elevation my improved valve
40 mechanism. Fig. 2 represents a longitudinal section of the same, showing the valves all closed. Fig. 3 represents a similar section with the controlling-valve in position to cut off the hot water and deliver a small amount
45 of cold water. Fig. 4 represents a section on the line 4 4 of Fig. 3. Fig. 5 represents a section on the line 5 5 of Fig. 2. Fig. 6 represents in detail one of the barrels or bushings for the regulating-valve. Fig. 7 represents

another interchangeable bushing. Fig. 8 represents one of the valves.

On the drawings the mechanism is illustrated as being provided with a main casing 10, having depending therefrom two annular flanges 11 12. The interior of the casing is
55 provided with a web 13, which forms an open-ended cylinder 14. A partition 15 closes communication between the two ends of the main casing, except for the openings which
60 will be subsequently described. Outside of the web 13 and on both sides of the partition 15 are two chambers, (indicated, respectively, at 16 and 17,) with which communicate the inlets
65 formed by the annular flanges 11 and 12. Communicating with the interior of the cylinder 14, which forms a mixing-chamber, there is a large outlet 18 for the discharge of water. To the inlets 11 and 12 there are attached
70 valve-chambers 19 and 20, each being provided with a valve-seat 21. The delivery-pipes 22 and 23 for the hot and cold water, respectively, may be attached to the chambers 19 and 20 by flange-nuts 24 25. In the
75 said chambers 19 and 20 are two valves 26 27, which close with the pressure and normally rest against the seats 21. Said valves are
80 opened against the pressure of water by any suitable mechanism. As illustrated, said mechanism comprises for each valve a stem 28, whose upper end fits in a guide 29, formed
85 on the web 13. Each of the stems has attached thereto a block 30, which is loosely connected by a link 31 with a crank-arm 32 on a rock-shaft 33. Each rock-shaft passes
90 through a stuffing-box formed in two parts and indicated as a whole at 34. Each of the rock-shafts is provided with an arm 35, the free end of which is connected to a link 36, having a forwardly-projecting handle 37. By
95 swinging the handle to one side or the other the valves 26 27 may be opened or closed, as the case may be. The casing bears the words "Open" and "Closed" to indicate the position to which the handle 37 should be moved to open or close the valves 26 27. The movement of the last-mentioned valves is simultaneous, so that were the pressure of the hot and cold water equal the same amount of

each would be delivered to the chambers 16 and 17; but due to the high pressure of the cold water it will be seen that there would be an excess of cold water. Consequently I provide a regulating - valve, by which the amount of hot or cold water delivered to the mixing-chamber may be governed to suit any requirements.

In each end of the cylinder 13 there is placed a bushing or barrel 38, whose inner end bears against an internal flange or shoulder 39 or 39^a, which forms, as will be explained, a valve-seat. The other end of each barrel is formed with a second valve-seat, (indicated at 40 or 40^a.) The bushings are held in place by threaded washers 41. Each of the bushings communicates with the chamber immediately therebelow by a port 42, so that when water is delivered to said chambers it can flow through said ports into the ends of the cylinder 13 and, if unimpeded, to the mixing-chamber 14. One end of the main casing 10 is closed by a threaded head 43 and the other by a head 44, having a stuffing-box 45. An elongated valve-spindle 46 passes through the head 44 and the stuffing-box 45 and is provided with a thread 47 in operative engagement with a thread formed on the interior of the head 44, so that by rotating said spindle by means of the wheel or handle 48 it may be advanced in one direction or the other. Secured to the spindles are two valves, (indicated, respectively, at 49 and 50,) each of which is placed in one of the barrels 38. Each valve is substantially frusto-conical at one end and cylindrical at the other end and is adapted to engage either the seat 39 or 39^a or the seat 40 or 40^a, except that in the case of the valve 50 the frusto-conical portion never comes into actual intimate contact with its seats 40 or 39 so as to entirely cut off the flow of water, but will at all times permit a small amount of cold water to trickle past it. Each valve is provided with a circumferential groove, in which is placed a rubber gasket 51, fitting fairly tightly against the interior wall of the barrel. Consequently to provide for the flow of water past the said valve when it is not in engagement with either of its seats the barrel 38 is provided with a plurality of longitudinal grooves or slots 52, which form water-conduits. Preferably I provide for each complete valve mechanism a plurality of bushings or barrels having grooves varying in number and differing in width, so that I am able to provide for a differential flow of water through the barrels, all other things being equal. When the valve-spindle 46 is at the inward extreme of its movement, the valve 49 is seated against the seat 40^a and the valve 50 against the seat 39, and consequently no water can flow into the mixing-chamber from the chambers 16 and 17 even though the inlet-valves 26 and 27 be open, except a small amount of cold water. If the valve-spindle now be moved slightly to the right, water may flow past the valves 49 and 50 into the

mixing-chamber. The shape of the valves 49 and 50 is such that as the spindle moves outward a greater quantity of water can flow past the valve-seat 39 or 39^a than can pass the seat 40^a due to the conical end of the valve 49. A further movement of the valve-spindle will permit a free flow of hot water past the valve 49 and a checking of the flow of cold water; but as the valve-spindle continues its movement to the right the flat end of the valve 49 is brought into contact with the valve-seat 39^a, so as to entirely cut off the flow of hot water, while at the same time the conical point of the valve 50 does not come quite in contact with the seat 40 and a small amount of cold water is permitted to leak past it. Thus at no time can the hot water be admitted without the admission of more or less cold water, and consequently there is no liability for an excess of hot water. Preferably in each valve mechanism the barrels are furnished to meet the requirements of the hot and cold water service—that is to say, if the street pressure for the cold water is very high the number and size of the slots in the barrel for the valve 50 are reduced and the slots for the passage of the hot water are increased in size and width. Again, if it be found that under ordinary circumstances the hot water is delivered at a very high temperature the barrel may be so arranged as to deliver a relatively small quantity in comparison with the amount of cold water delivered past the valve 50. For the sake of convenience I term the valves 26 and 27 the "inlet-valves" and the valves 49 and 50 the "mixing" or "regulating" valves, since they perform the functions suggested or indicated by those terms.

There are several advantages incident to the construction which I have thus described which it may not be amiss to enumerate: First, by the provision of the inlet-valves 26 and 27 independent of the mixing-valves, the flow of water into the valve-casing may be entirely cut off, so as to relieve all pressure from the stuffing-boxes and prevent danger of leakage past them, and, second, in order that the operator may be reminded to close the inlet-valves the valve 50 never comes tightly against either of the seats 39 40, and consequently the leakage is sufficient to indicate that the flow of cold water is not entirely cut off.

I consider the employment of the slotted barrels or bushings as a great convenience, as the entire mechanism can be quickly adapted for any particular requirement without the change of any other of its parts.

It should be noted in conclusion that a complete movement of the mixing or regulating valves in either direction will substantially cut off the flow of both hot and cold water. Consequently where the valve mechanism is used in administering baths for medicinal purposes the attendant can by a slight movement in either direction effect-

ively cut off the flow of water in case it becomes necessary on account of the patient's condition.

I may further state that the invention is not limited to the particular idea of its use as herein described, as it may be employed in a variety of ways and for other purposes without departing from the spirit and scope of the invention.

Having thus explained the nature of the invention and explained a way of constructing and using the same, although without having attempted to set forth all of the forms in which it may be made or all of the modes of its use, I declare that what I claim is—

1. A valve mechanism of the character described, comprising a casing having a mixing-chamber and two inlet-chambers, two inlet-valves for admitting hot and cold water to said inlet-chambers, and two connected mixing-valves governing the admission of water from said inlet-chambers to the mixing-chamber.

2. A valve mechanism of the character described, comprising a casing having a mixing-chamber and two inlet-chambers, two inlet-valves for admitting hot and cold water to said inlet-chambers, means for simultaneously operating said valves, and two simultaneously-operated valves governing the admission of water from said inlet-chambers to said mixing-chamber.

3. A valve mechanism comprising a casing having a mixing-chamber with an outlet leading directly therefrom, and two valve-chambers communicating at their inner ends with said chamber and each provided with valve-seats at each end thereof, and connected valves in said chambers adapted to cooperate with the seats therein, for governing the passage of water through said valve-chambers into said mixing-chamber.

4. A valve mechanism comprising a casing having a mixing-chamber, and two valve-chambers communicating therewith, a valve in each chamber having two operative ends one of which is tapering, two seats in each valve-chamber adapted to cooperate alternately with the valve therein, and means for simultaneously operating said valves.

5. A valve mechanism comprising a casing having a mixing-chamber with an outlet leading directly therefrom, and two valve-cham-

bers communicating therewith, and having separate inlets, a removable barrel or bushing in each chamber having longitudinal conduits, and connected valves in said barrels or bushings.

6. A valve mechanism comprising a casing having a mixing-chamber, and two valve-chambers communicating therewith, a longitudinally-movable spindle passing through said valve-chambers, two valves on said spindle and arranged in said valve-chambers, and a seat at each end of each of said valve-chambers with which one of the valves may cooperate.

7. A valve mechanism comprising a casing having a mixing-chamber, two inlet-valves, two regulating-valves interposed between the inlet-valves and the mixing-chamber, and provisions whereby one of said regulating-valves in a closed position permits the leakage of a small amount of water except when the corresponding inlet-valve is closed.

8. A valve mechanism comprising a mixing-chamber having an outlet leading directly therefrom, two valve-chambers communicating therewith and having separate inlets, two connected valves operating in said chambers and interchangeable removable slotted bushings or barrels in said chambers.

9. A valve mechanism comprising a valve-chamber having a port and a seat at each end, a valve adapted to close against either seat, and a bushing in said chamber, having longitudinal conduits whereby the water may flow from one port through said conduits past the valve and out of the other port, when said valve is away from said seats.

10. A valve mechanism comprising two chambers having a common outlet and separate inlets, each chamber having two separate valve-seats, and connected valves, one in each chamber adapted to cooperate with one of the seats therein at each end of its movement, one of said valves being arranged to engage its seats to entirely cut off the passage of water, and the other fitting its seats loosely to permit a drip past it.

In testimony whereof I have affixed my signature in presence of two witnesses.

CHARLES H. ROLINS.

Witnesses:

MARCUS B. MAY,
WALTER P. ABELL.