

(No Model.)

F. C. PITCHER & A. J. Q. KNOWLTON.
ROLLER BUSHING FOR SHEAVES.

No. 549,686.

Patented Nov. 12, 1895.

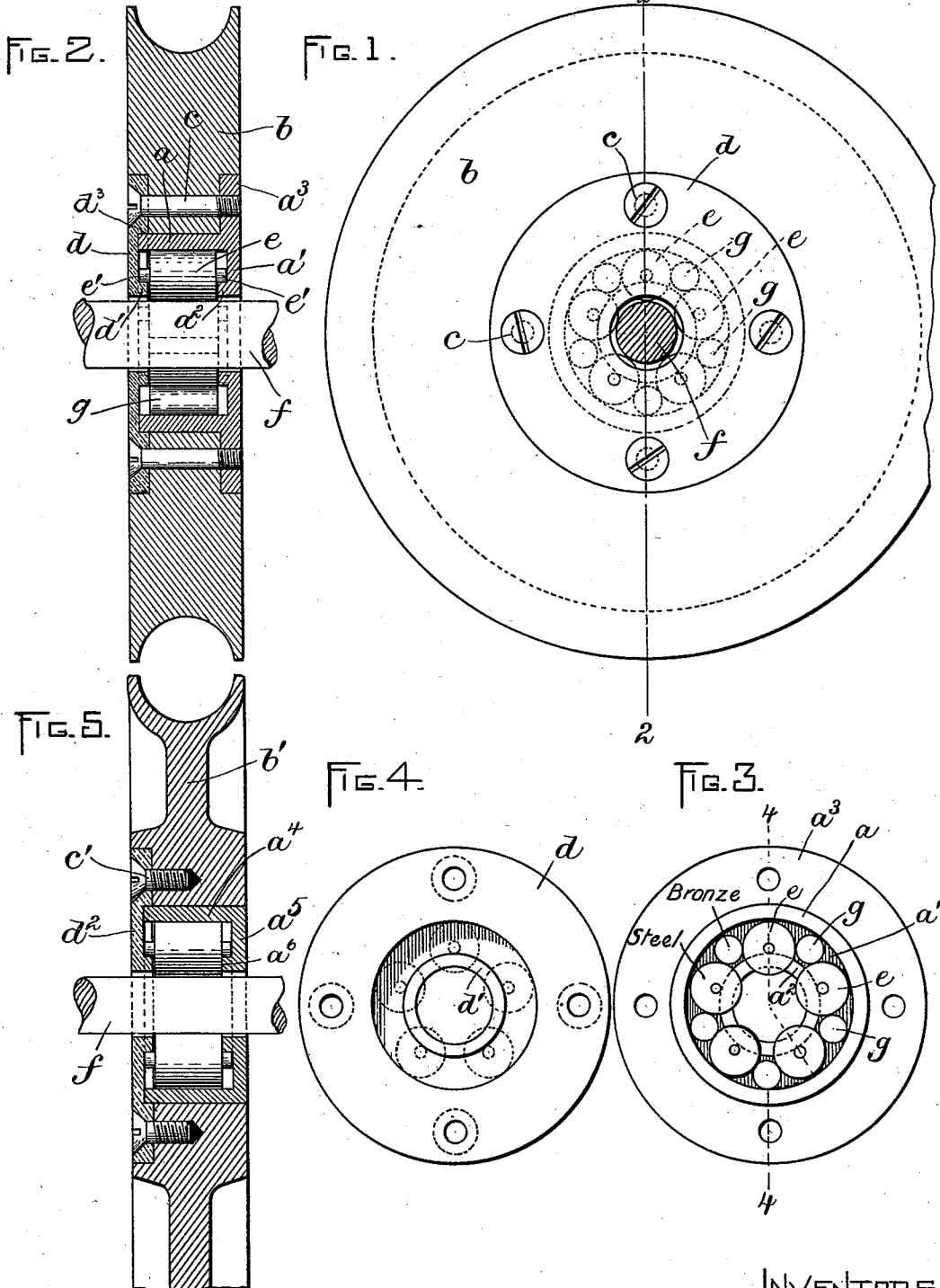

WITNESSES:

E. Batchelder
Rollin Abell.

INVENTORS:

F. C. Pitcher
A. J. Q. Knowlton
by Wright, Brown & Quincy
Attys.

UNITED STATES PATENT OFFICE.

FRANK C. PITCHER, OF MEDFORD, MASSACHUSETTS, AND ALONZO J. Q. KNOWLTON, OF CAMDEN, MAINE, ASSIGNORS TO THE DUPLEX ROLLER BUSHING COMPANY, OF CAMDEN, MAINE.

ROLLER-BUSHING FOR SHEAVES.

SPECIFICATION forming part of Letters Patent No. 549,686, dated November 12, 1895.

Application filed March 11, 1895. Serial No. 541,216. (No model.)

To all whom it may concern:

Be it known that we, FRANK C. PITCHER, of Medford, in the county of Middlesex and State of Massachusetts, and ALONZO J. Q.

KNOWLTON, of Camden, in the county of Knox and State of Maine, have invented certain new and useful Improvements in Roller-Bushings for Sheaves, of which the following is a specification.

This invention relates to that class of roller-bushings for sheaves or pulleys in which a series of rollers are held in position around the shaft or spindle on which the sheave rotates by means of a casing secured to the sheave and forming the core or central portion thereof. The casing is made as a separate piece from the main body of the sheave and is inserted therein and secured thereto by suitable means, such as screws or rivets. As the casing has to sustain the load supported by the pulley, it is important that it be of strong and durable construction, not liable to be broken. It is at the same time important that the casing be constructed, in such manner that it can readily be opened to permit access to the rollers for the purpose of removing worn or broken ones, inserting new ones, and for similar purposes, as they are removable and interchangeable.

Our invention has for its object to provide a roller-bushing, comprising a casing and a series of rolls held thereby in circular order, in which the casing shall have the requisite strength and at the same time be capable of affording ready access to the rollers.

To this end the invention consists in the improvements which we will now proceed to describe and claim.

Of the accompanying drawings, forming a part of this specification, Figure 1 represents a side elevation of a sheave provided with our improvements, the construction being of the kind ordinarily used with wooden sheaves. Fig. 2 represents a section on line 2 2 of Fig. 1.

Fig. 3 represents a view of the inner side of the casing constructed as shown in Fig. 1, the cap applied to the casing being removed. Fig. 4 represents a view of the inner side of the cap or annular cover of the casing constructed as shown in Figs. 1 and 2.

Fig. 5 represents a sectional view similar to Fig. 2, but showing the preferred construction when a metal sheave is employed.

The same letters of reference indicate the same parts in all the figures.

Referring for the present to Figs. 1, 2, 3, and 4, *a* represents a cylindrical metal casing formed to be inserted in a chamber or opening prepared for its reception in a wooden sheave *b*, the casing *a* being open at one end across its entire internal diameter and having at its opposite end an inwardly-projecting flange *a'*, on the inner edge of which is formed an annular rib *a''*, formed to engage the trunnions on the rollers, hereinafter described, the same end of the casing having also an outwardly-projecting flange *a'''*, which is of larger diameter than the casing and is formed to bear against one side of the sheave and has orifices to receive attaching-screws *c*, by which the casing may be secured to the sheave.

d represents an annular cap or cover which has an inwardly-projecting bead *d'* on its inner edge and is of such diameter that its outer edge projects outwardly beyond the periphery of the casing *a*, the cap *d* being preferably of about the same diameter as the flange *a'''* of the casing. The outer portion of the cap *d* is provided with screw-holes, said holes being preferably arranged to register with the holes in the flange *a'''*, so that the cap and flange can both be attached by the same screws *c*, as shown in Fig. 1. The cap *d* is attached wholly by the screws *c*, and when said screws are removed the cap is loosened and can be readily removed from the casing and from the sheave. The inner side of the cap *d* is recessed to form an abutment *d''*, which bears on the outer surface of the casing *a* at the open end of the latter and prevents said casing from spreading at its open end under the pressure to which it is subjected when in use.

e e represent rollers, which are interposed between the inner surface of the casing *a* and the shaft or spindle *f*, on which the sheave rotates, said rollers being provided at their ends with trunnions *e' e'*, which are engaged with the ribs *a''* and *d''*, as shown in Fig. 2, the

said ribs holding the rollers in place in the casing. Smaller rollers *g* may be interposed between the rollers *e*, said rollers *g* bearing on the inner surface of the casing *a*, as shown in Figs. 1 and 3.

It will be seen that the cap *d*, formed to cover and prevent the spreading of the open end of the casing *a* and made readily separable therefrom and attached wholly by screws outside of the periphery of the casing, not only enables the casing to be made strong and durable, its continuity being unbroken by screw-threads or other attaching devices, but also enables the roller-receiving space to be readily uncovered to permit access to the rollers by the removal of the cap *d*.

Heretofore the casing of a roller-bushing of this class has been made of two separable sections, one of which screws onto the other, the cylindrical part of the casing being divided and one part provided with an external and the other with an internal screw-thread, this construction requiring the rotation of one part of the casing in order to uncover the rollers. This construction is objectionable because it weakens the casing, rendering it liable to be enlarged by the pressure exerted upon it, and further because the screw-threads are liable to be caused to adhere to each other by the spreading of the casing and by rust and corrosion, so that the separation of the parts of the casing is liable to be a matter of great difficulty, if not an entire impossibility.

It will be seen that by making the cap *d* with the abutment *d*² and without any direct attachment to the casing and securing it only by screws which can be readily removed and whose removal will not be materially impeded by rust or corrosion we obviate the objections above mentioned.

In Fig. 5 we show the preferred construction when a metallic sheave *b*¹ is used. In this case a cylindrical casing *a*⁴ is made without an outwardly-projecting flange and has only an inwardly-projecting flange *a*⁵, formed like the flange *a*¹ and provided with an inwardly-projecting rib *a*⁶ like the rib *a*². The casing is in this case driven or pressed tightly into the orifice formed for its reception in the sheave and is held by the tightness of its fit in said orifice, so that attaching-screws are not required to screw the casing in place. The cap *d*² is constructed in all respects like the cap *d* above described, and is secured to the sheave by screws *c*¹ passing through the holes in the outer portion of the cap, said

holes being outside of the periphery of the casing, so that the cap can be readily unfastened and moved to permit access to the rollers.

The rolls *e e* are preferably made of steel, and the smaller rolls *g*, which are used only to separate the rolls *e* from each other, are made of bronze, so that they will not rust, and therefore will not adhere to the rolls *e* in case the surfaces of the later become rusted. The bronze rolls act to clean or wear off any accumulations of rust that may form on the surfaces of the steel rolls, said bronze rolls being always free from rust and in good working condition.

It will be seen that the conjoint use of the steel bearing-rolls to support the strain incidental to the use of the pulley or sheave and the bronze rolls to separate the steel rolls and keep them free from rust increases the effectiveness and durability of the bushing.

We claim—

1. A sheave or pulley having a central cavity, a bushing or casing inserted in said cavity and having at one end an integral inwardly projecting flange forming the fixed end of a roller-holding space within said casing, and an annular end-piece or cap of larger diameter than the casing and attached outside the casing to the pulley, a series of rolls located in said casing, said end-piece constituting the removable end of the roller-holding space and having an abutment that surrounds and prevents the spreading of the open end of the casing.

2. A sheave or pulley having a central cavity, a bushing or casing inserted in said cavity and having suitable roller-confining ends or flanges one of which is removable, a series of steel bearing-rolls located in said casing, and a series of separating rolls of an oxidizable metal such as bronze interposed between said bearing-rolls.

In testimony whereof we have signed our names to this specification, in the presence of two subscribing witnesses, respectively, the 6th and 8th day of March, A. D. 1895.

FRANK C. PITCHER.

ALONZO J. Q. KNOWLTON.

Witnesses to F. C. P.:

C. F. BROWN,

E. BATCHELDER.

Witnesses to A. J. Q. K.:

M. T. CRAWFORD,

G. H. TALBOT.