

(No Model.)

3 Sheets—Sheet 1.

F. L. BRYANT. BORING MACHINE.

No. 443,666.

Patented Dec. 30, 1890.

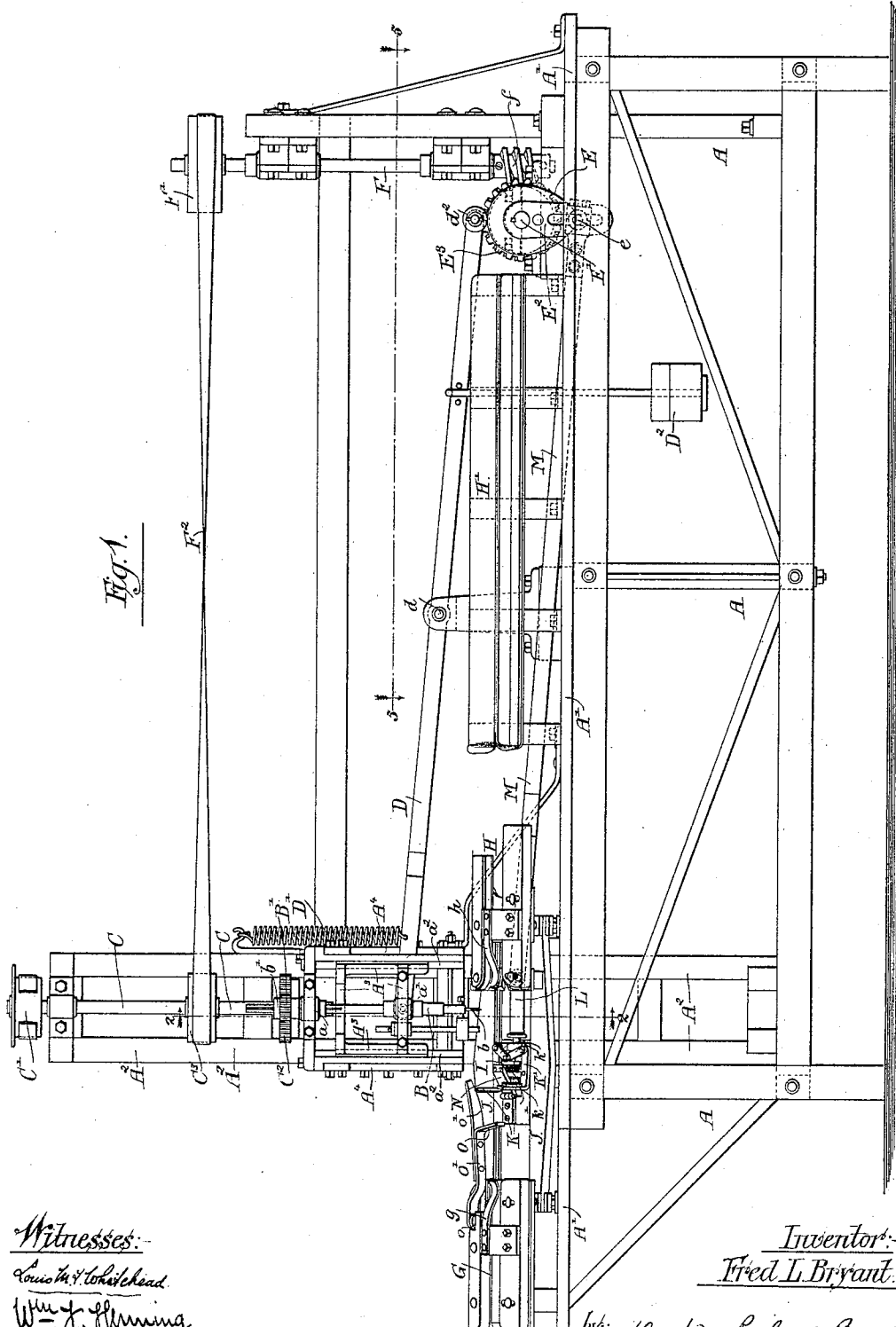

Fig. 1.

Witnesses:
Louis M. Whitehead.
Wm. J. Fleming

Inventor:
Fred L. Bryant.
 by: *Clayton, Poole & Brown*
Attorneys.

F. L. BRYANT.
BORING MACHINE.

No. 443,666.

Patented Dec. 30, 1890.

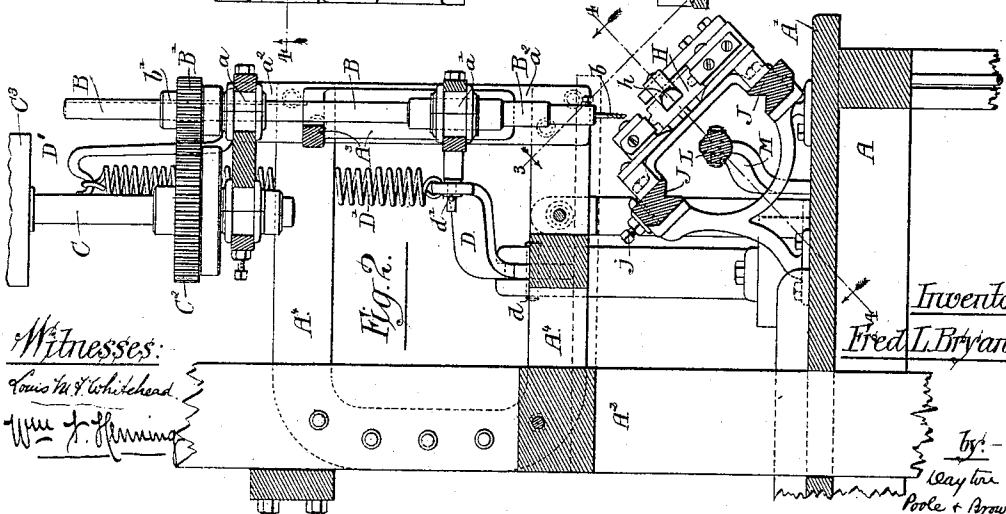
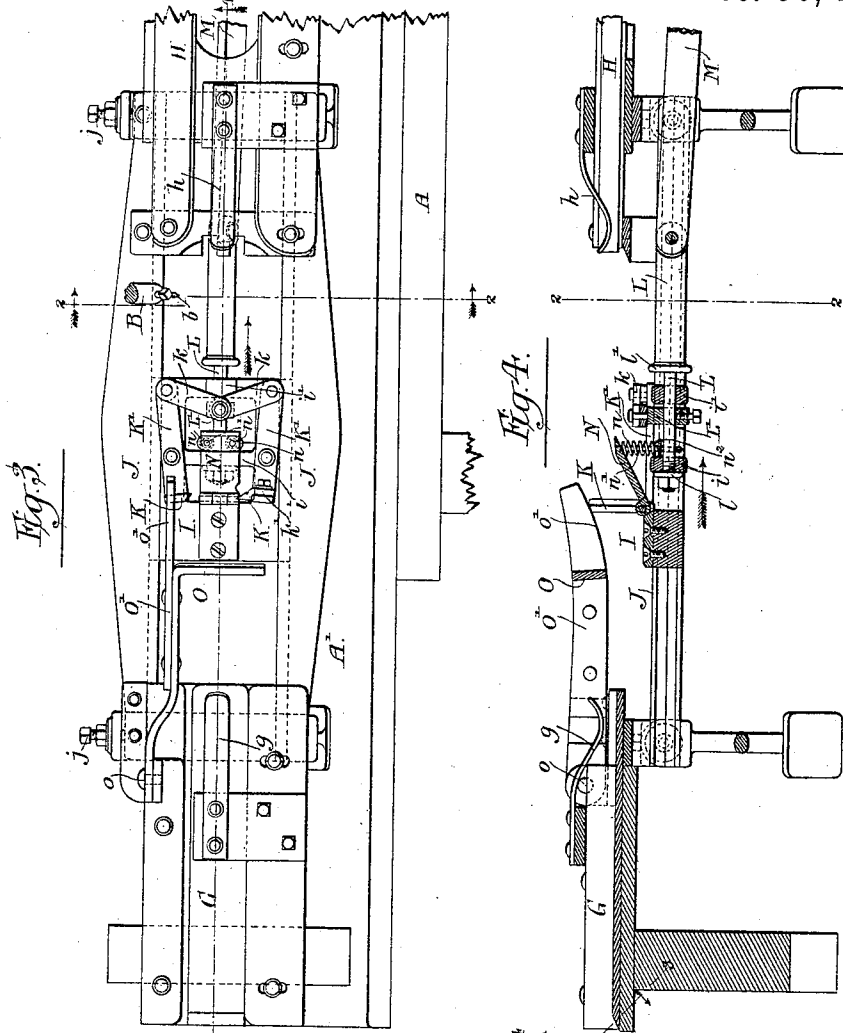

Witnesses:
Louis W. Whitehead
Wm. J. Fleming

Inventor:
Fred L. Bryant

By:
Rayton
Pooler & Brown
 Attorneys

F. L. BRYANT.
BORING MACHINE.

No. 443,666.

Patented Dec. 30, 1890.

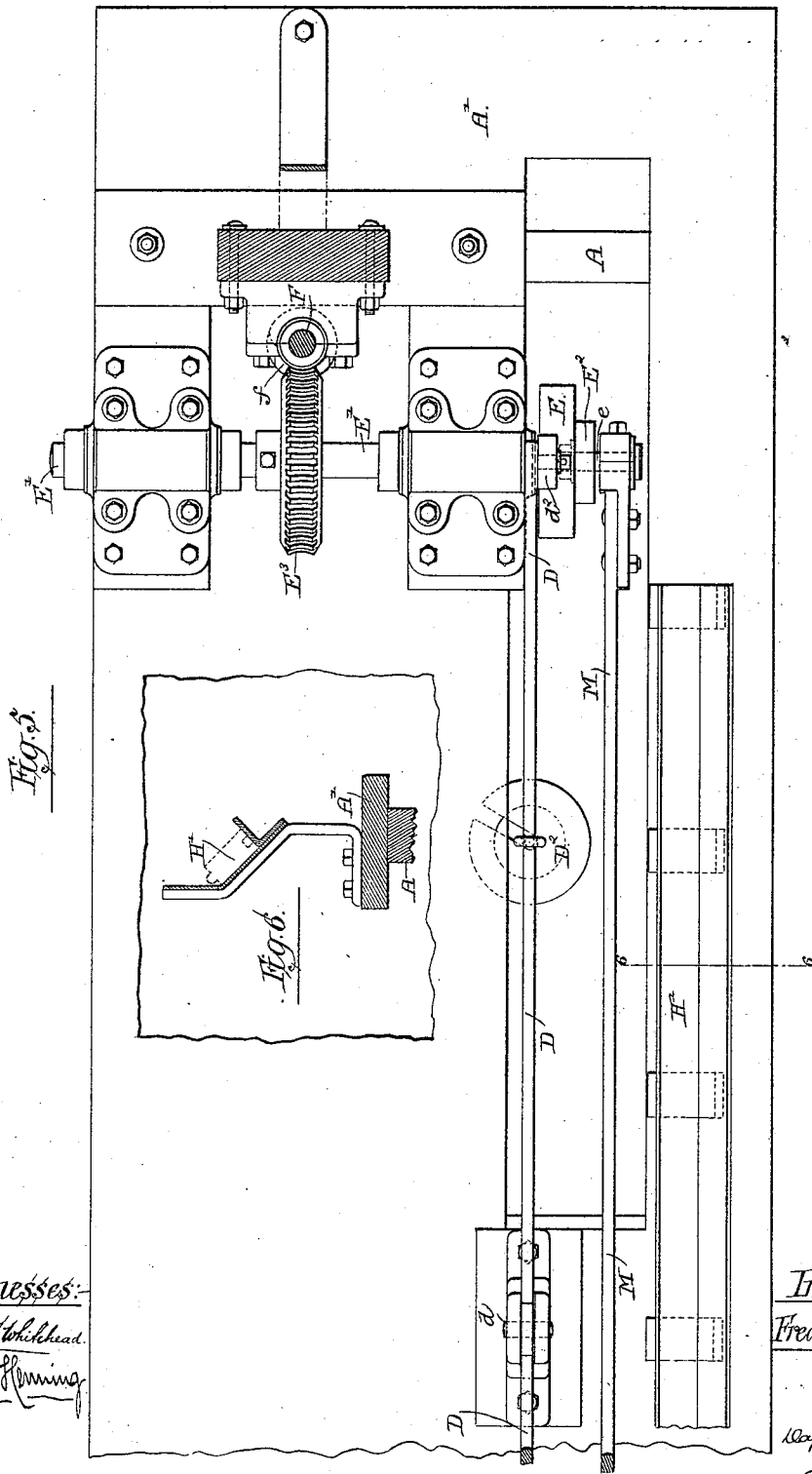
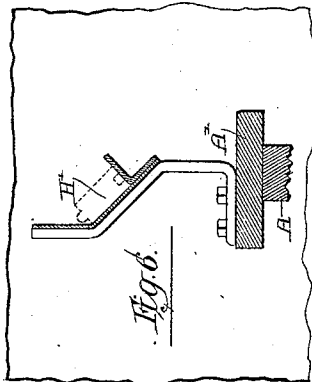

Fig. 5.



Witnesses:
Wm. H. Whitehead
Wm. J. Fleming

Inventor:
Fred. L. Bryant

By:
Wayles, Poole & Brown
 Attorneys.

UNITED STATES PATENT OFFICE.

FRED L. BRYANT, OF CHICAGO, ILLINOIS.

BORING-MACHINE.

SPECIFICATION forming part of Letters Patent No. 443,666, dated December 30, 1890.

Application filed October 29, 1888. Renewed November 11, 1890. Serial No. 371,047. (No model.)

To all whom it may concern:

Be it known that I, FRED L. BRYANT, of Chicago, in the county of Cook and State of Illinois, have invented certain new and useful
5 Improvements in Boring-Machines; and I do hereby declare that the following is a full, clear, and exact description thereof, reference being had to the accompanying drawings, and to the letters of reference marked thereon,
10 which form a part of this specification.

This invention relates to an improvement in machines for boring a series of holes at equal intervals in wooden strips.

The machine herein shown is more especially intended for boring nail-holes in hardwood flooring-strips, and for this purpose is constructed to sustain the strips in an oblique position with reference to the boring-tool, so as to bore inclined holes in the flooring-strips.

The invention consists in the matters hereinafter described, and pointed out in the appended claims.

As shown in the said drawings, Figure 1 is a front elevation of a machine embodying the invention. Fig. 2 is an enlarged cross-section of the same, taken upon line 2 2 of Fig. 1. Fig. 3 is an enlarged detail plan view of the parts of the machine adjacent to the boring-tool, taken upon the line 3 3 of Fig. 2.
30 Fig. 4 is a longitudinal section taken upon line 4 4 of Figs. 2 and 3. Fig. 5 is a detail plan view taken upon line 5 5 of Fig. 1. Fig. 6 is a detail section taken upon line 6 6 of Fig. 5.

As illustrated in the said drawings, A is the main frame of the machine, herein shown as made of wooden posts and stringers and as having a horizontal top A'.

A² is a vertical frame-standard attached to the side of the main frame A, and affording bearings for the moving parts by which the boring-tool is actuated.

B is a vertically-arranged spindle, to the lower end of which is secured a boring-tool
45 *b*. Said spindle is mounted in bearings *a a'* on the frame-standard A², and is provided at its upper end with a gear-pinion B', which is mounted upon a sleeve *b'*, having a spline engaging a longitudinal groove in the shaft, so that the shaft may slide freely endwise
50 through said sleeve, but will be turned when the pinion and sleeve are rotated.

C is a counter-shaft arranged parallel with the spindle B, and provided at its upper end with a belt-pulley C', over which is placed a
55 belt, by which motion is transmitted to the machine. Upon the said shaft C is secured a gear-wheel C², intermeshing with the gear-pinion B' of the spindle B. Said shaft C is also provided with a second belt-pulley C³, over which passes
60 a belt for conveying motion to another part of the machine, as will be hereinafter described.

The bearing *a'* of the shaft B is mounted in a vertically-sliding frame A³, which is
65 mounted in fixed vertical guides *a² a³* upon the frame-standard A². Said guides are herein shown as supported by U-shaped metal brackets A⁴ A⁴, bolted to said frame-standards in the manner illustrated in the draw-
70 ings.

D is a rocking lever, which is arranged in a horizontal position and supported upon a pivot *d*, located near its middle. Said lever is pivotally connected at one of its ends with
75 the sliding frame A³, by means of a pivot-stud *d'*, attached to said sliding frame. At its opposite end said lever D is provided with an anti-friction roller *d²*, which engages with a cam E, affixed to a revolving shaft E', said
80 cam serving to give oscillatory movement to the said rocking lever, and to thereby move the boring-tool vertically.

D' is a spring acting upon the lever D in a direction to hold the said lever in engagement
85 with the surface of the cam E and operating to sustain the boring-tool at the upward limit of its movement. D² is a weight which is hung from the end of said lever D, adjacent to the cam E, and which serves to counter-
90 balance the weight of the sliding frame A³ and connected parts. The shaft E may be driven in any suitable manner; but as herein shown is provided with a worm-wheel E², Fig. 5, which is engaged by a worm *f* upon a vertical
95 shaft F, which shaft is provided in its upper part with a belt-pulley-F', by which the said shaft is driven from the shaft C by means of a belt F², placed around said pulley F' and a pulley C³ upon said shaft C.
100

Devices for guiding the strips to be bored to and from the boring-tool and for automatically feeding forward said strips are herein shown, as follows: G is a guide in which the

strips are held as they approach the boring-tool, said guide being made of **U** shape and arranged in an oblique or inclined position, so as to sustain the strip obliquely with refer-
 5 ence to the boring-tool. Said guide is desirably provided with a spring-presser *g* acting to hold the strip closely in contact with the lower surface of the guide. **II** is a second similar guide, receiving the strip after it has
 10 passed the boring-tool, said guide being also made of **U** shape and provided with a pressing-spring *h*, which acts upon the strip to hold the same in contact with the bottom of the guide. Said springs *g h* obviously hold the
 15 strip from being lifted out of place by the action of the boring-tool as the latter is withdrawn after the boring of the holes. **II'** is an auxiliary guide for sustaining the strips after the same leave the guide **H**, said guide **II'**
 20 consisting of a simple **V**-shaped trough supported in alignment with the guides **G** and **H**, as clearly shown in Figs. 1, 5, and 6.

Devices for automatically gripping and moving forward the strip after each hole is
 25 bored are provided, as follows: **I** is a sliding frame or carriage mounted in stationary parallel guide pieces or ways **J J**. On the said carriage are mounted two grippers **K K**, which are located at opposite sides of the path of
 30 the strip and are mounted upon the ends of levers **K' K'**, which are pivoted at points between their ends to the carriage **I**. Said carriage reciprocates in a plane below and parallel with the surface of the strip to be
 35 bored, and the grippers **K K** extend upwardly from said carriage in position to engage opposite edges of the strip when the grippers are brought toward each other. *k k* are two
 40 toggle-arms connected with the gripper-levers **K' K'** at the ends thereof remote from the grippers. Said toggle-arms are pivotally connected with each other and with a block or collar **L'**, affixed to a longitudinally-sliding rod
 45 **L**, which has bearings in two cross-pieces *i i'* of the sliding frame **I**. *l l'* are collars or shoulders upon the rod **L**, which are placed upon said rod outside of the cross-bars *i i'*, and at such distance apart as to allow a limited longitudinal
 50 sliding movement of the said rod in the cross-bars. The collar **L'**, to which the toggle-arms *k k* are pivoted, is so located with reference to the outer ends of the gripper-arms that
 55 when the rod **L** is thrust backwardly or toward the guide **G** the toggle-arms will be flexed, the ends of the gripper-arms, to which said toggle-arms are connected drawn together and the grippers separated to release
 60 the strip. When said rod **L** is thrust or moved in the opposite direction, or in the direction in which the strip is fed or moved, the toggle-arms will be straightened out and the grippers brought in contact with the strip, so as to hold or clamp the latter and carry the same forward.

65 Bodily movement is given to the carriage **I** solely through the medium of the sliding rod **L**, which acts upon the grippers in the

manner described, so that the carriage will not be bodily moved in either direction until the grippers have been opened or closed in
 70 the manner described. For giving motion to the said carriage and the grippers, the crank-shaft **E'** is provided with a crank-arm **E²**, provided with a crank-pin *e*. A connecting-rod
 75 **M** is engaged at one end with said crank-pin and is pivoted at its opposite end to the rod **L**, thereby giving a longitudinal reciprocatory motion to said rod **L** and to the carriage
 80 **I** during the operation of the machine. In the backward movement of the carriage the gripper-levers **K' K'** will be thrust or thrown outwardly under the action of the rod **L**, and said rod will be thrust forward to the limit of
 85 its movement in the carriage, so that the collar *l'* will bear against the cross-piece *i'*, and thereby act against the carriage and move the latter with a positive movement. In the forward or return stroke the grippers will engage the strip before the collar *l* engages the
 90 cross-piece *i*, so that the end pull of the rod **L** in moving the carriage is exerted upon the said gripper to hold the latter in contact with the strip. In other words, in feeding the strip forward the rod **L** pulls directly upon the
 95 strip through the medium of the gripping mechanism, the carriage being moved by its connection with the gripping-levers. The collar *l* will of course rest against the cross-piece *i* and act by direct pressure to move the carriage when there is no strip in the machine. 100

In order to provide for the carrying forward of the rear end of a strip past the boring-tool when the previous movement of the gripping device has carried the strip so far
 105 forward that the rear end thereof will stand in front of and will not be acted upon by the grippers, a spring-pawl is employed which is thrown up into the path of the strip by a spring, but is adapted to yield downwardly and allow the passage of the strip over it in
 110 the usual operation of the machine. Such pawl is indicated at **N**, Figs. 1, 3, and 4, and is herein shown as pivoted to the rear part of the carriage **I** and as extending forwardly and upwardly, with its free end in position to
 115 strike the rear end of a strip and carry the same forward beyond the boring-tool in the advance movement of the carriage. Spiral springs *n n* are placed upon sliding rods *n' n'*, secured to the free end of the pawl, said
 120 springs being located between the pawl and a cross-bar *n²* upon the carriage for lifting the free end of the said pawl **N**. In thrusting a strip to be bored into the machine the forward end of the strip upon encountering the
 125 said pawl **N** will depress the same and the pawl will continue to bear upwardly against the under surface of the strip until the strip is carried forward to such point that the pawl will pass from beneath the strip in the back-
 130 ward movement of the carriage, when the next subsequent forward movement of the carriage will carry the rear end of the strip forward by the action of said pawl on the end

surface of the strip, in the manner above described.

It is obviously desirable that the first hole of a series of holes to be bored in a strip shall be located in every instance at the same distance from the end of the strip, and it is especially desirable that the first hole made shall not be a greater distance from the advance end of the strip than the distance between holes subsequently formed. In order that the point at which the first hole is bored shall not be dependent solely upon the manner in which the strip is inserted by the operator, an automatically-acting stop is herein provided, against which the advance end of the strip may be placed in thrusting it into the machine, said stop being lifted or carried out of the path of the board, so as to allow the grippers to engage and move forward the strip by gripping every strip the same distance from its advance end. As shown in the said drawings, O is a detent which is located across the path of the board in advance of the guide G, between said guide and the boring-tool. Said stop is herein shown as mounted upon an arm O', pivoted at o to the machine-frame. The said arm O' is provided with a cam projection o', which is located over the path of one of the grippers K, and is so arranged that said gripper will strike the lower cam-surface of said arm, and thereby lift the stop in the backward movement of the grippers. Said stop O, furthermore, is so located that the grippers will pass to the rear of the same at each reciprocation of the carriage. In feeding the strips to the machine the forward end of each strip is thrust through the guide G until it comes in contact with the stop O, and the strip remains immovable until a subsequent movement of the carriage I brings the top of the gripper K in contact with the cam-arm o' and lifts the stop above the path of the strip. The gripper then passes to the rear of the strip, and after engaging the strip moves forward with the same, the said stop resting and sliding upon the top of the strip as the latter is fed forward beneath it in subsequent movements of the carriage and grippers. I have for convenience arranged one of the grippers K to strike the cam-arm o'; but it will of course be understood that any other piece or part upon or moving with the carriage I may be employed to engage said cam-arm with the same result.

The lower walls of the guides G and H for the strips will preferably be made adjustable or movable, as shown, in order to enable the machine to operate on strips of different widths. For the same purpose the gripping-jaws K K have a movable or adjustable section k', Fig. 3, which may be moved inwardly or outwardly to correspond with the width of the strip being operated upon.

It is of course necessary, in order that the jaws should be opened by the sliding of the rod L in the carriage I, that said rod and

parts connected therewith should move more easily than the carriage I moves in its guides, and to insure a sufficient amount of frictional resistance between the said carriage and guides at all times the guides are made adjustable toward and from each other, so that the guides may be tightened against the carriage when necessary for this purpose. In the particular construction shown, Figs. 1 and 3, set-screws j j, acting against the outer edges of one of the guides J, which is movable, are used for so tightening the guides against the carriage.

One of the principal features of my invention is embraced in a construction wherein bodily reciprocating gripping-jaws are employed for feeding forward the strip, in connection with automatic devices operating to open and close said jaws at each limit of the reciprocatory motion thereof, and this construction is herein broadly claimed. The particular construction illustrated by which the jaws are actuated for gripping the strip and releasing it by a device which also gives bodily movement to the jaws is, however, of special advantage, and is herein specifically claimed as part of my invention.

I claim as my invention—

1. The combination, with a reciprocating boring-tool, of means for feeding forward a strip beneath the tool, comprising a stationary guide for the strip, a gripping device embracing jaws movable to grip the strip, and means for reciprocating said gripping device, also connected with and actuating said jaws, substantially as described.

2. The combination, with a reciprocating boring-tool, of means for feeding a strip past the tool, comprising stationary guides, a reciprocating carriage, gripping-jaws mounted upon said carriage, a sliding rod mounted in the carriage and connecting with and actuating said jaws and carriage, and means for moving said sliding rod, whereby motion is imparted to said carriage and jaws, substantially as described.

3. The combination, with a reciprocating boring-tool, of means for feeding past the tool a strip to be bored, comprising stationary guides for the strip, a reciprocating carriage, gripping-jaws mounted upon the carriage, toggle-arms connected with the said jaws, a longitudinally-sliding rod mounted upon the carriage and connected with the toggle-arms, and means connected with the sliding rod whereby said carriage and jaws are actuated, substantially as described.

4. The combination, with a reciprocating boring-tool, of a feeding device for a strip to be bored, comprising a reciprocating carriage and gripping-jaws thereon, and a yielding or spring pawl mounted on the carriage adapted to engage the rear end of the strip, substantially as described.

5. The combination, with a reciprocating boring-tool and a feeding device comprising a reciprocating carriage and gripping-jaws

thereon, of a stop movable into and out of the path of the strip, a cam-arm connected with the stop, and a piece or part attached to or moving with the said carriage acting upon said
5 cam-arm to move the stop out of the path of the strip, substantially as described.

6. The combination, with a reciprocating boring-tool, of means for feeding forward a strip beneath the tool, comprising a stationary
10 guide for the strip, longitudinally-movable gripping-jaws, also laterally movable to en-

gage the strip, and means for reciprocating the jaws, connected with and automatically actuating the jaws at each limit of the bodily movement thereof.

In testimony that I claim the foregoing as my invention I affix my signature in presence
15 of two witnesses.

FRED L. BRYANT.

Witnesses:

C. CLARENCE POOLE,
F. W. JENKINS.