

I. Rood,
Barrel Machine.

No. 110,871.

Patented Jan. 10, 1871.

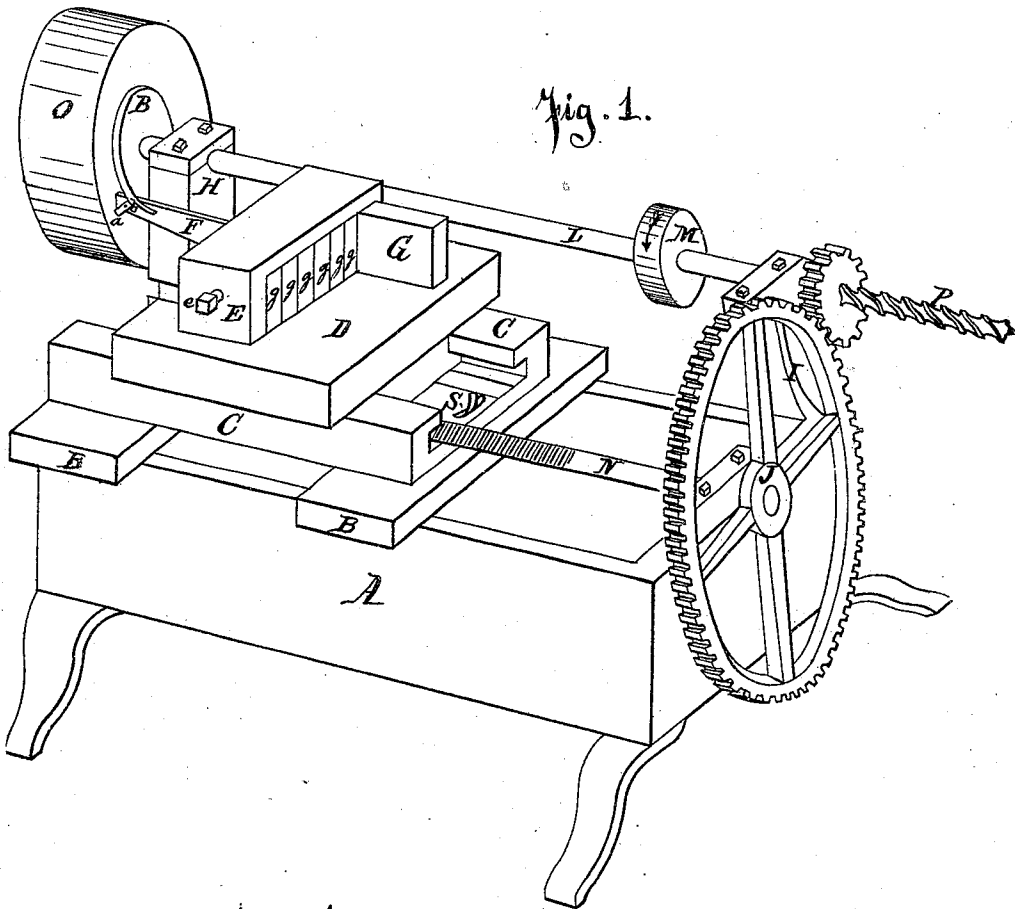

Fig. 1.

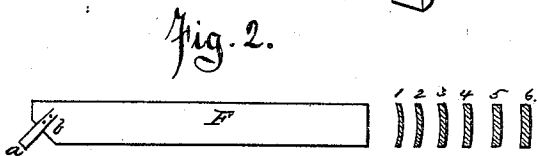

Fig. 2.

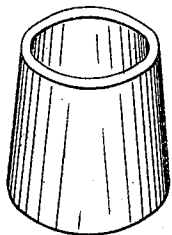

Fig. 3.

Witnesses.
L. B. Smith.
L. F. Ware

Inventor.
Ira Rood

United States Patent Office.

IRA ROOD, OF ELYRIA, OHIO.

Letters Patent No. 110,871, dated January 10, 1871.

IMPROVEMENT IN LATHES FOR TURNING WOOD.

The Schedule referred to in these Letters Patent and making part of the same.

I, IRA ROOD, of Elyria, county of Lorain and State of Ohio, have invented certain Improvements in Machinery for Turning Cylindrical Cones from Blocks of Solid Wood, whereby hollow wooden ware can be made of superior excellence, of which the following is a specification.

This invention relates to a wood-turning lathe, and consists in the construction and arrangement of devices hereinafter more fully described and shown.

Description of Drawing.

Figure 1 is a perspective drawing of my machine.

Figure 2, side view of one of cutting-tools and shank, and sections of several tools.

Figure 3 shows one of the cones as removed from the block.

General Description.

A is the frame of machine, which should be made substantial, so as to resist vibrations.

Cross-pieces B and B are cast on and make part of the bed-frame of the machine.

C and C are grooved ways, accurately planed and fitted.

These ways are united strongly together, and the end under F is bolted down to the frame.

The other end, shown at S, has a slot and binding-screw, so as to set the ways at any angle with the main shaft L.

D is closely fitted to the slides C and C, so as to move without play, and smoothly.

A stud is shown at e, on which a lever is hung (not shown in the drawing,) carrying a half-nut, that, when held on the screw N, drives the slide D forward.

E is the tool-holder proper, so arranged that any required number of tools may be set with separating-blocks, and all clamped firmly by the binding-screw e, as shown at g g g g, &c.

F shows one of the tools set out and ready for use. Any number of them may be set to act together, or drawn back, as shown at G.

Fig. 2 shows a separate view of one of the tools, with its knife a attached at b.

1, 2, 3, 4, 5, and 6 are sections of several tools curved, to suit several cones they are to cut off the log of wood.

L is a mandrel or main driving-shaft, with its pulley M, and at its left end is fitted with a flange or collar, in which are set a number of spurs, to hold the block from turning. At the extreme end it is fitted with nut and left-hand screw.

The block O is cut from the tree of suitable length for forming washing-tubs, butter-firkins, &c., bored lengthwise through its center, and secured on the mandrel by the nut and screw.

P is an auger, fitted to the end of the mandrel for boring blocks.

K is a pinion keyed on the main shaft L, and meshing into the cog-wheel I, which turns the screw N, and is so geared that the tool F is carried about the one thirty-second part of an inch with each revolution of the shaft L.

The mode of operating with this machine is as follows:

The shaft L is made to revolve rapidly in the direction of the feathered arrow on M, when the handle of the lever carrying the half-nut is pressed down, so as to act on the left-hand screw N. This screw causes the tool to advance regularly, and cuts off a conical shell, or several of them together, like that shown in fig. 3.

The cutting-point is somewhat similar to the hook-tool used in wooden-bowl turning, and removes the shaving readily.

The shells turned from this machine make hollow-ware of superior quality, and without staves.

Claim.

I claim as my invention—

The construction and arrangement of mandrel L, with its bearing-tool P, chuck K, and automatic adjustable slide-rest, as herein shown and described.

IRA ROOD.

Witnesses:

L. B. SMITH,
JOHN C. HALL.