

(19) World Intellectual Property Organization
International Bureau



(43) International Publication Date
10 September 2004 (10.09.2004)

PCT

(10) International Publication Number
WO 2004/077233 A2

- (51) International Patent Classification⁷: **G06F**
- (21) International Application Number: PCT/US2004/004089
- (22) International Filing Date: 11 February 2004 (11.02.2004)
- (25) Filing Language: English
- (26) Publication Language: English
- (30) Priority Data: 10/371,958 21 February 2003 (21.02.2003) US
- (71) Applicant (for all designated States except US): **IGT** [US/US]; 9295 Prototype Drive, Reno, NV 89521 (US).
- (72) Inventors: **MICHAELSON, Richard, E.**; 555 Werth Circle, Reno, NV 89506 (US). **BANSEMER, Mark, W.**; 673 Silver Falls Court, Reno, NV 89511 (US).
- (74) Agent: **MASIA, Adam, H.**; Bell, Boyd & Lloyd LLC, P.O. Box 1135, Chicago, IL 60690-1135 (US).
- (81) Designated States (unless otherwise indicated, for every kind of national protection available): AE, AG, AL, AM, AT, AU, AZ, BA, BB, BG, BR, BW, BY, BZ, CA, CH, CN, CO, CR, CU, CZ, DE, DK, DM, DZ, EC, EE, EG, ES, FI, GB, GD, GE, GH, GM, HR, HU, ID, IL, IN, IS, JP, KE, KG, KP, KR, KZ, LC, LK, LR, LS, LT, LU, LV, MA, MD, MG, MK, MN, MW, MX, MZ, NA, NI, NO, NZ, OM, PG, PH, PL, PT, RO, RU, SC, SD, SE, SG, SK, SL, SY, TJ, TM, TN, TR, TT, TZ, UA, UG, US, UZ, VC, VN, YU, ZA, ZM, ZW.
- (84) Designated States (unless otherwise indicated, for every kind of regional protection available): ARIPO (BW, GH, GM, KE, LS, MW, MZ, SD, SL, SZ, TZ, UG, ZM, ZW), Eurasian (AM, AZ, BY, KG, KZ, MD, RU, TJ, TM), European (AT, BE, BG, CH, CY, CZ, DE, DK, EE, ES, FI, FR, GB, GR, HU, IE, IT, LU, MC, NL, PT, RO, SE, SI, SK, TR), OAPI (BF, BJ, CF, CG, CI, CM, GA, GN, GQ, GW, ML, MR, NE, SN, TD, TG).

[Continued on next page]

(54) Title: CENTRAL DETERMINATION GAMING SYSTEM WHERE THE SAME SEED IS USED TO GENERATE THE OUTCOMES FOR A PRIMARY GAME AND A SECONDARY GAME

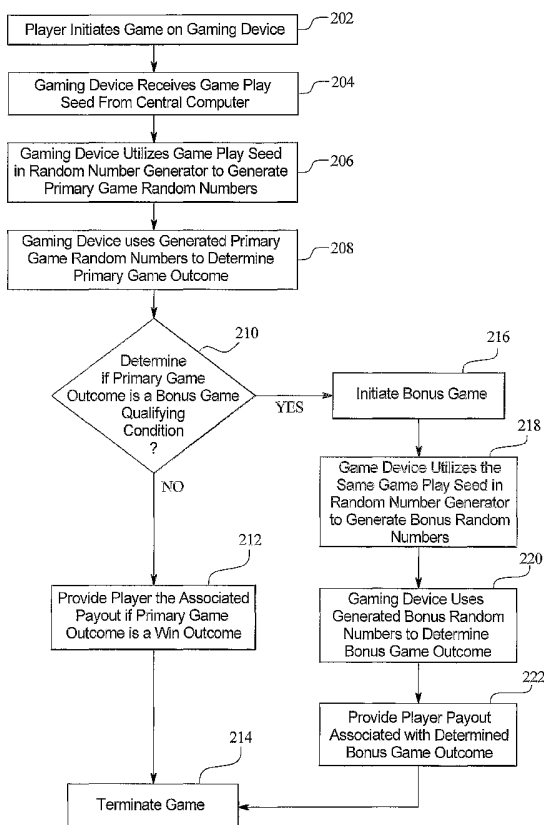

(57) Abstract: A central determination gaming system wherein the same random number or game play seed is used to generate a primary or base game outcome and a secondary or bonus game outcome. The present invention includes a central computing system in communication with a plurality of gaming devices. The central computing system maintains one or more predetermined pools or sets of random number or game play seeds. In one embodiment, each game play seed is deterministic of a primary wagering game outcome and a secondary game outcome. That is, each gaming device is operable to utilize a game play seed to determine both the primary wagering game outcome and the secondary game outcome.

WO 2004/077233 A2



Published:

— without international search report and to be republished upon receipt of that report

For two-letter codes and other abbreviations, refer to the "Guidance Notes on Codes and Abbreviations" appearing at the beginning of each regular issue of the PCT Gazette.

SPECIFICATION

TITLE OF THE INVENTION

**“CENTRAL DETERMINATION GAMING SYSTEM WHERE THE SAME SEED
IS USED TO GENERATE THE OUTCOMES FOR A PRIMARY GAME AND A
SECONDARY GAME”**

5

BACKGROUND OF THE INVENTION

The present invention relates in general to a central determination gaming system, and more particularly to a central determination gaming system where the same game play seed is used to generate the outcomes for a primary game and a secondary game. The majority of the contemporary wagering gaming devices, such as slot machines, randomly generate awards and other outcomes. Such gaming devices typically include a relatively low probability associated with obtaining the highest award, relatively medium probabilities associated with obtaining medium range awards and relatively higher probabilities associated with obtaining low range awards. These gaming devices also include probabilities associated with obtaining losses or no award at all. The probabilities of obtaining the awards and the amount of the awards determine the average expected pay out percentage of these wagering gaming devices. Because the outcomes of these gaming devices are completely randomly determined, there is no certainty that a player will ever obtain any particular award. That is, no matter how many times a player plays the game, since the gaming device generates outcomes randomly or completely based upon a probability calculation, there is no certainty that the game will ever provide the player with a rare outcome, such as a jackpot award, or any other specific value for that matter. On the other hand, due to the random determination, the gaming device can provide the rare outcomes, such as jackpot awards, numerous times in a small number of plays. For example, a probability-based \$1 slot machine gaming device may be programmed to payback 95% of all wagers placed with a 1% chance of generating a \$10 win outcome, a 5% chance of generating a \$5 win outcome, a 10% chance of generating a \$2 win outcome, a 40% chance of generating a \$1 win outcome and a 44% chance of generating a \$0 loss outcome. However, when one hundred game outcomes are generated by the probability-based slot machine

10

15

20

25

30

gaming device, the actual payback may be 137% of all wagers placed and the actual generated outcomes may be six \$10 win outcomes, one \$5 win outcome, eighteen \$2 win outcomes, thirty-six \$1 win outcomes and thirty-nine \$0 loss outcomes.

5 This uncertainty is faced by players and casinos or other gaming establishments. For example, certain casinos prefer that a relatively high number of players hit low awards while a relatively low number of players hit high awards. When players hit high awards periodically, casinos attract more players, because of the positive publicity large wins generate. By using desired
10 payback percentages or probabilities, the casinos can also expect to make a certain level of profit. The random determinations can, however, unexpectedly cause casinos to suffer a loss or, on the other hand, to reap great profit in the short run and lose business in the long run due to a reputation for only paying out low awards.

15 Regulatory bodies in certain jurisdictions do not permit the use of probability-based gaming devices in-part for these reasons. These regulatory bodies permit the use of wagering gaming devices which are guaranteed to provide certain or definite awards, so that, for example, a certain number of wins is guaranteed and the overall amount paid back to players is guaranteed.
20 That is, the payback percentage is fixed and not an average expected amount. One type of gaming device which complies with this requirement is an instant-type lottery gaming device. An instant-type lottery gaming device includes a finite pool or set of electronic tickets with each electronic ticket assigned to a predetermined outcome. Alternatively, each electronic ticket could be assigned
25 to a random number or game play seed. Each seed is deterministic of a predetermined primary game outcome. That is, the gaming device utilizes the random number or game play seed in a random number sequence generator to generate random numbers that the gaming device then uses to determine and provide the predetermined primary game outcome. In an instant-type lottery
30 gaming device, as the predetermined outcome for each electronic ticket is revealed to a player on the gaming device, the ticket is removed (i.e., flagged as used) from the finite pool or set of electronic tickets. Once removed from the pool or set, a ticket cannot be used again to determine another game outcome.

This type of gaming device provides players with all of the available outcomes over the course of the play cycle and guarantees the actual wins and losses.

Since an instant-type lottery gaming device has a finite pool of predetermined win/loss outcomes, it is possible to configure the pool to specific conditions or criteria requested by the casino or gaming establishment. An
5 example of these conditions or criteria are the number of tickets included in the pool and the exact payback percentage or payback sum for the pool as a whole. The payback percentage or sum represents the guaranteed payout for the entire pool of predetermined outcomes. Other examples of conditions or criteria
10 are what prizes will be awarded and the frequency of winning outcome tickets amongst the total number of tickets for the pool. For example, if a predetermined pool includes twenty \$1 tickets and the pool has a payback sum of \$10, then the pool might consist of one \$5 win outcome, one \$2 win outcome, three \$1 win outcomes and fifteen \$0 loss outcomes and may be represented
15 as the following outcomes: 5, 2, 1, 1, 1, 0, 0, 0, 0, 0, 0, 0, 0, 0, 0, 0, 0, 0. It should be appreciated that the above described pool of twenty tickets is for illustration purposes only and a pool could include any suitable desired number of tickets including a large number such as one million or more.

Even though a pool may contain more than one of the same primary
20 game outcome (i.e., the loss or the win and if a win, the value), the presentation to the player (such as reel stops in the case of slot machines or simulated slot machines, cards dealt or drawn in the case of simulated card games and the like) is preferably varied for each sequential primary game outcome. For example, in the twenty ticket pool described above, while three primary game
25 outcomes may each determine a win primary game outcome with a value of \$1, in a slot machine type game each primary game outcome will be preferably presented to the player as multiple different or all different winning combinations of reel symbols.

Additionally, central determination gaming systems are generally known.
30 A central determination gaming system provides a plurality of individual gaming devices, located in a gaming establishment, such as a casino, coupled by one or more communication links, to a central processor or computing system. When a player plays a game on one of the gaming devices, the game outcome

is communicated from the central system to the individual gaming device and then provided to the player. It should be appreciated that one central processor may continuously run hundreds or thousands of individual gaming devices at once.

5 In order to comply with the above mentioned regulatory rules that do not permit the use of probability-based gaming devices, central determination gaming systems have been implemented wherein the central system maintains one or more predetermined pools or sets of primary game outcomes. Additionally, certain central determination gaming systems have been
10 implemented wherein the central system maintains one or more predetermined pools or sets of random number or game play seeds. The use of random number or game play seeds reduces the computational load on the central processor of the central determination gaming systems. In these systems, when a player makes a wager on one of the gaming devices, the central system
15 selects a seed used for determining the primary game outcome, marks the selected seed as used and communicates the selected seed to that individual gaming device. The individual gaming device utilizes the seed to determine the predetermined primary game outcome. Once a seed is used, it is removed (or prevented from further selection) from the predetermined pool or set and cannot
20 be selected by the central processor upon another wager.

There are a number of advantages to providing for centralized production seeds which are used for determining game outcomes at individual gaming devices. Central production or control can assist a casino or other entity in maintaining appropriate records, controlling gaming, reducing and preventing
25 cheating or electronic or other errors, reducing or eliminating win-loss volatility and the like.

Additionally, gaming devices having a primary or base game and a secondary or a bonus game are also well known. A secondary or bonus game may be any type of suitable game, either similar to or completely different from
30 the primary game, which is entered upon the occurrence of a triggering event or a selected outcome in the primary game. The secondary or bonus game enables the player to obtain a prize or payout in addition to the prize or payout, if any, obtained from the primary game. A secondary or bonus game produces

a significantly higher level of player excitement than the primary game because it provides a greater expectation of winning than the primary game and is accompanied with more attractive or unusual features than the primary game.

SUMMARY OF THE INVENTION

5 The present invention relates to a central determination gaming system wherein the same random number or game play seed is used to generate a primary or base game outcome and a secondary or bonus game outcome. The present invention includes a central computing system in communication with a plurality of gaming devices. The central computing system maintains one or
10 more predetermined pools or sets of random number or game play seeds. In one embodiment, each game play seed is deterministic of a primary wagering game outcome and a secondary game outcome. That is, each gaming device is operable to utilize a game play seed to determine both the primary wagering game outcome and the secondary game outcome.

15 In an alternative embodiment, each game play seed in a predetermined pool or set of game play seeds is deterministic of a primary wagering game outcome. Of these game play seeds, a plurality are also deterministic of a secondary game outcome. That is, each time a player initiates play at a gaming device, the gaming device enables the player to play a primary wagering game and obtain a primary wagering game outcome. A plurality of obtained primary
20 wagering game outcomes will trigger a secondary game. If a secondary game is triggered, the gaming device enables the player to play the triggered secondary game and obtain a secondary game outcome. In this embodiment, each game play seed determines a primary wagering game outcome, but only
25 the seeds that are deterministic of both a primary wagering game outcome and secondary game outcome enable a player to play and obtain outcomes in both a primary wagering game and a secondary game.

 It should be appreciated that if any one or more than one designated gaming device configured for playing a certain game receive the same specific
30 seed, the resulting random numbers generated (and thus the resulting primary and secondary game outcomes) will always be the same even though the different gaming devices operate independently from one another. That is, if a plurality of the same gaming devices each run the same game play seed

through a predefined random number generating algorithm, each of such same gaming device will generate the same series of random numbers that correspond to the same game outcomes.

In one embodiment, a player initiates play of a primary wagering game at one of the gaming devices. The primary wagering game may be a casino-type game or any other desired wagering game. The gaming device requests a game play seed from the central computing system. In response to the request for a game play seed, the central computing system randomly selects a game play seed from the predetermined pool or set of game play seeds that is maintained by the central computing system. The central computing system marks the selected seed as used (preventing it from being selected again) and outputs or communicates the selected game play seed to the gaming device. The gaming device uses the outputted game play seed to generate at least one random number. The generated random number is utilized by the gaming device to determine a primary wagering game outcome. The primary wagering game outcome is either a win outcome with an associated prize or payout that triggers a secondary game, a win outcome with an associated prize or payout that does not trigger a secondary game, a lose outcome with no associated prize or payout that does not trigger a secondary game or a secondary game qualifying condition or triggering event outcome with no associated prize or payout in the primary wagering game.

If the primary wagering game outcome is a win outcome with an associated prize or payout that does not trigger a secondary game, the player is provided the associated prize or payout and the primary wagering game terminates. If the primary wagering game outcome is a lose outcome with no associated prize or payout that does not trigger a secondary game, the player is provided no prize or payout and the primary wagering game terminates.

If the primary wagering game outcome is or includes a secondary game triggering event (i.e., either a win outcome with an associated prize or payout that triggers a secondary game win or a secondary game qualifying or triggering outcome with no associated prize or payout in the primary wagering game), the gaming device initiates a secondary or bonus game. The secondary game may be a casino-type game or any other desired wagering game. In the secondary

or bonus game, the gaming device utilizes the outputted game play seed to generate at least one secondary game or bonus random number. The generated secondary game or bonus random number is utilized by the gaming device to determine a secondary or bonus game outcome. The secondary
5 game outcome may or may not be associated with a prize or payout. If the secondary or bonus game outcome is associated with a prize or payout, the prize or payout associated with the determined secondary or bonus game outcome is provided to the player and the secondary or bonus game terminates. It should be appreciated that the same game play seed that is used to
10 determine the primary wagering game outcome is also used to determine the secondary game outcome.

In another embodiment, the secondary or bonus game outcome may be an additional secondary game qualifying condition or triggering event that initiates an additional secondary or bonus game. In this embodiment, the
15 gaming device determines the additional secondary or bonus game outcome as described above using the same outputted game play seed that is used to determine the primary wagering game outcome and the initial secondary game outcome.

The present invention provides a number of advantages over existing
20 central determination gaming systems. By utilizing the same seed to determine both the primary wagering game outcome and the secondary game outcome, the present invention requires the central computing system to maintain less game play seeds, thus reducing the computational load on the central computing system.

25 Additional features and advantages of the present invention are described in, and will be apparent from, the following Detailed Description of the Invention and the figures.

Additional features and advantages of the present invention are described in, and will be apparent from, the following Detailed Description of the
30 Invention and the figures.

BRIEF DESCRIPTION OF THE FIGURES

Figs. 1A and 1B are schematic block diagrams illustrating the central controller and the individual gaming terminals in the central determination

gaming system of the present invention.

Figs. 2A and 2B are perspective views of alternative embodiments of the gaming device of the present invention.

Fig. 3 is a schematic block diagram of an electronic configuration of one
5 embodiment of the gaming device of the present invention.

Fig. 4 is a schematic block diagram illustrating one embodiment of the present invention wherein the same game play seed is used to determine the primary wagering game outcome and the bonus game outcome.

DETAILED DESCRIPTION OF THE INVENTION

10 Referring now to the drawings, as illustrated in Fig. 1A, one embodiment of the present invention includes a plurality of gaming devices 10a, 10b and 10c located in a gaming establishment, such as a casino, coupled by one or more communication links 12a, 12b and 12c to a central computing system 14. The communication links 12 can be any of a plurality of devices known to those of
15 skill in the art for receiving data transmissions to and from the gaming device. The central computing system maintains supervision over the entire network of gaming devices.

In one embodiment, the central computing system 14 maintains at least one predetermined set or pool of predetermined game outcome seeds for each
20 type of game provided on the gaming devices. In an alternative embodiment, the central computing system maintains a plurality of predetermined sets or pools of predetermined game outcome seeds for each type of provided game. In another embodiment, the central computing system maintains a predetermined set or pool of predetermined game outcome seeds for each
25 denomination of each type of game provided on the gaming devices. Other methods for storing the pool or set of predetermined seeds may be employed in accordance with the present invention.

In one embodiment, each seed is deterministic of a primary or base game outcome and a secondary or bonus game outcome. That is, each seed is
30 utilized to determine both a primary wagering game outcome and a secondary game outcome. Thus, for any given seed, it is possible to determine the primary wagering game outcome and the secondary game outcome that will result from that seed for a particular type of game.

In an alternative embodiment, each game play seed in a predetermined pool or set of game play seeds is deterministic of a primary wagering game outcome. Of these game play seeds, a plurality are also deterministic of a secondary game outcome. That is, each time a player initiates play at a gaming device, the gaming device enables the player to play a primary wagering game and obtain a primary wagering game outcome based on a game play seed. A plurality of obtained primary wagering game outcomes are also deterministic of secondary game outcomes and will trigger a secondary game. If a secondary game is triggered, the gaming device enables the player to play the triggered secondary game and obtain a secondary game outcome based on the same game play seed. In this embodiment, each game play seed determines a primary wagering game outcome, but only the seeds that are deterministic of both a primary wagering game outcome and secondary game outcome enable a player to play and obtain outcomes in both a primary wagering game and a secondary game.

A plurality of seeds in a set or pool of predetermined game play seeds are each deterministic of the same primary game outcome (not including whether the primary wagering game outcome triggers a secondary game or not). For example, if a pay table of a game indicates six different primary wagering game outcomes (i.e., a win \$20 game outcome, a win \$10 game outcome, a win \$5 game outcome, a win \$2 game outcome, a win \$1 game outcome and lose game outcome), and the set or pool of game play seeds includes one-hundred thousand game play seeds, then a plurality of game play seeds will each be deterministic of the same primary wagering game outcome. In order to increase player entertainment, a plurality of the same primary wagering game outcomes are each presented or displayed to the player in a different way. For example, in a slot machine style gaming device, each of the same primary wagering game outcome is displayed or presented to the player as a different reel combination.

In one embodiment, all of the gaming devices which are coupled to the central computing system are configured to play the same type of game. In another embodiment, illustrated in Fig. 1B, a plurality of the gaming terminals are configured so that different gaming device or gaming terminals may be used

to play different types of games. That is, the central controller 14 may be in communication via one of more communication links 12 with a plurality of gaming devices or gaming terminals 10a that are used for playing a slot machine style game, a different plurality of gaming devices or gaming terminals 5 10b that are used for playing a poker style game, a different plurality of gaming devices or gaming terminals 10c that are used for playing a blackjack style game, and the like. In an alternative embodiment, all of the gaming terminals which are coupled to the central processor are configured to play the same type of game. In another embodiment, a plurality of gaming terminals may each be 10 configured for playing a plurality of different games. It should be appreciated that if any one or more than one designated gaming device configured for playing a certain game receive the same specific seed, the resulting random numbers generated (and thus the resulting primary and secondary game outcomes) will always be the same even though the different gaming devices 15 operate independently from one another. That is, if a plurality of gaming devices each run the same game play seed through a predefined random number generating algorithm, each gaming device will generate the same series of random numbers that correspond to the same game outcomes.

Two embodiments of the gaming device of the present invention are 20 shown in Figs. 2A and 2B as gaming device 10a and gaming device 10b, respectively. Gaming device 10a and/or gaming device 10b are generally referred to herein as gaming device 10. Gaming device 10 is in one embodiment a slot machine having the controls, displays and features of a conventional slot machine. It is constructed so that a player can operate it while 25 standing or sitting, and gaming device 10 is preferably mounted on a console. However, it should be appreciated that gaming device 10 can be constructed as a pub-style table-top game (not shown) which a player can operate preferably while sitting. Furthermore, gaming device 10 can be constructed with varying cabinet and display designs, as illustrated by the designs shown in Figs. 2A and 30 2B.

As illustrated in Figs. 2A and 2B, gaming device 10 includes a coin slot 112 and bill acceptor 114 where the player inserts money, coins or tokens. The player can place coins in the coin slot 112 or paper money in the bill acceptor

114. Other devices could be used for accepting payment such as readers or validators for credit cards or debit cards. When a player inserts money in gaming device 10, a number of credits corresponding to the amount deposited is shown in a credit display 116. After depositing the appropriate amount of money, a player can begin the game by pulling arm 118 or pushing play button 120. Play button 120 can be any play activator used by the player which starts any game or sequence of events in the gaming device.

As shown in Figs. 2A and 2B, gaming device 10 also includes a bet display 122 and a bet one button 124. The player places a bet by pushing the bet one button 124. The player can increase the bet by one credit each time the player pushes the bet one button 124. When the player pushes the bet one button 124, the number of credits shown in the credit display 116 decreases by one, and the number of credits shown in the bet display 122 increases by one.

A player may "cash out" and thereby receive a number of coins corresponding to the number of remaining credits by pushing a cash out button 126. When the player "cashes out," the player receives the coins in a coin payout tray 128. The gaming device 10 may employ other payout mechanisms such as credit slips redeemable by a cashier or electronically recordable cards which keep track of the player's credits.

Gaming device 10 also includes one or more display devices. The embodiment shown in Fig. 2A includes a central display device 130, and the alternative embodiment shown in Fig. 2B includes a central display device 130 as well as an upper display device 132. Gaming device 10 preferably displays a plurality of reels 134, preferably three to five reels 134 in mechanical or video form at one or more of the display devices. However, it should be appreciated that the display devices can display any visual representation or exhibition, including but not limited to movement of physical objects such as mechanical reels and wheels, dynamic lighting and video images. A display device can be any viewing surface such as glass, a video monitor or screen, a liquid crystal display or any other display mechanism. If the reels 134 are in video form, the display device for the video reels 134 is preferably a video monitor. It should be appreciated that the present invention can include one or more paylines displayed in a horizontal and/or diagonal fashion.

Each reel 134 displays a plurality of indicia such as bells, hearts, fruits, numbers, letters, bars or other images which preferably correspond to a theme associated with the gaming device 10. The symbols and indicia used on and in gaming device 10 may be in mechanical, electronic, electrical or video form.

5 Furthermore, gaming device 10 preferably includes speakers 136 for making sounds or playing music.

As illustrated in Fig. 3, the general electronic configuration of gaming device 10 preferably includes: a processor 138; a memory device 140 for storing program code or other data; a central display device 130; an upper
10 display device 132; a sound card 142; a plurality of speakers 136; and one or more input devices 144. The processor 138 is preferably a microprocessor or microcontroller-based platform which is capable of displaying images, symbols and other indicia such as images of people, characters, places, things and faces of cards. The memory device 140 can include random access memory (RAM)
15 146 for storing event data or other data generated or used during a particular game. The memory device 140 can also include read only memory (ROM) 148 for storing program code which controls the gaming device 10 so that it plays a particular game in accordance with applicable game rules and pay tables.

As illustrated in Fig. 3, the player preferably uses the input devices 144,
20 such as pull arm 118, play button 120, the bet one button 124 and the cash out button 126 to input signals into gaming device 10. In certain instances it is preferable to use a touch screen 150 and an associated touch screen controller 152 instead of a conventional video monitor display device. Touch screen 150 and touch screen controller 152 are connected to a video controller 154 and
25 processor 138. A player can make decisions and input signals into the gaming device 10 by touching touch screen 150 at the appropriate places. As further illustrated in Fig. 3, the processor 138 can be connected to coin slot 112 or bill acceptor 114. The processor 138 can be programmed to require a player to deposit a certain amount of money in order to start the game.

30 It should be appreciated that although a processor 138 and memory device 140 are preferable implementations of the present invention, the present invention can also be implemented using one or more application-specific integrated circuits (ASIC's) or other hard-wired devices, or using mechanical

devices (collectively and/or alternatively referred to herein as a "processor"). Furthermore, although the processor 138 and memory device 140 preferably reside on each gaming device 10 unit, it is possible to provide some or all of their functions at a central location such as a network server for communication
5 to a playing station such as over a local area network (LAN), wide area network (WAN), Internet connection, microwave link, and the like.

With reference to Fig. 4, in one embodiment illustrating a slot machine style gaming device, to initiate operation of the gaming device the player must insert the appropriate amount of money or tokens and then pull the arm or push
10 the play button as indicated in block 202. The reels will then begin to spin. As the wheels are spinning, the gaming device requests a game play seed from the central computing system of the central determination gaming system. In an alternative embodiment, the gaming device request a game play seed from the central computing system upon the player placing a wager in the gaming
15 device.

Upon receiving a request for a game play seed, the central computing system selects a game play seed from the predetermined set or pool of predetermined game play seeds for the specific type of game played. The selected game play seed is communicated or outputted to the requesting
20 gaming device as indicated in block 204. Once communicated or outputted to the requesting gaming device, the game play seed is marked or removed from the pool or set of predetermined seeds for the particular game played. Once a seed is marked or removed, it cannot be selected by the central computing system upon another wager. Other methods of sending a game play seed to
25 the requesting individual gaming device may be employed in accordance with the present invention.

The processor of the gaming device uses the received game play seed in a random number generating algorithm to generate at least one random number as indicated in block 206. The generated random number is used to determine
30 the primary game outcome as indicated in block 208. In one embodiment, the generated random number or a portion of the generated random number (i.e., the first four numbers after a decimal spot) is associated with a primary wagering game outcome. In this embodiment, the gaming device determines

the primary wagering game outcome associated with the generated random number. In this embodiment, the processor of the gaming device proceeds to utilize at least one of the generated random numbers to determine a presentation of the determined primary wagering game outcome. That is, using
5 at least one of the generated random numbers, the processor will determine how the determined primary wagering game outcome is displayed or presented to the player (i.e., for a slot machine gaming device, the specific reel combination that corresponds to the determined primary wagering game outcome).

10 In another embodiment, the processor of the gaming device generates a plurality of random numbers based on the received game play seed and uses a plurality of the generated random numbers to determine a primary wagering game outcome. For example, in a 3-reel slot machine style game, the processor may generate three random numbers. The first random number is
15 used by the processor of the gaming device to determine the stop position of the first reel. The second random number is used by the processor to determine the stop position of the second reel. The third random number is used by the processor to determine the stop position of the third reel. The processor then compares the stopped reel combination to a pay table or other
20 stored data to determine the primary wagering game outcome.

The primary wagering game outcome is either a win outcome with an associated prize or payout that triggers a secondary game, a win outcome with an associated prize or payout that does not trigger a secondary game, a lose
25 outcome with no associated prize or payout that does not trigger a secondary game or a secondary game qualifying or triggering outcome that does trigger a secondary game with no associated primary wagering game prize or payout.

The processor of the gaming device determines if the primary wagering game outcome contains a secondary game qualifying condition or triggering event as indicated in diamond 210. If the primary wagering game outcome is a
30 win outcome with an associated prize or payout that does not trigger a secondary game, the player is provided the associated prize or payout as indicated in block 212 and the primary wagering game terminates as indicated in block 214. If the primary wagering game outcome is a lose outcome with no

associated prize or payout that does not trigger a secondary game, the player is provided no prize or payout and the primary wagering game terminates as indicated in block 214.

5 If the primary wagering game outcome contains a secondary game triggering event or qualifying condition (i.e., a win outcome with an associated prize or payout that triggers a secondary game or a secondary game qualifying condition or triggering event with no associated primary wagering game prize or payout), the gaming device initiates a secondary or bonus round as indicated in block 216. The secondary game qualifying condition or triggering event can be a
10 particular arrangement of indicia on the reels or display device. The gaming device preferably uses a video-based central display device to enable the player to play the secondary or bonus round. In one embodiment, a plurality of different gaming devices that are coupled to the central computing system each provide a different secondary or bonus game. In another embodiment, each
15 gaming device provides a plurality of different secondary or bonus games. In one embodiment, the secondary or bonus game is the same game as the primary or base game. In another embodiment, the secondary or bonus game is a different game than the primary or base game.

In the secondary or bonus game, the individual gaming device utilizes the
20 same received game play seed to generate at least one secondary game or bonus random number as indicated in block 218. In an alternative embodiment, the gaming device utilizes the same received game play seed to generate a plurality of secondary game or bonus random numbers. In another embodiment, the gaming device does not generate additional seeds, but uses at
25 least one or a plurality of the plurality of random number seeds that were generated to determine the primary wagering game outcome. It should be appreciated that if the processor of the gaming device initiates the play of a secondary or bonus game, the processor utilizes the same received game play seed to determine both the primary wagering game outcome and the secondary
30 or bonus game outcome.

The gaming device uses the generated secondary game or bonus random number to determine the secondary or bonus game outcome as indicated in block 220 and as described above regarding the processor

determining the primary wagering game outcome. In one embodiment, the secondary or bonus game outcome is a bonus or secondary game win outcome with an associated bonus prize or payout. In another embodiment, the secondary or bonus game outcome is either a secondary or bonus game win outcome with an associated bonus prize or payout or a secondary or bonus game lose outcome with no associated bonus prize or payout. The determined secondary or bonus game outcome, is provided to the player as indicated in block 222 and the game terminates as indicated in block 214. It should be appreciated that the processor of the gaming device may proceed to utilize at least one of the generated random numbers to determine a presentation of the determined secondary game outcome. That is, using at least one of the generated random numbers, the processor will determine how the determined secondary game outcome is displayed or presented to the player.

In an alternative embodiment, the secondary or bonus game outcome is an additional secondary or bonus game qualifying condition or triggering event. In this embodiment, the gaming device initiates an additional secondary or bonus game. It should be appreciated that the gaming device utilizes the same received game play seed that determined the primary wagering game outcome and the initial secondary game outcome to determine the additional secondary or bonus game outcome as described above.

It should be appreciated that regardless of how the game outcome is ultimately presented to the player, either as a prize or payout from the primary or base game, as a prize or payout from the secondary or bonus game, as a lose from the primary or base game or as a lose from the secondary or bonus game, the game outcome is predetermined. For example, if a particular game play seed in a \$1 slot machine gaming device is deterministic of an outcome with an associated prize or payout of \$10, the outcome may be presented to the player as a \$10 win outcome in the primary or base game, a \$10 secondary or bonus game win outcome or any combination of payouts in the primary or base game and secondary or bonus game that result in a total payout of \$10. Either way, the player is provided \$10 and that particular game play seed is removed from the set of seeds.

It should be understood that various changes and modifications to the presently preferred embodiments described herein will be apparent to those skilled in the art. Such changes and modifications can be made without departing from the spirit and scope of the present invention and without
5 diminishing its intended advantages. It is therefore intended that such changes and modifications be covered by the appended claims.

It should be understood that various changes and modifications to the presently preferred embodiments described herein will be apparent to those skilled in the art. Such changes and modifications can be made without
10 departing from the spirit and scope of the present invention and without diminishing its intended advantages. It is therefore intended that such changes and modifications be covered by the appended claims.

CLAIMS

The invention is claimed as follows:

1. A central determination gaming system comprising:
5 a seed set, wherein said seed set includes a plurality of predetermined game play seeds; and
a central computer operable to store said seed set, to randomly select a game play seed from said seed set, to prevent said selected game play seed in said seed set from further selection from said seed set, and to output said
10 selected game play seed to at least one gaming device in communication with said central computer, wherein said gaming device includes a processor operable to enable a player to initiate a primary wagering game, to receive said outputted game play seed, to determine a primary wagering game outcome based on said outputted game play seed, to determine a secondary game
15 outcome based on said outputted game play seed and to provide said determined game outcomes to the player.
2. The central determination gaming system of Claim 1, which includes a plurality of seed sets.
20
3. The central determination gaming system of Claim 1, wherein a plurality of gaming devices are in communication with said central computer.
4. The central determination gaming system of Claim 3, wherein said
25 primary wagering game of at least two of said plurality of gaming devices are different.
5. The central determination gaming system of Claim 1, wherein said central computer outputs a game play seed in response to a request for a game
30 play seed from said gaming device.
6. The central determination gaming system of Claim 1, wherein each game play seed is deterministic of a primary wagering game outcome.

7. The central determination gaming system of Claim 6, wherein a plurality of game play seeds are deterministic of a secondary game outcome.

8. The central determination gaming system of Claim 1, wherein
5 each game play seed is deterministic of both a primary wagering game outcome and a secondary game outcome.

9. The central determination gaming system of Claim 1, wherein the
10 processor of the gaming device is operable to generate a plurality of random numbers based on said outputted game play seed.

10. The central determination gaming system of Claim 9, wherein the
processor of the gaming device is operable to determine said primary wagering
game outcome based on at least one of said generated random numbers.

15

11. The central determination gaming system of Claim 10, wherein the
processor of the gaming device is operable to determine a presentation of said
determined primary wagering game outcome based on at least one of said
generated random numbers.

20

12. The central determination gaming system of Claim 9, wherein the
processor of the gaming device is operable to determine said secondary game
outcome based on at least one of said generated random numbers.

25 13. The central determination gaming system of Claim 12, wherein the
processor of the gaming device is operable to determine a presentation of said
determined secondary game outcome based on at least one of said generated
random numbers.

30 14. A central determination gaming system comprising:
a set of game play seeds, wherein said set includes a plurality of
predetermined game play seeds and a plurality of said game play seeds are
deterministic of a primary wagering game outcome and a secondary game

outcome; and

a central computer operable to randomly select a game play seed from said set of game play seeds, to prevent said selected game play seed from further selection from said set of game play seeds and to communicate said
5 selected game play seed to at least one gaming device, wherein said gaming device includes a processor operable to enable a player to initiate a primary wagering game, to receive said selected game play seed, to determine a primary wagering game outcome for said primary wagering game based on said
10 selected game play seed, to initiate at least one secondary game if said determined primary wagering game outcome contains a secondary game triggering event, to determine a secondary game outcome based on said selected game play seed and to provide the player said determined game outcomes.

15 15. The central determination gaming system of Claim 14, wherein the processor of the gaming device is operable to initiate a plurality of secondary games if said determined primary wagering game outcome contains a secondary game triggering event.

20 16. The central determination gaming system of Claim 14, wherein the processor of the gaming device is operable to initiate at least one additional secondary game if said determined secondary game outcome contains a secondary game triggering event.

25 17. A gaming device comprising:
a primary wagering game operable upon a wager by a player;
a display device; and
a processor in communication with said display device operable to enable the player to initiate the primary wagering game, to receive a game play
30 seed from a central computing system, to determine a primary wagering game outcome for said primary wagering game based on said received game play seed, to determine a secondary game outcome based on said received game play seed and to provide said determined game outcomes to the player.

18. The gaming device of Claim 17, wherein each game play seed is deterministic of a primary wagering game outcome.

19. The gaming device of Claim 18, wherein a plurality of received
5 game play seeds are deterministic of a secondary game outcome.

20. The gaming device of Claim 17, wherein each received game play seed is deterministic of both a primary wagering game outcome and a secondary game outcome.

10

21. A gaming device comprising:

a primary wagering game operable upon a wager by a player

a display device; and

a processor in communication with said display device operable to
15 enable the player to initiate a primary wagering game, to receive a game play seed from central computing system, to determine a primary wagering game outcome based on said received game play seed, to initiate at least one secondary game if said determined primary wagering game outcome contains a secondary game triggering event, to determine a secondary game outcome
20 based on said received game play seed and to provide the player said determined game outcomes.

22. The gaming device of Claim 21, wherein each game play seed is deterministic of a primary wagering game outcome.

25

23. The gaming device of Claim 22, wherein a plurality of received game play seeds are deterministic of a secondary game outcome.

24. The gaming device of Claim 21, wherein each received game play
30 seed is deterministic of both a primary wagering game outcome and a secondary game outcome.

25. A gaming device comprising:
a primary wagering game operable upon a wager by a player;
a display device; and
a processor in communication with said display device operable to
5 enable the player to initiate the primary wagering game, to receive a game play
seed from a central computing system, to generate a plurality of random
numbers based on said received game play seed, to determine a primary
wagering game outcome for said primary wagering game based on at least one
of said generated random numbers, to determine a secondary game outcome
10 based on at least one of said generated random numbers and to provide said
determined game outcomes to the player.

26. The gaming device of Claim 25, wherein the processor is operable
to determine said primary wagering game outcome for said primary wagering
15 game based on a plurality of said generated random numbers.

27. The gaming device of Claim 25, wherein the processor is operable
to determine said secondary game outcome based on a plurality of said
generated random numbers.

20

28. The gaming device of Claim 25, wherein the processor is operable
to determine a presentation of said determined primary wagering game
outcome based on at least one of said generated random numbers.

25 29. The gaming device of Claim 25, wherein the processor is operable
to determine a presentation of said determined primary wagering game
outcome based on a plurality of said generated random numbers.

30 30. The gaming device of Claim 25, wherein the processor is operable
to determine a presentation of said determined secondary game outcome based
on at least one of said generated random numbers.

31. The gaming device of Claim 25, wherein the processor is operable to determine a presentation of said determined secondary game outcome based on a plurality of said generated random numbers.

5 32. A method for operating a gaming device, said method comprising the steps of:

- (a) enabling a player to initiate a primary wagering game;
- (b) receiving a game play seed from a central computing system;
- (c) determining a primary wagering game outcome based on said
10 received game play seed;
- (d) providing said primary wagering game outcome, if any, to said player;
- (e) determining a secondary game outcome based on said received game play seed, if said primary wagering game outcome is a secondary game triggering event;
- 15 (f) providing said secondary game outcome, if any, to the player; and
- (g) terminating said operation of said gaming device.

33. A method for operating a gaming device, said method comprising the steps of:

- 20 (a) enabling a player to initiate a primary wagering game;
- (b) receiving a game play seed from a central computing system;
- (c) calculating a plurality of random numbers based on said received game play seed;
- (d) determining a primary wagering game outcome based on at least one
25 of said calculated random numbers;
- (e) providing said primary wagering game outcome, if any, to said player;
- (f) determining a secondary game outcome based on at least one of said calculated random number, if said primary wagering game outcome is a secondary game triggering event;
- 30 (g) providing said secondary game outcome, if any, to the player; and
- (h) terminating said operation of said gaming device.

FIG. 1A

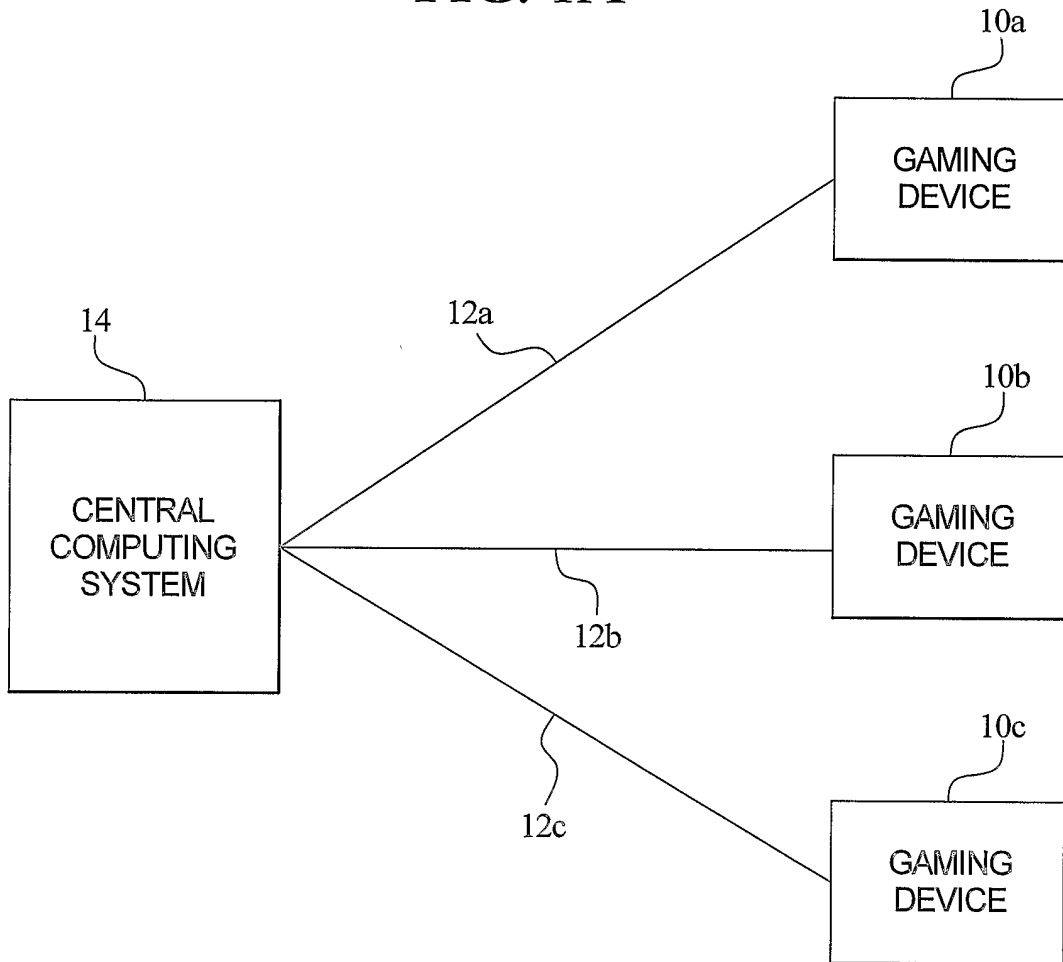

FIG. 1B

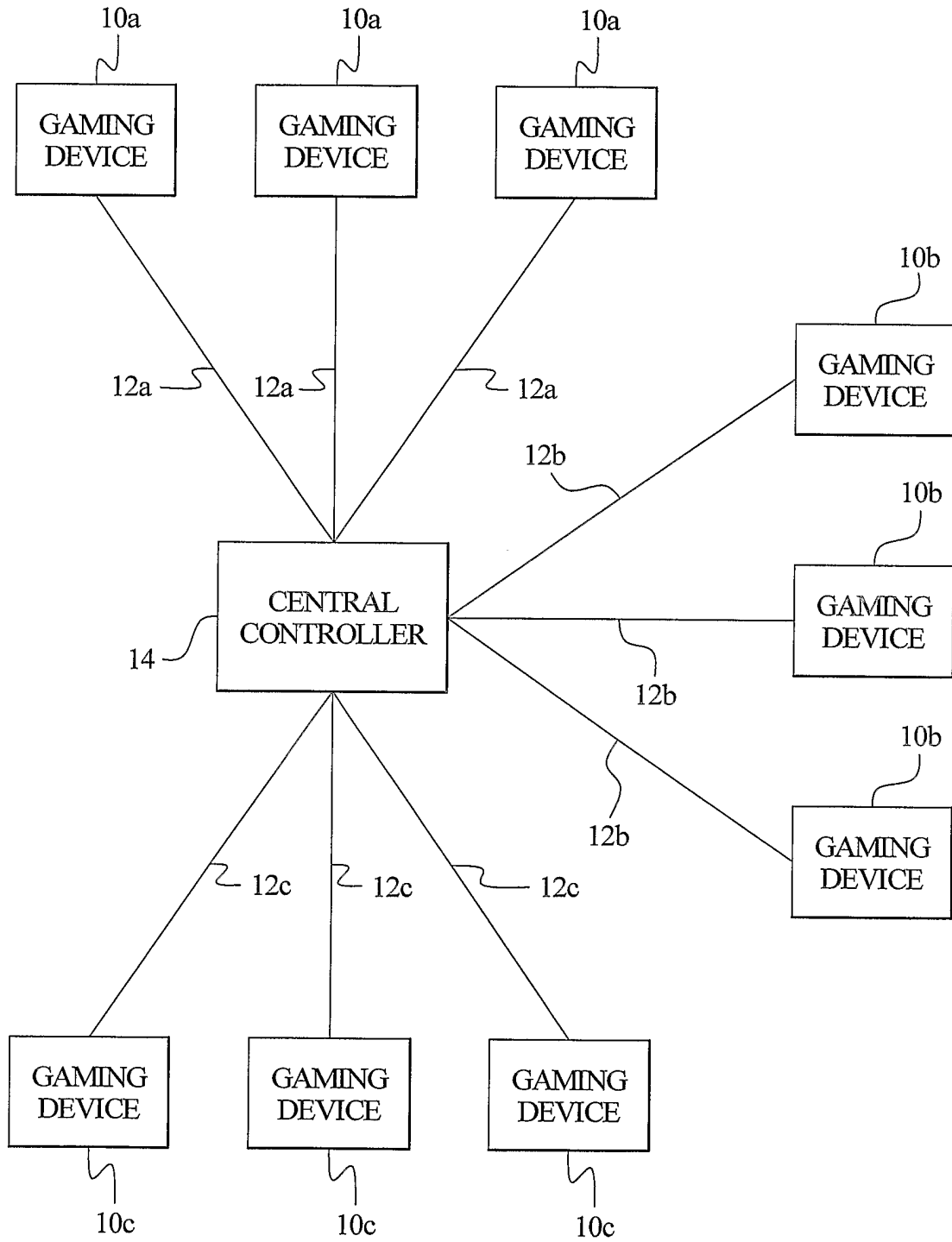

FIG. 2A

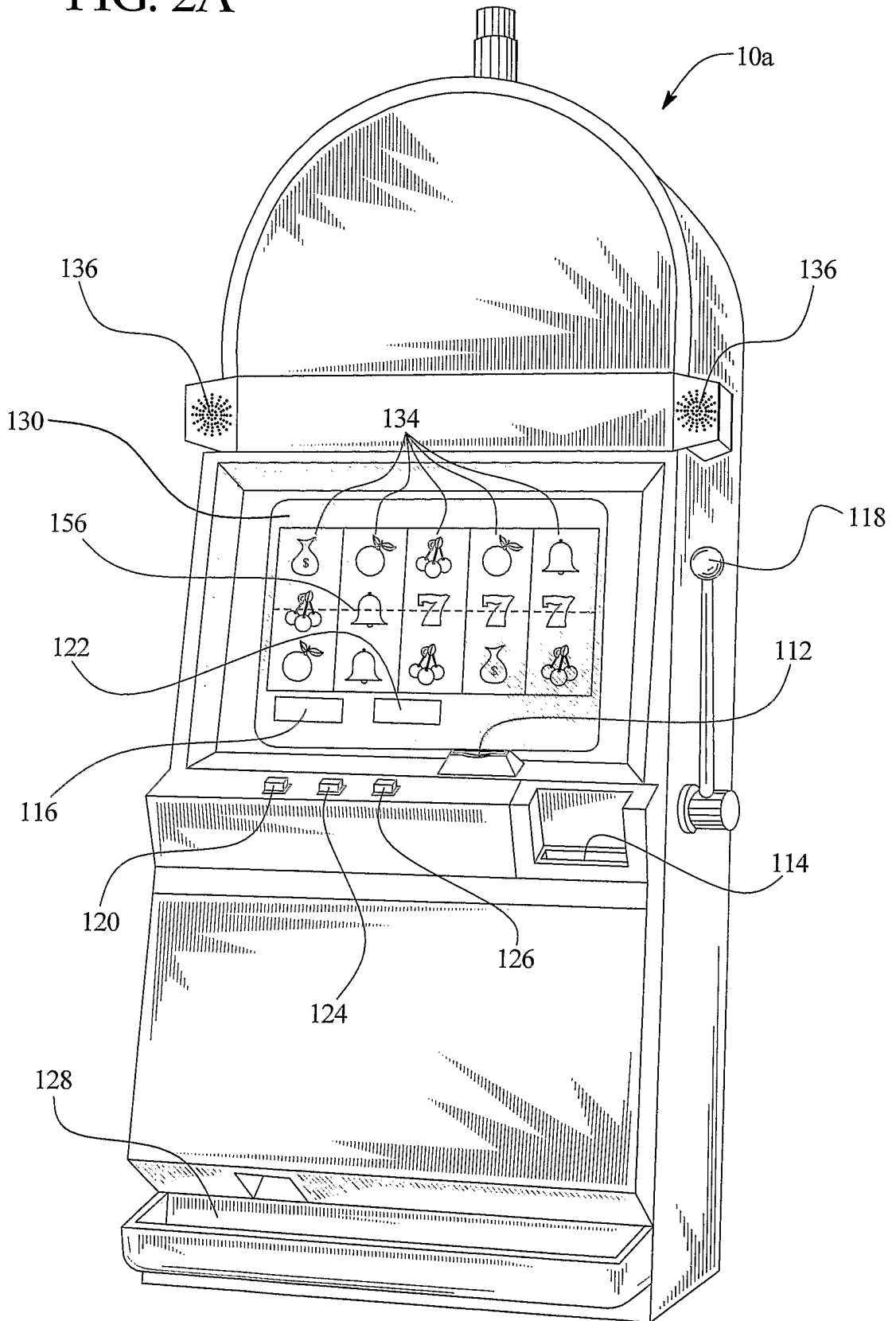

FIG. 2B

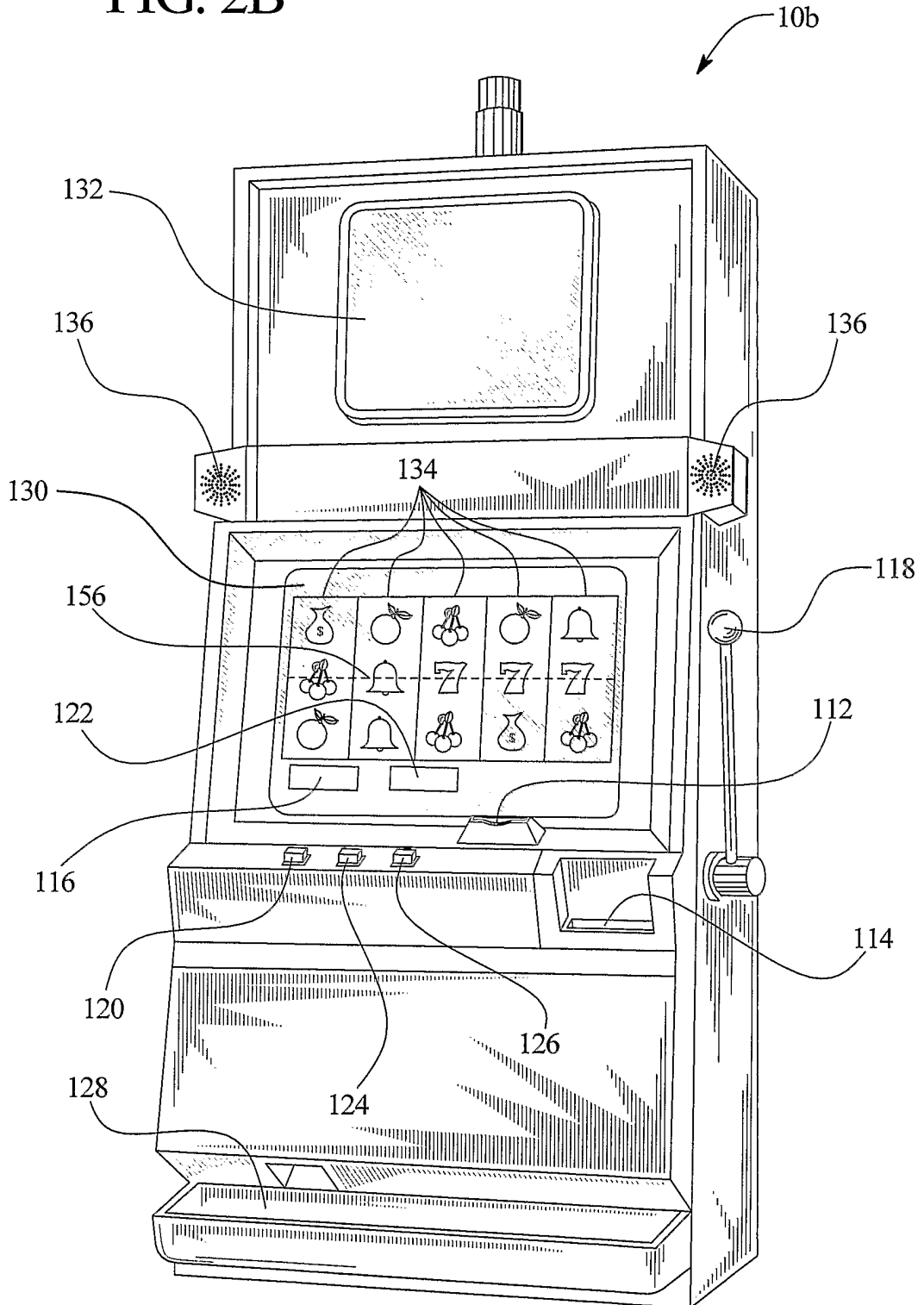

FIG. 3

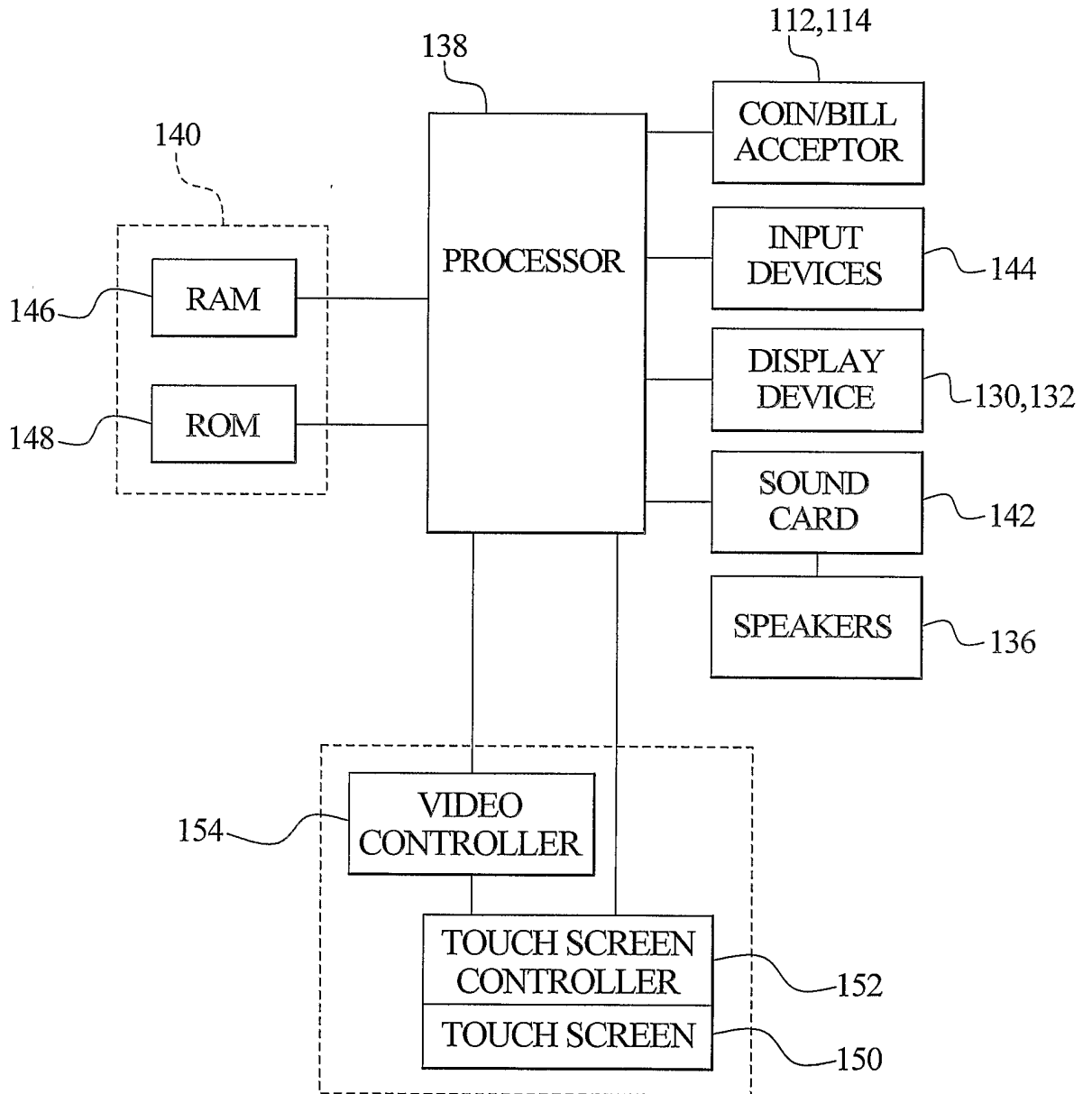

FIG. 4

