

(12) PATENT
(19) AUSTRALIAN PATENT OFFICE

(11) Application No. AU 199962083 B2
(10) Patent No. 758201

(54) Title
Reinforced impact-embrittled braking device

(51)⁶ International Patent Classification(s)
B60T 013/567 B60T 013/565

(21) Application No: 199962083 (22) Application Date: 1999 . 10 . 18

(87) WIPO No: WO00/23307

(30) Priority Data

(31) Number	(32) Date	(33) Country
98/13187	1998 . 10 . 20	FR

(43) Publication Date : 2000 . 05 . 08
(43) Publication Journal Date : 2000 . 06 . 29
(44) Accepted Journal Date : 2003 . 03 . 20

(71) Applicant(s)
Bosch Systemes De Freinage

(72) Inventor(s)
Cedric Leboisne

(74) Agent/Attorney
BALDWIN SHELSTON WATERS,Level 21,60 Margaret Street,SYDNEY NSW
2000

(56) Related Art
DE 4202820
DE 19524503

ABSTRACT

TITLE : STRENGTHENED BRAKING DEVICE WEAKENED
UNDER IMPACT

INVENTOR : MR C. LEBOISNE

APPLICANT : BOSCH SYSTEMES DE FREINAGE

The invention relates to a braking device comprising a master cylinder secured, by means of a flange (21) and of a nut (3) to the through-bolt 13 of a pneumatic booster, the through-bolt (13) having a threaded front end (131) and a shoulder (132) holding the front wall (111) of the booster in position.

According to the invention, the nut (3) has a barrel (31) engaged in a hole (211) in the flange (21) of the master cylinder and screwed onto the front end (131) of the through-bolt (13), and a collar (32) pressing the flange (21) against the front shell (111), the barrel (31) of the nut and the shoulder (132) of the through-bolt having first and second respective sections (S1, S2) facing one another, the first (S1) of which completely covers the second (S2).

Figure 2.



62083/99

PCT

ORGANISATION MONDIALE DE LA PROPRIÉTÉ INTELLECTUELLE
Bureau international

DEMANDE INTERNATIONALE PUBLIÉE EN VERTU DU TRAITE DE COOPERATION EN MATIÈRE DE BREVETS (PCT)

(51) Classification internationale des brevets ⁷ : B60T 13/567, 13/565	A1	(11) Numéro de publication internationale: WO 00/23307 (43) Date de publication internationale: 27 avril 2000 (27.04.00)
<p>(21) Numéro de la demande internationale: PCT/FR99/02535</p> <p>(22) Date de dépôt international: 18 octobre 1999 (18.10.99)</p> <p>(30) Données relatives à la priorité: 98/13187 20 octobre 1998 (20.10.98) FR</p> <p>(71) Déposant (pour tous les Etats désignés sauf US): BOSCH SYSTEMES DE FREINAGE [FR/FR]; 126, rue de Stalingrad, F-93700 Drancy (FR).</p> <p>(72) Inventeur; et (75) Inventeur/Déposant (US seulement): LEBOISNE, Cédric [FR/FR]; 44bis, rue de Montreuil, F-75011 Paris (FR).</p> <p>(74) Mandataire: HOUPLAIN, Jacques; Bosch Systèmes de Freinage, Service Brevets, 126, rue de Stalingrad, F-93700 Drancy (FR).</p>	<p>(81) Etats désignés: AU, JP, US, brevet européen (AT, BE, CH, CY, DE, DK, ES, FI, FR, GB, GR, IE, IT, LU, MC, NL, PT, SE).</p> <p>Publiée Avec rapport de recherche internationale. Avant l'expiration du délai prévu pour la modification des revendications, sera republiée si des modifications sont reçues.</p>	
(54) Title: REINFORCED IMPACT-EMBRITTLED BRAKING DEVICE		
(54) Titre: DISPOSITIF DE FREINAGE RENFORCE FRAGILISE AU CHOC		
(57) Abstract		
<p>The invention concerns a braking device comprising a master cylinder fixed by means of a flange (21) and a bolt (3), on the pull rod (13) of a brake booster, the pull rod (13) having a threaded front end (131) and a shoulder (132) maintaining the brake booster front wall (111). The invention is characterised in that the bolt (3) has a shank (31) engaged in an orifice (121) of the master cylinder flange (21) and screwed on the front end (131) of the pull rod (13), and a flange ring (32) pressing the flange (21) against the front shell (111), the shank (31) of the bolt and the shoulder (132) of the pull rod having respective first and second sections (S1, S2) opposite each other, whereof the first (S1) entirely covers the second (S2).</p>		
(57) Abrégé		
<p>L'invention concerne un dispositif de freinage comprenant un maître-cylindre fixé, au moyen d'une bride (21) et d'un écrou (3), sur le tirant (13) d'un servomoteur pneumatique d'assistance, le tirant (13) présentant une extrémité avant (131) filetée et un épaulement (132) maintenant la paroi avant (111) du servomoteur. Selon l'invention, l'écrou (3) présente un fût (31) engagé dans un orifice (211) de la bride (21) du maître-cylindre et vissé sur l'extrémité avant (131) du tirant (13), et une collerette (32) appuyant la bride (21) contre la coquille avant (111), le fût (31) de l'écrou et l'épaulement (132) du tirant ayant des première et seconde sections (S1, S2) respectives en regard l'une de l'autre, dont la première (S1) recouvre intégralement la seconde (S2).</p>		

STRENGTHENED BRAKING DEVICE WEAKENED UNDER IMPACT

The present invention relates to a braking device for a vehicle, comprising a pneumatic booster, a master cylinder and a securing nut, the booster comprising in particular a rigid casing, a moving partition and a through-bolt, the casing comprising a
5 front shell and a rear shell forming respective walls for a front chamber and a rear chamber which are defined inside the casing and separated from one another by the moving partition, the through-bolt passing through the front shell and rear shell in an axial direction in order to join these together, and having a threaded front end outside the front chamber and a shoulder on which the front shell rests inside the front chamber, the
10 master cylinder comprising a flange pierced with a hole through which the front end of the through-bolt passes.

Boosters of this type are known in the prior art, and an example of one is given in patent document DE-2,830,262.

Any discussion of the prior art throughout the specification should in no way be
15 considered as an admission that such prior art is widely known or forms part of common general knowledge in the field.

SUMMARY OF THE INVENTION

According to a first aspect of the invention there is provided a braking device for a vehicle, comprising a pneumatic booster, a master cylinder and a securing nut, the
20 booster comprising in particular a rigid casing, a moving partition and a through-bolt, the casing comprising a front shell and a rear shell forming respective walls for a front chamber and a rear chamber which are defined inside the casing and separated from one another by the moving partition, the through-bolt passing through the front shell and rear shell in an axial direction in order to join these together, and having a threaded front end
25 outside the front chamber and a shoulder on which the front shell rests inside the front chamber, the master cylinder comprising a flange pierced with a hole through which the front end of the through-bolt passes, wherein the securing nut has a barrel engaged in the hole in the flange and screwed onto the front end of the through-bolt, and a collar



pressing the flange against the front shell, in that the front shell is trapped between the barrel and the shoulder of the through-bolt, in that the barrel of the nut and in that the shoulder of the through-bolt have first and second respective sections (S1, S2) facing one another, and in that the first section (S1) completely covers the second section (S2).

5 Unless the context clearly requires otherwise, throughout the description and the claims, the words 'comprise', 'comprising', and the like are to be construed in an inclusive sense as opposed to an exclusive or exhaustive sense; that is to say, in the sense of "including, but not limited to".

10 The presented invention rests on the discovery that boosters with through-bolts, although displaying the advantage of exhibiting a very satisfactory overall rigidity for a relatively small casing thickness, also have the drawback of being able to transmit very high forces towards the driver in the event of an accidental frontal impact on the vehicle.

Advantageously, the invention precisely avoids the transmitting to the driver forces of impact received by a braking device employing a booster with through-bolts.

15 To this end, the device of the invention, which in other respects is in accordance with the above preamble, wherein the securing nut has a barrel engaged in the hole in the flange and screwed onto the front end of the through-bolt, and a collar pressing the flange against the front shell, in that the barrel of the nut and the shoulder of the through-bolt have the first and second respective sections facing one another, and in that the first
20 section completely covers the second section.

By virtue of this arrangement, a frontal impact received by the master cylinder is absorbed by crumpling of the front shell, instead of being transmitted to the bulkhead by the through-bolt, as was the case in the prior art.

25 The through-bolt may also be of tubular shape, it being possible for the front shell itself to be crimped to the shoulder of this through-bolt.



DESCRIPTION OF THE DRAWINGS

A preferred embodiment of the invention will now be described, by way of example only, with reference to the accompanying drawings in which:

- Figure 1 is a view in part section of a known braking device employing a booster with through-bolts;

- Figure 2 is a sectioned view of the structural details of a braking device in accordance with the invention, corresponding to a first embodiment, and observed prior to an impact;

- Figure 3 is a sectioned view of the structural details of a braking device in accordance with the invention, corresponding to a first embodiment, and observed after an impact;

- Figure 4 is a sectioned view of the structural details of a braking device in accordance with the invention, corresponding to a second embodiment, and observed prior to an impact; and,

- Figure 5 is a sectioned view of the structural details of a braking device in accordance with the invention, corresponding to a second embodiment, and observed after an impact.

DETAILED DESCRIPTION OF THE PREFERRED EMBODIMENTS

As seen in Figure 1, the invention relates in general to a braking device for a vehicle, essentially comprising a pneumatic booster 1, a master cylinder 2 and a securing nut 3.

The booster 1 itself comprises in particular a rigid casing 11, a moving partition 12 and a through-bolt such as 13.



In actual fact, a booster with through-bolts generally comprises several through-bolts such as 13 and 13', analogous to the through-bolt 13, and which will, together with their surroundings, be implicitly
5 described at the same time as the through-bolt 13 and its surroundings.

The casing 11 is made up of a front shell 111 and of a rear shell 112, which form respective walls for a front chamber 41 and a rear chamber 42 which are
10 defined inside the casing 11 and separated from one another by the moving partition 12.

The through-bolt 13 passes through the front shell 111 and rear shell 112 in an axial direction X to join these to one another, and may consist either of a
15 solid screw as shown in Figure 1, or of a tube through which a screw 14 passes, as shown in Figures 2 to 5.

In either case, the through-bolt 13 has a threaded front end 131 outside the front chamber 41, and shoulder 132 against which the front shell 111
20 rests inside the front chamber 41.

The master cylinder 2 has a securing flange 21 pierced with a hole 211 through which the front end 131 of the through-bolt 13 passes.

The securing nut 3 has, on the one hand, a
25 barrel 31 engaged in the hole 211 in the flange and screwed onto the front end 131 of the through-bolt 13 and, on the other hand, a collar 32 able to press the flange 21 against the front shell 111, the barrel 31 of the nut 3 and the shoulder 132 of the through-bolt 13
30 having first and second respective sections S1, S2 facing one another.

According to the invention, the section S1 of the barrel 31 of the nut 3 completely covers the section S2 of the shoulder 132 of the through-bolt 13.

35 Figures 2 and 3 illustrate the benefit of the invention in a first embodiment, in which the front shell 111 is trapped between the barrel 31 of the nut 3 and the shoulder 132 of the through-bolt 13.



In this case, a frontal impact on the master cylinder 2 has the effect of shearing the sheet metal of which the front shell 111 is formed, so that the master cylinder 2 can penetrate the front chamber 41
5 without encountering the through-bolt 13, thus avoiding transmitting an intense axial force to it, which, by contrast, was what occurred in the prior art.

The benefit of the invention is also illustrated by Figures 4 and 5 in the case of a second
10 embodiment in which the front shell 111 is crimped onto the shoulder 132 of the through-bolt 13.

In these conditions, a frontal impact on the master cylinder 2 has the effect of uncrimping from the shoulder 132 the sheet metal of which the front shell
15 111 is formed, the master cylinder 2, in this case also, being able to penetrate the front chamber 41 without interfering with the through-bolt 13.



THE CLAIMS DEFINING THE INVENTION ARE AS FOLLOWS:-

1. A braking device for a vehicle, comprising a pneumatic booster, a master cylinder and a securing nut, the booster comprising in particular a rigid casing, a moving partition and a through-bolt, the casing comprising a front shell and a rear shell forming
5 respective walls for a front chamber and a rear chamber which are defined inside the casing and separated from one another by the moving partition, the through-bolt passing through the front shell and rear shell in an axial direction in order to join these together, and having a threaded front end outside the front chamber and a shoulder on which the front shell rests inside the front chamber, the master cylinder comprising a flange pierced
10 with a hole through which the front end of the through-bolt passes, wherein the securing nut has a barrel engaged in the hole in the flange and screwed onto the front end of the through-bolt, and a collar pressing the flange against the front shell, in that the front shell is trapped between the barrel and the shoulder of the through-bolt, in that the barrel of the nut and in that the shoulder of the through-bolt have first and second respective
15 sections (S1, S2) facing one another, and in that the first section (S1) completely covers the second section (S2).
2. A braking device according to Claim 1, wherein the through-bolt is of tubular shape.
3. A braking device according to Claim 2, wherein the front shell is crimped to the
20 shoulder of the through-bolt.
4. A braking device for a vehicle substantially as herein described with reference to any one of the embodiments of the invention illustrated in the accompanying drawings and/or examples.

Dated this 20th Day of December

25 BOSCH SYSTEMES DE FREINAGE

Attorney: KENNETH W. BOLTON

Fellow Institute of Patent and Trade Mark Attorneys of Australia

of BALDWIN SHELSTON WATERS



1/2

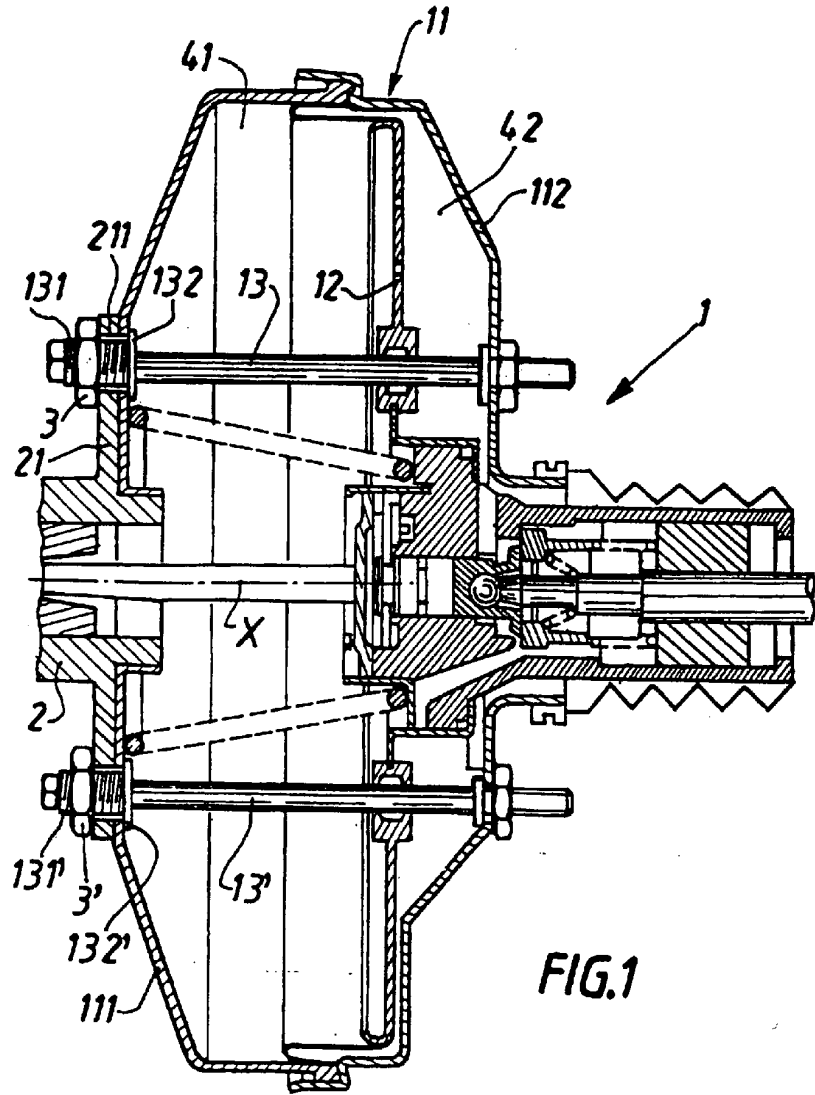

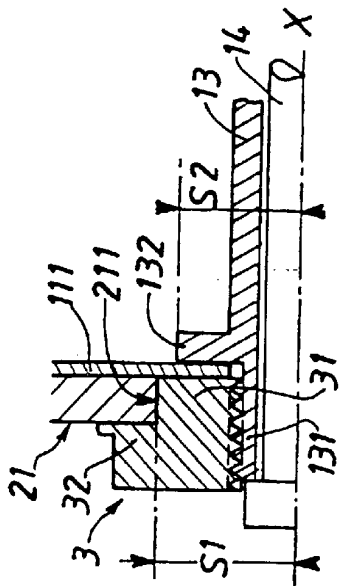

FIG. 2

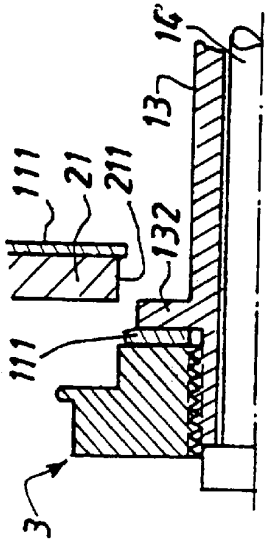

FIG. 3

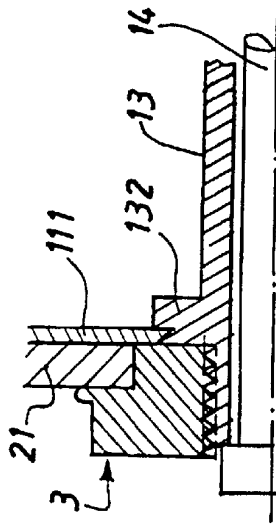

FIG. 4

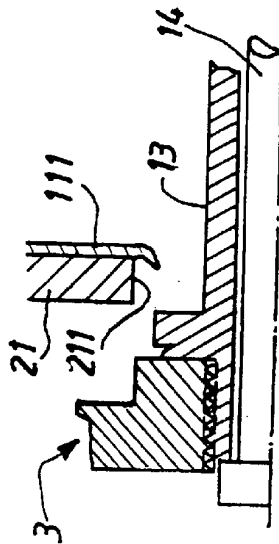

FIG. 5