

Oct. 30, 1934.

E. J. SVENSON
PUMPING MECHANISM

1,978,480

Filed June 20, 1930

2 Sheets-Sheet 1

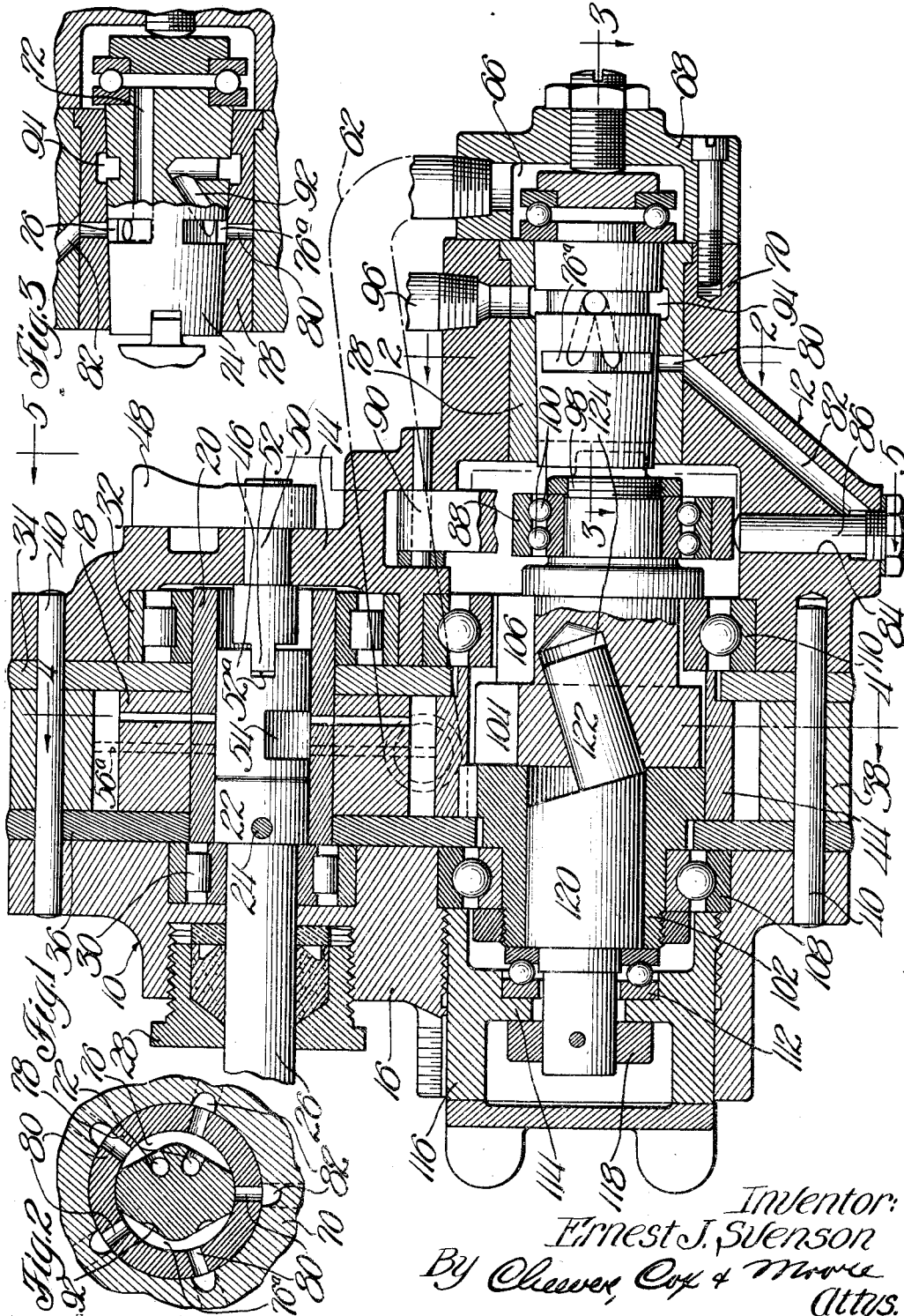

Inventor:
Ernest J. Svenson
By Cleaver, Cox & Moore
Attys.

Oct. 30, 1934.

E. J. SVENSON

1,978,480

PUMPING MECHANISM

Filed June 20, 1930

2 Sheets-Sheet 2

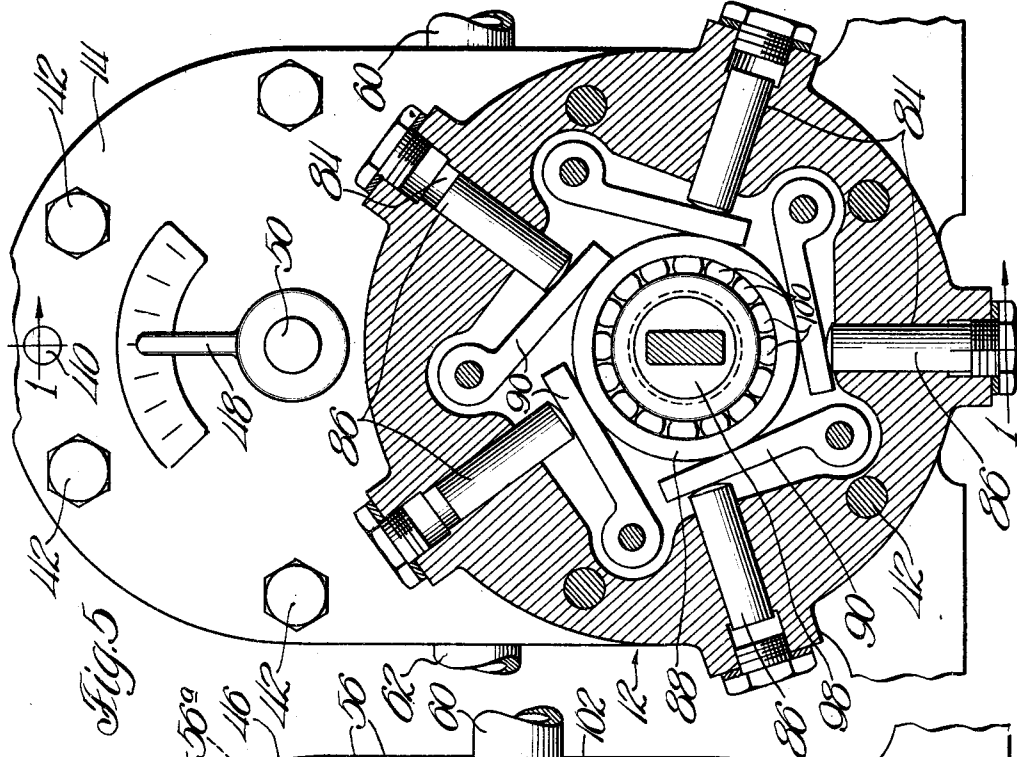

Fig. 5

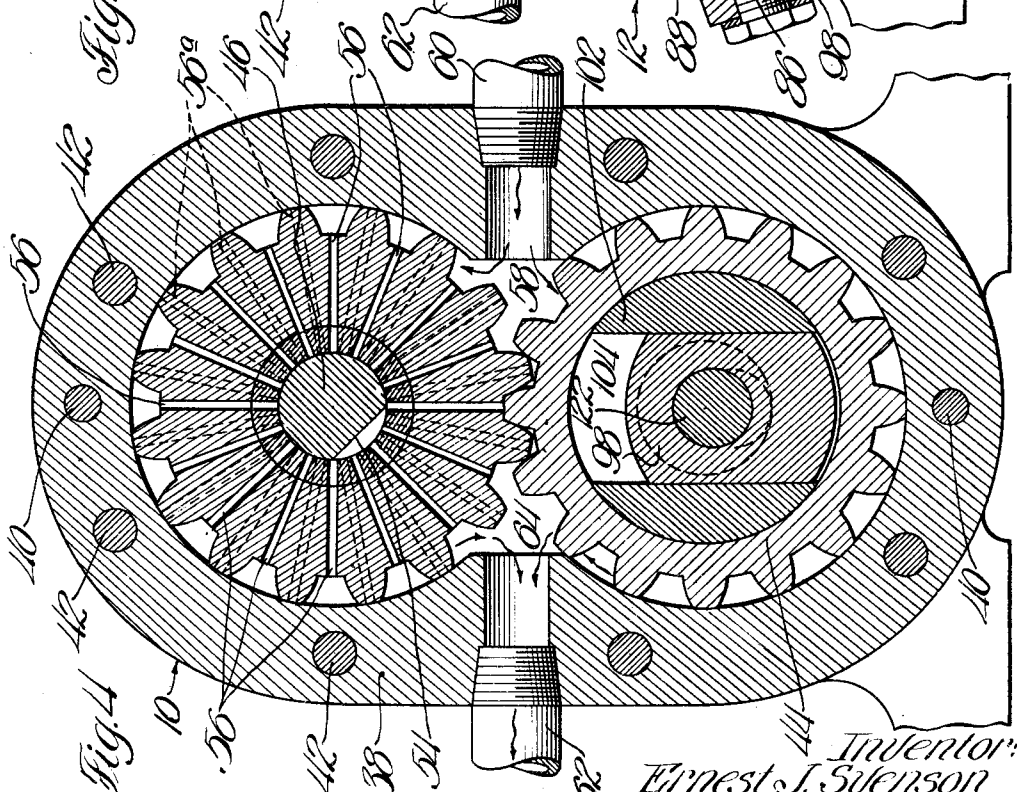

Fig. 4

Inventor:
Ernest J. Svenson
By Cheever, Cox & Moore (Attys.)

UNITED STATES PATENT OFFICE

1,978,480

PUMPING MECHANISM

Ernest J. Svenson, Rockford, Ill.

Application June 20, 1930, Serial No. 462,467

26 Claims. (Cl. 103—5)

My invention relates generally to fluid propelling mechanisms, and particularly to the type for controlling fluid which is used as a propelling medium. Present day industries are particularly interested in using machinery which is compactly arranged in order to eliminate the necessity of taking up extensive floor space, and in order to facilitate the adjustment, assembly, disassembly, replacements, etc., of the constituent parts. Compactness in design is particularly desirable in connection with machines which are hydraulically controlled. In using variable displacement pumps of the reciprocable piston type for propelling a fluid medium through a fluid system, a second pump is employed which serves to charge the plunger pump. Therefore it is desirable to arrange these pumps as compactly and conveniently as possible. In some instances gear pumps are employed to furnish a charging fluid to the plunger pump, and it is one of the primary objects of my present invention to provide a simple, compact, and convenient arrangement, whereby a charging pump such as a gear pump may be coupled with a plunger pump.

More specifically, my invention contemplates the provision of a self-contained structure, wherein a plunger pump is coupled with and operated in response to the actuation of a charging pump such as a gear pump.

Another object is to provide in combination with a plunger pump having a plurality of reciprocable pistons mounted within a stationary support and a central rotary driving means for actuating said pistons, a gear pump which is adjacently positioned and directly coupled with said rotary driving mechanism.

Still more specifically, my invention contemplates the provision of an improved, compact, self-contained pump structure, in which a variable delivery charging pump is directly coupled with a variable displacement high pressure plunger pump, one of said pumps being operable in response to the actuation of the other.

A further object is to provide a plunger pump of the type set forth above, having a laterally adjustable rotary driving mechanism, and a gear coupled thereto which forms one of the gears of a gear pump, said gear pump being employed for charging the pistons in said plunger pump.

These and numerous other objects and advantages will be more apparent from the following detailed description when considered in connection with the accompanying drawings, wherein—

Figure 1 is a central vertical sectional view of a pumping mechanism which is representative of

one embodiment of my invention, said view being taken substantially along the line 1—1 of Figure 5;

Figure 2 is a fragmentary transverse sectional view taken along the line 2—2 of Figure 1, disclosing the general arrangement of the rotary valve and the fluid conducting passageways communicating therewith;

Figure 3 is a fragmentary central sectional view taken longitudinally of the tapered valve and coupling therefor being shown in elevation in order to more clearly disclose the structural arrangement thereof;

Figure 4 is a transverse sectional view taken substantially along the line 4—4 of Figure 1; and

Figure 5 is also a transverse sectional view taken substantially along the line 5—5 of Figure 1.

Referring now to the drawings more in detail, wherein like numerals have been employed to designate similar parts through the various figures, it will be observed that my invention contemplates the provision of a pumping mechanism which is comprised chiefly of two pump units, one of said units comprising a gear pump which I have designated generally by the numeral 10, and another unit comprising a plunger pump which I have designated generally by the numeral 12. Certain of the structural features of these two pumps are similar to structures disclosed in my pending applications, Serial Nos. 430,867 and 430,868, filed February 24, 1930, and therefore a detailed description of the functional and structural characteristics of certain of the parts is not necessary to a thorough understanding of the present invention. My present invention is concerned chiefly with the presentation of a self-contained, compact "two-pump" arrangement, wherein a charging pump and a plunger pump are combined so as to provide a portable, unitary pump construction. It will be seen that my improved pumping mechanism includes an end casing or frame 14 and an oppositely disposed casing 16, Figure 1. Interposed between the upper portions of these casings 14 and 16 is a gear 18, said gear being mounted upon a sleeve 20, which sleeve is in turn secured to a head 22 by means of a pin 24. An extension of this head 22 provides a drive shaft 26, which passes through a suitable stuffing box 28 mounted within the casing 16. The shaft 26 is mounted within a suitable anti-friction roller bearing 30, and the sleeve 20 which projects beyond the extremity of the head 22 is mounted within a similar anti-friction roller bearing 32. Positioned adjacent the inner surfaces

of each of the casings 14 and 16 are spacer plates 34 and 36 respectively, and these spacer plates bear against the opposite sides of a central casing member 38. Pins or dowels 40 extending through the casing and spacer members serve to maintain said parts in proper alignment. In addition to these dowels 40, suitable bolts 42 serve to clamp the parts together. The spacer plates provide a chamber for accommodating the gear 18, as well as a companion annular gear 44 which meshes with the gear 18.

Positioned within the sleeve 20 is a cylindrical valve member 46, which is adapted to be rotatably adjusted by means of an external, manually operable lever 48. This lever 48 is secured to a stub shaft 50, the inner extremity of which has a tongue 52 which is received by a groove 52a in the valve member 46. A peripheral port 54 in the valve serves to control the flow of fluid from between meshing teeth of the gears 18 and 44. The gear 18 is provided with a plurality of radial ports or passageways 56 and 56a which are adapted to successively communicate with the valve port 54 during the rotation of the gear, thereby relieving against fluid pressures which would otherwise be developed between the meshing teeth.

Fluid is directed to an intake chamber 58 of the gear pump 10, Figure 4, from any suitable source (not shown) through a pipe 60. A pipe 62 serves to convey fluid from the discharge or high pressure chamber 64 of said pump to the intake chamber 66 of the plunger pump 12. This chamber 66 is housed within a suitable end casing 68, which is clamped against the end surface of an annular section 70 of the end frame 14. Fluid entering the chamber 66 from the gear pump 10 is directed through longitudinal passageways 72 of a tapered rotary fluid control valve 74, Figure 3, and these longitudinal passageways 72 communicate with a peripheral valve port 76. The tapered valve 74 is rotatable within a suitable tapered bearing 78 which is provided with radial ports 80, Figures 2 and 3.

Radiating and inclined from these radial ports 80 are passageways 82 which communicate with the outer extremities of piston chambers or cylinders 84. Pistons 86 are reciprocally mounted within these chambers 84, and a central driving mechanism including a driving ring 88, when eccentrically positioned, is adapted to impart movement to said pistons. Interposed between this driving ring and said pistons are pivoted fingers 90 which serve to prevent side thrust from being imparted to said pistons.

During the reciprocation of these pistons, fluid is directed from the peripheral valve port 76 to the radial passageways 82 communicating therewith, and fluid from the other passageways 82 is directed to a second peripheral valve port 76a, which communicates by means of a valve passageway 92 with an annular port 94. This port 94 communicates with a discharge pipe 96, which is adapted to be connected at any point where a propelling fluid medium is required.

The inner end of the tapered valve 74 makes a tongue and groove connection with the adjacent extremity of a driving member 98, which supports the driving ring 88. Interposed between the driving ring 88 and the rotary supporting member 98 are friction reducing balls 100. This rotary driving member 98 is laterally shiftable within and driven by a journal or sleeve 102, said sleeve being provided with transverse slots 104 and 106 for slidably receiving companion portions of the member 98. The sleeve 102 is keyed to the an-

nular gear 44 and is rotatably mounted within anti-friction bearings 108 and 110, Figure 1. An anti-friction thrust bearing 112 is interposed between one extremity of the sleeve 102 and an annular abutment 114 formed integral with an adjusting nut 116. Positioned on the opposite side of this annular abutment 114 is a collar 118 which is secured to the outer extremity of a longitudinally shiftable adjusting member 120. This member 120 is of cylindrical form and is longitudinally shiftable within the sleeve 102. The inner extremity of the member 120 is provided with an extension 122, which extends into a companion cylindrical recess 124 provided in the laterally shiftable driving member 98. Thus, in response to the longitudinal shifting of the member 120 within the sleeve 102, lateral movement will be imparted to the driving ring 88, thereby varying the stroke of the pistons 86 within their stationary housing or support. The nut 116 which is screwed within the casing 16, is manually operable from a point externally of the casing for the purpose of imparting longitudinal movement to the adjusting member 120. By means of suitable micrometer graduations, the longitudinal shifting of the nut 116 may be accurately determined.

From the foregoing it will be apparent that my invention provides a very compactly arranged "two-pump" arrangement, wherein two pumping devices, one a gear pump for supplying fluid at charging pressures and the other a high pressure plunger pump of improved practical construction for receiving charging fluid from said gear pump, are included within a single housing or casing structure. Rotation is imparted to the drive shaft 26 from any suitable source of power supply (not shown), such for example as a rotatable element of a lathe, milling machine, or the like, and rotation of this drive shaft imparts rotation to the gear pump, as well as to the plunger pump. By my improved compact construction, long pipe lines are eliminated and the number of pump elements is materially reduced, thereby providing a very economical construction from the standpoint of manufacture. By using pumps of the delivery type here disclosed, and by having simple, externally positioned, manually operable adjusting means, the charging pressure, as well as the pressure of the fluid discharged from the plunger pump, may be conveniently and accurately controlled in accordance with the requirements of the machine with which the pumping device may be associated. The adjustment for displacement of these pumps may be made during the operation of the pumps, and this is also decidedly advantageous. There are no elements of complicated design which would have a tendency of getting out of order, and all adjustments, replacements, and the like may be made in a very convenient and expeditious manner. The fact that one of the gears of the gear pump is adapted to form a driving element of the plunger pump, enables a material reduction in the number of parts required to operate said pumps. In other words, my invention contemplates the provision of a combined pumping arrangement wherein a driving means, such as a sleeve 102 and the laterally adjustable driving member 98, serves to directly couple a charging pump, such as a gear pump, with a variable displacement pump, such as a plunger pump.

Obviously various modifications and changes in structural features may be made without departing from the spirit and scope of my present

invention, and said invention should be limited only by the scope of the appended claims.

Having thus described my invention, what I claim as new and desire to secure by Letters Patent is:

1. In a fluid propelling mechanism, stationary supporting means, a single row of annularly disposed and radially reciprocable pistons therein for receiving fluid under a given pressure and discharging said fluid under another pressure, rotary driving means for imparting movement to said pistons, said pistons being in continuous engagement with said driving means, irrespective of the stroke experienced by said pistons, a charging pump operatively connected with said rotary driving means for delivering fluid to said pistons, means for varying the stroke of said single row of pistons to vary the fluid displacement, and means for directing fluid from the discharge side of said charging pump to said reciprocable pistons.

2. In a fluid propelling mechanism, stationary supporting means, a plurality of radial reciprocable pistons therein for receiving fluid under a given pressure and discharging said fluid under another pressure, rotary driving means for imparting movement to said pistons, a variable delivery charging pump operatively connected with said rotary driving means for delivering fluid to said pistons, control means within the charging pump for governing the rate of fluid delivery before said fluid emerges from said charging pump, and means for directing fluid from the discharge side of said variable delivery charging pump to said reciprocable pistons.

3. In a fluid propelling mechanism, stationary supporting means, a single row of annularly disposed and radially reciprocable pistons therein for receiving fluid under a given pressure and discharging said fluid under another pressure, rotary driving means for imparting movement to said pistons and in continuous contact therewith, a variable delivery gear pump operatively connected with said rotary driving means for delivering fluid to said pistons, and means for directing fluid from the discharge side of said gear pump to said reciprocable pistons.

4. In a fluid propelling mechanism, stationary supporting means, a plurality of radial reciprocable pistons therein for receiving fluid under a given pressure and discharging said fluid under another pressure, rotary driving means for imparting movement to said pistons, a gear pump operatively connected with said rotary driving means for delivering fluid to said pistons, one of the gears in said pump being positioned in axial alinement with said rotary driving means, and means including a rotary valve mechanism for directing fluid from the discharge side of said gear pump to said reciprocable pistons.

5. In a fluid propelling mechanism, stationary supporting means, a plurality of radial reciprocable pistons therein for receiving fluid under a given pressure and discharging said fluid under another pressure, unitary valve means for controlling the flow of fluid toward and away from said pistons, rotary driving means for imparting movement to said pistons, a charging pump operatively connected with said rotary driving means for delivering fluid to said pistons, and means for directing fluid from the discharge side of said charging pump to the means for controlling the flow of fluid toward and away from said pistons.

6. In a fluid propelling mechanism, a gear pump, a plunger pump coupled with one of the gears of said gear pump, the plungers of said

plunger pump being spaced from the structure of said gear pump, means for directing fluid from the discharge side of said gear pump to said plunger pump, said propelling mechanism being connectible with a suitable source of power supply, and a laterally adjustable driving means for imparting movement to said pistons.

7. In a fluid propelling mechanism, a plunger pump including a stationary plunger support having a plurality of plungers radiating from a common axis, a gear pump for charging said plunger pump, the axis about which the plungers are disposed being coincident with the axis of one of the gears of said gear pump, means for coupling said last mentioned gear with said plunger pump, means for directing fluid from the discharge side of said gear pump to said plunger pump, said propelling mechanism being connectible with a suitable source of power supply, and a laterally adjustable driving means for imparting movement to said pistons.

8. In a fluid propelling mechanism, a plunger pump having a plurality of radially reciprocable plungers for receiving fluid under a given pressure and discharging said fluid under another pressure, a laterally shiftable rotary driving means for said plungers, the lateral shifting of said driving means serving to vary the stroke of said plungers, a gear pump for charging said plungers, said laterally shiftable plunger actuating means being coupled with one of the gear of said charging pump, and means for directing fluid from the discharge side of said charging pump to said plunger pump.

9. In a fluid propelling mechanism, a plunger pump having a plurality of radially reciprocable plungers for receiving fluid under a given pressure and discharging said fluid under another pressure, means for imparting movement to said pistons, a charging pump for delivering fluid under charging pressure to said plunger pump, said charging pump being coupled with said plunger actuating means, said coupling means including a support rotatable about a fixed axis and means driven thereby and shiftable laterally thereof for imparting movement to said plungers, and means for directing fluid from said charging pump to said plungers.

10. In a fluid propelling mechanism, a plunger pump having a plurality of radially reciprocable plungers for receiving fluid under a charging pressure and delivering said fluid under another pressure, means for imparting movement to said plungers, unitary valve means for controlling the flow of fluid toward and away from said plungers, a charging pump for delivering fluid to said plunger pump, said charging pump being coupled with said plunger actuating means, and means for directing fluid from said charging pump to said control valve.

11. In a fluid propelling mechanism, a plunger pump having a plurality of radially reciprocable plungers for receiving fluid at a charging pressure and delivering said fluid at another pressure, rotary driving mechanism for imparting movement to said plungers, a gear pump for delivering fluid under a charging pressure, one of the gears of said pump being of annular construction, said rotary driving mechanism including a sleeve member extending within the opening in said annular gear and coupled to said gear, and means for directing fluid from the discharge side of said gear pump to said plunger pump.

12. In a fluid propelling mechanism, a plunger pump having a plurality of radially reciprocable

- plungers for receiving fluid at a charging pressure and delivering said fluid at another pressure, rotary driving mechanism for imparting movement to said plungers, a gear pump for delivering
- 5 fluid under a charging pressure, one of the gears of said pump being of annular construction, said rotary driving mechanism extending within the opening in said annular gear and coupled to said gear, means for directing fluid from the discharge
- 10 side of said gear pump to said plunger pump, and means for laterally shifting a portion of said driving mechanism to vary the stroke of said plungers.
13. A pumping unit including a housing, a
- 15 plunger pump within said housing, means manually operable from a point externally of the housing for varying the stroke of the plungers to correspondingly vary the displacement of said plunger pump, a gear pump enclosed within said
- 20 housing for charging said plunger pump, one of the gears of said gear pump being directly coupled with said plunger pump, and means controllable from a point externally of the housing for adjusting the delivery of said gear pump independently of the means for adjusting the displacement of said plunger pump.
14. A pumping construction including a piston support, a plurality of radially disposed pistons in said support, a rotary valve whose axis is positioned in substantial parallelism with the axis
- 30 about which the pump pistons radiate for controlling the delivery and discharge of fluid to and from said pistons, a housing, a gear pump in said housing including a gear positioned in substantial alignment with respect to the axis about which the pistons radiate, and means connecting the discharge side of said gear pump with the intake side of said plunger pump.
15. A pumping construction including a piston support, a plurality of radially disposed pistons in said support, a rotary valve whose axis is positioned in substantial parallelism with the axis about which the pump pistons radiate for controlling the delivery and discharge of fluid to and
- 45 from said pistons, a housing, a gear pump in said housing, rotary driving means for said plunger pump including a laterally shiftable section for varying the stroke of said pistons, one of the gears in said gear pump being mechanically coupled with said driving means, the axis of said gear, driving means, and rotary valve being substantially coincident, and means for conducting fluid from the discharge side of the gear pump to the intake side of the plunger pump.
- 50 16. A pumping construction including a piston support, a plurality of radially disposed pistons in said support, a rotary valve whose axis is positioned in substantial parallelism with the axis about which the pump pistons radiate for controlling the delivery and discharge of fluid to and from said pistons, a housing, a gear pump in said housing, rotary driving means for said plunger pump including a laterally shiftable section for varying the stroke of said pistons, one of the gears in said gear pump being mechanically coupled with said driving means, the axis of said gear, driving means, and rotary valve being positioned in substantial parallelism, and means for conducting fluid from the discharge side of the gear
- 65 pump to the intake side of the plunger pump.
17. In a fluid pump, piston supporting means, a plurality of pistons radially reciprocable therein, a gear pump for delivering fluid to said pistons, and an adjustable driving mechanism for imparting movement to said pistons, a portion at
- least of said driving means extending within and driven by one of the gears of said gear pump.
18. In a fluid pump, piston supporting means, a plurality of pistons radially reciprocable therein, a gear pump for delivering fluid to said pistons, an adjustable driving mechanism for imparting movement to said pistons, a portion at least of said driving means extending within one of the gears of said gear pump, and means positioned within one of the gears of said gear pump for varying the fluid delivery of said pump.
19. In a pumping mechanism, a support, a plurality of pistons radially reciprocable within said support, driving means therefor, said driving means being laterally shiftable for varying the displacement of fluid by said pistons, means for effecting the shifting of said driving means during the operative functioning thereof, a gear pump for delivering fluid to said pistons, and means for varying the fluid delivery of said gear pump during the functioning of said pistons, whereby the fluid delivery of said gear pump may be adjusted in accordance with any variation in fluid displacement of the other pump during the operative functioning of the latter.
20. In a fluid propelling mechanism, stationary supporting means, a single row of annularly disposed and radially reciprocable pistons therein for receiving fluid under a given pressure and discharging said fluid under another pressure, rotary driving means for imparting movement to said pistons, said rotary driving means being laterally shiftable for varying the stroke setting of said pistons, said pistons being in continuous engagement with said driving means irrespective of the stroke experienced by said pistons, a second pump operatively connected with said rotary driving means for delivering fluid to said pistons and for maintaining fluid pressure at the end of the pistons oppositely disposed from the rotary driving means whereby to maintain said pistons in continuous engagement with said driving means, means for laterally shifting said rotary driving means to vary the fluid displacement, and means for directing fluid from said second pump to said reciprocable pistons.
21. In a fluid propelling mechanism, stationary supporting means, a single row of annularly disposed and radially reciprocable pistons therein for receiving fluid under a given pressure and discharging said fluid under another pressure, rotary driving means for imparting movement to said pistons and in continuous contact therewith, said driving means being laterally shiftable for varying the stroke setting of said pistons, a variable delivery gear pump operatively connected with said rotary driving means for delivering fluid to said pistons at the extremity thereof oppositely disposed from said rotary driving means whereby to maintain a fluid pressure against the pistons and thereby cause said pistons to continuously maintain contact with said driving means and to deliver fluid to the pistons in accordance with the stroke setting thereof, and means for directing fluid from said gear pump to said reciprocable pistons.
22. In a fluid propelling mechanism, a plunger pump having a plurality of radially reciprocable plungers for receiving fluid under a given pressure and discharging said fluid under another pressure, a laterally shiftable rotary driving means for said plungers, the lateral shifting of said driving means serving to vary the stroke of said plungers, a gear pump for delivering fluid to the extremity of the plungers oppositely dis-

posed from said rotary driving means to thereby continuously urge said plungers into operative engagement with said rotary driving means, said laterally shiftable plunger actuating means being coupled with one of the gears of the gear pump, and means for directing fluid from the gear pump to said plungers.

23. In a fluid propelling mechanism, stationary supporting means, a plurality of radial reciprocable pistons therein for receiving fluid under a given pressure and discharging said fluid under another pressure, rotary driving means for imparting movement to said pistons, a gear pump operatively connected with said rotary driving means for delivering fluid to said pistons, one of the gears in said pump being positioned in axial alinement with said rotary driving means, and means including unitary valve mechanism for directing fluid from the discharge side of said gear pump to said reciprocable pistons.

24. In a fluid propelling mechanism, stationary supporting means, a plurality of radial reciprocable pistons therein for receiving fluid under a given pressure and discharging said fluid under another pressure, unitary valve means for controlling the flow of fluid toward and away from said pistons, adjustable rotary driving means for imparting movement to said pistons, said valve means being operable in synchronism with said driving means irrespective to its posi-

tion of adjustment, a charging pump operatively connected with said rotary driving means for delivering fluid to said pistons, and means for directing fluid from the discharge side of said charging pump to the means for controlling the flow of fluid toward and away from said pistons.

25. In a pumping mechanism, a support, a plurality of pistons radially reciprocable within said support, driving means therefor, said driving means being laterally shiftable for varying the displacement of fluid by said pistons, means for effecting the shifting of said driving means during the operative functioning thereof, a variable pressure gear pump for delivering fluid at various pressures to said pistons, and means for controlling the pressure of the fluid delivered by said gear pump during the functioning of said pistons.

26. In pumping mechanism, a support, a plurality of pistons radially reciprocable within said support, driving means therefor, said driving means being adjustable for varying the stroke of said pistons, means for effecting the adjustment of said driving means during the operative functioning thereof, a gear pump for delivering fluid to said pistons, and means for varying the fluid delivery of said gear pump to meet the stroke requirements of said pistons and for varying the effectiveness of the fluid upon said pistons.

ERNEST J. SVENSON.

35	110
40	115
45	120
50	125
55	130
60	135
65	140
70	145
	150