

A. W. PUFFER & G. W. HAYES,
GRINDER HEAD.

APPLICATION FILED MAR. 16, 1908.

931,483.

Patented Aug. 17, 1909.

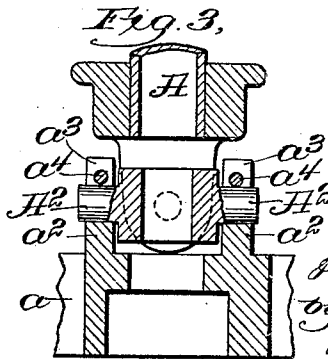
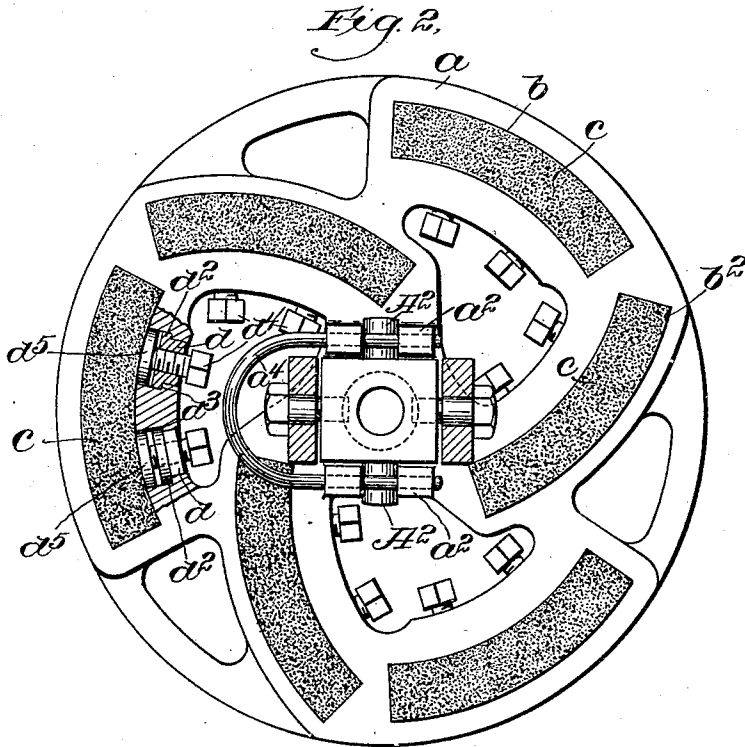
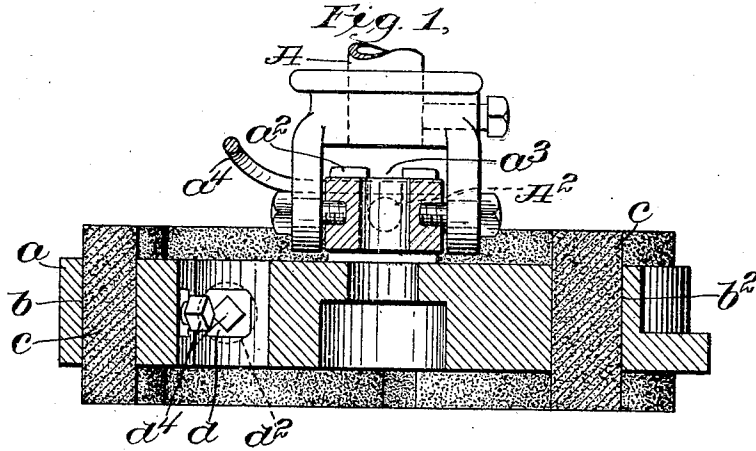

Witnesses:
Jas. Maloney.
J. Maloney.

Inventors:
Alvin W. Puffer,
& George W. Hayes,
by *J. P. and H. J. ...*
Attys.

UNITED STATES PATENT OFFICE.

ALVIN W. PUFFER, OF MEDFORD, AND GEORGE W. HAYES, OF WINCHESTER, MASSACHUSETTS, ASSIGNORS TO PUFFER MANUFACTURING COMPANY, A CORPORATION OF MAINE.

GRINDER-HEAD.

No. 931,483.

Specification of Letters Patent.

Patented Aug. 17, 1909.

Application filed March 16, 1908. Serial No. 421,345.

To all whom it may concern:

Be it known that we, ALVIN W. PUFFER and GEORGE W. HAYES, both citizens of the United States, and residents, respectively, of Medford, county of Middlesex, and State of Massachusetts, and of Winchester, county of Middlesex, and State of Massachusetts, have invented an Improvement in Grinder-Heads, of which the following description, in connection with the accompanying drawings, is a specification, like letters on the drawings representing like parts.

The present invention relates to a grinder head, and is embodied in a rotating grinder of the kind which is used in connection with the process of surfacing or dressing marble slabs, and the like, the head being connected with a vertically rotating member of the machine which in turn is connected with a movable overhanging arm, so that the grinder, while rotating, can be manipulated by the attendant and moved about over the face of the slab. During the grinding process, the face of the marble is plentifully supplied with water, the vertical rotating shaft of the machine to which the grinder is connected being commonly utilized as a feed pipe, so that a stream of water is fed through the middle of the grinder on the surface which is being dressed or polished. In a grinder of this kind, it is desirable, first, that there should be plenty of space around the actual grinding surface for the free circulation of water; second, a good distribution of the grinding surface so as to afford a firm support for the grinder when part of the grinder is moved past the edge of the slab upon which it is working; and, third, a convenient means for connecting and disconnecting the grinder head from the rotating actuating shaft of the machine, for the reason that a number of grinders having grinding surfaces of different qualities are used in polishing a single piece of material.

The grinder head embodying the invention comprises a skeleton frame in the general form of a disk, this frame being made of any suitable material, preferably cast iron. The frame is provided with sockets to contain pieces of grinding material which are in the form of segments, it being practicable to form the six grinding members employed by casting an annular piece of emery, carborundum, or the like, and cutting the said piece into six equal parts. The sockets for the

parts in the grinder head are the same in shape, and three of the sockets are arranged along the periphery of the head, substantially equally spaced, while the other three sockets which alternate therewith are transverse, so that the grinding members contained therein project from the periphery inward toward the middle of the wheel. This gives a grinding surface to which the marble is exposed, when the head is rotating, which surface extends from the periphery of the wheel approximately two-thirds of the distance to the center thereof and, at the same time, affording plenty of space for the distribution of the cooling medium. The head may further be made in skeleton shape, thus affording plenty of room for clamping nuts projecting through the walls of the sockets, so that the blocks of grinding material can not only be readily replaced, but can also be adjusted from time to time to take up wear and to keep the aggregate grinding surface on an even level.

A further feature of the invention consists in a simple and easily operated attaching device for holding the grinder head on the actuating shaft of the machine.

Figure 1 is a vertical section through a grinder head embodying the invention, showing the lower portion of the actuating shaft of the machine; Fig. 2 is a plan view with a portion of the shaft of the machine shown in section above the top of the grinder head; and Fig. 3 is a detail, in vertical section, taken on a plane transverse to that of Fig. 2.

The head *a*, which is generally circular in shape, consists preferably of a skeleton casting provided with three sockets *b* arranged along the periphery of the wheel and three sockets *b*² which start from the periphery and extend inward toward the middle. These sockets are all of the same shape and size, so as to be capable of containing grinding members *c* of emery or carborundum, or similar material, which members are alike in size and shape and consequently interchangeable. The six members may conveniently be made by sawing a single annular member into six equal parts, this being a convenient way of getting the members uniform in size and shape. The head *a* is in skeleton form, so that the walls of the sockets *b* and *b*² are exposed; and the grinding members *c* can, therefore, be clamped in position by means of clamping members which

are accessible at the outside of the said exposed walls. As best shown in Fig. 2, the clamping members consist of hardened steel thimbles d provided with flanges d^2 which rest against shoulders d^3 formed in the walls of the sockets, the said thimbles having bolts d^4 screwed therein and arranged to engage clamps or followers d^5 which rest against the sides of the grinding blocks c . The blocks, therefore, can readily be inserted in the sockets and then clamped firmly in position, it being obvious, moreover, that, as the blocks wear away, they can be adjusted in the sockets so as to project the necessary distance beyond the lower surface of the grinding head itself. It will be seen that by this arrangement the grinding surface, that is, the effectual grinding surface while the head is rotating, extends a considerable distance from the periphery of the wheel toward the center, there being, at the same time, ample space for the distribution of cooling liquid along the surface which is being operated upon.

In order that the grinder heads may be readily attached to and detached from the vertically rotating shaft A, each head is provided with upwardly projecting lugs a^2 which are bifurcated to afford recesses a^3 to receive projecting members or trunnions A^2 which project laterally from the shaft A, and when the trunnions A^2 are dropped into the recesses a^3 , it will be seen that the two parts are connected together so far as relates to the rotating movement, and in order to keep them from endwise displacement, the lugs a^2 are provided with bores or openings to receive a key a^4 which is preferably in the form of a U-shaped rod, as best indicated in Fig. 2.

Claims.

1. A grinder head comprising a skeleton disk provided with a plurality of equally spaced recesses parallel to the periphery of said disk to receive segmentally shaped grinding members; and also with an equal number of recesses of the same shape and size as those parallel to the periphery and located between them and extending from

the periphery inward toward the middle of the disk; and grinding members conforming in shape to and detachably secured in said recesses.

2. A grinding head comprising a skeleton disk provided with six recesses substantially equal in shape and size, three of said recesses being equally spaced apart and located parallel to the periphery of the head, and the other three recesses being located between the recesses first named and inclined inward from the periphery toward the middle, the skeleton formation of the disk being such that the spaces between said recesses are accessible; blocks of grinding material contained in said recesses; and clamping devices having actuating portions accessible at the outside of the walls of said recesses, substantially as described.

3. A grinding head comprising a skeleton disk having six recesses each of which is shaped to conform to and adapted to contain a grinding member formed by equally dividing into six parts an annular block of grinding material, three of said recesses being equally spaced and lying parallel to the periphery of said disk, the other three recesses extending inward from said periphery; and means for adjustably clamping said grinding portions in said recesses, substantially as described.

4. A grinding head having a grinding surface and a holder to retain the material of which said grinding surface is formed, combined with bifurcated lugs projecting upward above said holder to receive transverse projections connected with the rotating shaft to be revolved thereby, said lugs being provided with transverse openings; and a U-shaped retaining wire, the ends of which are adapted to be inserted in said openings in the lugs.

In testimony whereof, we have signed our names to this specification in the presence of two subscribing witnesses.

ALVIN W. PUFFER.
GEORGE W. HAYES.

Witnesses:

JAMES J. MALONEY,
M. E. COVENEY.