

[72] Inventor **Harold L. Gordon**
 1529 First St., Youngstown, Ohio 44509
 [21] Appl. No. **60,457**
 [22] Filed **Aug. 3, 1970**
 [45] Patented **Nov. 9, 1971**

[56] **References Cited**
UNITED STATES PATENTS
 1,604,492 10/1926 Smith 417/40
Primary Examiner—Carlton R. Croyle
Assistant Examiner—Richard J. Sher
Attorney—Webster B. Harpman

[54] **WATER SUPPLY AND PUMP FOR FOUNTAINS**
 3 Claims, 3 Drawing Figs.
 [52] U.S. Cl. **417/40,**
 137/412, 137/428, 239/20, 239/23
 [51] Int. Cl. **F04b 49/04**
 [50] Field of Search 417/40;
 137/412, 428; 239/20, 23

ABSTRACT: A water supply and pump for fountains is disclosed which includes a cylindrical container for holding the water supply, pump means for moving the water supply from the container to a fountain and means for returning the water from the fountain to the container controlled by a float valve responsive in operation to the level of water in the container, a secondary float valve biases the first float valve to effect a cycle in the pumping action and switch means controlled by the first float valve controls the pumping means.

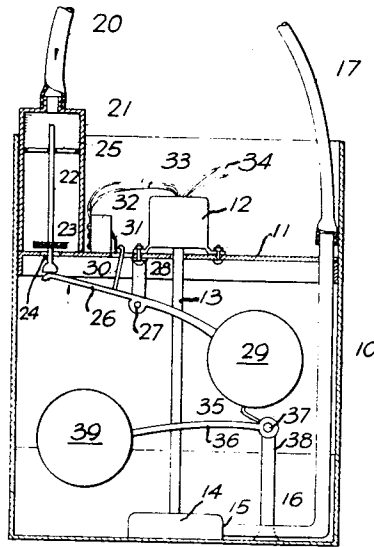

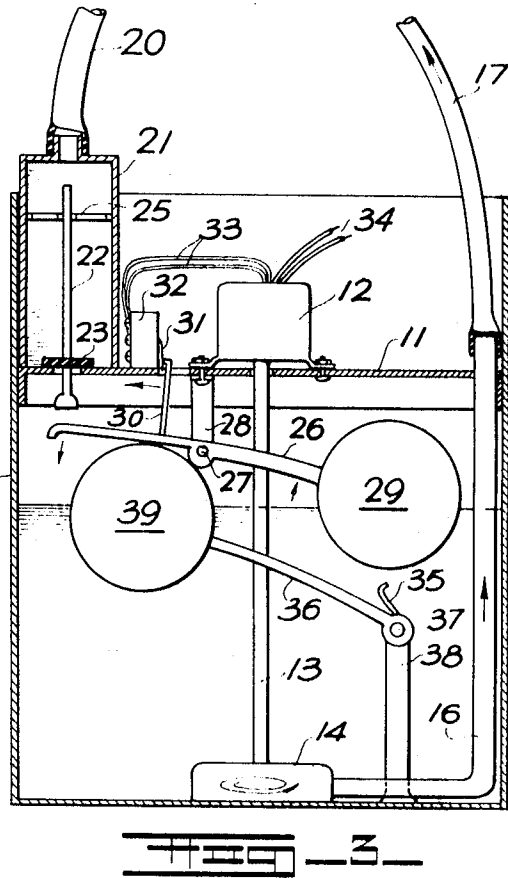
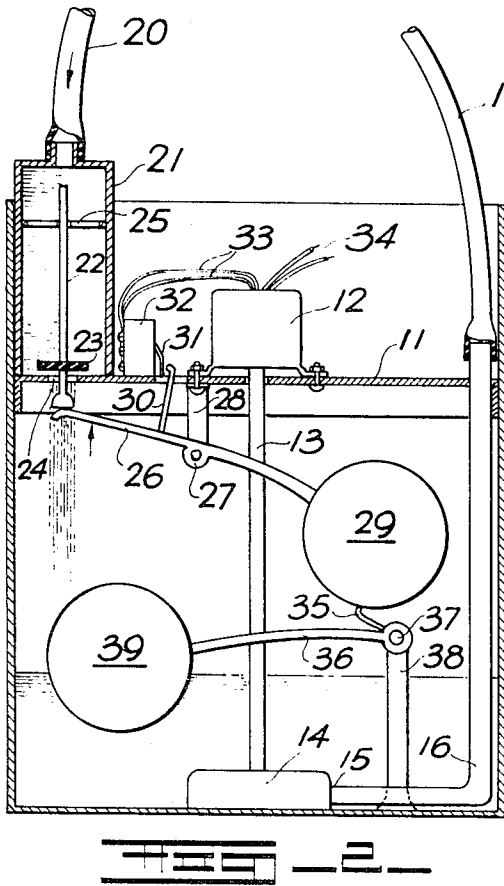
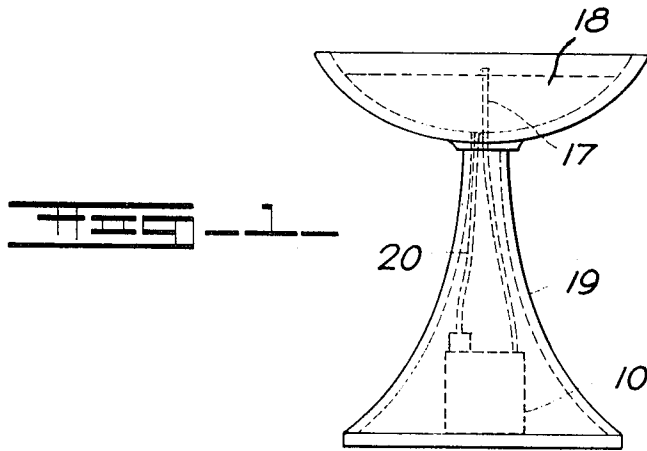

Inventor
Harold L. Gordon.

By *W. B. Hanson*

Attorney

WATER SUPPLY AND PUMP FOR FOUNTAINS

BACKGROUND OF THE INVENTION

1. Field of the Invention

This invention relates to water fountains and pumps therefor wherein a supply of water is recirculated to and from the fountain.

2. Description of the Prior Art

Prior structures of this type usually employ a continuously running pump which operates whether or not there is water in the supply reservoir with the resulting cavitation of the pump at times and undesirable operating reactions thereto. Some prior art structures disclose fountains supplied by control valves responsive to the water level in the fountain and dependent upon a separate water supply source (see U.S. Pat. Nos. 2,628,631 and 3,306,263).

This invention eliminates such valves in the fountain area and dependence on a separate water supply and provides a simple inexpensive device which circulates the water to the fountain only when there is a water supply in the reservoir thereof.

SUMMARY OF THE INVENTION

A water supply and pump for fountains includes a container for a water supply, a pump driven by an electric motor for circulating water from the container to the fountain and a novel valving arrangement whereby water from the fountain returns to the container by way of a valve chamber which in turn is controlled with respect to its communication with the container by a float valve. The same float valve operates a switch controlling the pump motor. A secondary float valve biases the first float valve with the result that a satisfactory supply of water in the reservoir is always maintained and at such time as the supply should be exhausted the pumping action is automatically terminated.

DESCRIPTION OF THE DRAWINGS

FIG. 1 is a side elevation of a fountain with broken lines showing the location therein of the water supply and pump for the same.

FIG. 2 is a vertical section through the water supply and pump device showing a low water level in the device and the pump inoperative.

FIG. 3 is a vertical section through the water supply and pump device showing a high water level in the device and the pump operative.

DESCRIPTION OF THE PREFERRED EMBODIMENT

In its simplest form the water supply and pump for fountains comprises a container 10 which is preferably cylindrical and which may obviously be formed of inexpensive molded plastic. A shelflike partition 11 extends horizontally across the container 10 inwardly of the upper end and supports a small fractional horsepower electric motor 12, the driven shaft 13 of which is extended downwardly through the partition 11 and engaged in a centrifugal pump 14. The water inlet of the pump 14 is in its central upper portion and the outlet 15 is in its annular side and communicates with a tube 16 which extends upwardly and through the partition 11 where it connects with flexible tube 17 which leads upwardly to a jet or similar nozzle in the fountain.

The fountain is shown in FIG. 1 of the drawings and includes a bowl 18 positioned on a stand 19 and broken lines indicate the location of the container 10. Water from the bowl 18 flows downwardly through a secondary flexible tube 20 and into a cylindrical valve housing 21 which is positioned on the partition 11. A vertically acting valve stem 22 in the valve housing 21 has a valve element 23 thereon which registers with a valve seat 24 defining an opening in the partition 11 and establishing communication between the valve housing 21 and the container 10 below the partition 11. A guide member 25 in the valve housing 21 guides the upper end of the valve stem 22

and the lower end of the valve stem 22 has an enlarged end portion which is adapted to be engaged by one end of a lever arm 26 which is pivoted at 27 to a bracket 28 carried by the partition 11. The other end of the lever arm 26 carries a first float 29.

A finger 30 formed on the lever arm 26 extends upwardly through an opening in the partition 11 and is positioned for engagement with the actuating arm 31 of a microswitch 32 which is mounted on the partition 11 adjacent the motor 12. Circuit wires 33 connect the switch 32 in a control circuit with respect to the power supply wires 34 by means of which electrical energy is delivered to the electric motor 12. The electric motor 12 is thus operated responsive to the position of the first float 29 and as illustrated in FIG. 2 of the drawings the finger 30 is spaced from the actuating arm 31 of the microswitch 32 and the motor 12 is inoperative and no water is being circulated by the centrifugal pump 14.

When the float 29 is in the position shown in FIG. 2, it is supported against further downward motion by a secondary finger 35 formed on a secondary arm 36 which is pivoted at 37 to a support 38 in the container 10. A secondary float 39 on the secondary arm 36 moves responsive to the water level in the container 10 and moves the secondary finger 35 into and out of supporting position with respect to the first float 29.

Still referring to FIG. 2 of the drawings it will be seen that in the positions illustrated with respect to the floats 29 and 39 the electric motor will be inoperative and the valve element 23 will be open and water from the bowl 18 in the valve housing 21 will flow into the chamber 10.

It will be seen that the opening of the valve element 23 is responsive to two conditions which are dependent upon the level of the water supply in the container 10. When the water supply is at a high level as shown in FIGS. 3 of the drawings the valve element 23 will be closed and water from the bowl 18 of the fountain returns to the valve housing 21. As the water level begins to fall due to the operation of the pump 14 which is operating when the water level is high as seen in FIG. 3, the falling of the float 29 progressively opens the valve element 23. If the degree of opening is not sufficient to maintain the water level in the container 10 the downward movement of the first float 29 will be stopped by the secondary finger 35 controlled by the secondary float 39 which will then be in its uppermost position and as the secondary float 39 begins to move downwardly with the water level, the movement of the secondary finger 35 will permit the first float 29 to move lower and hence open the valve element 23 to its full open position. If the water level continues to fall more rapidly than it is being returned the finger 30 moves away from the actuating arm 31 of the microswitch 32 and the motor 12 and pump 14 become inoperative until such time as the water level again rises and the reverse motion of the floats 29 and 30 occurs whereupon the motor 12 and pump 14 again start up and the valving action of the valve 23 in the valve housing 21 again attempts to control the water level in the container 10.

It will thus be seen that the mechanism of the water supply and pump device is self-adjusting and that under normal conditions it continues to operate continuously. Variations in the amount of water in the bowl 18 in the output of the pump 14 result in the aforesaid conditions and operations responsive thereto.

Although but one embodiment of the present invention has been illustrated and described it will be apparent to those skilled in the art that various changes and modifications may be made therein without departing from the spirit of the invention.

I claim:

1. A water supply and pump for a fountain comprising a container, a pump in said container and a motor therefor for moving water from said container to said fountain, a valve housing and valve operable therein for returning water to said container, from said fountain, float means in said container moving said valve in said valve housing and arranged to vary the position of said valve responsive to the level of water in

3

4

said container, a power source for said motor and means connecting said motor therewith, switch means in said connecting means responsive in operation to said float means.

2. The water supply and pump for fountains set forth in claim 1 and wherein said valve housing forms a first water receiving chamber.

3. The water supply and pump for fountains set forth in

claim 1 and wherein the float means comprises a lever arm, a first float pivoted to said lever arm, said lever arm arranged to engage said valve, a second arm, a second float on said second arm having a finger movable into engagement with said first float to bias the position thereof at various water levels in said container.

* * * * *

10

15

20

25

30

35

40

45

50

55

60

65

70

75