

12 **EUROPEAN PATENT APPLICATION**

21 Application number: 83305723.5

51 Int. Cl.<sup>3</sup>: E 06 C 7/16

22 Date of filing: 26.09.83

30 Priority: 14.10.82 GB 8229452

43 Date of publication of application:  
25.04.84 Bulletin 84/17

88 Date of deferred publication of search report: 18.07.84

84 Designated Contracting States:  
BE CH DE FR GB IT LI NL SE

71 Applicant: **Rayment, David John**  
46 Churchill Crescent Wickham Market  
Woodbridge Suffolk(GB)

72 Inventor: **Rayment, David John**  
46 Churchill Crescent Wickham Market  
Woodbridge Suffolk(GB)

74 Representative: **Dummett, Thomas Ian Peter**  
7 Hasketon Road  
Woodbridge Suffolk IP12 4JT(GB)

54 **Device for mounting on the rung of a ladder-like member.**

57 The device comprises a generally rectangular and planar load-bearing member (10) having, preferably at or adjacent one edge thereof, means (12) for engaging a rung (3) of the ladder-like member (1 and 2) and for locating the planar member (10) on the ladder-like member (1 and 2) so that it can be pivoted about the rung (3) on which it is located, the planar member (10) also being provided with a stay (20) adapted to engage with another rung (3) of the ladder-like member (1 and 2) and to retain the planar member (10) extended from the plane of the ladder-like member (1 and 2) and thus form a platform for a user of the ladder-like member (1 and 2). The stay (20) comprises a pair of arms (21) pivotably mounted on the planar member (10) at or adjacent the edge opposed to the rung engaging means (12), each arm (21) carrying means (25) for engaging a rung (3) of the ladder-like member (1 and 2), the arms (21) being spaced apart by a distance not significantly less than the lateral width of the planar member (10), whereby the arms (21) can be disengaged from the rung (3) to permit the planar member (10) and the arms (21) to lie substantially parallel to the plane of the ladder-like member (1 and 2) with the arms (21) lying to either side of a planar member (10) mounted on a lower rung (3) of the ladder-like member (1 and 2).

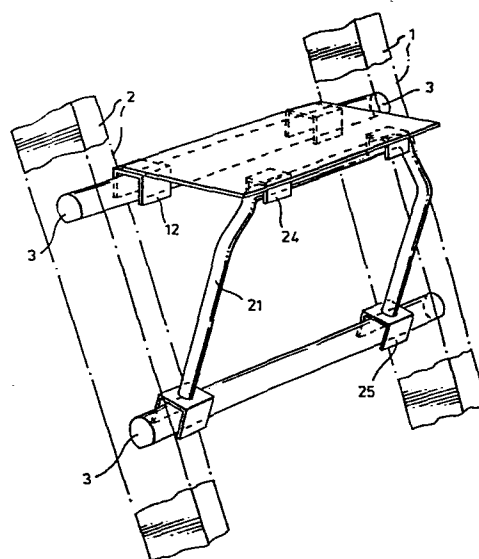

Fig. 1.

