

**EUROPEAN PATENT APPLICATION**

Application number: **90105508.7**

Int. Cl.<sup>5</sup>: **F24F 1/02**

Date of filing: **23.03.90**

Priority: **05.04.89 IT 2002389**

Applicant: **Bigarella, Armando**  
**Via Carlo Cattaneo 13**  
**I-20052 Monza (Milan)(IT)**

Date of publication of application:  
**10.10.90 Bulletin 90/41**

Inventor: **Bigarella, Armando**  
**Via Carlo Cattaneo 13**  
**I-20052 Monza (Milan)(IT)**

Designated Contracting States:  
**DE ES FR GB**

Representative: **Giambrocono, Alfonso, Dr.**  
**Ing. et al**  
**Ing. A. Giambrocono & C. S.r.l. Via Rosolino**  
**Pilo 19/B**  
**I-20129 Milano(IT)**

**Transferable room air conditioner of split type.**

The transferable room air conditioner of split type is essentially characterised in that the condenser is divided into two parts, namely a first part (4) located in the internal unit (1) and a second part (5) located in the external unit (2), so enabling the dimensions and weight of said external unit to be substantially reduced, thus facilitating its positioning and at the same time improving transferability of the entire assembly.

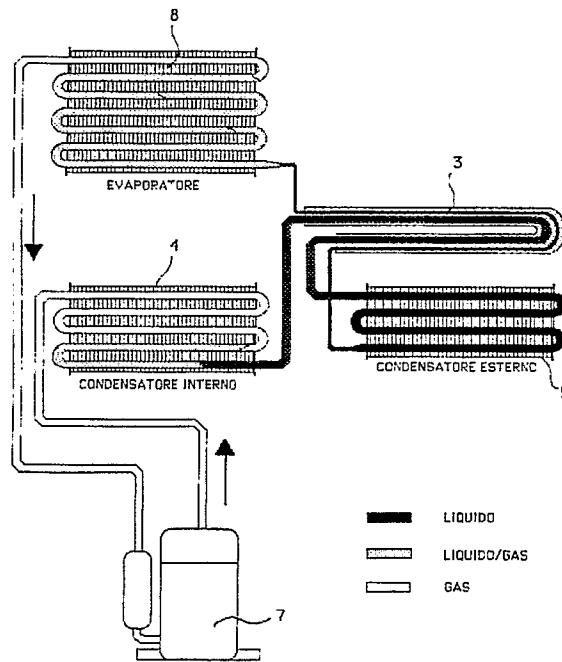

FIG.2

**EP 0 391 167 A2**

## TRANSFERABLE ROOM AIR CONDITIONER OF SPLIT TYPE

This invention relates to a transferable room air conditioner of split type.

This type of air conditioner is known to consist of a condenser unit located outside the room to be air conditioned and comprising an electrically operated fan, condenser and condensate disposal device, and a motor-driven evaporator unit located inside said room and comprising an electrically operated fan, compressor and evaporator, said two units being connected together by a flexible cord through which the pipes for the refrigeration medium, generally freon, the electrical cables for powering the external fan and the pipe for the condensed water led to the outside pass. The transferability of this type of air conditioner is in reality rather limited because of its size, its weight and the need to install the external condenser unit which, in conventional appliances, has to be positioned either suspended or resting at a certain distance from the wall to allow cooling air to be drawn in from behind.

An object of the invention is to provide a transferable room air conditioner of split type which is so configured as to reduce the dimensions and weight of the external unit to a minimum and thus obviate the drawbacks of conventional air conditioners of this type.

This and further objects of the invention will be apparent to the expert of the art on reading the following description.

The transferable room air conditioner of split type according to the invention comprises an internal unit containing an electrically operated fan, a compressor and an evaporator, and an external unit containing an electrically operated fan, said units being connected together by a flexible cord through which the pipes for the refrigeration medium and the electrical cables pass, and is essentially characterised in that the condenser is divided into two parts, of which a first part is located in the internal unit and the second part is located in the external unit, so enabling the dimensions and weight of said external unit to be substantially reduced, and at the same time improving transferability of the entire assembly.

A preferred embodiment is illustrated by way of non-limiting example on the drawing in which:

Figure 1 is a section through the air conditioner, shown overall;

Figure 2 shows the refrigeration circuit of the air conditioner of Figure 1.

With reference to said figures, the air conditioner consists conventionally of an internal unit indicated overall of 1, and an external unit indicated overall by 2, said two units being connected to-

gether by a flat flexible cord 3.

According to the invention the refrigeration medium is condensed in two separate condensers, namely a first condenser 4 located in the internal unit 1 and a second condenser located in the external unit 2, in contrast to conventional air conditioners of this type, which comprise a single condenser located in the external unit. As can be seen from Figure 1, the internal unit 1 houses an electrically operated fan 6 and a compressor 7, the fan drawing air from the room to be air conditioned and recycling it cooled and dehumidified to the same room after passing through an evaporator 8. A part of the air delivered by said fan is passed through the first condenser 4 to cool it and is then discharged to the outside through the small-diameter flexible tube 9. The condenser 4 is provided with means (not shown) for collecting and re-evaporating the water condensed by the evaporator 8.

As stated, the second condenser 5 is located in the external unit in front of an electrically operated fan 10 which draws air from in front of said unit 2 to cool said second condenser 5. As only a fraction of the condensation occurs in the external unit 2 and the condensate does not have to be re-evaporated, the size of this second condenser and the air quantity required for its cooling are considerably less than in the case of conventional arrangements, so enabling the dimensions and weight of the external unit to be drastically reduced (down to about 1/3 of conventional units), which can therefore be designed so as no longer to require air to be drawn in from its rear. The external unit thus becomes much more manageable and simple to position as it is now sufficient merely to stand it on the balcony or window sill, and allow the cord 3, now smaller than the conventional because it no longer carries the water tube, and the small flexible tube 9 for discharging the hot air which has cooled the inner condenser part 4 and also removes the condensate which has evaporated on it, to pass between the pulled-to casements. This air also represents the normal room air change.

### Claims

1. A transferable room air conditioner of split type comprising an internal unit (1) containing an electrically operated fan (6), a compressor (7) and an evaporator, and an external unit (2) containing an electrically operated fan (10), said units being connected together by a flexible cord (3) through which the pipes for the refrigeration medium and

the electrical cables pass, characterised in that the condenser is divided into two parts, of which a first part (4) is located in the internal unit (1) and the second part (5) is located in the external unit (2), said first (4) and second (5) part representing a separate first and second condenser respectively.

2. An air conditioner as claimed in claim 1, characterised in that said first condenser (4) is located along a part of the air path on the delivery side of said fan (6), downstream of said first condenser there being provided a tube (9) for discharging to the outside the air which has passed through said first condenser.

3. An air conditioner as claimed in claim 2, characterised in that said first condenser (4) comprises means for collecting and re-evaporating the condensate produced by said evaporator (8).

4. An air conditioner as claimed in claim 1, characterised in that said fan (10) is located in the external unit (2) on the rear of said second condenser (5) so that the air drawn in can be discharged through apertures advantageously provided in the top of said external unit.

5

10

15

20

25

30

35

40

45

50

55

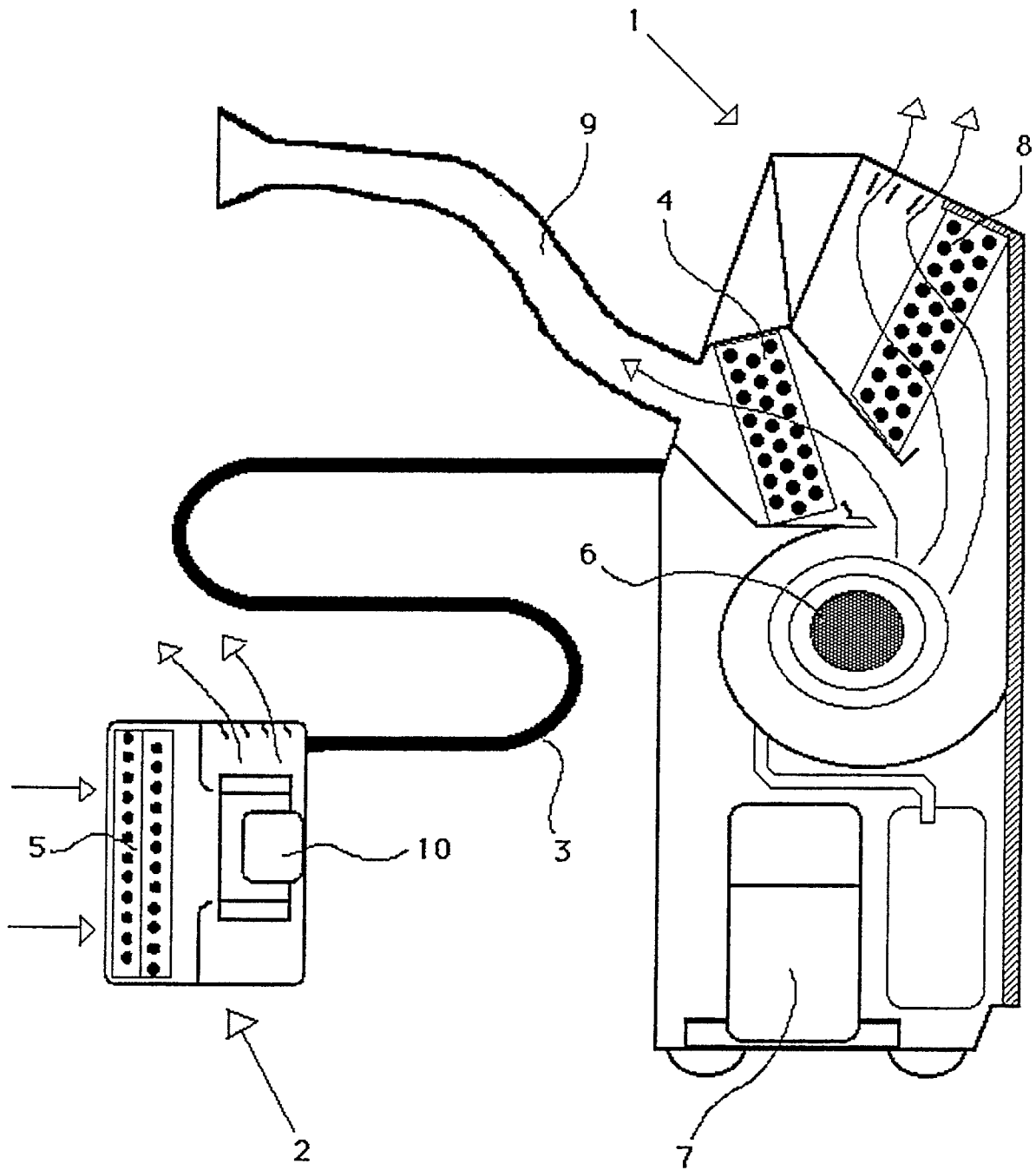

FIG. 1

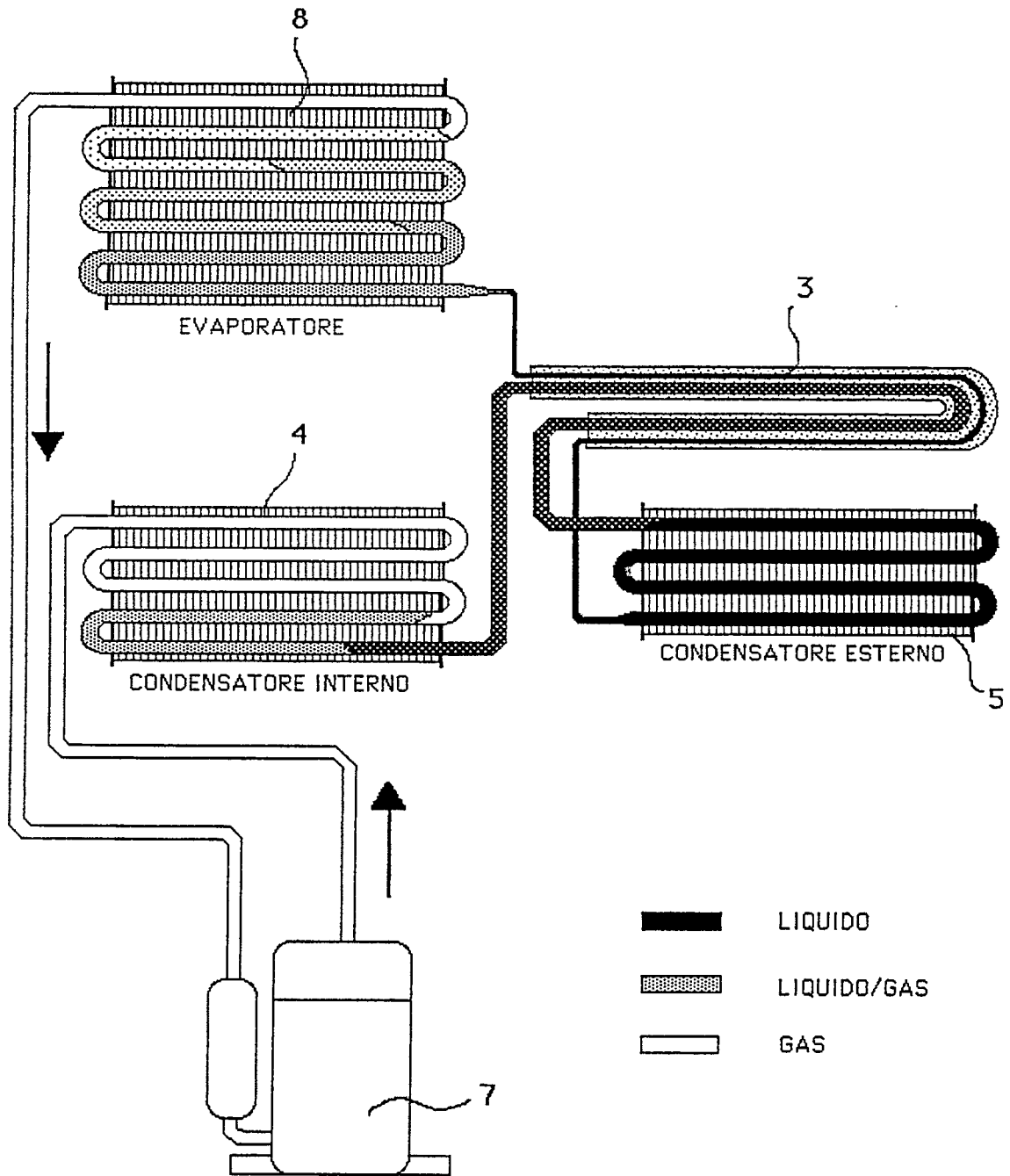

FIG.2